

Suraj Gupte

The Short Textbook of
PEDIATRICS

Incorporating National and International Recommendations
(MCI, IAP, NNF, WHO, UNICEF, IPA, ISTP, AAP, etc.)

ELEVENTH EDITION
(Fourth Decade of Publication)



JAYPEE

*Ripped by
Dr. Prodigions*

IN THEIR ESTEEMED OPINION.....

- Prof NS Tibrewala (Mumbai)** : *"... occupies pride of the place as a standard textbook... an indispensable companion..."*
- Prof PM Udani (Mumbai)** : *"An essential reading... a nice work."*
- Prof NR Bhandari (Bhopal)** : *"A great gift to the students, both undergraduates and postgraduates."*
- Prof DG Benakappa (Bangalore)** : *"Very comprehensive and up-to-date...highly recommended."*
- Prof N Sundravalli (Chennai)** : *"A work of special merit."*
- Prof AB Desai (Ahmedabad)** : *"...effectively worded and illustrated, and of great value."*
- Prof K Indira Bai (Annamalai)** : *"Comprehensive...extremely well written... ideal... strongly recommended."*
- Prof Meharban Singh (Noida)** : *"Very informative."*
- Prof GP Mathur (Kanpur)** : *"Very useful for undergraduates, postgraduates and practitioners."*
- Prof PK Misra (Lucknow)** : *"A very nice comprehensive textbook."*
- Prof K Kalra (Agra)** : *"Strongly recommended to undergraduates and postgraduates."*
- Prof Pinaki Banerjee (Kolkata)** : *"A very comprehensive book...ideal for students."*
- Prof SS Deshmukh (Nagpur)** : *"...fulfills a long awaited need... wonderful... very comprehensive."*
- Prof Rafiq Ahmed (Kolkata)** : *"A book of outstanding merit."*
- Prof KPS Sinha (Patna)** : *"A fine and appreciable work... clinical approach is commendable."*
- Prof SK Khetarpal (Amritsar)** : *"Concise, comprehensive, up-to-date and to the point..."*
- Prof PS Mathur (Gwalior)** : *"Warmly recommended."*
- Prof P Chaturvedi (Sewagram)** : *"Very helpful to students."*
- Prof Birendra Kumar (Darbhanga)** : *"A really very useful and precise volume for students."*
- Prof BK Garg (Meerut)** : *"Ideal for students."*
- Prof Shanta Karup (Kottayam)** : *"A very good work."*
- Prof Ananthakrishna (Chennai)** : *"Excellent...covers every aspect of pediatrics."*
- Prof NB Mathur (Sewagram)** : *"Highly useful...strongly recommended."*
- Prof AK Dikshit (Jamshedpur)** : *"The book fulfills a very long-standing need."*
- Prof AV Ramana (Warangal)** : *"Very useful for students as well as practitioners."*
- Prof SP Srivastava (Patna)** : *"Very up-to-date, comprehensive and appropriate for our students, both under- and postgraduates....."*
- Prof Neetu Raizada (Ludhiana)** : *"A highly recommended state-of-the-art textbook... an essential reading."*
- Prof B Sharda (Udaipur)** : *"Most comprehensive and state-of-the-art textbook..."*
- Prof Madhuri Kulkarni (Mumbai)** : *"... tailor-made to the needs of the students."*
- Prof A Parthasarthy (Chennai)** : *"A prototype of Nelson Textbook of Pediatrics.... modelled as per requirements in India..."*
- Prof AM Sur (Nagpur)** : *"... a boon for pediatric scholars in India in particular... warmly recommended."*
- Prof Utpal Kant Singh (Patna)** : *"...profusely illustrated, clinical-oriented, most upto date and ideal to meet the needs of students in India in particular."*
- Prof BS Prajapati (Ahmedabad)** : *"An essential reading for all students of pediatrics... carries valuable information including much-sought-after statistical data... useful for teachers too."*
- Prof VN Tripathi (Kanpur)** : *"A meritorious work...most suitable for undergraduates in particular and postgraduates in general."*
- Prof Javed Chowdhary (Srinagar)** : *"A textbook of extraordinary merit...An essential reading for the undergraduates as well as postgraduates..."*
- Prof Masood-ul-Hassan (Srinagar)** : *"Most upto date, well-illustrated, clinical-oriented, very comprehensive and student-friendly textbook... warmly recommended."*

- Prof Praveen C Sobti (Ludhiana)** : *“For over 3 decades, Dr Suraj Gupte’s textbook has been popular with undergraduates and postgraduates alike. The book contains all that the students need to know about common childhood illnesses in the developing world. It is a thoroughly readable book.”*
- Prof Vijay Sharma (Shimla)** : *“A highly recommended textbook of pediatrics..”*
- Prof DB Sharma (Jammu)** : *“Tailor-made for the needs of students in India...strongly recommended.”*
- Prof (Col) VS Puri (Jammu)** : *“An outstanding clinical-oriented textbook... most useful... warmly recommended.”*
- Prof Pankaj Abrol (Rohtak)** : *“A very comprehensive and up-to-date textbook of Pediatrics... a nice Indian response to Nelson’s Textbook of Pediatrics... can easily compete with best textbooks of pediatrics... A “must” for all students of pediatrics in India.”*
- Prof MMA Faridi (Delhi)** : *“There are many books around in the specialty but The Short Textbook of Pediatrics is unique...it makes the subject easy, interesting and understandable.”*
- Prof Rekha Harish (Jammu)** : *“This textbook of extraordinary merit eminently meets the requirements of students, especially the undergraduates, and is warmly recommended...”*
- Prof B Vishnu Bhat (Pondicherry)** : *“Well-written book covering all information needed by undergraduates and postgraduates in pediatrics. Good reference book for practising pediatricians as well...”*
- Prof Ajay Gaur (Gwalior)** : *“...a genuinely good book for the undergraduate and postgraduate students with the expertise of eminent academicians... The contents are well presented in a uniform style and in keeping with the standard protocols and guidelines.... .”*
- Prof Ghanshyam Saini (Jammu)** : *“...an extraordinary work... a very useful tool for the undergraduates, postgraduates and academicians.”*
- Prof RK Gupta (Jammu)** : *“An excellent textbook, full of latest updates... unique in itself, providing concise but comprehensive information invaluable in pediatric education for the undergraduates and postgraduates.”*
- Prof E Chen (Malaysia)** : *“A complete textbook on tropical pediatrics...a “must possession” by each and every student of pediatrics in the region.”*
- Prof Shaukat Siddiqui (Pakistan)** : *“Most valuable for the pediatric UGs, PGs, teaching faculty and practising pediatricians as also for the GPs treating infants, children and adolescents in the subcontinent...”*
- Prof RN Koirala (Nepal)** : *“An exceptionally useful textbook of pediatrics, eminently meeting the needs of our students and their teachers...most suitable for our settings.”*
- Prof JE Jaywardne (Sri Lanka)** : *“A warmly recommended pediatric textbook, focusing exactly on what is needed by our medical students, emerging pediatricians and teachers...”*
- Prof AQ Bhashani (Bangladesh)** : *“The textboook is a spotlight on everything that we need to teach our students of pediatrics in Bangladesh and neighboring countries...”*

**THE SHORT
TEXTBOOK OF
PEDIATRICS**

THE SHORT TEXTBOOK OF PEDIATRICS

11th
Edition
(Fourth Decade of
Publication)

Incorporating National and International Recommendations (MCI, IAP, NNF, WHO, UNICEF, IPA, ISTP, AAP, etc)

Edited by

Suraj Gupte MD, FIAP

Professor and Head

Postgraduate Department of Pediatrics

Narayana Medical College/Narayana General and Superspeciality Hospitals

Nellore 524 002, AP, South India

E-mail: surajgupte@rediffmail.com

recentadvances@yahoo.co.uk

Honorary Director: Pediatric Education Network

Editor: Recent Advances in Pediatrics (Series), Textbooks of Pediatric Emergencies, Neonatal Emergencies and Pediatric Nutrition, Pediatric Gastroenterology, Hepatology and Nutrition, Towards MRCPCH Part II (Theory Examination), Pediatric Yearbook (Series), Newer Horizons in Tropical Pediatrics, etc.

Author: Differential Diagnosis in Pediatrics, Instructive Case Studies in Pediatrics, Pediatric Drug Directory, Infant Feeding, Speaking of Child Care, The Baby Book: The Parents' Guide from Birth to Infancy

Co-editor: Asian Journal of Maternity and Child Health (Manila, Philippines)

Section and Guest Editor: Pediatric Today (New Delhi)

Editorial Advisor: Asian Journal of Pediatric Practice (New Delhi)

Editorial Advisory Board Member/Reviewer: Indian Journal of Pediatrics (New Delhi), Indian Pediatrics (New Delhi), Synopsis (Detroit, USA), Indian Journal of Pediatric Gastroenterology, Hepatology and Nutrition (Jaipur), Maternal and Child Nutrition (Preston, UK), Journal of Infectious Diseases (Turkey)

Examiner: National Board of Examinations (NBE) for DNB, New Delhi; All India Institute of Medical Sciences (AIIMS), New Delhi; Postgraduate Institute of Medical Education and Research (PGIMER), Chandigarh; Sher-i-Kashmir Institute of Medical Sciences (SKIMS), Srinagar; Indira Gandhi Open University (IGNOU), New Delhi

Pediatric Faculty Selection Expert: All India Institute of Medical Sciences (AIIMS), Punjab Public Service Commission, Jammu and Kashmir Public Service Commission, Union Public Service Commission



JAYPEE BROTHERS MEDICAL PUBLISHERS (P) LTD

New Delhi • Ahmedabad • Bengaluru • Chennai • Hyderabad • Kochi • Kolkata • Lucknow • Mumbai • Nagpur
• St. Louis (USA)

Published by

Jitendar P Vij

Jaypee Brothers Medical Publishers (P) Ltd

Corporate Office

4838/24 Ansari Road, Daryaganj, **New Delhi** - 110002, India, Phone: +91-11-43574357

Registered Office

B-3 EMCA House, 23/23B Ansari Road, Daryaganj, **New Delhi** - 110 002, India

Phones: +91-11-23272143, +91-11-23272703, +91-11-23282021

+91-11-23245672, Rel: +91-11-32558559, Fax: +91-11-23276490, +91-11-23245683

e-mail: jaypee@jaypeebrothers.com, Visit our website: www.jaypeebrothers.com

Branches

- ❑ 2/B, Akruiti Society, Jodhpur Gam Road Satellite
Ahmedabad 380 015, Phones: +91-79-26926233, Rel: +91-79-32988717
Fax: +91-79-26927094, e-mail: ahmedabad@jaypeebrothers.com
- ❑ 202 Batavia Chambers, 8 Kumara Krupa Road, Kumara Park East
Bengaluru 560 001, Phones: +91-80-22285971, +91-80-22382956
91-80-22372664, Rel: +91-80-32714073, Fax: +91-80-22281761
e-mail: bangalore@jaypeebrothers.com
- ❑ 282 Illrd Floor, Khaleel Shirazi Estate, Fountain Plaza, Pantheon Road
Chennai 600 008, Phones: +91-44-28193265, +91-44-28194897
Rel: +91-44-32972089, Fax: +91-44-28193231,
e-mail: chennai@jaypeebrothers.com
- ❑ 4-2-1067/1-3, 1st Floor, Balaji Building, Ramkote Cross Road,
Hyderabad 500 095, Phones: +91-40-66610020, +91-40-24758498
Rel: +91-40-32940929 Fax: +91-40-24758499
e-mail: hyderabad@jaypeebrothers.com
- ❑ No. 41/3098, B & B1, Kuruvi Building, St. Vincent Road
Kochi 682 018, Kerala, Phones: +91-484-4036109, +91-484-2395739
+91-484-2395740 e-mail: kochi@jaypeebrothers.com
- ❑ 1-A Indian Mirror Street, Wellington Square
Kolkata 700 013, Phones: +91-33-22651926, +91-33-22276404
+91-33-22276415, Rel: +91-33-32901926, Fax: +91-33-22656075
e-mail: kolkata@jaypeebrothers.com
- ❑ Lekhranj Market III, B-2, Sector-4, Faizabad Road, Indira Nagar
Lucknow 226 016 Phones: +91-522-3040553, +91-522-3040554
e-mail: lucknow@jaypeebrothers.com
- ❑ 106 Amit Industrial Estate, 61 Dr SS Rao Road, Near MGM Hospital, Parel
Mumbai 400 012, Phones: +91-22-24124863, +91-22-24104532,
Rel: +91-22-32926896, Fax: +91-22-24160828
e-mail: mumbai@jaypeebrothers.com
- ❑ "KAMALPUSHPA" 38, Reshimbag, Opp. Mohota Science College, Umred Road
Nagpur 440 009 (MS), Phone: Rel: +91-712-3245220, Fax: +91-712-2704275
e-mail: nagpur@jaypeebrothers.com

USA Office

1745, Pheasant Run Drive, Maryland Heights (Missouri), MO 63043, **USA**, Ph: 001-636-6279734

e-mail: jaypee@jaypeebrothers.com, anjulav@jaypeebrothers.com

The Short Textbook of Pediatrics, 11th Edition

© 2009, Suraj Gupte, Editor

All rights reserved. No part of this publication should be reproduced, stored in a retrieval system, or transmitted in any form or by any means: electronic, mechanical, photocopying, recording, or otherwise, without the prior written permission of the editor and the publisher.

This book has been published in good faith that the material provided by the contributors is original. Every effort is made to ensure accuracy of material, but the publisher, printer and editor will not be held responsible for any inadvertent error(s). In case of any dispute, all legal matters to be settled under Delhi jurisdiction only.

First Edition : 1977

Second Edition : 1979

Third Edition : 1982

Fourth Edition : 1983

Fifth Edition : 1985

Sixth Edition : 1989

Seventh Edition : 1995

Eighth Edition : 1998

Ninth (Millennium) Edition : 2001

Tenth (Silver Jubilee) Edition: 2004

Eleventh (Fourth Decade of Publication) Edition: **2009**

ISBN 978-81-8448-469-4

Typeset at JPBMP typesetting unit

Printed at Gopsons Papers Ltd., A-14, Sector 60, Noida

*To
The fond memory of my parents
whose inspiration, motivation, blessings
and moral support continue to contribute a great
deal to my academic endeavors
and
everybody striving to contribute to child health
and welfare for a brighter future
globally.*

Contributors

RA Anderson

Professor
Department of Pediatric Gastroenterology, Hepatology and
Nutrition, Institute of Child and Adolescent Health
London, UK
Ch 24: Pediatric Gastroenterology
Ch 25: Pediatric Hepatology

Lalita Bahl

Ex-Professor and Head
Department of Pediatrics
Indira Gandhi Medical College
Shimla, India
Ch 16: Fluids, Electrolytes and Acid-base Balance and Its Disturbances
Ch 46: Pediatric Drug Dosages

Surya Bhan

Professor
Department of Orthopedics
All India Institute of Medical Sciences
New Delhi, India
Ch 41: Pediatric Orthopedics

B Vishnu Bhat

Director-Professor
Department of Pediatrics
Jawaharlal Institute of Postgraduate Medical Education and
Research, Pondicherry, India
Ch 36: Pediatric Neuromuscular Disorders

Jagdish Chandra

Professor
Kalawati Saran Children's Hospital
Lady Hardinge Medical College
New Delhi, India
Ch 27: Pediatric Hematology

Mridula Chatterjee

Professor and Head
Pediatric Department
North Bengal Medical College
Kadamtala, Siliguri, West Bengal, India
Ch 8: Pediatric Biostatistics and Informatics

Aniece Chowdhary

Professor and Head
Department of ENT and Head and Neck Surgery
Government Medical College/SMGS Hospital
Jammu, Jammu and Kashmir, India
Ch 38: Pediatric Ear, Nose and Throat (ENT) Problems

Bhavna B Chowdhary

Lecturer
School of Medical Studies
Edinburgh, UK
Ch 23: Pediatric Neurology
Ch 44: Pediatric Laboratory Procedures

Javed Chowdhary

Professor and Head
Department of Pediatrics
Government Medical College
Srinagar, Jammu and Kashmir, India
Ch 17: Neonatology

S Frank

Professor and Head
Department of Immunology and Genetics
Institute of Child and Adolescent Health
London, UK
Ch 29: Pediatric Immunology
Ch 35: Genetics in Pediatric Practice

EM Gomez

Associate Clinical Professor
Department of Infant and Child Nutrition
Institute of Child and Adolescent Health
London, UK
Ch 3: Growth and Development
Ch 12: Infant Feeding
Ch 13: Protein-energy Malnutrition

AM Graham

Clinical Professor
Center for Hemato-oncology
Boston, Massachusetts, USA
Ch 28: Pediatric Oncology

x The Short Textbook of Pediatrics

Devendra Gupta

Professor and Head
Department of Pediatric Surgery
All India Institute of Medical Sciences (AIIMS)
New Delhi, India
Ch 40: Pediatric Surgery

Suraj Gupte

Professor and Head
Postgraduate Department of Pediatrics
Narayana Medical College/Narayana General and
Superspeciality
Hospitals, Nellore, South India
Chapters: All chapters as senior or coauthor

BP Karunakara

Assistant Professor
Department of Pediatrics
MS Ramaiah Medical College/Teaching Hospital
Bangalore, Karnataka, India
Ch 22: Pediatric Cardiology

RK Kaushal

Professor and Head
Department of Pediatrics
Indira Gandhi Medical College
Shimla
Ch 32: Pediatric Accidental Poisoning
Ch 33: Pediatric Envenomations

AW Koff

Professor, Department of Pediatric Endocrinology
Institute of Child and Adolescent Health
London, UK
Ch 34: Pediatric Endocrinology

ML Kulkarni

Professor and Head
Department of Pediatrics
JJM Medical College
Davangere, Karnataka, India
Ch 29: Pediatric Immunology

PP Maiya

Professor and Head
Department of Pediatrics
MS Ramaiah Medical College/Teaching Hospital
Bangalore, Karnataka, India
Ch 22: Pediatric Cardiology

NK Nagpal

Assistant Professor
Department of Dental and Orofacial Surgery
Institute of Child and Adolescent Health
London, UK
Ch 39: Pediatric Dental Problems

NE Parsons

Clinical Professor
Department of Dermatology
Institute of Child and Adolescent Health
London, UK
Ch 31: Pediatric Dermatology

AK Sahni

Assistant Professor
Department of Adolescent Medicine
Institute of Child and Adolescent Health
London, UK
Ch 7: Adolescence

DM Sharma

Assistant Professor
Department of Rheumatology
Institute of Child and Adolescent Health
London, UK
Ch 30: Pediatric Collagenosis

RM Shore

Assistant Professor
Department of Nephrology
Institute of Child and Adolescent Health
London, UK
Ch 26: Pediatric Nephrology

Daljit Singh

Principal
Dayanand Medical College
Ludhiana, Punjab, India
Ch 21: Pediatric Pulmonology

Karnail Singh

Professor and Head
Department of Pediatrics
Government Medical College
Amritsar, Punjab, India
Ch 19: Pediatric Bacterial Infections

Ksh Chourjit Singh

Ex-Professor and Head
Department of Pediatrics
North-East Regional Medical College
Imphal, Manipur, India
Ch 18: Pediatric Viral Infections

Tejinder Singh

Professor and Head
Department of Pediatrics
Christian Medical College
Ludhiana, Punjab, India
Ch 6: Child Psychiatry and Behavioral Problems
Ch 9: Community Pediatrics

Utpal Kant Singh

Professor and Head
Department of Pediatrics
Nalanda Medical College
Patna, Bihar
India
Ch 20: Pediatric Parasitosis

Rita Smith

Director-Professor of Pediatrics
Institute of Child and Adolescent Health
London, UK
Ch 1: Pediatric History-taking and Clinical Examination

Praveen C Sobti

Professor and Head of the Unit
Department of Pediatrics
Dayanand Medical College
Ludhiana, Punjab
India
Ch 27: Pediatric Hematology

Shashi Vani

Professor and Head
Department of Pediatrics
PS Medical College
Karamsad, Anand, Gujarat, India
Ch 11: Pediatric Nutritional Requirements
Ch 17: Neonatology

Vasudev Vatwani (Brig)

Professor and Head
Department of Pediatrics
Dr DY Patil Medical College
Pimpri, Pune, Maharashtra, India
Ch 43: Pediatric Practical Procedures

Vijay Wali

Ex-Professor and Head
Department of Ophthalmology
Government Medical College
Jammu, Jammu and Kashmir, India
Ch 37: Pediatric Ophthalmology

Foreword

It gives me great pleasure to write this Foreword to the 11th edition of *The Short Textbook of Pediatrics* edited by Dr Suraj Gupte. He is a recognized pediatric academician, researcher, innovator and educationist of our country and is keenly interested in writing—not only on medical subjects, but also diverse areas, including fiction. He was the recipient of the 1976-Wodehouse Award for his *The Last Summer*. He was the first Indian and the youngest ever to receive this international award.

The Short Textbook of Pediatrics, the first Indian textbook of pediatrics, is written in a simple and fluent language. It gives useful information on the problems of child health in our country and, in brief, a clear concept of the subject. The chapters on growth and development, infant feeding, micronutrient/mineral deficiencies, infections and infestations, immunization, diarrheas, neonatology, immunology and many others are particularly very relevant to our country. The students and teachers of medicine will do well to go through the same carefully. Comprehensiveness is an outstanding feature of this book.

In India, in spite of the country's advances in the field of pediatrics, there is a dearth of well-written textbooks on pediatrics for the use of undergraduates. In recent years, child health has assumed great significance in our country. Today, its importance is being realized more and more by the medical educators, the students and the general public. Of late, the Medical Council of India (MCI) has made "pediatrics" a major and an examination discipline in undergraduate curriculum. It is in the fitness of things that textbooks satisfying the requirements of our country are brought out on the subject. This book, by virtue of its simplicity, flow of language, excellent material and useful statistical data, fulfills this lacuna eminently. At the same time, it is fully in accordance with the syllabus/curriculum recommended by the Indian Academy of Pediatrics (IAP) and finally approved and adopted by the Medical Council of India (MCI).

I am happy that the textbook has been exceedingly well received by the medical professionals, especially the undergraduate medical community of India and other developing countries, ever since it was first published in 1977. Today, it occupies "pride of the place" as a standard textbook in India and several other countries of South-East Asia.

The strategic changes affected in the 10th edition, rendering the book as multiauthor, to meet the requirements of the Medical Council of India (MCI) that had given pediatrics the status of an independent subject at the university level, further enhanced its popularity, acceptability and utility.

I am very confident that the 11th edition of *The Short Textbook of Pediatrics* ("STP" as it is popularly known as) shall be yet more successful and record its significant contribution in improving the standard of pediatric education and child health care in the Indian subcontinent in particular and the developing world in general.

Rungta House
68A, Nepean Sea Road
Mumbai-400 006

Prof NS Tibrewala
MD DCH D PED FCCP (USA)
President, XV International Congress of Pediatrics
Hon. Pediatrician, Bombay Hospital, Mumbai
Past President, Indian Academy of Pediatrics
Chairman, Board of Studies in Medicine and Allied
Subjects, University of Bombay, 1970-75
Ex-Director/Professor, Dept. of Pediatrics, TN Medical
College and BYL Nair Hospital, Mumbai
Maharashtra (India)

Preface to the Eleventh Edition

The 11th edition of *The Short Textbook of Pediatrics* appears at a time when pediatrics has well established its status as an independent subject in the undergraduate curriculum with a separate examination at university level in India. Since the last edition eminently succeeded in meeting the needs of the undergraduate students, here we have made further strides to attain the enhanced excellence not only for them but also for the benefit of postgraduates, residents, practitioners and teachers. The goal is to provide a blend of time-honored concepts along with new advances with special emphasis on the needs in the Indian subcontinent.

Each and every chapter stands updated with extensive revisions and/or rewriting, reorganization and additional material, including new chapters and new illustrations in keeping with the changing needs. Naturally, the Index is further expanded. As a result, the new edition is yet more reader-friendly, state-of-the-art and practical-oriented. Yet, the hallmarks of the earlier editions, namely brevity with comprehensiveness, simple and straight-forward style and easy-to-understand expression have been retained and, in fact, further strengthened.

Admittedly, the unique and enhanced value of the 11th edition is very much on account of the expertise, hard work and command in the respective fields of the distinguished contributors. My hats off to them!

Over and above the learned contributors, a multitude of colleagues, friends and readers, in India and abroad, made worthy suggestions for enhancing the utility of the book. Informed assistance from the faculty of the Postgraduate Department of Pediatrics, Narayana Medical College and Hospitals, especially, Dr CM Kumar, is particularly acknowledged. The Chairman, Dr P Narayana, the Adviser, Dr CL Venkata Rao, the Medical Superintendent, Dr JN Rao and Vice-Principal and Coordinator, Dr S Vijay Kumar were gracious enough to provide moral support and motivation in completing this project.

My wife, Shamma, graciously assisted me so much in taking the project to its logical conclusion. So did my daughter, Dr Novy, and son, Er Manu, in spite of their preoccupations.

Prof (Dr) NS Tibrewala, now a legend in the pediatric circles, has once again been gracious enough to write *Foreword* to this edition.

Last but not the least, I wish to thank M/s Jaypee Brothers Medical Publishers (P) Ltd and their dedicated staff for the skillfull production qualities of the 11th edition.

SURAJ GUPTE MD, FIAP

Professor and Head

Postgraduate Department of Pediatrics
Narayana Medical College/Narayana General and
Superspeciality Hospitals, Nellore, South India

Preface to the First Edition

“Whyn’t a handy pediatric book for our students?”-Requests like this virtually flooded me as I was in the thick of editing the *Newer Horizons in Tropical Pediatrics* last year. Today, I am glad to offer that much-demanded work in the form of *The Short Textbook of Pediatrics*.

The Short Textbook of Pediatrics is aimed at providing a concise, simple and profusely-illustrated digest of the contemporary pediatrics, relevant to the developing world. Common tropical problems, such as nutritional deficiencies, diarrheas, tuberculosis and other frequent infections and parasitic infections and immunization, have received special attention. Certain areas that are important to us but have been ignored by the western authors are, in particular, dealt with. Indian childhood cirrhosis, infantile tremor syndrome, primary bladder stone disease, BCG as a diagnostic tool and tuberculous encephalopathy figure in this list. The accent is on priorities, clinical aspects and latest information rather than on rare conditions and outdated theoretical discussion.

The book is addressed primarily to the medical students, new entrants to the specialty of pediatrics and practising physicians who deal with infants and children as well. Some material especially the statistical data and up to date reference—some as latest as of 1977—are likely to be of value to the seniors either. How far have I succeeded in my endeavors? In this behalf, I would love to have your assessment. That shall help me to make up the deficiencies and introduce the “necessary changes for the better” in the future edition.

The publisher, Mr Jitendar P Vij of M/s Jaypee Brothers Medical Publishers (P) Ltd., and the Managing Editor, Rajendra Gupte’s contributions have been vital to the appearance of this manual.

Much of the material included in *The Short Textbook of Pediatrics* is based on articles in the recent WHO/UNICEF publications, *Indian Journal of Pediatrics*, *Indian Pediatrics*, *Indian Practitioner* and other Indian and foreign periodicals and books. I have punctuated the accounts with our own observations at the prestigious Postgraduate Institute of Medical Education and Research, Chandigarh, HP Medical College, Shimla, and Govt. Medical College, Jammu. The superb teaching of Prof BNS Walia, Dr (Mrs) Saroj Mehta, Dr ON Bhakoo, Dr SK Mehta, Dr (Mrs) A Perakash and Col ML Magotra has proved to be a source of guidance and stimulation in preparing this book.

Hats off to many of my past and present colleagues, friends and well-wishers for lots of good-will, ideas and cooperation; Dr JC Lall, Dr RK Chaudhary, Dr (Miss) Kalpana Kohli, Dr (Miss) Rita Malhotra, Dr Vinod Seth, Mrs Neelam Virmani, Mr Ayudhia Kaul and Mr GS Malhotra deserve a special mention. Dr Satish Gupte, Dr (Miss) Prem Gupte and Miss Shamma Bakshi extended enthusiastic assistance in preparing the manuscript, proof-reading and indexing.

Major (Mrs) BK Sohi and Lt. Col AS Sohi have been exceedingly courteous in making available a number of excellent clinical photographs. I must also acknowledge the help received from Prof H Shirkey, Dr Roy Brown, Prof Ashfaq Ahmad and Dr VK Dogra.

Prof NS Tibrewala has been kind enough to write the *Foreword* in spite of his preoccupations, especially as President of the forthcoming *15th International Congress of Pediatrics*. He has indeed done me an honor.

Principal NS Pathania, Prof SS Manchanda, Prof PM Udani, Prof RS Dayal and Prof VB Raju figure among our eminent medical men who graciously blessed this project. I should record my appreciation of the fond interest evinced in this manual by Mr KA Padmanabhan, Mr Suraj Saraf and Dr K Chaudhry—all leading journalists.

Finally, I greatly value the favors extended by my folks through various stages of this publication. My kid sister, Veenu and brothers, Subhash and Raji helped me in many a way. They would cheer me up as and when I found the going tough.

To all of them, plus all those who contributed but are not identified here, I am highly grateful.

“Gupte House”
60 Lower Gumat
Jammu

SURAJ GUPTE MD

Acknowledgments

Special acknowledgements are made to

- Indian Academy of Pediatrics
- National Neonatology Forum
- World Health Organization (WHO)
- UNICEF
- American Academy of Pediatrics
- International Pediatric Association
- International Society of Tropical Pediatrics
for incorporating their recommendations in this volume, and
- Recent Advances in Pediatrics by Prof (Dr) Suraj Gupte
- Annales Nestle
- The Short Textbook of Medical Microbiology by Prof (Dr) Satish Gupte
- The Clinical Recognition of Congenital Heart Disease by Prof (Dr) JK Perloff
- Prof (Dr) K Indira Bai
- Maj (Dr) BK Sohi
- Prof (Dr) GP Mathur
- Dr Novy Gupte
- Cipla Ltd

for providing certain figures.

Every attempt has been made to acknowledge the sources of information at concerned points, in bibliography and/or here. Omission, if any, is unintentional and is regretted.

Contents

PART ONE: CORE PEDIATRICS

1. Pediatric History-taking and Clinical Examination 3	5. Developmental Disorders 46
<i>Suraj Gupte, Rita Smith</i>	<i>Suraj Gupte</i>
The Art of History Taking 3	Developmental Delay 46
The Art of Physical Examination 6	Learning Disabilities (Dyslexia) 46
A Sample (Model) Pediatric Case Sheet 14	Attention-deficit Hyperactivity Disorder (ADHD) 47
2. Pediatrics in the Developing World 15	Autistic Spectrum Disorders 48
<i>Suraj Gupte</i>	Enuresis (Bedwetting) 49
Contemporary Pediatrics 15	Cerebral Palsy 51
Changing Pediatric Scenario 15	Behavioral Problems 51
Tropical Pediatrics 16	6. Child Psychiatry and Behavioral Problems 52
Rights of the Child 17	<i>Suraj Gupte, Tejinder Singh</i>
Contemporary Disease Pattern and Changing Concerns 18	Psychiatric Disorders: An Overview 52
Mortality Scenario and Delivery of Child Health Care 20	Behavioral Problems 53
Pediatric Education 23	Pica (Geophagia) 54
3. Growth and Development 25	Anorexia Nervosa and Bulimia 55
<i>Suraj Gupte, EM Gomez</i>	Enuresis 55
Definitions 25	Sleep Walking (Somnambulism) 55
Growth Studies 25	Breath-holding Spells 55
Various Factors Influencing Growth and Development 25	Thumb-sucking and Nail Biting 56
Various Periods of Growth 27	Teeth Grinding (Bruxism) 56
Laws (Principles) of Growth 27	Stuttering 56
Important Criteria/Indices for Assessment of Growth 28	Tics (Habit Spasm) 56
Linear Catchup Growth 36	School Phobia 57
Growth (Reference) Standards 36	Drug Abuse 57
Puberty (Adolescence) 37	Periodic Syndrome 57
Development 37	Child Abuse and Neglect 58
Normal Developmental Milestones 37	Principles of Counseling 58
Assessment of Development 37	7. Adolescence 60
Approaches to Developmental Screening 39	<i>Suraj Gupte, AK Sahni</i>
4. Growth Disorders 40	Special Features of Three Stages of Adolescence 60
<i>Suraj Gupte</i>	Puberty Changes (Changes during Adolescence) . 60
Failure to Thrive 40	Factors Influencing Adolescent Health and Development 62
The Child with Short Stature 42	Adolescent Psychology 63
	Adolescent Sexuality 63
	Adolescent Nutrition 64
	Special Health, Medical and Psychosocial Problems 64
	Promotion of Adolescent Health 69

8. Pediatric Biostatistics and Informatics	71	<i>H. influenza</i> Vaccination	105
<i>Mridula Chatterjee, Suraj Gupte</i>		Hepatitis B Vaccine	105
Biostatistics	71	Hepatitis A Vaccine	106
Medical Informatics, Telemedicine, Cybermedicine and Internet	73	Varicella Virus (Chickenpox) Vaccine	106
9. Community Pediatrics	78	Combined Vaccines	106
<i>Tejinder Singh, Suraj Gupte</i>		Polyvalent Pneumococcal Vaccine	107
Health	78	Influenza Vaccine	107
Community Pediatrics	78	Meningococcal Vaccine	107
Preventive Pediatrics	79	Japanese Encephalitis Vaccine	108
Social Pediatrics	79	Vaccination against Rabies	108
Family Health	79	11. Pediatric Nutritional Requirements	109
Under-Fives Clinics	80	<i>Suraj Gupte, Shashi Vani</i>	
Baby-Friendly Hospital Initiative (BFHI)	80	Water	109
School Health Service	81	Energy	109
Juvenile Delinquency	82	Proteins	110
Maternal and Child Health (MCH)	82	Carbohydrates	110
Integrated Child Development Services (ICDS) Scheme	84	Fats	111
Child Labor	86	Vitamins	111
Street Children	88	Minerals and Trace Elements	111
The Handicapped Child	89	Antioxidants	112
The Girl Child	90	Indian Scenario	113
Prevention of Accidents	92	12. Infant Feeding	115
Child Abuse and Neglect	93	<i>Suraj Gupte, EM Gomez</i>	
Integrated Management of Neonatal and Childhood Illness (IMNC) Strategy	93	Anatomical Aspects of Lactation	115
India's National Health Programs	94	Physiology of Lactation	115
Acute Flaccid Paralysis (AFP) Surveillance	95	Breastfeeding	116
Television and the Child	95	Common Breastfeeding Problems	118
Disposal of Hospital Waste	96	Lactation Failure	119
10. Immunization	97	Complementary Feeding	120
<i>Suraj Gupte</i>		Artificial (Formula) Feeding	122
Basics of Immunization	97	Feeding the Low Birthweight (LBW) Infant	122
Categories of Vaccines	97	Non-nutritive Suckling	125
Cold Chain	98	Common Feeding Problems	126
Some Additional Immunization-related Matters	98	13. Protein-energy Malnutrition	129
• Vaccine Vial Monitoring	98	<i>Suraj Gupte, EM Gomez</i>	
• Route of Administration	98	Ecology of Malnutrition	129
• Safe Injection Practices	98	Assessment of Nutritional Status	130
Recommended Immunization Schedule	98	Protein-energy Malnutrition (PEM): A spectrum	133
BCG Vaccination	98	Evolution of PEM	134
Polio Vaccination	100	PEM and Disturbances of Metabolism	135
DPT Vaccination	102	PEM and Infection	136
Enhanced Inactivated Polio Vaccine (Salk Vaccine)	102	PEM and Family Planning	137
Typhoid Vaccination	103	PEM and Endocrinal Status	137
Cholera Vaccination	103	PEM and Diarrhea	138
Measles Vaccination	103	PEM and Cardiac Function	139
Mumps Vaccination	104	PEM and Renal Function	139
Rubella Vaccination	104	PEM and Drug Disposition	139
		Classification of PEM	139
		Special Features of Clinical Syndromes	140
		Marasmic Kwashiorkor	145
		Prekwashiorkor	145

Nutritional Dwarfism (Stunting)	145	Nomenclature/Definitions Related to Perinatal/ Neonatal Period	185
Complications of PEM	146	High-risk Pregnancy	186
Management of PEM	146	Neonatal and Perinatal Mortality in India	186
Phenomena Encountered during Nutritional Rehabilitation	149	Birth Trauma	188
Prognosis in PEM	150	Congenital and Other Defects	188
Long-term Sequela of PEM	150	Neonatal Resuscitation	188
Prevention of Malnutrition	150	Apgar Score	195
National Nutrition Programs	151	The Fullterm Newborn	196
National Nutrition Policy	153	Primitive Neonatal Reflexes	199
14. Vitamin Deficiencies	155	Some Minor Problems of the Newborn	202
<i>Suraj Gupte</i>		The Preterm Infant	204
Vitamin A Deficiency	155	Low Birth Weight (LBW) Infants	206
Thiamine Deficiency	158	Stages of the Newborn Care	208
Riboflavin Deficiency	159	Basic Principles of Essential Newborn Care	209
Nicotinic Acid Deficiency	160	The 3-Tier System of Neonatal Care	209
Pyridoxine Deficiency	160	Determination of Gestational Age	209
Vitamin B ₁₂ Deficiency	161	Danger Signs	210
Folic Acid Deficiency	161	Neonatal Hypothermia	210
Vitamin C Deficiency	161	Kangaroo Mother Care (KMC)	211
Vitamin D Deficiency	163	Breastfeeding	212
Refractive Rickets	166	Incubator Care	212
Vitamin E Deficiency	167	Open Care System	212
Vitamin K Deficiency	168	Hypoxic-ischemic Encephalopathy	213
15. Micronutrients/Minerals	170	Respiratory Distress Syndrome	215
<i>Suraj Gupte</i>		Hyaline Membrane Disease (HMD)	215
Iron Deficiency Disorders	170	Meconium Aspiration Syndrome (MAS)	217
Zinc Deficiency	170	Persistent Pulmonary Hypertension of the Newborn (PPHN)	218
Copper Deficiency	171	Transient Tachypnea of the Newborn (TTN)	218
Cobalt and Selenium	171	Neonatal Shock	218
Chromium, Manganese, Fluorine, Molybdenum, Nickel, Vanadium, Silicon and Arsenic	172	Recurrent Neonatal Apnea (Apneic Spells)	219
Iodine Deficiency (Endemic Goiter)	172	Infections in the Newborn	220
Calcium Deficiency	172	Stridor	220
Magnesium Deficiency	173	Congenital Syphilis	220
Immunonutrition	173	Congenital Toxoplasmosis	221
Sodium and Potassium Deficiency	173	Congenital Rubella	221
16. Fluids, Electrolytes and Acid-base Balance and its Disturbances	174	Cytomegalovirus Disease	222
<i>Lalita Bahl, Suraj Gupte</i>		Herpes Simplex	222
Physiologic Considerations	174	Perinatal AIDS	223
Disorders of Fluid and Electrolyte Balance	177	Septic Umbilicus (Omphalitis)	223
Disturbances of Acid-base Balance	179	Septicemia	223
Principles of Fluid and Electrolyte Therapy	181	Conjunctivitis	225
Fluid Therapy in Special Situations	181	Pyoderma	226
		Oral Thrush (Moniliasis, Candidiasis)	226
		Noma Neonatorum	226
		Neonatal Malaria	226
		Tetanus Neonatorum	227
		Hemorrhagic Disease of the Newborn	228
		Neonatal Jaundice	228
		Neonatal cholestasis Syndrome	235
		Hemolytic Disease of the Newborn	236
PART TWO: NEONATOLOGY			
17. Neonatology	185		
<i>Shashi Vani, Javed Chowdhary, Suraj Gupte</i>			
Importance of the Neonatal Care	185		

Kernicterus	237
Neonatal Seizures	238
Neonatal Hypoglycemia	239
Neonatal Hypocalcemia (Neonatal Tetany)	240
Neonatal Hypomagnesemia	240
Infants of Diabetic Mothers (IDM)	240
Neonatal Hyperthermia	241
Neonatal Cold Injury	241
Sclerema	241
Neonatal Necrotizing Enterocolitis	242
Transport of Sick Neonates	242
Maternal Medication and Adverse Effects on the Fetus	243
Maternal Medication and Adverse Effects on the Breastfed infant	244
Food and Environmental Agents and Adverse Effects on the Infant	244

PART THREE: PEDIATRIC INFECTION

18. Pediatric Viral Infections	247
<i>Ksh Chourjit, Suraj Gupte</i>	
Smallpox (Variola)	247
Monkeypox: A New Challenge	247
Chickenpox (Varicella)	248
Measles (Rubeola)	250
German Measles (Rubella, Three-day Measles) ..	253
Mumps (Epidemic Parotitis)	254
Poliomyelitis	255
Guillain-Barré Syndrome (GBS)	259
Acute Flaccid Paralysis (AFP) Surveillance	260
Infectious Mononucleosis	260
Dengue Fever	261
Chikungunya Fever	263
Japanese Encephalitis	263
Slow Virus Infection	264
Hydrophobia (Rabies)	264
Viral Hepatitis	264
Pediatric HIV / AIDS	265
Respiratory Syncytial Virus (RSV) Infection	268
Bird (Avian) Flu	269
Severe Acute Respiratory Syndrome (SARS)	269
19. Pediatric Bacterial Infections	270
<i>Karnail Singh, Suraj Gupte</i>	
HIB Disease	270
Pertussis (Whooping Cough)	271
Diphtheria	273
Epidemic Typhus	275
Typhoid Fever (Enteric Fever)	276
Brucellosis	280
Tetanus	280
Leprosy (Hansen Disease)	282

Syphilis	284
Leptospirosis	286
Meningococcal Infections	286
Tuberculosis	286
Anaerobic Infections	288
<i>Helicobacter pylori (H. pylori) Infection</i>	<i>288</i>
Opportunistic Infections	290
Nosocomial Infections	291
Toxic Shock Syndrome	294
Noma	294
20. Pediatric Parasitosis	296
<i>Suraj Gupte, Utpal Kant Singh</i>	
Malaria	296
Tropical Splenomegaly	301
Kala-azar (Black Sickness)	302
Filariasis	305
Tropical Eosinophilia	306
Common Parasitic Infestations of the Gut	307
Girdiasis	308
Amebiasis	309
Acanthamoeba	310
Cryptosporidiosis	311
Ascariasis	312
Oxyuriasis	313
Ancylostomiasis	313
Strongyloidiasis	314
Trichuriasis	314
Tapeworms	314
Neurocysticercosis	316
Hydatid Disease	317

PART FOUR: PEDIATRIC SUBSPECIALTIES

21. Pediatric Pulmonology	321
<i>Daljit Singh, Suraj Gupte</i>	
Clinical Evaluation of a Respiratory Case	321
Special Diagnostic Procedures	321
Upper Respiratory Tract Infection	323
Foreign Body in Lower Respiratory Tract	323
Adult Respiratory Distress Syndrome	323
Acute Bronchitis	324
Respiratory Syncytial Virus (RSV) Infection	324
Acute Bronchiolitis	325
Severe Acute Respiratory Syndrome (SARS)	326
Pneumonias	327
Bronchiectasis	330
Dry Pleurisy	331
Pleural Effusion	331
Empyema Thoracic	333
Lung Abscess	334
Bronchial Asthma	334

Tuberculosis	339	Autism	413
Recurrent Respiratory Infection	350	CNS Tuberculosis	417
The Child with Wheezy Chest	350	Meningitis	416
Cystic Fibrosis	350	Tuberculoma	420
Legionellosis	351	Encephalitis	421
Drowning and Near Drowning	351	Hydrocephalus	423
22. Pediatric Cardiology	353	Intracranial Space Occupying Lesions	425
<i>PP Maiya, Karunakara BP, Suraj Gupte</i>		Brain Abscess	425
Evaluation of a Cardiovascular Case	353	Subdural Effusion	426
Fetal Circulation	356	Subdural Hematoma	426
Circulatory Changes at Birth.....	356	Neurocysticercosis	427
Congestive Cardiac Failure	357	Intracranial Tumors	428
Congenital Heart Disease	359	Cavernous Sinus Thrombosis	428
• Ventricular Septal Defect (VSD)	361	Craniosynostosis	428
• Atrial Septal Defect (ASD).....	363	Febrile Seizures	430
• Patent Ductus Arteriosus (PDA)	365	Convulsive Disorders	430
• Tetralogy of Fallot (TOF)	366	Chronic/Recurrent Convulsions	431
• Fallot's Physiology	368	Status Epilepticus	432
• Tricuspid Atresia	369	Intractable Seizures	433
• Ebstein Anomaly	370	Phakomatosis (Neurocutaneous Syndromes)	434
• Transposition of Great Arteries (TGA)	371	Infantile Tremor Syndrome	434
• Total Anomalous Pulmonary Venous Return ..	372	Reye Syndrome	434
• Hypoplastic Left Heart Syndrome	373	Spasmus Nutans	435
• Aortic Stenosis	373	The Child with Ataxia	435
• Coarctation of Aorta Syndrome	374	The Child with Coma	436
Rheumatic Fever	376	Degenerative Brain Disorders	438
Rheumatic Heart Disease	382	Paraplegia	440
Infective Endocarditis	386	24. Pediatric Gastroenterology	443
Tricuspid Regurgitation	386	<i>Suraj Gupte, RA Anderson</i>	
Mitral Valve Prolapse Syndrome	389	Basics of Gastrointestinal Tract	443
Paroxysmal Atrial Tachycardia (PAT)	389	Special Investigative Work-up... ..	443
Sick Sinus Syndrome	390	Diarrheal Diseases: An Overview	444
Long QT Syndrome	390	Acute Diarrhea	444
Cardiomyopathy	391	Cholera	453
Takayasu Arteritis	390	Acute Bacillary Dysentery	454
Pericarditis	391	Pseudomembranous Colitis	455
Dextrocardia	393	Oral Rehydration Therapy (ORT)	456
Myocarditis	393	Persistent Diarrhea	459
Systemic Hypertension	394	Chronic Diarrhea	462
Interventional Cardiac Procedures	399	Celiac Disease	465
23. Pediatric Neurology	400	Cystic Fibrosis	467
<i>Suraj Gupte, Bhavana B Chowdhary</i>		Endemic Tropical Sprue	469
Developmental Aspects	400	Protein-losing Enteropathy	469
Neurologic Evaluation	400	Carbohydrate Malabsorption	470
Neural Tube Defects	402	Cow Milk Allergy	470
Pseudotumor Cerebri.....	404	Acrodermatitis Enteropathica	470
Acute Stroke Syndrome	405	Inflammatory Bowel Disease	471
Bell Palsy	406	Constipation	472
Guillain-Barre Syndrome	406	Recurrent Aphthous Stomatitis	473
Mental Retardation	408	Thrush	474
Down Syndrome	410	Geographic Tongue	474
Cerebral Palsy	413	Stress (Secondary) Ulcer Disease	474

Gastroesophageal Reflux Disease (GERD)	475	Anemias	524
Gastrointestinal Bleeding	476	Nutritional Anemia	525
Recurrent Abdominal Pain (RAP)	477	Physiologic Anemia of Prematurity	528
<i>H. pylori</i> Infections	478	Anemia of PEM	528
Food Allergy	478	Hypochromic Anemias Refractory to Iron	529
25. Pediatric Hepatology	481	Megaloblastic Anemia	530
<i>Suraj Gupte, RA Anderson</i>		Hemolytic Anemias	530
Basics of Hepatobiliary System	481	Characteristics of Hemolysis	531
Functions of Liver	481	Hereditary Spherocytosis	532
Manifestations of Liver Disease	481	Thalassemia	532
Diagnostic Work-up	481	Sickle-cell Anemia	535
Indian Childhood Cirrhosis	482	G-6-PD Deficiency	536
Reye Syndrome	484	Pyruvate Kinase Deficiency	536
Viral Hepatitis	487	Autoimmune Hemolytic Anemia	537
Fulminant Hepatitis	490	Methemoglobinemia	537
Fulminant/ Acute Hepatic Failure	490	Aplastic Anemia	537
Chronic Liver Disease	491	Mechanism of Coagulation (Hemostasis)	538
Chronic Hepatitis	492	Approach to a Child with Bleeding	539
Australia Antigen	494	Disseminated Intravascular Coagulation (DIC) ..	540
Portal Hypertension	494	Hemorrhagic Disease of the Newborn	542
Neonatal Cholestatic Syndrome	496	Hemophilia	544
Cholecystitis	498	Von Willebrand Disease	546
Choledochal cyst	498	Immune Thrombocytopenic Purpura (ITP)	546
Drug-induced Liver Injury	499	Wiskott-Aldrich Syndrome	548
Hepatomegaly	500	Drug-induced Thrombocytopenia	549
Liver Abscess	500	Anaphylactoid (Henoch-Schöenlein) Purpura ..	549
Wilson Disease	501	Purpura Fulminans	550
Approach to the Child with Ascites	501	Leukocyte Dysfunction	550
Orthotopic Liver Transplantation	502	Neutropenia	550
26. Pediatric Nephrology	504	Venous Thromboembolism	551
<i>Suraj Gupte, RM Shore</i>		Polycythemia (Erythrocytosis)	552
Basics of the Renal System	504	Hemopoietic Stem Cell Transplantation	552
Diagnostic Work-up	504	Blood Component Therapy	553
Congenital Malformations of Kidney and Urinary		28. Pediatric Oncology	555
Tract	505	<i>Suraj Gupte, AM Graham</i>	
Neurogenic Bladder	506	Leukemia	555
Obstructive Uropathy	506	Lymphomas	559
Proteinuria	507	Hodgkin's Disease	559
Hematuria	507	Non-Hodgkin Lymphoma	561
Urinary Tract Infection (UTI)	509	Wilms' Tumor (Nephroblastoma)	562
Acute Glomerulonephritis	510	Neuroblastoma	563
Renal Tubular Diseases	511	Hepatoblastoma	564
Acute Renal Failure (ARF)	513	Brain Tumors	565
Chronic Renal Failure (CRF)	513	Bone Tumors	566
Hemolytic-Uremic Syndrome (HUS)	516	Soft Tissue Sarcomas	567
Nephrotic Syndrome	517	Retinoblastoma	567
Hypertension	521	Thymoma	568
End-stage Renal Disease (ESRD)	522	Teratomas	568
Renal Osteodystrophy	522	Oncologic Emergencies	568
27. Pediatric Hematology	524	Bone Marrow Transplantation	569
<i>Jagdish Chandra, Suraj Gupte, Praveen C Sobti</i>		29. Pediatric Immunology	571
Developmental Aspects	524	<i>ML Kulkarni, Suraj Gupte, S Frank</i>	
		Immunologic System: Fundamentals	571

Immunodeficiency States	574	Ehler-Danlos Syndrome	603
• Primary	575	Molluscum Contagiosum	604
• Secondary	578	Warts	604
Diagnostic Approach in Immunodeficiency	578	Erythema Nodosum	604
Immunologic Basis of Autoimmune Disease	580	Skin Tuberculosis	604
Immunologic Basis of Allergy (Atopy)	580	Ectodermal Dysplasias	604
Immunologic Aspects of Malignancy	581	Acne	605
Immunodeficiency and Special Risks	581	Psoriasis	606
Intravenous Immunoglobulins (IVIG)	581	32. Pediatric Accidental Poisoning	608
Bone Marrow Transplantation	583	<i>Suraj Gupte, RK Kaushal</i>	
30. Pediatric Collagenosis	584	Accidental Poisoning: An Overview	608
<i>Suraj Gupte, DM Sharma</i>		Kerosene Oil Poisoning	612
Rheumatic Fever	584	Organic Phosphate Poisoning	612
Juvenile Rheumatoid Arthritis	584	DDT Poisoning	613
Systemic Lupus Erythematosus	586	Paracetamol Toxicity	613
Dermatomyositis	587	Barbiturate Poisoning	613
Polyarteritis Nodosa	587	Ibuprofen Toxicity	614
Scleroderma	588	Aspirin Poisoning	614
Mixed Connective Tissue Disease	588	Phenothiazine Toxicity	614
Goodpasture Syndrome	588	Chloroquine-induced Psychosis	615
Fascitis	588	Cyproheptadine Poisoning	615
Benign Rheumatoid Nodules	588	Iron (Iron Salts) Poisoning	615
Vasculitis Syndromes	588	Morphine and Other Opiates Poisoning	616
Kawasaki Disease	588	Datura (Atropine) Poisoning	616
Behcet's Disease	590	Lead Poisoning (Plumbism)	616
Wegener's Granulomatosis	590	Mercury Poisoning	617
31. Pediatric Dermatology	591	Lathyrism	617
<i>Suraj Gupte, NE Parsons</i>		33. Pediatric Envenomations	619
Atopic Dermatitis	591	<i>Suraj Gupte, RK Kaushal</i>	
Insect Bite Hypersensitivity	592	Snake Bite	619
Drug Eruption	592	Scorpion Sting	621
Scabies	593	34. Pediatric Endocrinology	623
Pediculosis	593	<i>Suraj Gupte, AW Koff</i>	
Ringworm Infections	594	The Endocrine Orchestra	623
Moniliasis (Candidiasis)	594	Hypothalamus and its Disorders	623
Diaper Rash	595	Pituitary and its Disorders	624
Prickly Heat	595	Short Stature	624
Seborrhea	595	Growth Hormone Deficiency (GHD)	624
Urticaria (Nettle Rash)	596	Thyroid and its Disorders	625
Pyodermas	596	Congenital Hypothyroidism (Cretinism)	625
Erysipelas	597	Acquired Hypothyroidism	629
Scalded Skin Syndrome (SSS)	597	Hyperthyroidism	629
Ichthyosis	598	Goiter (Thyromegaly)	629
Café-au-lait Spots	599	Parathyroid and Disorders	629
Albinism	600	Adrenal and its Disorders	630
Vitiligo	600	Gonads and their Deficiency	631
Leprosy	600	Undescended Testes (Cryptorchidism)	631
Hemangioma	600	Precocious Puberty	631
Telangiectatic Angioma	601	Delayed Puberty	632
Epidermolysis Bullosa	601	The Child with Ambiguous Genitalia	633
Erythema Multiforme	602	Diabetes Mellitus	634
Pemphigus	603	The Obese Child	638

35. Genetics in Pediatric Practice 642
Suraj Gupte, S Frank
 Genetics in Human Wellbeing 642
 Human Cell Division 642
 The Genes 643
 Types of Inheritance 643
 Variations in Expression of Genetic Traits 644
 Types of Genetic Disorders 644
 Human Genome Project 644
 The Chromosomes 644
 Chromosomal Disorders 645
 Inborn Errors of Metabolism 647
 Phenylketonuria 647
 Albinism 648
 Alkaptonuria 648
 Homocystinuria 648
 Maple Syrup Urine Disease 648
 Hartnup Disease 648
 Tyrosinemia 649
 Galactosemia 649
 Glycogen Storage Disease (GSD) 649
 Gaucher Disease 650
 Niemann-Pick Disease 650
 Mucopolysaccharidosis (MPS) 650
 Prenatal Diagnosis 653
 Dermatoglyphics 654
 Gene Therapy 655
 Genetic Counseling 655

36. Pediatric Neuromuscular Disorders 657
Vishnu Bhat B, Suraj Gupte
 Neuromuscular Transmission Disorders 657
 Motor Neuron Disorders 657
 Spinal Muscular Atrophies 658
 Developmental (Congenital) Disorders of
 Muscles 658
 Benign Congenital Hypotonia 658
 Muscular Dystrophies 659
 Pseudohypertrophic Muscular Dystrophy 659
 Endocrinal Myopathies 662
 Metabolic Myopathies 662

PART FIVE: PEDIATRIC SUPERSPECIALTIES

37. Pediatric Ophthalmology 667
Vijay Wali, Suraj Gupte
 Developmental Aspects 667
 Orbital Diseases 667
 Diseases of the Eyelids 669
 Diseases of the Lacrimal System 671
 Conjunctival Diseases 671
 Corneal Diseases 672
 Pupillary and Iris Abnormalities 673

Diseases of Lens 673
 Disease of the Uveal Tract 674
 Eye Movement and Alignment Diseases 674
 Refractory Errors 675
 Visual Disorders 675
 Diseases of the Retina and Vitreous 676
 Retinoblastoma 676
 Optic Nerve Diseases 677
 Systemic Medication and Ocular Damage 679
 Ocular Trauma 679

38. Pediatric Ear, Nose and Throat (ENT) Problems 680
Aniece Chowdhary, Suraj Gupte
 The Ear Disorders 680
 The Nose Disorders 683
 The Throat Disorders 685
 Intubation and Tracheostomy 687

39. Pediatric Dental Problems 689
NK Nagpal, Suraj Gupte
 Normal Dentition 689
 Dental Malocclusion 689
 Dental Caries 690
 Guidelines for Prevention of Dental Disease 691
 Cleft Lip and Palate 692

40. Pediatric Surgery 694
Devendra Gupta, Suraj Gupte
 Gastrointestinal Problems 694
 • Congenital Hypertrophic Pyloric Stenosis 694
 • Hiatal Hernia (Partial Thoracic Stomach) 695
 • Esophageal Atresia and Tracheoesophageal
 Fistula 695
 • Congenital Diaphragmatic Hernia (CDH) 696
 • Duodenal and Other Intestinal Atresias 697
 • Intestinal Malrotation 697
 • Intussusception 698
 • Hirschsprung's Disease 699
 • Meconium Plug Syndrome 699
 • Meconium Ileus 699
 • Meckel's Diverticulum 700
 • Necrotizing Enterocolitis 700
 • Appendicitis 700
 Anorectal Problems 700
 • Imperforate Anus and Other Malformations 700
 • Anal Fissure (Fissure-in-ano) 701
 • Perianal Abscess and Fistula 701
 • Pilonoidal Sinus and Abscess 701
 Anomalies Related to the Umbilicus 701
 • Vitellointestinal Fistula 701
 • Umbilical Polyp 701
 • Umbilical Hernia 701
 • Exomphalos (Omphalocele) and
 Gastroschisis 701

Anomalies of the Hepatobiliary System	702
• Extrahepatic Biliary Atresia (EHBA)	702
• Choledochal Cysts	703
• Cholecystitis (Calculus Type)	704
Genitourinary Problems	704
• Obstructive Uropathy	704
• Renal Stone	704
• Primary Bladder Stone Disease	705
• Priapism	705
• Tight External Urethral Meatus (Meatal Stenosis)	706
• Phimosis and Paraphimosis	706
• Hypospadias and Epispadias	706
• Ambiguous Genitalia	706
Inguinoscrotal Problems	706
• Inguinal Hernia	706
• Hydrocele	706
• Undescended Testes (Cryptorchidism)	707
• Epididymo-orchitis	707
• Acute Scrotum	707
Head and Neck Problems	707
• Cleft Lip and Cleft Palate	707
• Cystic Hygroma (Lymphangioma)	707
• Thyroglossal Cyst	708
• Brachial Cyst	708
• Brachial Sinus and Fistula	708
• Sternomastoid Tumor (Sternocleidomastoid Tumor)	708
Miscellaneous Problems	708
• Abscess	708
41. Pediatric Orthopedics	709
<i>Surya Bhan, Suraj Gupte</i>	
Congenital Deficiency of Long Bones	709
Club Foot	709
Flat Foot	709
Radial Club Hand	709
Trigger Thumb	710
Polydactyly	710
Syndactyly	710
Congenital Constriction Bands/Rings	710
Congenital Pseudoarthrosis of the Tibia	710
Dislocation of Patella	710
Knock Knee	710
Bow Leg	710
Cleidocranial Dysostosis	710
Hemihypertrophy	711
Slipped Capital Femoral Epiphysis	711
Developmental Dysplasia of the Hip	711
Scoliosis	712
Kyphosis	712
Genetic Skeletal Dysplasias	712
• Osteogenesis Imperfecta	712

• Marfan Syndrome	713
• Arthrogyposis Multiplex Congenita	714
• Achondroplasia	714
• Pseudoachondroplasia	715
• Osteopetrosis	715
• Osteochondritis	715
• Limb Length Discrepancy	715
Infections/Inflammations of Bones and Joints ..	716
• Acute Septic (Pyogenic) Arthritis	716
• Osteomyelitis	716
• Tuberculosis of Bones and Joints	717
• Transient Synovitis of the Hip	718
• Rheumatoid Arthritis	718
• Bone Tumors	718
Pediatric Sports Medicine	718
Pediatric Fractures	719

PART SIX: MISCELLANEOUS AND UNCLASSIFIED ISSUES

42. Miscellaneous and Unclassified Issues	723
<i>Suraj Gupte</i>	
Child Adoption	723
Child Abuse and Neglect	724
Infantile Tremor Syndrome	726
Sudden Infant Death Syndrome (SIDS)	728
Progeria	729
Chronic Fatigue Syndrome	730
Growing Pains	730
Histiocytosis	730
Sarcoidosis	731
Some Minor Problems of the Newborn, the Infant and the Young Child	731
Modern Imaging Techniques	733
Computers: Applications in Pediatrics	735
Heat Injury	736
Emerging and Re-emerging Infections	737
Evidence-based Medicine (EBM)	737

PART SEVEN: PEDIATRIC PROCEDURES

43. Pediatric Practical Procedures	743
<i>Vasudev Vatwani, Suraj Gupte</i>	
General Rules/Precautions	743
Restraint and Positioning	743
Intramuscular Injection	743
Subcutaneous Injection	744
Intradermal Injection	744
Venipuncture	744
Intravenous Infusion	745
Arterial Puncture	747

Intraosseous Infusion	747
Subcutaneous Infusion	748
Intraperitoneal Infusion	748
Rectal Infusion	748
Bone Marrow Aspiration	748
Bone Marrow Trephine	749
Lumbar Puncture	749
Subdural Puncture or Tap	749
Ventricular Tap	750
Thoracentesis	750
Pericardial Puncture	750
Abdominal Paracentesis	750
Suprapubic Bladder Aspiration	751
Heel Puncture	751
Liver Biopsy	751
Kidney Biopsy	751
Intubation	752
Lymph Node Biopsy	752
Fine Needle Aspiration	752
Gastric Lavage	753
Manual Removal of Foreign Body from	
Airway	753
Cardiac Resuscitation	754
Assisted Ventilation	754
44. Pediatric Laboratory Procedures	756
<i>Suraj Gupte, Bhavna B Chowdhary</i>	
Blood Examination	756
Urine Examination	758
Stool Examination	760
CSF Examination	762

PART EIGHT: PEDIATRIC SYNDROMES

45. Pediatric Syndromes	767
<i>Suraj Gupte</i>	

PART NINE: PEDIATRIC DRUG DOSAGES

46. Pediatric Drug Dosages	775
<i>Lalita Bahl, Suraj Gupte</i>	

Appendices	785
A Useful Normal Laboratory Values	785
B Important Conversions	785
C International Days	788
D World Health Day (April 7) Themes	788
E World Breastfeeding Week	
(August 1 To 6) Themes	788
F The IMNCI Case Management Process	789
G IMNCI Case Management in the Outpatient Health	
Facility, First-level Referral Facility and at Home	
for the Sick Young Infant up to 2 Months Age	790
H IMNCI Case Management in the Outpatient Health	
Facility, First-level Referral Facility and at Home	
for the Sick Child From Age 2 Months up to	
5 Years	791
I Syllabus Module of Didactic Teaching for	
Undergraduates As Per Recommendation of the Medical	
Council of India (MCI)	792
J Final MBBS Part II (Pediatric) Examination	793
K Important Websites on Pediatrics and Allied Fields ...	793
L New (2006) WHO Child Growth Standards	795
Index	807

**THE SHORT
TEXTBOOK OF
PEDIATRICS**

PART ONE



Core Pediatrics

CHAPTER



1

Pediatric History-taking and Clinical Examination

Suraj Gupte, Rita Smith

GOALS

Ever since the time of Hippocrates, history-taking and clinical examination of the child occupy pride of place as a remarkable art that builds up gradually on a good foundation through repeated exposures, application of knowledge and guided practical experience spread over years and years. Major goals of history-taking and clinical examination are:

1. Data collection, both from history and physical examination
2. Arriving at clinical diagnostic probabilities
3. Planning investigations to confirm the clinical diagnosis
4. Treatment plan.

THE ART OF HISTORY TAKING

The best person to give the history ("informant") is the mother of the child or someone else responsible for his care. If the child is old enough to communicate information, he should also be interviewed. History obtained from father, uncles, aunts or grandparents, who have not been deeply involved in child's care, is less reliable.

As far as possible, history should be taken in a room with minimum of noise and disturbance and an environment that is child-friendly.

The approach to the child as also the informant should be friendly. Let the informant tell the story as she sees it. You may later put leading questions to fill in the gaps and for detailed elaboration. Avoid putting trying and embarrassing questions. Creating a feeling of guilt or shame in the informant's mind will only make your job difficult. Yet, important information has got to be obtained and. This may require extra-tact in

handling the situation. At times, it may be more workable to obtain some such information rather later in the interview, during the clinical check-up or even at a subsequent interview.

The case-sheet must have a record of clear and precise information about the history in chronologic order. Besides the entries regarding name, age and sex, parents' name and address, etc. the recording should be in the following order with marginal modifications as and when indicated.

1. Basic information
2. Presenting complaints
3. History of present illness
4. History of past illness
5. Birth history
 - Antenatal
 - Natal
 - Perinatal, and
 - Postnatal
6. Developmental history (Milestones)
7. Dietary history
8. Immunization history
9. Personal history
10. Family history
11. Socioeconomic history

Basic Information

It should include child's name, sex, parentage and address along with the name of the informant.

Presenting Complaints

The first question to be asked is: "Well, what is the main complaint? This leads the informant to state the problem. Mind you, here reply is to be written down in her own words rather than in medical jargons.

It is wrong to convert “has not passed urine since yesterday” to “anuria-1 day.” So, presenting complaints must be in informant’s own account and must include the duration also.

Furthermore, the complaints need to be recorded in chronologic order, i.e. in order of occurrence.

You must obtain detailed information about the various complaints such as cough, fever, breathlessness (Box 1.1), vomiting, diarrhea, abdominal pain, hematemesis, bleeding per rectum, appetite, micturition, failure to thrive, swelling (edema), rash, jaundice, cyanosis, pallor, etc. depending on the merits of the case.

Box 1.1: Grades of breathlessness (Dyspnea)

Grade 1 (Slight): Occurring on unaccustomed (more than average), exertion, e.g. running, playing a game (outdoor)

Grade 2 (Moderate): Occurring on ordinary exertion, e.g. walking at normal pace, climbing upto sheer 2 rugs.

Grade 3 (Considerable): Occurring even without ordinary exertion

Grade 4 (Gross): Occurring even at rest.

History of Present Illness

After the chief complaints, you should record the details of the present illness. When was the child quite well? How and when did the present problem start? How was its further progression? Was it stationary, improving or worsening? What were the new symptoms? Any aggravating/alleviating factors? Pertinent negative data that may have bearing on the diagnoses that are crossing your mind? Any treatment given?

History of Past Illnesses

How was child’s previous health? Make a note of duration, dates and types of various illnesses. Also, state if any treatment was given. History of recurrent diarrhea and recurrent sinopulmonary infection with failure to thrive despite good dietary intake is very suggestive of cystic fibrosis. Umbilical sepsis in neonatal period may well be a precursor of portal hypertension later in life. Likewise, in a child who present with acute wheeze, a history of similar episodes in the past may well strongly point to the diagnosis of bronchial asthma.

Birth History

You should elucidate the factors that may have bearing on child’s health before, during and after birth.

Antenatal It is important to know about mother’s health during pregnancy. How was her diet? Any history of illnesses such as rubella, syphilis, toxemia, diabetes, hypertension, heart disease, tuberculosis, exposure to radiation, or drug intake? Maternal intake of such antiepileptic drugs (AEDs) as phenytoin, valproate and trimethadione may have teratogenic effect on the fetus. Do ask about blood group incompatibility between the parents.

Natal Was it a hospital or home delivery? Who conducted it—a qualified doctor or midwife, or simply an untrained *dail*. Was the delivery normal or not? What was baby’s birth weight? Did he look healthy or sick? Any cyanosis? Any respiratory distress? Cry? Was any resuscitation needed?

Postnatal Apgar score? Any jaundice, cyanosis, convulsions, congenital anomalies, or birth injury noticed during the neonatal period. Any resuscitation measures employed after delivery? How was the umbilical cord cut? Any pus oozing out of it? Any suckling difficulty? What was the birth weight? Excessive weight loss? When was the meconium passed? Absence of meconium passage may point to intestinal obstruction; a passage after 24 hours may suggest cystic fibrosis. When was the urine passed? Voiding of urine after 48 hours indicates renal agenesis or an obstruction in the system.

Developmental Milestones

You must find out when the child gave first social smile and learned head-holding, sitting with and without support, crawling, standing and walking with and without help and talking meaningful words and sentences. Any dental eruption and the timing?

Also ask about control over bowel and bladder, both during day and night.

Any regression in milestones? Any period of growth failure or unusual growth should also be elicited.

It is important to know about school grade and quality of work.

Immunization Status

You must ask about the various vaccinations (including the new vaccines, optional vaccines, and pulse polio) received by the child with dates, if available. If certain vaccination has been omitted, find out why. Also, ascertain if any vaccination caused some complication(s).

Dietetic History

Was the child breast or bottle fed? If on formula, how was it prepared? Find out about sterilization of the feeding equipment and whether the dilution of the formula was as recommended or much too much. Any feeding difficulties?

When were the semisolids and solids introduced? Find out more details about the weaning foods and how they were given and in what quantity.

When were vitamin and mineral supplements started?

It is important to provide some details of the current dietary intake. Does child's appearance match the mother's story about his intake?

Also, you must get information about child's food "likes" and "dislikes". How does he react to eating?

Any food allergy (cow milk, egg, soybean).

Personal History

How are child's relations with the sibs, other family members and children in the school? Is he a difficult child? Does he cling to mother's apron strings? Is he negativistic? Is he outgoing? How are his eating, sleep, bowel and bladder habits? History of pica, enuresis, breath-holding, tics and temper-tantrum should be specially elicited.

Family History

Apart from history of consanguinity (Box 1.2), the health status of the siblings, parents and grand-parents should be recorded. In case of infectious and familial diseases, history of such illness in the family members must be pointedly sought. In inherited disorders, it is advisable to make a family tree (Fig. 1.1). In disorders

Box 1.2: Consanguinity

- 1st degree : Parent, sibling, child
- 2nd degree : Uncle, aunt, niece
- 3rd degree : First cousin

like Down syndrome, it is good to know the ages of the parents.

Socioeconomic Status

How much is the family income? It may be significant to know about the occupation of the parents and the housing, school and play facilities available for the child.

System Review

At the end of history recording, it is advisable to review each system in turn so that nothing vital is missed (Box 1.3).

Box 1.3: System review

- *Ear, Nose and Throat:* Ear discharge, earache, hearing, stuffy or running nose, postnasal discharge, sneezing, frequent colds, sore throat, mouth breathing, snoring.
- *Teeth:* Eruptions at present, time of first tooth, whether in line with other siblings.
- *Heart and chest:* Breathlessness, cough, expectoration, wheeze, cyanosis, palpitations, edema, chest pain.
- *GIT:* Diarrhea, vomiting, constipation, pain abdomen, abdominal lump.
- *Liver:* Jaundice, deep urine, light stools, smell in breath.
- *Genitourinary* Vaginal discharge, menses, visible anomalies of penis, testis or labia and clitoris, dysuria, polyuria, hematuria, pyuria, enuresis.
- *Neuromuscular:* Headache, dizziness, convulsions, ataxia, muscle or joint pains, postural deformities, paralysis.
- *Endocrines:* 'Faces, activity, obesity, disturbance of growth, polydipsia, visible goiter.
- *Special Senses:* Taste, hearing, vision, smell, pain.
- *General* Weight loss or gain, easy fatigability, growth curve, puberty, skin changes, temperature sensitivity.

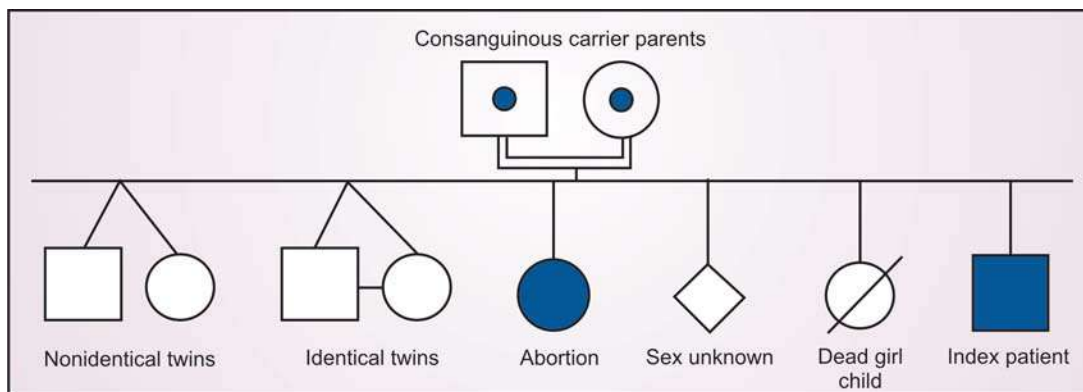

Fig. 1.1: Guidelines for construction of family pedigree (genetic) diagram

1 THE ART OF PHYSICAL EXAMINATION

Before embarking on physical examination, it is important to get friendly with the child and win his confidence. This can easily be done while you are taking the history from the mother. During this period, you may also make certain observations about the child. Is he acutely sick? Does he take interest in the surroundings? Is he apprehensive, apathetic or hyperactive? Does he have any obvious malformation or deformity? Is there anything characteristic about his appearance?

The child may be examined while he is in mother's lap or over the shoulder. The dress should be removed bit by bit to avoid resistance from a shy child and to prevent exposure in a chilly weather. Physical examination of a child is from "region to region". The examiner must first develop a friendly rapport with him. Examination which is likely to be "irritating" should be done towards the end. You must make sure that the whole of the body from scalp hair to tips of the toes is properly inspected. The sequence of examination depends upon the cooperation received from the child. As a rule, uncomfortable procedures such as examination of throat, ear or rectum should be left to the last. Else, an irritated, panicky child is going to be a difficult subject to examine. It is also wise to avoid a prolonged examination.

Furthermore, it is of distinct value to highlight the positive findings and put question marks (?) against the doubtful findings which may well be crosschecked later.

General Appearance

Does the patient look acutely sick? Is there any suggestion of a respiratory distress? Does he look mentally retarded? Is there any evident congenital defect? Is he comfortable, cooperative and interested in the surroundings? Is he wasted, obese or average?

Note his cry. A high-pitched shrill cry may suggest meningitis. A weak cry may be the result of grave illness, respiratory muscle weakness or generalized weakness. A child in agony because of pain may give a strong cry.

A child appearing comfortable in the bed or on the table but irritable in mother's lap, the so-called "paradoxical irritability", should arouse suspicion of such conditions as poliomyelitis, scurvy, infantile cortical hyperostosis or acrodynia.

Table 1.1: Vital signs at different ages

Age group	Pulse/min	Respiration/mm	Temperature (°C)
Newborn	140	40	36.0 to 37.0
1 year	120	30	36.5 to 37.5
5 years	100	20	37.0 ± 0.2
10 years	90	18	37.0 ± 0.2
Above 10 years	80	18	37.0 ± 0.2

A "frog-like" posture may mean poliomyelitis or scurvy.

It is advisable to make a note of vital signs at this stage (Table 1.1).

Anthropometry

It is essential to record child's weight, height or length, head, chest, and mid-upper-arm circumferences (MAC) and, if possible, skin-fold thickness. In certain instances, it is of value to measure the upper and lower segments and arm span. For details, see Chapter 3.

Skin

Note its color for cyanosis (Box 1.4), jaundice, pallor and caroteneemia.

Box 1.4: Cyanosis

Definition: Bluish discoloration of skin and mucous membrane.

Peripheral: Present only in the periphery, i.e. limbs as a result of exposure to excessive cold, Raynaud's phenomenon, arterial thrombosis, superior vena cava syndrome or traumatic compartment syndrome.

Central: Present in central regions as a result of pulmonary (cyanotic congenital heart disease), pulmonary (RDS, congenital diaphragmatic hernia, persistent fetal circulation, pneumonia, etc.), hematologic (polycythemia, hypercoagulability, methemoglobinemia, etc) or neurologic (encephalitis, encephalopathy, etc) disease.

Look for pigmentation. Localized bluish spots, usually on the buttocks and the back, are the so-called "mongolian spots". They are self-limited, having no clinical significance. "Cafe-au-lait spots" may be associated with phacomatosis. Reticular pigmentation may be a feature of megaloblastic anemia or infantile tremor syndrome. In Addison disease, the pigmentation usually gives the skin dirty brown color and may also be present at the gum margins and cheeks.

Skin turgor is lost in dehydration and marasmus. In order to elicit pitting edema, greater pressure requires to be applied in children than in adults.

Box 1.5: Types of fever

Continuous Fever: Present throughout the day with fluctuation $< 1^{\circ}\text{C}$ in 24 hours. Examples.: Pneumonia, UTI, infective endocarditis

Remittent Fever: Present throughout the day with fluctuation of $>1^{\circ}\text{C}$ in 24 hours.

Intermittent Fever: Present only during certain periods of the day. In between, temperature is normal. Examples: Malaria, kala-azar, juvenile rheumatoid arthritis.

Quotidian Fever: Intermittent fever occurring daily

Tertian Fever: Intermittent fever occurring on alternate days

Quartan Fever: Intermittent fever occurring at 2 days interval

Fever with Rigors/Chills: It is encountered in infectious processes such as malaria, UTI, septicemia, etc.

Presence of rashes, petechiae, ecchymoses or specific diseases should also be observed.

While examining skin, it is appropriate to look for subcutaneous nodules over bony prominences in suspected cases of rheumatic fever or rheumatoid arthritis (Box 1.5).

Lymph Nodes

Note the location, size, consistency, mobility, tenderness and warmth of lymph nodes, particularly in the suboccipital, preauricular, anterior and posterior cervical, submaxillary, sublingual, axillary, epitrochlear and inguinal regions.

Posterior auricular and suboccipital adenitis may be the result of otitis externa, scalp infection or lice.

Palpable nodes up to 1 cm in inguinal region and up to 3 mm in rest of the areas may well be passed as within normal limits in healthy children.

Head

It is important to measure its circumference at mid forehead anteriorly and the most prominent part of the occiput posteriorly (Table 1.2). At birth, it measures 34-35 cm. Then a gain of 2 cm/month for first 3 months (total gain 6 cm), 1 cm/month in next 3 months (total gain 3 cm) and 0.5 cm in the subsequent 6 months (total gain 3 cm) occurs. Thus, there is a total gain of 12 cm by the end of the first year. During second and third years, when it measures 47 cm increase is 2 cm and 1.5 cm, respectively. During 3-14 years, it is 2.5 cm. At 14 years, head circumference is 53 cm.

You should note its shape as well—whether scaphocephaly, oxycephaly (acrocephaly), brachycephaly or plagiocephaly. Palpation of the sutures may

reveal evidence of craniosynostosis. In hydrocephalus, sutures may be separated. Craniotables may be demonstrated in occipitoparietal region and should arouse search for other signs of rickets, prematurity, osteogenesis imperfecta or syphilis. In suspected hydrocephalus, it is desirable to do transillumination of the head in darkroom. Positive “crack-pot” or Macewen sign on percussing the skull with a finger does not always suggest hydrocephalus. It may well be positive normally as long as the fontanels are open. Since posterior and lateral fontanels close very early in infancy, it is the anterior fontanel that has clinical value. It usually closes between the ages of 9 to 18 months. Early-closure suggests craniosynostosis and late closure rickets, congenital hypothyroidism, malnutrition, hydrocephalus, syphilis, etc. A truly bulging anterior fontanel suggests raised intracranial tension or pseudotumor cerebri. A depressed fontanel is a sign of significant dehydration. An intracranial bruit on auscultation, particularly in temporal region, may well be a normal finding or evidence of an aneurysm, or facial hemangioma.

While examining the head, you should inspect hair for color, texture, sparseness and easy pluckability. Light-colored, sparse, silky or coarse, easily pluckable hair is usually seen in kwashiorkor or infantile tremor syndrome. Localized alopecia without any sign of infection is seen in trichotillomania. With presence of infection and pruritic lesions, it should suggest ringworm.

Face

It should be examined for expression, asymmetry, paralysis, bridge of nose, hypertelorism/pseudo-hypertelorism, distribution of hair, size of the maxilla and mandible and tenderness over sinuses. Dull and expressionless facies are commonly seen in mental retardation. So characteristic are the facies in such disorders as Down syndrome, cretinism (congenital hypothyroidism), adenoids and gargoylism (Hurler/Hunter syndrome) that a well conversant observer is often in a position to make the diagnosis from a distance.

Eyes

You should examine the eyes for photophobia, visual acuity, mongoloid or antimongoloid slant, epicanthal fold, Brushfield spots, exophthalmos or enophthalmos,

Table 1.2: Certain observations and their significance in respiratory system examination

<i>Observation</i>	<i>Significance</i>
Respiratory rate > 60/minute (newborn)	Tachypnea
Working of accessory muscles like ala nasi	Respiratory distress
Stridor obstruction	Upper airway (supratracheal) inspiratory
Grunting	Lung parenchyma disease (pneumonia), HMD
Wheezing	Expiratory obstruction (asthma)
Moderate tachypnea with chest retraction	Parenchyma disease (pneumonia), HMD
Marked tachypnea without chest retraction aspiration in the	Bronchial disease (asthma), meconium newborn
Silent dyspnea, inability to phonate, paradoxical/seasaw breathing	Respiratory muscle paralysis (GBS, acute respiratory failure)
Severe tachypnea but no manifestations of respiratory disorder	Metabolic acidosis
Peripheral cyanosis	Moderate oxygen desaturation
Central cyanosis	Extreme oxygen desaturation
Clubbing	Chronic hypoxia
Increased tactile vocal fremitus (TVF)	Pneumonia, pure pleural effusion
Decreased TVF	Pneumothorax, pleural effusion with underlying collapse
Harrison sulcus	Chronic airway obstruction (asthma)
Chest tenderness	Empyema
Hyperresonant note	Emphysema, pneumothorax
Hyporesonant note	Collapse/consolidation
Stony dull note	Pleural effusion
High-pitched bronchial breathing	Consolidation
Low-pitched bronchial breathing	Cavity
Post-tussive suction	Cavity
Succession splash	Hydropneumothorax
Pleural rub	Pleuritis
Fine crepitations(crackles)	Alveolar lesion
Coarse crepitations (crackles)	Bronchial lesion
Rhonchi (wheeze)	Bronchospasm, bronchial obstruction
Conducted sounds	URI, laryngomalacia
Signs of pneumonia anteriorly and in upper half	Upper lobe pneumonia
Signs of pneumonia anteriorly and in middle half	Middle lobe pneumonia
Signs of pneumonia posteriorly	Lower lobe pneumonia
Clinical signs defying any pattern	Mediastinal tumor

pupils, cataract, corneal opacities, squint, nystagmus, xerophthalmia, or Kayser-Fleisher ring around the iris.

Ophthalmoscopy is important in selected cases.

Nose

It should be examined for patency, discharge, bleeding, deviated septum, flaring of nostrils, foreign body, polyp and depressed bridge.

Mouth and Throat

Note any unusual shape, cleft lip, nevi, lesions at the corners, ulcers on buccal mucosa, tongue or pharynx, spongy gums, dental caries or malocclusion, opening of the Stensen duct at the level of second upper molar, Koplik spots, hard and soft palate, tonsils and postnasal discharge.

If a baby can move his tongue over the alveolar margin (which is invariably the case), the so-called “tongue-tie” is out. Fissuring of the tongue occurs in many cases of Down syndrome. Tremors may suggest Werdnig-Hoffmann disease. Frenular ulcer is a feature of pertussis. Macroglossia may be encountered in cretinism, and gargoylism. Glossoptosis occurs in association with micrognathia and cleft palate in Pierre-Robin syndrome.

Ears

You must note the shape, size and position of the ears. Deformities may well be a pointer that kidney anomalies are also present. Low-set ears may be associates of other congenital anomalies seen in certain syndromes such as Treacher-Collins syndrome, Apert

syndrome, carpenter syndrome, or Noonan syndrome. Such an ear lies below an imaginary line joining the lateral angle of the eye to the external occipital protuberance.

It is useful to examine the ear drum. Mastoid bone should be percussed for tenderness. Hearing should also be tested. A valuable bedside test consists in observing an infant's response to sound. In normal hearing, he will turn his head to the direction of the sound.

Neck

Neck is examined for head-holding, swelling, torticollis, JVP (Fig. 1.2), sinuses or fistulas. Any webbing, bull neck or position of trachea should also be noted.

Chest

The size, shape and symmetry are carefully examined. A special note should be made about presence of any retraction (suprasternal, intercostal), rachitic rosary, pigeon chest deformity, funnel chest, gynecomastia, etc.

In examination of lungs, it is important to note the type of breathing, dyspnea, chest expansion, cough, vocal dullness, percussion note, breath sounds, crepitations, wheeze, etc. Remember that in young children, breathing is mainly abdominal.

Table 1.2 gives significance of certain observations in examination of respiratory system.

You should examine the heart for location of apex beat, its intensity, precordial bulging, thrills, size, shape, sounds, murmurs, friction rub, etc.

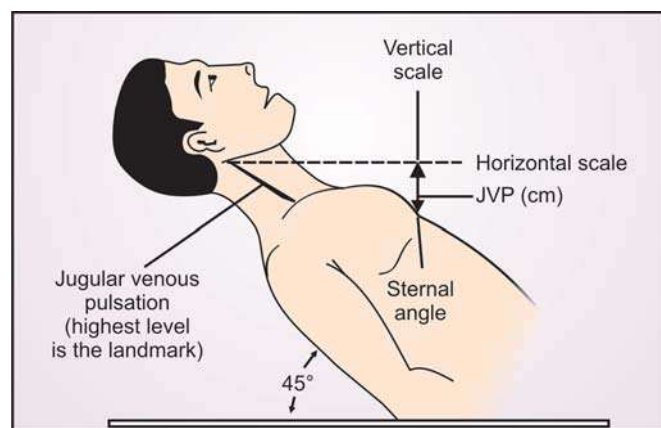

Fig. 1.2: Measurement of JVP

Remember that heart should be examined while the child is erect, recumbent and turned to left. Also that extrasystoles may be heard in many normal children. Likewise, sinus arrhythmia may be a normal finding in childhood. Cardiac examination must in particular be very careful, noting the presence of a precordial bulge, substernal thrust, apical heave or a hyperdynamic precordium, thrills (both systolic and diastolic), aortic bruits, etc.

Auscultation of the precordium requires patience, first concentrating on the characteristics of the individual heart sounds and then on the murmurs. An accentuated or loud first heart sound over the mitral area suggests tachycardia, hyperkinetic heart syndrome, hyperthyroidism or mitral stenosis. In mitral regurgitation and myocarditis, the first heart sound over the mitral area is particularly faint. In tricuspid atresia, the first heart sound over the tricuspid area is accentuated or loud. The second sound is split little beyond the peak of inspiration; it closes with expiration. A wide splitting is encountered in pulmonary stenosis, tetralogy of Fallot, atrial septal defect, total anomalous venous return and Ebstein anomaly. A narrow splitting points to pulmonary hypertension. The third sound is best heard with the bell at the apex in middiastole, especially if the child assumes a left lateral position. It is of significance in the presence of signs of congestive cardiac failure and tachycardia in which situation it may merge with the fourth sound. The latter, coinciding with atrial contraction, may be heard a little before the first sound in late diastole. The phenomenon of poor compliance of the ventricle with an exaggeration of the normal third sound associated with ventricular filling is termed "gallop rhythm".

After the heart sounds, attention should be focussed on clicks. Aortic systolic clicks, best heard at the left lower sternal border occur, in aortic dilatation as in aortic stenosis, tetralogy of Fallot, or truncus arteriosus. Pulmonary ejection clicks, best heard at the left midsternal border, occur in pulmonary stenosis. In prolapse of the mitral valve, a mid-systolic click precedes a late systolic murmur at the apex.

Murmurs need to be described as to their timing, intensity, pitch, area of highest intensity and transmission.

Whether a particular murmur is just functional (innocent with no significance) or has a pathological

1 origin (congenital heart disease) must be decided. Murmurs are audible sounds arising from the flow of blood through blood vessels, valves or heart chambers evincing turbulence. In children, because of closeness of the heart to the thin chest wall, murmurs are relatively more easily heard. As a rule, narrower the blood vessel or opening, or higher the turbulence of flow, louder is the murmur. Murmurs are usually classified as systolic, diastolic, and continuous.

Systolic murmurs may be ejection, pansystolic or late systolic. An ejection systolic murmur rises to a crescendo in midsystole. It is, as a rule, coarse. Examples of such murmur are aortic stenosis, aortic coarctation, pulmonary stenosis and atrial septal defect. A pansystolic murmur occurs all through systole. It is caused by flow of blood through a septal defect (ventricular septal defect) or an incompetent mitral or tricuspid valve (mitral incompetence), tricuspid incompetence, or a patent ductus arteriosus. A late systolic murmur is heard well beyond the first sound and stretches to the end of systolic phase (mitral valve prolapse). According to intensity, systolic murmurs are categorized into six grades (Table 1.3).

Diastolic Murmurs may be

1. High-pitched blowing along the left sternal border, indicating aortic insufficiency or pulmonary valve insufficiency.
2. Early short, lower-pitched protodiastolic along the left mid and upper sternal border, indicating pulmonary valve insufficiency or after repair of pulmonary outflow tract in such conditions as tetralogy of Fallot.
3. Early diastolic at the left mid and lower sternal border, indicating atrial septal defect or atrial valvular stenosis.

Table 1.3: Six grades of systolic murmurs (Keek's classification)

Grade	Characteristics
1.	Faintest, requiring very careful auscultation in noise-free environments (consultant's murmur); innocent
2.	Soft though slightly louder; usually innocent
3.	Moderately loud without a thrill; may be innocent or organic.
4.	Loud, accompanied by a thrill; always organic
5.	Very loud, accompanied by a thrill; still needs stethoscope in contact with chest; always organic
6.	Loudest possible, accompanied by a thrill heard with stethoscope not necessarily in contact with the chest; always organic.

4. Rumbling middiastolic at the apex after the third heart sound, indicating large right to left shunt or mitral insufficiency.
5. Long diastolic rumbling murmur at the apex with accentuation at the end of diastole (presystolic), indicating anatomical mitral stenosis.

A *continuous murmur* (machinery murmur) is a systolic murmur, best heard over the second and third left parasternal spaces, that extends into diastole. It indicates a patent ductus arteriosus. It must be differentiated from a pericardial friction rub, as also from a venous hum.

Remember, over 30% children may have a murmur without significant hemodynamic abnormalities. Typically, the so-called "innocent murmur" is heard in the age group 3 to 7 years, occurs during ejection, is musical and brief, is attenuated in the sitting position, and is intensified by pyrexia, excitement and exercise. As the child grows, such a murmur shows a tendency to be less well heard and may regress fully.

It is of help to apply the time-honored Nada's criteria for presence of heart disease in suspected cases (Chapter 18).

Abdomen

It is helpful to bear in mind the *anatomic topography* (Fig. 1.3) and to examine the abdomen when it is relaxed, i.e. when the infant is taking his feed or sucking at the "sugar tip", the mother's lap or shoulder (when the child is struggling and abdomen can be examined from the back) is the best place for

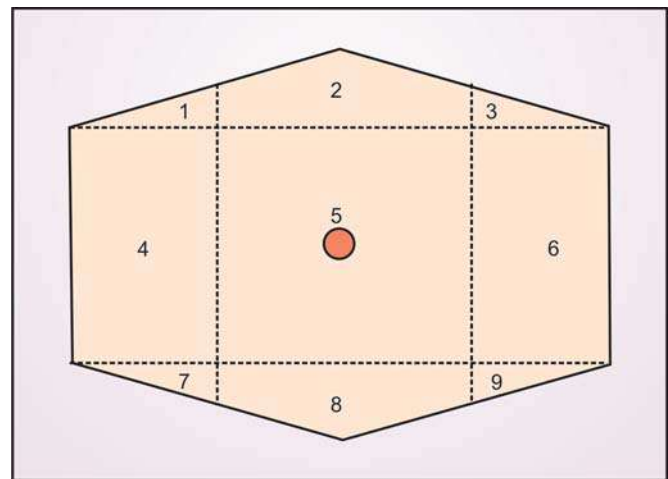

Fig. 1.3: Anatomical topography of the abdomen: Region 1 represents right hypochondrium; 2 epigastrium; 3 left hypochondrium; 4 right lumbar; 5 umbilical; 6 left lumbar; 7 right iliac; 8 hypogastrum; 9 left iliac

abdominal examination. An important tip is to do palpation only when the child breathes and abdomen is relaxed (*ballotment method*). Note its size and contour, distention, movement with respiration, visible peristalsis, umbilicus, hernias, local or rebound tenderness, palpable organ or lump, hyperresonance, shifting dullness, alteration in bowel sounds, etc. Gentle palpation is of greater value than deep, particularly in the case of spleen. Secondary umbilical hernia is common during first 2 years of life and usually regresses spontaneously.

Palpability of liver should be determined in both the midline and the right nipple line. As a rule, liver is normally palpable up to 2 cm below the costal margin until age 4 years. Therefore, rather than just palpability of liver, it is more reliable to measure the liver span (distance between upper margin of liver dullness and lower edge of liver in the midclavicular line). Normal liver span is 4.5-5.0 cm at 1 week. By 12 years, it goes up to 6.0-6.5 cm in girls and 7.0-8.0 cm in boys.

The tip of spleen is palpable far more laterally in infants and young children than in older children (Fig. 1.4). In infants until the age of 2-3 months, spleen may be normally palpable.

Splenic size may be graded (Fig. 1.5, Box 1.6):

Box 1.6: Grading of splenic size

- Grade 1:** Normal, not palpable even on deep inspiration
- Grade 2:** Palpable just below costal margin, usually on deep inspiration
- Grade 3:** Palpable below costal margin but not projected beyond a horizontal line half way between costal margin and umbilicus. This projection needs to be ascertained along a line dropped vertically from the left nipple.
- Grade 4:** Lowest palpable point approaching the umbilical level but not below a line drawn horizontally through umbilicus.
- Grade 5:** Lowest palpable point below umbilical level but not projected beyond a horizontal line situated halfway between umbilicus and symphysis pubis.
- Grade 6:** Lowest palpable point beyond lower limit of grade 4.

Genitalia

In case of male genitalia, look for circumcision, urethral (meatal) opening, hypospadias, phimosis, paraphimosis, hydrocele, hernia, and undescended testes. Make sure you have warmed your hands before you begin to examine the testes.

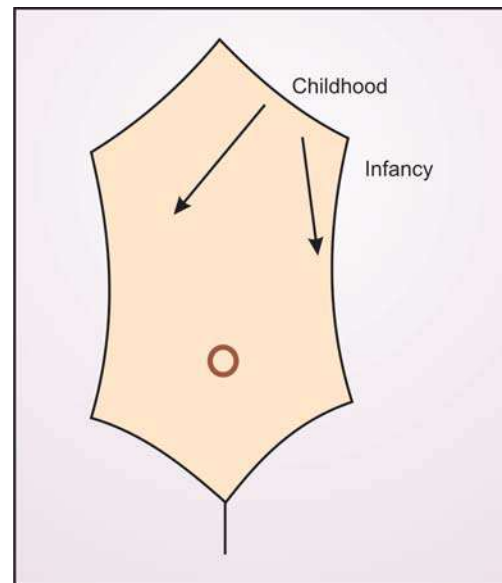

Fig. 1.4: Direction of splenic enlargement. Just palpable spleen is a normal finding in 35% term infants, 10% infants at 1 year and in an occasional child thereafter

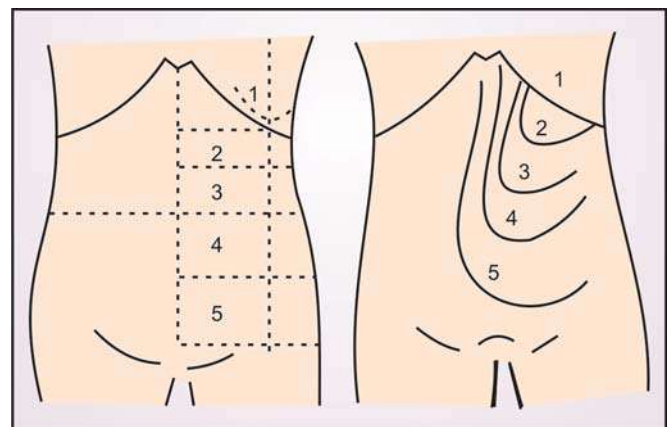

Fig. 1.5: Grading of splenic size

In case of female genitalia, examine the urethral opening, vagina, hypertrophy of clitoris, and labia minora and majora. Avoid digital or speculum examination.

Rectal Examination

Note any anal fissure, polyp, prolapse, or perianal erythema. Rectal examination should be done with a little finger that is gloved and lubricated with petroleum jelly. Once the finger is in, you may assess the anal muscle tone. Note if the rectum is empty or full. The glove should be examined for feces, mucus and blood after the finger is withdrawn.

1 Limbs and Feet

These should be examined for any deformity, asymmetry, hemihypertrophy, bow legs, knock-knees, edema (Fig. 1.6), any swelling or limitation of movements of the joints, etc. Do count the digits and the number of fingers and toes. Also, look for incurving of the little finger, syndactyly, simian crease, platynychia or koilonychia, clubbing (Box 1.7, Fig. 1.7), and presence, absence or diminution of arterial pulses. It is absolutely within normal limits for many infants to have flat feet and bow legs.

Spine and Back

Look for scoliosis, kyphosis, lordosis, dimples, sinuses, spina bifida, tufts of hair, stiffness of neck and back, any swelling, mongolian spots or tenderness. It is helpful to watch child's gait. Remember that lumbar lordosis together with potbelly may well be a normal observation in the second year of life.

Neurologic Examination

CNS examination of an infant or a young child frequently poses difficulties. This is particularly true in case of sensory examination. Table 1.4 summarizes the special features of CNS examination of infants and children.

Evaluation of cerebral function, cranial nerves (Table 1.5) and their integrity, cerebellar function, motor system meningeal signs (Fig. 1.8) and involuntary movements should be done as and when



Fig. 1.6: Pitting edema: For its demonstration in a child, the examiner needs to put more pressure with the index finger than in adults, especially in doubtful cases

indicated. In the case of a newborn, it is important to assess the primitive reflexes (Chapter 33). An estimate about the developmental and mental age should be made (Chapters 3 and 19).

Box 1.7: Clubbing

Definition: Loss of natural angle between the nail plate and nailbed with boggy fluctuation of the nailbed.

Grading

Grade 1: Increased boggy fluctuation of the nailbed.

Grade 2: Obliteration of the natural angle between the nailbed and the nail plate.

Grade 3: Increase in curvature and thickness of the nail plate from above downward and from side to side. Altered prostaglandin metabolism and proliferation of the connective tissue.

Causes

Pulmonary Bronchiectasis, empyema, lung abscess, progressive pulmonary tuberculosis, cystic fibrosis, etc.
Cardiovascular Infective endocarditis, cyanotic CUD, etc.

Gastrointestinal Malabsorption states, ulcerative colitis, Crohn disease, multiple polyposis.

Hepatic Biliary cirrhosis, chronic active hepatitis.

Miscellaneous Congenital, familial, thyrotoxicosis, Hodgkin lymphoma, syringomyelia.

Clinical Elicitation in Doubtful Cases

- Depth at the base of the nail equal or greater than the depth at the distal interphalangeal joint.
- Disappearance of the normal "window" when two fingers are approximated (see Fig. 1.7).
- When the nail is rocked on its bed with examiner's index finger and thumb, it appears to be floating.

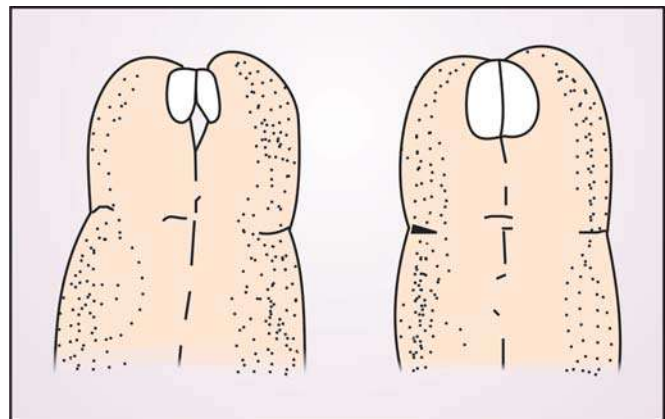

Fig. 1.7: Clubbing: Note the normal "window" (left) disappearing in case of clubbing because of the increased amount of soft tissue under the base of the nails (right). The so-called "diamond sign" or "Schromoth sign" is quite sensitive for even slight clubbing. Clubbing can also be elicited by rocking the nail on its bed between your finger and thumb. It seems to float

Table 1.4: Special features of neurologic examination of infants and children

- A considerable information can be obtained by carefully watching and interacting with the child during history taking and while he is moving about or playing.
- The sense of touch or pain should be tested during rest of the examination or during play. "Let's play... Close your eyes and say 'yes' when you feel the touch," should be the examiner's approach. Avoiding testing for pain without first preparing the child for it.
- Muscle tone is well tested by lifting the child by the shoulders. A child with generalized hypotonia simply slips out of the hands. Second useful test is that such a child's elbows are able to cross midline of the chest easily (*scarf sign*).
- The signs of meningeal irritation may be absent in certain situations, say infancy, gross malnutrition, toxemia and septicemia
- It is usual for the tendon reflexes to be exaggerated (brisk) in young children.
- Primitive plantar reflex may normally persist well upto 1 year. Its prolonged persistence, say beyond 2 years, must be considered abnormal.
- A positive Macewen sign (cracked pot sign) in first 3 years of life may well be normal.
- As a rule, optic disc on fundoscopy appears rather pale even in normal children. Ignoring this fact may lead to overdiagnosis of optic atrophy.

Table 1.5: Pediatric testing of cranial nerves

- *First (Olfactory nerve)* Ask the child to close eyes. Find out the odors (say peppermint, orange, lemon, coffee or tea) he is familiar with. Then test for them.
- *Second (Optic nerve)* Test vision and do fundoscopy to watch the optic disc.
- *Third (Oculomotor nerve)* Ask the child to follow a bright object or light in all directions without rotating the head. Watch any limitation. Also watch for size of the pupil.
- *Fourth (Trochlear nerve)* Watch for downward movement of the eye in particular which is impaired in its involvement. Even at rest, the eye tends to move upward
- *Fifth (Trigeminal nerve)* Test sensation over forehead, cheek and lower jaw. Also, test for corneal reflex and jaw jerk.
- *Sixth (Abducent nerve)* Test for lateral movements of the eye. In its involvement, the child fails to move his laterally (temporally). At rest too, such an eye has tendency to move medially (nasally).
- *Seventh (Facial nerve)* Test for asymmetry of the face when child is asked to smile or laugh, show teeth, close the eyes and attempt wrinkling the forehead. Whistling too fails in its paralysis. In case of upper motor neurone lesion (supranuclear paralysis), forehead involvement is not elicited.

Contd...

Contd...

- *Eighth (Vestibulocochlear nerve)* For auditory component, test for deafness or ringing in ears. For vestibular component, test for positional nystagmus.
- *Ninth (Glossopharyngeal nerve)* Test for gag reflex on touching child's posterior pharynx with a tongue depressor.
- *Tenth (Vagus nerve)* Examine throat for position of uvula. The normal midline uvula turns to the healthy side in case of unilateral involvement
- *Eleventh (Spinal accessory nerve)* Ask the child to shrug shoulders which showing drooping in its involvement. Moreover, he fails to move head away from the affected side.
- *Twelfth (Hypoglossal nerve)* Ask the child to show the tongue which is deviated to the involved side. The speech of the child too becomes thick.

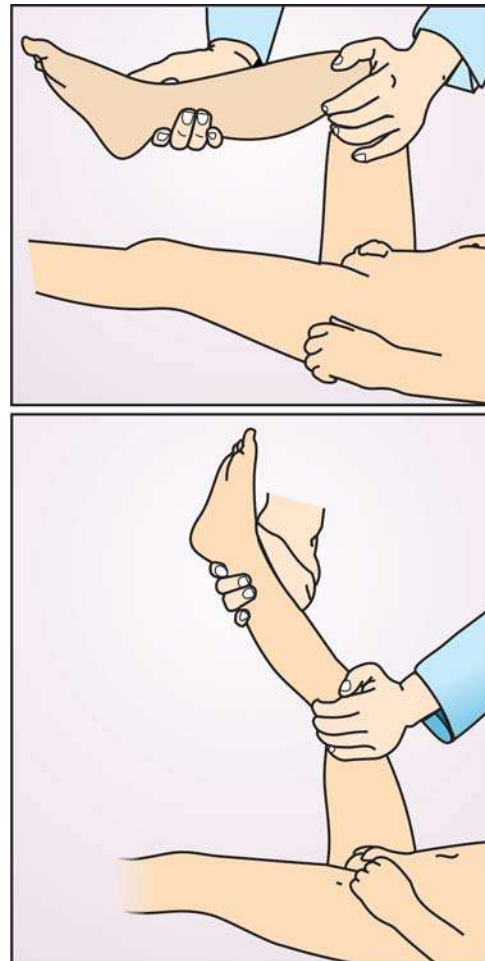

Fig. 1.8: Kernig sign. The hip and knee are flexed to a right angle. Then, the leg is gradually extended. Tightness of the hamstring and pain limitation of movements indicate a positive sign. Reciprocal flexion of the contralateral knee during this maneuver indicates a positive Brudzinski sign

A SAMPLE (MODEL) PEDIATRIC CASE SHEET

Child's Name, Age and Sex, Reg. No., Father's Name and Occupation

Full Address

Date of Admission

Date of Discharge

Provisional Clinical Impression

Final Diagnosis

Suggested Follow-up

Any Other Remarks

Informant and His/Her reliability

CHIEF COMPLAINTS (*in chronological order*)

HISTORY OF PRESENT ILLNESS

HISTORY OF PAST ILLNESSES BIRTH HISTORY

Antenatal

Natal

Postnatal

SALIENT DEVELOPMENTAL MILESTONES

Social smile	Sitting	Standing	Teething
Head-holding	Crawling	Walking	Speech

IMMUNIZATION STATUS

BCG

Oral Polio

Hepatitis B

Hib

Triple (DTP)

Measles

MMR

Typhoid

Additional (other) vaccines

Hepatitis A

Chickenpox

When were "primary" and "booster" /recall/ repeat doses given? If not given, why?

DIETETIC HISTORY

Give rough estimate of "intake" "before" and "during" illness as well. Comment on adequacy.

PERSONAL HISTORY

FAMILY HISTORY

SOCIOECONOMIC STATUS

PHYSICAL EXAMINATION*General Remarks (*appearance*, etc.)

Weight (—%) Height/Length (—%) Head circ.

Midarm circ. (—%) Chest circ.

Muscle status skinfold

Anterior fontanel Dermatitis

Pallor Cyanosis jaundice

Whether feverish

Pulse/heart rate Respiratory rate

Clubbing Lymphadenopathy

Koilonychia/platenychia Any other finding

Edema/puffiness

Any vitamin deficiency signs

SYSTEMIC EXAMINATION

Respiratory system

Cardiovascular system

Abdomen

CNS

Musculoskeletal system

ENT

Eyes

SUMMARY OF THE CASE

Provisional clinical diagnosis.

DISCUSSION

(Please give important points in support of your clinical impression. Also comment on the differential diagnosis).

INVESTIGATIONS (You would like to do)**PROGRESS NOTES**

(Brief record of investigations done, treatment given from time to time and patient's progress in the hospital)

FURTHER READING

1. Gupte S. *Differential Diagnosis in Pediatrics*, 5th edn Nw Delhi: Jaypee 2008.
2. Gill D, O'Brien N. *Pediatric Clinical Examination*. London: Churchill Livingstone, 1988.
3. Stones. *Pediatric Check-up*, 4th edn. London: Smith and Smith 2006.

* Physical examination of a child is from "region to region". The examiner must first develop a friendly rapport with him. Examination which is likely to be "irritating" should be done towards the end. Furthermore, it is of distinct value to highlight the positive findings and put question mark (?) against the doubtful findings which may well be crosschecked later.

CHAPTER



Pediatrics in the Developing World

Suraj Gupte

CONTEMPORARY PEDIATRICS

Definition and Origin

By modern definition, “pediatrics is the study of the child from the very conception through childhood, including adolescence.”

In other words, *pediatrics* is the medical science (the science of right living), which enables an anticipated newborn to grow into a healthy adult, useful to the society.

The term, *pediatrics*, is derived from the Greek words “*pedia*” (meaning a child or pertaining to a child), “*iatrike*” (meaning treatment) and “*ics*” (meaning a branch of science). As already pointed out, the contemporary understanding of this Greek term is: “science of child care, preventive as well as curative”.

Pediatrics, therefore, is concerned with the health of infants, children and adolescents, their growth and development, and their attaining full potential as adults. A pediatrician’s responsibility is not only to care for the physical, mental and emotional health from conception to maturity but also to demonstrate concern for the social, environmental and cultural influences that are known to have considerable fallout on children and their families.

Among the factors that have a bearing on health problems of children rank climate, environment and geography, prevalence and ecology of infectious agents and their hosts, agricultural resources and practices, education, economic, social and cultural considerations, stage of urbanization and industrialization, and gene frequencies.

In United States of America, pediatrics includes individuals up to the age of 21 years. UNICEF is

contented with “up to 18 years” as the pediatric age group. According to the Indian Academy of Pediatrics (IAP), health problems of children up to 18 years (inclusive) should be the responsibility of pediatricians

An Independent and Unique Speciality

There are quite a few logics for regarding *pediatrics* as an independent medical speciality? First, the health problems of children differ from those of adults in many a way. Secondly, children’s response to an illness is influenced by age. Thirdly, management of childhood illness is significantly at variance with that of an adult. Finally, children also need special care since they are among the most vulnerable in the society.

This modern concept of *pediatrics* lends it a unique status. Unlike other specialities, it deals with the excitingly dynamic process of continuous care of the growing child, *nay the whole child*. The semantic “whole child”, according to UNICEF, means that assistance for meeting the needs of children should no longer be restricted only to nutrition which is of immediate benefit to them. Instead, it should be broad based and geared to their long-term personal development and to the development of the countries in which they live. This approach is called “country health programming”. The differences between a child and an adult are appropriately concised in the saying “the child is not a little man”.

CHANGING PEDIATRIC SCENARIO

Pediatrics took birth over a century back in the prosperous countries of the West. It is, however, too much young in India and other countries of the Third

World. Over one-half of the world's total children (1.25 billion out of 2.5 billion) live in these developing regions. In India, for instance, over 40% of the one billion and odd population is constituted by the most vulnerable segment i.e. infants and children (Table 2.1). The corresponding figure for the well-developed countries is considerably low.

Table 2.1: Proportion of different age groups of children in relation to total population

Countries	0 to 14 years	0 to 4 years	5 to 9 years	10 to 14 years
India	40%	15%	13%	12%
Sri Lanka	41%	14%	14%	13%
Nepal	40%	12%	14%	15%
Pakistan	43%	16%	16%	11%
USA	27%	8%	9%	10%

A high proportion of the total morbidity and mortality in developing countries, such as ours, is still accounted by the pediatric age group.

Apparently, appreciation of the significance of child care here has come rather late. Let us hope it is not too late! In India, for example, our achievements in child health and care are a cocktail of success (e.g. total eradication of smallpox, near eradication of poliomyelitis, near eradication of guineaworm, oral rehydration therapy fall in incidence of serious forms of tuberculosis as also mortality from tuberculosis, 5 fold hike in school enrolment of girls since independence) and failure. Persistence of high incidence of tuberculosis, yet-high perinatal mortality, neonatal mortality and infant mortality, inadequate availability of safe drinking water, insufficient sewage disposal, a very high dropout in schools especially in case of girls), at least since we won our freedom over half a century back. Likewise, pediatrics which was by and large a scratch in 1947, has come a long way. Yet, the progress has fallen short of what should have been attained.

A large chunk of pediatricians (90%) in the Indian subcontinent (perhaps in most developing countries) are generalist though many of them have an area or two of special interest. Thus, by and large, each and every pediatrician is seemingly doing everything. In institutions, growth of subspecialties such as neonatology, cardiology, nephrology, gastroenterology, hematology, neurology, endocrinology, allergy, pulmonology, etc. is beginning to be palpable.

Despite the fact that some centers have started these subspecialties, their growth remains quite slow, except for, perhaps, neonatology. More recently, voice has been raised to develop pediatric subspecialty divisions in all medical colleges. It has been argued that denial of a subspecialty care to children has no justification whatsoever.

At the same time, it is felt that a spirit of partnership and shared responsibility should be developed between the limited number of pediatric subspecialists and the general pediatricians and the physicians who still continue to offer pediatric care as well. In this context, the initiative of the Indian Academy of Pediatrics (IAP) to ask its subspecialty chapters to prepare guidelines for management of common pediatric problems which can be put on Internet and linked to the IAP Website is indeed commendable. There is a need for affiliation of the IAP subspecialty chapters with the subspecialty international associations. Hopefully, this development would contribute to the development of the subspecialties at an international level.

Adolescent medicine, though fairly well-established in the West, is yet at a conceptual stage in India and other developing countries. The Indian Academy of Pediatrics (IAP) has advocated that pediatric care be extended upto (and including) 18 years age. As a matter of fact, a commendable beginning was made in India with the declaration of the year 2000 as the *IAP Year for the Adolescence and Child at Risk*. The child at risk refers to orphans, destitute, street, physically and mentally challenged children, child labor, so on and so forth. Subsequently, every year we observe *IAP Child and Adolescent Health Care Week* in November ensuring that 14 November essentially falls within it.

The collaboration from the international agencies like WHO and UNICEF and NGOs like CRY, in addition to the Union and State Governments continues to be absolutely a must for success of the strategy.

TROPICAL PEDIATRICS: NEW DEFINITION

Literally, the term, *tropical pediatrics*, denotes care of children in the tropical countries, i.e. countries occupying the region between tropic of Cancer and tropic of Capricorn. With the exception of Australia

and Singapore, all these countries are disadvantaged on account of economical deprivation. In majority of these countries, the per capita income is under US\$775. High infant mortality and under-5 mortality rates are common denominators; so are the parasitic diseases. Despite tropical environmental factors, Malaysia and Sri Lanka are successfully catching up with an infant mortality rate of 10 and under-5 mortality rate of 11/1000 live-births.

The so-called tropical diseases are no longer restricted to the tropics only. Factors such as globalization and shrinkage of the world with a free exchange of vectors and microorganisms have spread them to the nontropical countries such as those of Europe and America with special involvement of the underprivileged. Afghanistan is a glaring example of a country outside the tropics hit by the tropical diseases as a result of two decades of civil war. Its infant mortality is as high as 175/1000 live-births.

Thus, more crucial than the tropical environment in development of tropical diseases is the economy and living standard of the community. For this reason, we need to redefine the term, tropical pediatrics, as “care of children of the economically disadvantaged communities, not only in the tropical countries but also in the nontropical countries.”

RIGHTS OF THE CHILD: YESTERDAY, TODAY AND TOMORROW

The *United Nations' Declaration of the Rights of the Child* as far back as in 1959 (Table 2.2), to which India is a signatory, gives the child pride of place, as also makes the people aware of his needs and rights and their duties towards him. A nongovernmental organization (NGO), *Defence for Children International*, Geneva, has been in operation since 1979 to ensure ongoing, systemic international action, especially directed towards promoting and protecting the Rights of the Child. November 14 is observed as *Universal Children's Day* ever since 1954. The United Nations has assigned the responsibility to promote this annual day to the United Nations International Children's Emergency Fund (UNICEF).

In India's Constitution, Article 24 prohibits employment of children below the age of 14 years in factories. Article 24 prevents abuse of children of tender age. In Article 45 are incorporated provision of

Table 2.2: Ten basic rights of children as per United Nations' Declaration of 1959

- The child shall be brought up in a spirit of understanding, friendship, peace and universal brotherhood and shall not be exposed to racial, religious or other forms of discrimination.
- The child shall be protected against all forms of neglect, cruelty, exploitation and traffic and shall not be permitted to be employed before an appropriate minimum age.
- The child shall, in all circumstances, be among the first to receive protection and relief.
- The child entitled to free and compulsory elementary education and such an education as is in his best interests for which the parents are to be responsible.
- The child is entitled to grow up in an atmosphere of affection and moral and material security, with public authorities taking care of children without families or other support.
- The physically, mentally or socially handicapped child shall be entitled for special treatment, education and appropriate care.
- The child shall have the right to adequate nutrition, housing, recreation and medical services, including special health care and protection and postnatal care for the mother.
- The child shall be entitled to a name and a nationality.
- The child shall enjoy special protection to be able to develop in every way in conditions of freedom and dignity.
- All children—irrespective of their race, color, sex or creed of their parents—shall be entitled to these rights.

free and compulsory education for all children until they complete the age of 14 years.

Since 1989, the realization that children have special needs and hence the special rights has given birth to an international law in the shape of *Convention on the Rights of the Child* (CRC). The provisions of the Convention were confirmed in 1990 by the World Summit for Children. Now, the Convention is credited as the most widely ratified human rights treaty in the world.

Empowered with 54 Articles, the Convention defines children as people below the age 18 years (Article 1) whose “best interests” must be taken into account in all situations (Article 3). It protects children's right to survive and develop (Article 6) to their full potential, and among its provisions are those affirming children's right to the highest attainable standard of health care (Article 24), and to express views (Article 12) and receive information (Article 13). According to article 28, the states are obliged to make primary education compulsory and available to all

1 children. Children have a right to be registered immediately after birth and to have name and nationality (Article 31) and to protection from all forms of exploitation and sexual abuse (Article 34).

Among the large number of countries that have adopted comprehensive child rights legislation in their children's act following the birth of the "Convention" rank as small a country as Nepal.

Mercifully, notable advances have been made during the last decade of the 20th century and the subsequent years of the present, i.e. 21st century for the welfare of children, including laws to safeguard them from suffering and exploitation, near eradication of poliomyelitis, reduction of morbidity and mortality from neonatal tetanus and measles, fall in vitamin A deficiency (VAD) blindness, reduction in deaths from diarrheal dehydration, sensitization of people against child labor and child abuse and neglect (CAN), etc. As we begin the new millennium, more children are born healthy and more are immunized, more can read and write, more are free to learn, play and simply live as children than would have been thought possible even a short decade ago, according to a UNICEF report. This is the direct result of translation of the commitments made in the Convention into concrete action.

Yet, for all the gains made, violations of children's rights, particularly in the developing world, continue to be breathtaking, ranging from failure to register births and provide healthcare and education (Fig. 2.1) to exploitation in the form of child labor, abuse and neglect, and involvement of adolescents in terrorist and militancy-related armed conflicts.

As aptly put by the UNICEF, every day that nations fail to meet their moral and legal obligations to realize the rights of children, 30,500 boys and girls under 5 years die of primarily preventable diseases. Every month that the full-scale campaign needed to stop the HIV/AIDS pandemics is postponed, 250,000 children and young people become infected with the fatal virus. Every year that governments fail to spend for the basic social services or slash developmental assistance, millions of children across the developing world stand deprived of access to safe drinking water and sanitation facilities as also health and school services that are vital for their survival and growth and development.

Undoubtedly, there is a strong case for a social movement to fan the flame that burned over a decade



Fig. 2.1: Despite strides in the field of literacy globally, 130 million (21%) primary school age children in the developing world do not attend school out of a total of 625 million children of this age group in these countries. The scenario in India is no better

ago for rights of the child and the adolescent for smooth navigation into adulthood. This is particularly a "must" for advancing human development in the developing countries. And, those of us responsible for health and care of children and adolescents must in particular take it as a call for vision and leadership to realize a new dream of humankind, free from poverty, disease and discrimination.

It is pertinent to recall the historic General Assembly Special session on Children, held in 2002 to which, for the first time a large number of children were included as official members of the delegations. True to the spirit of the Convention on the Rights of the Child, the Assembly gave a call for considering the views of children and young people when decisions that affect their lives are being made.

CONTEMPORARY DISEASE PATTERN AND CHANGING CONCERNS

Figure 2.2 provides some idea about the distribution of disease pattern amongst under 5s in the developing countries. Every year, 70% of deaths in children are due to respiratory infections, diarrheas, measles, malaria or malnutrition. Figure 2.3 gives rough idea about the disease pattern in patients admitted to our pediatric indoors. With some variations, which are bound to be there from region to region, observations from various parts of India indicate a remarkably

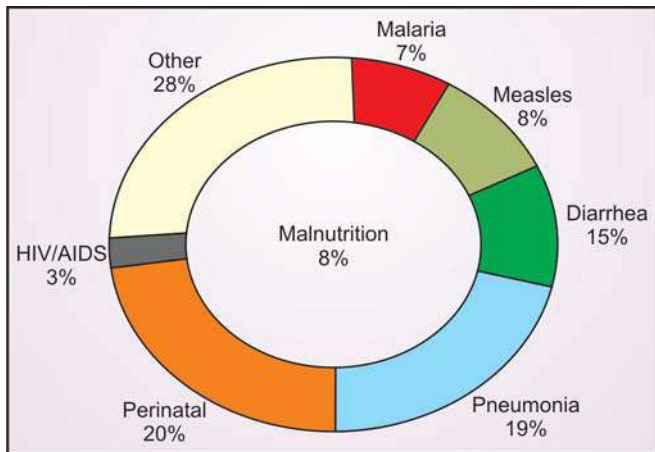

Fig. 2.2: Distribution of disease pattern in developed world in the under-5 populations

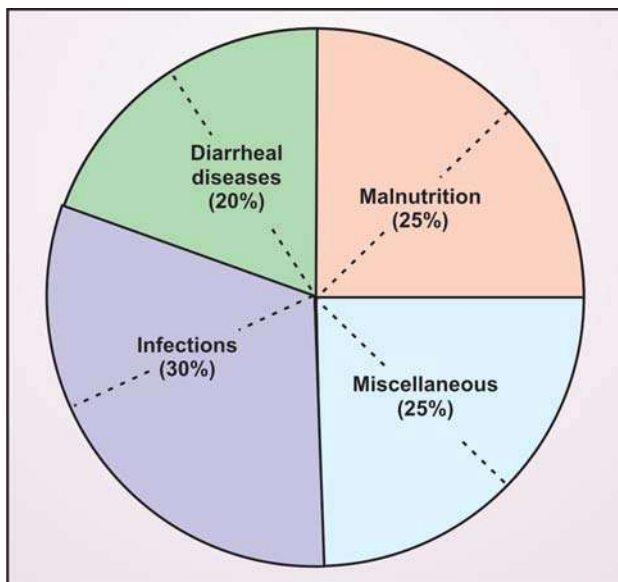

Fig. 2.3: Relative frequency of diseases responsible for admission of infants and children in Indian hospitals. Dotted lines indicate much overlap

similar pattern. This is true of some of our neighboring countries like Bangladesh, Bhutan, Myanmar, Pakistan, Afghanistan, Sri Lanka, Malaysia, Indonesia and Nepal as well.

An appraisal of the health statistics makes it clear that the scene is dominated by malnutrition (primarily the *so-called protein-energy malnutrition*), serious systemic infections (primarily tuberculosis, pneumonias, measles, whooping cough) and diarrheal disease. These have a considerable overlap on each other and, in broad sense, account for 75% of the cases. The remaining of the so many diseases are responsible for mere 25% of the admissions.

Nutritional deficiency states constitute a major public health problem in India and other countries of developing world.

Though incidence of severe malnutrition in the form of kwashiorkor and marasmus has considerably fallen, mild to moderate malnutrition continues to be a cause of concern. According to the National Family Health Survey-3, nearly one-half of the under-5s are stunted whereas around 43% are underweight, the major brunt being borne by the rural children. Over and above this, there is high incidence of micronutrient deficiencies (the so-called "hidden hunger"), particularly in relation to iron, vitamin A, iodine, zinc, etc.

Paradoxically, whereas endeavors are focused on controlling undernutrition, children from affluent families are beginning to suffer from overweight and obesity in a big way. India, therefore, appears to be in the thick of what may be termed "dual nutrition burden".

Infections are another major cause of pediatric morbidity. With considerable reduction in prevalence of preventable childhood infectious diseases, the dominance is now taken over by respiratory and gastrointestinal infections. Acute respiratory infections (ARIs) are responsible for 20 to 60% of OPD attendance, 12 to 45% of admissions and 33% of mortality in the developing world, directly or indirectly. Over 15 to 20% of preschool mortality is related to ARI.

Diarrheal diseases constitute yet another leading cause of morbidity and mortality. Almost 500 million children suffer from acute diarrhea annually. Of them, 5 million die every year. In India alone, nearly 1.5 million children become a casualty due to acute diarrhea every year.

As is obvious, the book picture of a disease is less likely to be seen in our practice and circumstances. A 6-year-old, presenting with acute dysentery, may have significant malnutrition also. To cap this, he may have pulmonary tuberculosis. That is not the end, however. Such a child, as we have often seen, may have one or more intestinal parasitic infestations and skin infections like scabies and pyoderma.

Thus, one finds a multiplicity of ailments in a single child. This kind of a patient has been compared to a *camel-back*. The observation has been made by us and by others in this country and other developing countries where people continue to be underprivileged. This consideration, in particular, has contributed to the launching of the latest health

strategy for children by the World Health Organization (WHO) and UNICEF. Christened *Integrated Management of Childhood Illness (IMCI) Scheme*, the program has yielded excellent results in Africa and certain other developing countries. It is likely to assume the status of a dominant child health and welfare program in India. A brief deliberation on the strategy is presented in Chapter 6.

What is particularly disappointing in relation to the developing world is that even as we are in the second half of the first decade of the 21st Century, illiteracy, ignorance, superstitions, cultural and religious practices and rituals continue to have considerable influence in the area of health and nutrition. Howsoever incredible it may seem, diseases are still thought to be caused by witchcraft and quite a proportion of people rely on medicine for their treatment also. In a pilot study, we found that 40% of the slum parents believed that "disease can be caused by the wrath of deities (supernatural beings), a posthumous world of dead ancestors and magical concepts."

Mercifully, there is a greater appreciation of the emergence of such newly recognized problems as HIV/AIDS, drug abuse among teenagers, child abuse and neglect, street children, child labor, discrimination against girl child, emerging and reemerging infections, etc. and need to meet this challenge. HIV/AIDS alone appears to be threatening to nullify all benefits from national health programs aimed at welfare of children.

The aforesaid disease pattern contrasts with that prevalent in the prosperous countries where accidents (including poisoning), neoplasms, obesity (not under-nutrition), HIV/AIDS, etc. overshadow the scene.

No doubt, climatic, geographical and ethnic factors play some role for this remarkable difference. But, of much greater significance are factors like socioeconomic conditions, hygiene and sanitation, culture, education and local medical and health facilities.

Interestingly, today's pediatric disease and mortality pattern in the poor and the underprivileged was observed in the European countries many decades ago when their socioeconomic structure was far from satisfactory. Furthermore, even now certain not so well-to-do temperate regions (say some parts of Chile's countryside) and certain present day European races (say Eskimos and Laplanders of Scandinavia) show

patterns somewhat comparable to ours. This, in a way, speaks against the usual concept of *tropical pediatrics*. Today, the term should be clearly appreciated as to have little to do with the climate or geography. Of course, a few conditions, like prickly heat, frunculosis and fungus infection of the skin, are influenced by heat, humidity and dryness of the tropics and subtropics. Also, the Indian childhood cirrhosis, kala-azar, trypanosomiasis, Burkitt's lymphoma, etc. may well be special local problems. At best, climate may have some contributory influence.

With passage of time, major changes in priorities and relative importance of various causes of morbidity and mortality are expected. Eradication of smallpox, remarkable reduction in incidence of such infectious diseases of childhood as poliomyelitis, and emergence of AIDS in recent years illustrate this point. Undoubtedly, priorities must reflect local concerns, resources and requirements to be of real value to the community.

MORTALITY SCENARIO AND DELIVERY OF CHILD HEALTH CARE

Table 2.3 gives salient mortality data in India.

The vital statistics are quite telling indeed. Today, a child in India has far better chances of survival, with the life expectancy being about 65 years, than three decades back though the situation is still far from satisfactory. The *current infant mortality rate of 55 per 1,000 live-births* (from 129 in 1970) is still many times higher than in the advanced countries. Vast statewide variations are noteworthy with Kerala having IMR of 13 and Orissa 93. Likewise, urban India has much lower IMR compared to rural India.

Perinatal mortality (a reliable index of status of women and their health and the quality of antenatal, natal and neonatal care) of 39/1000 live-births in India is far higher than 10 to 20 in most developed countries. It is estimated that 3 perinates die in India every minute amounting to a colossal human wastage of 1.5 million perinates every year. Likewise neonatal

Table 2.3: Broad mortality data in India

50% of all deaths occur below 5 years
33% of all deaths occur below 1 year
20% of all deaths occur below 1 month
10% of all deaths occur below 1 week

mortality is 40/1000 live births compared to a figure of 1 to 4 in developing countries. About 60% of the infant mortality is accounted by neonatal deaths.

Factors responsible for continued high perinatal/neonatal mortality (30/1000 live births) include vicious cycle of frequent pregnancies, compromised maternal health and nutrition, high incidence of low birthweight and, in consequence, poor perinatal survival. Perinatal care is either not available or is very unsatisfactory. When available, it is availed of only by a small proportion of the mothers because of illiteracy, ignorance and cultural and social bias.

It is now widely accepted that significant gains as far as IMR are concerned are due to fall in postneonatal deaths as a result of availability of ICDS scheme, UIP, ARI, vitamin A prophylaxis programs, etc. Since perinatal mortality, accounting for 60% of the IMR, remains only marginally altered, it has become increasingly difficult to remove stagnation in the IMR (at present 55). This factor apparently contributed to India's failure to meet the deadline of reducing the IMR to under 60/1000, perinatal mortality to 30 to 35/1000 and incidence of low birthweight infants to 10% from 30% by the turn of the 20th century.

Let us have a peep into the real cause. Whereas in advanced countries 5 to 12% of the Gross National Product (GNP) is reserved for health services, only 2% of India's GNP is allocated for this vital area. Maternal and neonatal care, though well accepted, is further neglected. With the exception of tetanus toxoid prophylaxis, iron-folate tablets, and somewhat lopsided training of the traditional birth attendants (TBAs), no concrete program was indeed available for neonates and pregnant women until recent past.

A survey conducted in 1976 by us showed that "93% of the teaching institutes in India are not adequately equipped with neonatal care facilities". A follow-up survey in 1985 and yet another in 1992-93 showed only marginal improvement in the state of affairs. Another survey conducted by the National Neonatology Forum points out that almost 3/4th of the hospitals are not equipped with even the basic tools of neonatal care, like low-reading rectal thermometers, oxygen head boxes, resuscitation equipment, exchange transfusion sets and incubator/open care system. The neonate is regarded as only a byproduct of conception. He is seldom entitled to a status of a bed in the ward. According to the preliminary results of our most recent survey, well meaning child-friendly developments

over the last decade or so are beginning to transform the pediatric scenario in the country to one of expectancy.

According to one estimate, chances of a newborn attaining the age of 5 years in India are the same as reaching the age of 50 or 60 years in the prosperous countries. The preschoolers form about 17% of the population but are responsible for over 40% of the total mortality. Notwithstanding the developments of the past decade, under-5 mortality, infant mortality, neonatal mortality and perinatal mortality rates are still unacceptably high. Notably, mortality rates in rural and periurban areas are nearly double those in urban areas (Tables 2.4 and 2.5).

Table 2.4: Under-5 mortality rate (U5 MR), infant mortality rate (IMR) and neonatal mortality rate (NMR) in India and some other developing and affluent countries

Countries	U5-MR (2006)	IMR (2006)	NMR (2000)	Countries	U5-MR (2006)	IMR (2006)	NMR (2000)
India	76	57	43	Mauritius	14	13	12
Indonesia	34	26	18	Malaysia	12	10	5
Pakistan	97	78	57	Singapore	3	2	1
Bangladesh	69	52	36	Australia	6	5	3
Nepal	59	46	40	Japan	4	3	2
Bhutan	70	63	38	Philippines	32	24	15
Myanmar (Burma)	104	74	40	Thailand	8	7	13
China	24	20	21	Turkey	26	24	22
Afghanistan	257	165	60	USA	8	6	5
Iran	34	30	22	UK	6	5	4
Iraq	46	37	63	Sweden	3	3	2
Egypt	35	29	21	Canada	6	5	4
Saudi Arabia	25	21	12	France	4	4	3
Sri Lanka	13	11	11	Switzerland	5	4	3

Table 2.5: Proportion of children dying before the fifth birthday

Countries	Percentage	Age (year) at which this happens in USA
India	28.1	63
Pakistan	31.0	66
Egypt	24.8	61
New Guinea	36.7	68

On the morbidity front, despite improvement in the vital pediatric statistics, quality of life is generally not up to the mark. Almost 1/3 rd of the pediatric population has a deplorable existence. About 3/4th of our pediatric population can be classified as **unhealthy** and surviving with impaired bodies and intellects (Figs 2.4 to 2.6). Various interrelated conditions such as malnutrition, diarrheal disease,



Fig. 2.4



Fig. 2.5

infections like tuberculosis, ARI, parasitic infestations, etc. contribute to ill health and poor growth. Over 50% of children are undernourished. The most vulnerable period for malnutrition is first 3 years (usually 6 months to 2 years) of life. The consequences of too



Figs 2.4 to 2.6: What does future hold for them? The majority of the children in the developing countries barely manage to survive. Any realistic health strategy must make “them” a priority for action

many mouths-to-feed and the lack of fool-proof system of health care with an accent on the rural and the urban poor and other social services against a backdrop of generally poor socioeconomic status further aggravate the situation.

Logically, therefore, the solution lies in the health services going to them rather than other way around. No wonder that this also requires active participation of the communities which should learn to protect themselves from disease and seek help as and when they need it. There is also need to increase the health budget which at present is inadequate.

Besides the failure of the health strategy, unfavorable factors like rising population, lack of resources, poverty, ignorance and illiteracy have contributed to the sad state of health of our children.

PEDIATRIC EDUCATION

Pediatric education, the art of imparting knowledge about child health, in the developing world cannot be on the same lines as in the developed world since the needs of children in the two worlds are not the same. For instance, the pediatricians in the West, face newer problems like AIDS, fetal anomalies, genetic counseling, adolescent substance abuse, obesity, etc. In the developing countries, on the other hand, the priorities are malnutrition, diarrheal disease and infections such as ARI, tuberculosis and intestinal parasitosis as also low birthweight infants. Training in pediatrics in these countries needs a relatively greater focus on clinical diagnostic skills and affordable therapies rather than on sophisticated investigations and expensive therapeutic modalities.

Now, thanks to the concerted efforts of the Indian Academy of Pediatrics (IAP), the sole representative body of India's around 16 thousand qualified pediatricians and a guardian of the speciality in the country, pediatrics now holds the status of an independent discipline, both in undergraduate medical teaching and university MBBS examinations. As a result, pediatrics is being taught to the medical students on par with adult medicine, surgery and obstetrics and gynecology. The major beneficiary, directly or indirectly, shall undoubtedly be our child population.

There is a considerable merit in the suggestion that the growth and development component of pediatrics be introduced in the preclinical years of the undergraduate career.

Today, opportunities for postgraduation are available not only in general pediatrics but also in a few of its subspecialties. It is felt that the MCI must initiate action to develop uniformly standard curriculum as also uniform system of examination in case of the pediatric postgraduates as well. The task needs to be accomplished in the beginning of the 21st century rather than allowed to catch dust for another few decades.

Box 2.1 outlines the national sociodemographic goals for 2010 as per the National Population Policy (NPP) 2000 which provides a policy framework for advancing goals and prioritizing strategies during the current decade.

Box 2.1: India's national sociodemographic goals for the decade ending 2010

1. To address the unmet needs for basic reproductive and child health services, supplies and infrastructure.
2. To make school education up to age 14 years free and compulsory and reduce dropouts at primary and secondary school levels to < 20% for both sexes.
3. To reduce infant mortality rate of < 30/1000 live births.
4. To reduce maternal mortality rate to < 100/100,000 live births.
5. To achieve universal immunization of children against all vaccine-preventable diseases.
6. To promote delayed marriage for girls, not earlier than 18 years and preferable after 20 years of age.
7. To achieve 80% institutional deliveries and 100% deliveries by trained persons.
8. To achieve universal access to information/counseling and services for fertility regulation and contraception with a wide basket of choices.
9. To achieve 100% registration of births, deaths, marriage and pregnancy.
10. To curtail spread of HIV/AIDS.
11. To prevent and control communicable diseases.
12. To integrate Indian systems of medicine (ISM) in the provision of RCH services and in reaching out to households.
13. To promote vigorously the small family norm.
14. To bring about convergence in implementation of related social sector programs so that family welfare becomes a people-centered program.

NEW CHALLENGES

Not just that! Now that the famous Barker's hypothesis linking the childhood and adult diseases to fetal, infant and childhood period appears to be holding good in entirety, there is a dire need to increase awareness about the impending explosion of epidemics of diseases such as diabetes, hypertension, coronary artery disease, metabolic syndrome etc. These diseases are being increasingly diagnosed not only in adults but also in young children and adolescents. There is a need to forewarn the community and to research and deliberate on their prevention and early diagnosis employing simple and affordable strategies.

BETTER TOMORROW

To cut the long story short, the greater attention on the "whole child"—not just the childhood ailments—can go a long way in promoting family welfare and

1 checking enormous population explosion. As soon as people are convinced that their children are going to survive and grow into healthy adults, the temptation to have too many issues will decline.

The pace of practical implementation of Government's professed policy has got to be drastically accelerated. This needs a political will and commitment rather than sheer slogans and paperwork, as also augmentation of the health budget. There is no place for lopsided priorities.

The best pediatric slogan should be: **Not many but healthy children**, if we are keen on having a happier nation.

The time to act is now. Today. Yes, right away!

For, as the poet, Gabriela Mistral, puts it: "Many of the things we need can wait. The child cannot. His name is Today. To him we cannot answer tomorrow".

Table 2.6 lists some of the significant medical advances that are likely to contribute to mitigating medical problems of children in the developing countries such as ours.

To the conservative reader, this may sound rather premature. But, mind, you, what we have in mind is the projected scenario a decade or two ahead.

Table 2.6: Important medical advances likely to mitigate medical problems of children in India and other developing countries

- Better vaccines, pharmaceuticals and diagnostics
- Food security through improved agricultural methods, therapeutic foods and alternate energy sources
- More appropriate public health policies and measures
- Magic bullet drug delivery system
- Production of artificial blood
- Computer chips with genes for mastery of the human proteome
- More application of gene therapy
- Enhanced partnership for child health

To conclude, let us modify what John Ruskin said a century ago:

"I hold it indisputable that the first duty of a State is to see to it that every child is well-housed, clothed, fed, educated and kept fit."

FURTHER READING

Articles/Chapters

1. Ghosh S. *Nutrition and Child Care: A Practical Guide*. New Delhi: Jaypee 1997.
2. Gopalan C: Child care in India: emerging challenges. *Indian Pediatr* 1993;30:593.
3. Kapil U, Singh P, Pathak P, *et al*. Prevalence of obesity amongst affluent adolescent school children in Delhi. *Indian Pediatr* 2002;39:449.
4. Prenczuk J, Bhave S. Children's health and the environment: building capacities *India Pediatr* 2007;44:253.
5. Ramachandran A, Snehlatha C, Vinutha R, *et al*. Prevalence of overweight in urban Indian adolescent children. *Diab Res Clin Pract* 2002;57:185.
6. Santos Ocampo: Tropical pediatrics 2002 to 2015. In *Proceedings of the 6th International Congress of Tropical Pediatrics*, Ankara, Turkey 2002. Ankara: International Children's Centre. 2003:1.
7. Thacker N, Vasistha VM. Global polio scenario: current status. In Gupte S (Ed): *Recent Advances in Pediatrics-13*. New Delhi: Jaypee 2003;427-435.
8. Torjesen K, Olness K. Child health in the developing world. In: Kliegman RM, Behrman RE, Jenson HB, Stanton BF (Eds): *Nelson Textbook of Pediatrics*, 18th edn. Philadelphia: Saunders 2008:12-14.
9. Verma IC: The Indian child and the new millennium: Hope or hype? *Indian J Pediatr* 2000;67:1.

Books/Monographs

1. International Institute for Population Science (IIPS)/Macro International. *National Family Health Survey (NFHS)-3, India, Vol II*. Mumbai: IIPS 2007.
2. UNICEF. *The State of the World's Children 2008* New York: UNICEF 2008.

CHAPTER



3

Growth and Development

Suraj Gupte, EM Gomez

DEFINITIONS

Growth, a measure of physical maturation, signifies an increase in size of the body and its various organs. Thus, it can be measured in terms of centimeters and kilograms.

Growth is mainly due to multiplication of cells and an increase in intracellular substance. Tissues show an increase in DNA content. During second half of pregnancy, an increase in cell size with increase in protein/DNA ratio occurs. Until 10 years of age, this increase is high but thereafter it becomes slow. Unlike in the adult, growth is an essential feature of the child's life.

Development is a measure of functional or physiological maturation and myelination of the nervous system. It signifies accomplishment of mental (acquisition of skills, etc.), emotional (development of attitudes, etc.) and social (adaptation to family and society, etc.) abilities. Unlike growth, it is rather difficult to assess development.

Growth and development are so closely interrelated that it is virtually not possible to separate one from the other. Consequently, in practice, these terms are either used together or denote synonymous meaning. Strictly speaking, they represent two different aspects: quantity (growth) and quality (development). Though the two generally proceed concurrently, this may not always be so.

GROWTH STUDIES

Growth studies are of two types:

1. *Cross-sectional*: Here each child in the large sample size is measured only once. It is less than consuming, economical and simple (i.e. easy to

conduct). However, it fails to provide growth increment/decrement ("velocity").

2. *Longitudinal*: Here a group of children are followed from a particular age (say "birth") to a particular point (say "maturity"). It is time-consuming, costly and somewhat difficult to undertake. Its major edge over cross-sectional study is that it provides the growth velocity and thereby the growth spurts.

The longitudinal study in which all participating subjects cannot be followed up over the full duration of study for logistic reasons is called "semilongitudinal" or "mixed longitudinal" study. The longitudinal study in which different observers undertake different parts of the study in a short-time interval is called "linked longitudinal" study.

VARIOUS FACTORS INFLUENCING GROWTH AND DEVELOPMENT

A number of factors influence growth and development (Fig. 3.1).

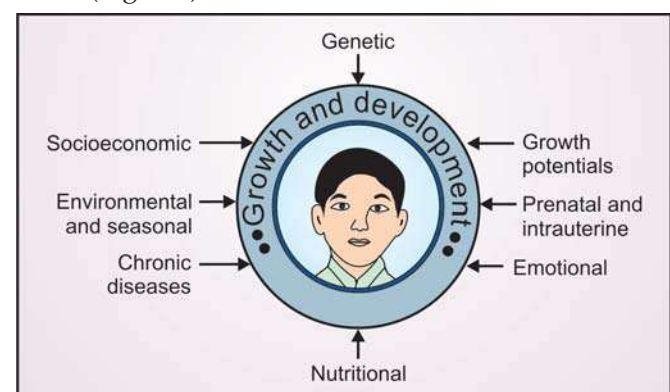

Fig. 3.1: Factors influencing growth and development

1 Genetic Factors

It is well known that certain hereditary influences may have a bearing on the ultimate constitution of the body.

- *Parental traits* Tall parents are likely to have tall offsprings. Likewise, level of intelligence of parents influences the intelligent quotient (IQ) of their children.
- *Genetic disorders/abnormal genes* Transmission of some abnormal genes may result in a familial illness which affects the physical and/or functional maturation, e.g. phenylketonuria (PKU), thalassemia, hemophilia, mucopolysaccharidosis, galactosemia, etc. In addition, many inherited disorders, where biochemical defects are yet to be identified, are accompanied by defect in growth and development.
- *Chromosomal disorders* Many chromosomal disorders, including Down syndrome, Klinefelter syndrome, Turner syndrome, etc. are known to manifest in the form of growth and developmental aberrations.
- *Race* Growth potential varies from race to race.
- *Sex* Generally speaking, at birth, boys are taller and heavier than girls. When they mature towards adulthood, average height and weight of boys score over the girls.
- *Biorhythm* Girls usually follow the same pattern of menarche and menstrual cycle as their mothers.
- *Twinning* Multiple pregnancies usually result in small babies who are likely to attain
- low height and weight in the long run.

Nutritional Factors

Nutritional deficiency of proteins, calories, minerals, vitamins, and essential amino acids (especially lysine), both quantitative and qualitative, considerably retards physical growth and development. Also, other debilitating illnesses which interfere with adequate nutrition (say, malabsorption syndrome, tuberculosis, malignancy, chronic diarrhea/dysentery, intestinal parasitic infestations) exert similar effect.

Malnourished mothers, particularly if they continue to be fed poorly during pregnancy, are known to produce low birthweight babies, especially with intrauterine growth retardation (IUGR). On the other hand, average birthweight of infants whose mothers are fed well during pregnancy is far higher.

Overnutrition, beyond a limit, may cause obesity. What a paradox that, whereas obesity is emerging as a major health hazard in the affluent countries (now in developing countries too), undernutrition has failed to demonstrate a really significant downhill course in the developing regions of the world!

It is worth mentioning that undernutrition affects the growth in weight far more than that of length/height. Nevertheless, chronic undernutrition spread over significant period leads to "stunting" (short stature).

Socioeconomic Factors

Poverty is associated with diminished and affluence with good growth. Children from well-to-do families usually are better nourished.

Environmental and Seasonal Factors

Physical surroundings (sunshine, hygiene, living standard) and psychological and social factors (relationship with family members, teachers, friends, etc.) affect growth and development. It has also been observed that maximum weight gain occurs during fall and maximum height gain during spring.

Chronic Diseases

Chronic diseases of the heart (congenital heart, chronic rheumatic heart), chest (tuberculosis, asthma, cystic fibrosis), kidneys (nephrotic syndrome, nephritis, bladder neck obstruction), liver (cirrhosis, hydatid cyst), neoplasms, digestive or absorptive disorders, hypothyroidism, hypopituitarism, etc. impair growth. Adrenocortical overactivity causes excessive height in early childhood. Metabolic disorders (glycogen-storage disease, renal acidosis) and mental retardation are associated with retarded growth. High levels of growth hormone result in gigantism.

Acute illnesses, in general, do not have any noteworthy effect on growth and development.

Growth Potentials

The smaller the child at birth (especially in context of gestation) the smaller he is likely to be in subsequent years. The larger the child at birth, the larger he is likely to be in later years. Thus, the growth potential is somewhat indicated by child's size at birth.

Prenatal and Intrauterine Factors

Intrauterine growth retardation (IUGR), endometritis, maternal infections like rubella, cytomegalic inclusion body disease and toxoplasmosis, and maternal diabetes mellitus, hypothyroidism, antithyroid drugs administered for thyrotoxicosis, etc. adversely affect the fetus and thereby the newborn.

Emotional Factors

Emotional trauma from unstable family, insecurity, sibling jealousy and rivalry, loss of parent(s), inadequate schooling, etc.—all have negative effect on growth and development.

Not infrequently, a plethora of unfavorable influences join hands to affect the growth and development adversely.

Hormonal Factors

- *Growth hormone* Whereas growth hormone is not needed for fetal growth, its role in postnatal growth is significant.
- *Thyroxine* deficiency (from maternal hypothyroidism or maternal medication with antithyroid drugs and iodides in second half of pregnancy) may cause fetal goiter and hypothyroidism with retardation of the skeletal growth of the fetus.
- *Insulin* Diabetic mothers cause increase in fetal blood sugar that leads to hyperplasia of islets of Langerhans and elevation of insulin production. This results in stimulation of fetal growth. That is why fetus is large with high birthweight in diabetic mothers. Similar influence is exerted by a polypeptide produced by placenta (the so-called “insulin-like growth factor”).

VARIOUS PERIODS OF GROWTH

Prenatal

- *Ovum* 0 to 14 days after conception.
- *Embryo* Upto 12th or 14th week. It differentiates into various structures and organs of the body.
- *Fetus* Up to birth. It is characterized by establishment of various vegetative functions.

Postnatal

- *Newborn* First 4 weeks of life. During this period, following the cutting of the umbilical cord, the

baby establishes independent respiration and circulation and makes many more adjustments, such as feeding and weight gain.

- *Infancy* First year of life.
- *Toddler* 1 to 3 years. During this stage, the baby is able to walk, assume greater independence and participate in some family activities.
- *Preschool (early childhood)* 3 to 6 years.
- *School-going (middle-childhood)* 6 to 10 years for girls and 6 to 12 years for boys.
- *Prepubescent (late childhood)* 10 to 12 years in girls and 12 to 14 years in boys.
- *Pubescent* 12 to 14 years in girls and 14 to 16 years in boys.
- *Postpubescent* 14 to 18 years in girls and 16 to 20 years in boys.

LAWS (PRINCIPLES) OF GROWTH

Order of Growth

Growth is a continuous as well as an orderly process.

As a rule, human growth is cephalo-caudal and distal-proximal. During intrauterine life, head (cephalic part), for instance, grows before neck, body and arms (caudal parts) and hands (distal part) grow before the arm (proximal part). During postnatal life, though growth of head becomes slow, extremities continue to grow fast. Head control occurs before use of hands and creeping and crawling.

Growth occurs in a *sigma fashion* with periods of accelerated growth and slow growth. Fetal growth in first half of gestation is much faster than in the second half. Postnatally, growth is accelerated in first few months of life and then at puberty.

Postnatal Growth Patterns

These are shown diagrammatically in (Fig. 3.2). As is evident, *general body growth* is compared with *genital, neural and lymphoid growth* at various ages:

General Type

It pertains to body as a whole, external dimensions (with exclusion of head and neck), respiratory and digestive organs, aorta and pulmonary trunk, kidneys, spleen, blood volume and the whole of musculature and skeleton.

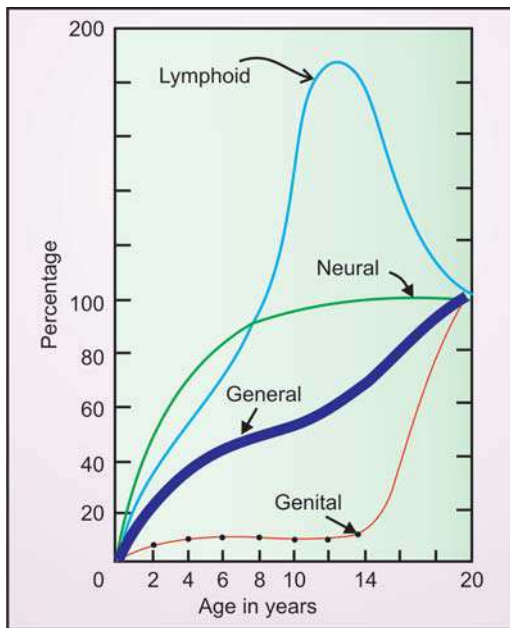

Fig. 3.2: Major types of postnatal growth curves

An appraisal of the different curves reveals that there are two periods of rapid general growth: infancy and adolescence.

Genital Type

It pertains to testis, ovary, epididymis, uterine tube, prostate, prostatic urethra, seminal vesicle. Genital growth is most rapid during adolescence; in the preceding years, it is more or less, a flat curve.

Neural Type

It pertains to brain and its parts, dura, many head dimensions, optic apparatus, spinal cord. Neural growth continues fairly rapidly during the first few years of life and then approaches the adult size. As much as 60% of total neural growth is achieved by 2 years and 90% by 6 years. The remaining 10% occurs in the rest of childhood and adolescence.

Lymphoid Type

It pertains to thymus, lymph glands, intestinal lymphoid masses.

Lymphoid growth is rapid in infancy and highly accelerated in childhood. It rapidly drops to the adult proportions during adolescence.

Variations in Body Proportions

At different ages, body growth is not uniform. As for instance, during infancy, head is much larger in relation to the size of the rest of the body. This proportion gradually changes to assume the adult ratio in the subsequent years of childhood and adolescence.

In younger children, the limbs are relatively short. The relationship of sitting height (trunk and head) with total height is a useful index in the diagnosis of certain disorders of growth. In a child with hypopituitary dwarfism, the body proportions correspond to chronological age. Body proportions in a child with hypothyroidism, on the other hand, are expected to be infantile.

Types of Body Build (Somatotypes)

According to Sheldon somatotype classification of human physique, the individuals can be categorized as ectomorphic, endomorphic or mesomorphic.

Ectomorphic Relative preponderance of linearity, light bone structure, small musculature and subcutaneous tissue in relation to body length and large surface area.

Endomorphic Relative stocky build and large amount of soft tissue.

Mesomorphic Between the ectomorphic and endomorphic. Relative preponderance of muscle, bone and connective tissue with heavy, hard physique of rectangular outline.

Growth Spurts

Acceleration of growth is characteristic of three periods (the so-called growth spurts):

- First year (infantile growth spurt)
- Six to eight years (midgrowth spurt)
- Adolescence (adolescent growth spurt).

IMPORTANT CRITERIA/ INDICES FOR ASSESSMENT OF GROWTH

Weight

On an average, ideal birthweight is said to be around 3.25 kg. The newborn loses up to 10% of his weight during the first week. It is, however, regained by the age of 10 days. After this, weight gain occurs at a

rate of 25 to 30 g a day for the first 3 months and 40 g a month during the rest of the first year of life. The infant doubles his birthweight by the age of 5 months and trebles it by one year. He increases it 4 times by 2 years, 5 times by 3 years, 6 times by 5 years and 10 times by 10 years. For convenience, you may remember:

Weight (kg) at birth = 3.25

Weight (kg) at 3 to 12 months = $\frac{\text{age (months)} + 9}{2}$

Weight (kg) at 1 to 6 years = $\text{age (years)} \times 2 + 8$

Weight (kg) at 7 to 12 years = $\frac{\text{age (years)} \times 7 - 5}{2}$

Ideally, a beam type of weighing machine (Fig. 3.3) should be used in hospital and clinic practice to record weight.

For field, an Indian modification of the famous *English Salter spring machine* (Fig. 3.4) is good enough, provided that its accuracy is checked periodically. It is portable, weighing only 2 kg, and is accurate upto 100 g. A scale accurate upto 20 kg is available. Thus, all preschool children can be weighed with the same machine.

For weighing, the child is suspended in a canvas or strong cloth holder while the machine itself is hung from a hook, a peg or the leg of an upturned string bed. Even an attendant can hold it up by hand till the weight is recorded. Time to time testing of its accuracy is vital. Ratio of total body water to body weight is a dependable measure of body fat, correlating at about 0.62 with skin-fold thickness.

Growth Chart: It is of value to have serial record of child's weight periodically on a "growth chart"



Fig. 3.3: A conventional beam balance scale for weight recording in hospital and clinic practice

("Road to Health" chart or card) which is based on percentile curves. A flat curve indicates a slowed or arrested growth which must alert the attending doctor to take action, both diagnostic as to its cause and corrective so as to lead to normal growth once again.

The WHO growth chart has the upper reference curve representing the 50th percentile (for boys) and the lower curve the 3rd percentile for girls.

The growth chart recommended by the Government of India has 4 curves; the topmost representing 80% (50th percentile), followed by 70%, 60% and 50% of the median of the WHO standard. Correspondingly mild, moderate and severe malnutrition can be detected.

The ICDS growth chart has over and above the standard, 3 reference lines

The IAP growth chart is being attached with this chapter which also incorporates immunization development and health records.

The chart is meant:

- To make growth a tangible visible attribute.
- To create a felt need, a demand for growth.
- To detect the earliest signs of faltering growth.
- To reinforce effective behavior resulting in growth.
- To illustrate the adverse effects of various negative events or circumstances on growth (infection, maternal deprivation, seasonal scarcity, etc.)
- To facilitate the transfer of information to the mother regarding means to promote growth.



Fig. 3.4: Hanging scale for weight recording in field practice

The growth chart is primarily meant for the mother, to visualize and motivate concern for healthy growth in her child. It should, therefore, be sufficiently attractive and designed to facilitate accurate recording in a simple manner and enable mothers to recognize growth faltering at the earliest stage.

Growth monitoring and promotion (GMP) is an operational strategy of regular and sequential measurements for the assessment of growth and development of the child in the community in order to promote optimal health. The strategy recognizes growth to be the result of overall health, nutrition, environment, social, psychic and developmental factors rather than sheer nutrition. It involves mothers and health workers in a meaningful and reinforcing way, aiming at action before overt malnutrition occurs. As far as possible, it should be a "mother-to-mother" strategy facilitated and assisted by the health workers. Growth monitoring is best initiated from birth rather than when the child is already 2 to 3 years old.

It has been argued that the doubts raised about the successful implementation of the GMP programs appear to be related to its faulty implementation.

Length/Height

On an average, the ideal length of a full-term infant at birth is 50 cm. It rises to 60 cm at 3 months, 70 cm at 9 months, 75 cm at one year, 90 cm at 2 years, 95 cm at 3 years and 100 cm at 4 years. Thereafter, the child gains little over 5 cm every year until 10 years. With the onset of puberty, remarkable acceleration in height gain occurs.

For convenience, you may remember:

Length (cm) at birth	50
Length/height (cm) at 1 year	75
Height (cm) at 2 to 12 years	age (years) × 6 + 77
Half of the adult height is attained by 2 years in girls and 2 ½ years in boys.	

Mid parental height (MPH) a good predictor of adult height, is calculated by the following formula:

MPH in boys =

$$\frac{\text{Fathers height} + \text{Mother's height} + 13}{2}$$

MPH in girls =

$$\frac{\text{Fathers height} + \text{Mother's height} - 13}{2}$$

For children under 2 years, it is advisable to measure the *recumbent length* while the child lies supine (with legs fully extended at hips and knees and feet at right angles to legs) in the so-called infantometer (Fig. 3.5). Such an infantometer may be fabricated by placing a book vertically at the headend and another at the footend.

In older children, *standing height* is measured by making the child stand against a vertical scale fixed on a stand or simply against a wall and then marking the highest point of the vertex on the wall, using the head piece or simply a book. Make sure that the child stands comfortably with heels, buttocks, shoulders and back of the head touching the wall and the feet parallel. Arms should hang naturally by the sides. The line joining the upper margin of the external auditory meatus and lower margin of the orbits (Frankfort horizontal plane) should be in the plane parallel to the floor. Try to use a good steel measuring tape rather than that of a tailor. Now, digital ultrasonic height measuring system too has become available.

Weight for Height

It is calculated by dividing actual weight by weight corresponding to the height and then multiplying the quotient by 100. A value below 90.5% indicates malnutrition and above 120% overweight/obesity.

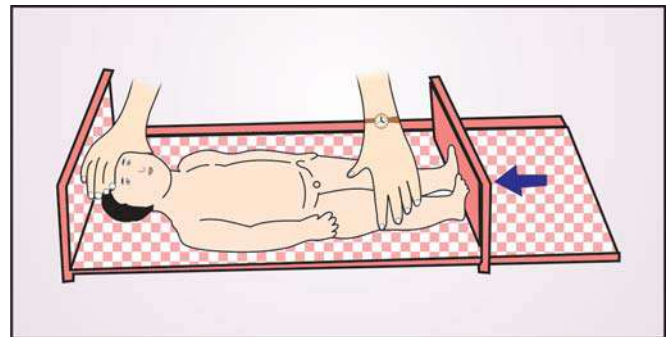

Fig. 3.5: Infantometer. In case this kind of an infantometer is not readily available, the purpose is served with a fabricated infantometer employing a book at the head-end and another at the foot-end of the infant (in lying down posture)

Growth Velocity

Growth velocity is the rate at which the child grows over a period of time. Beyond the neonatal and infancy period, rather than weight, it is the height that is more useful as an indicator of growth, especially when two measurements are recorded at an interval of about 6 months. Growth velocity oscillates around 50th centile.

For determining growth velocity (in other words, height velocity), height needs to be measured on more than one occasion over a period of time and the increment in height divided by the lapse of time in between. Thus, the formula for growth velocity (GV) turns out to be:

GV (cm) =

$$\frac{\text{Fathers height} + \text{Mother's height} - 13}{2}$$

Growth velocity index (GVI) is provided as

GVI =

$$\frac{\text{Actual growth velocity}}{\text{Expected growth velocity for chronologic age}} \times 100$$

deviation score (SDS) is given as

SDS =

$$\frac{\text{Height}^2(\text{cm}) - \text{height (cm) at 50th percentile for age}}{\text{Standard deviation (SD) of height for age (cm)}}$$

Body Ratio

Upper/lower segments ratio (as measured from the pubis) at birth is 1.7:1. With the greater increase in the length

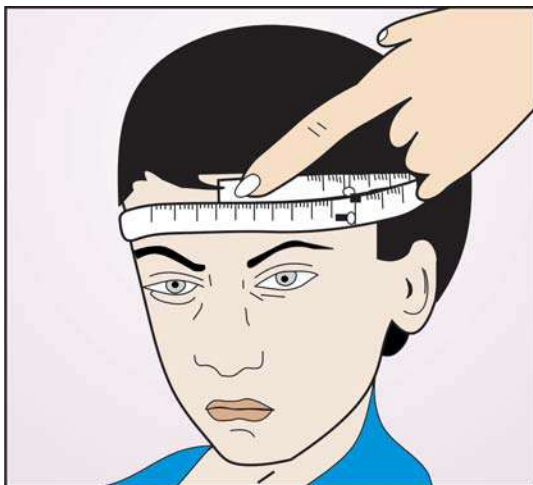

Fig. 3.6: Measurement of head circumference

of the legs compared to the trunk, the ratio is 1.3:1 at 3 years; after 7 years and, usually by the age of 10 to 12 years, the ratio becomes approximately 1:1.

Stem stature index refers to the sitting height (crown-rump length) as a percentage of the total height or recumbent length. It is 70 at birth, 66 at 6 months, 64 at 1 year, 61 at 2 years, 58 at 3 years, 55 at 5 years and 52 at puberty (SMR-3 for girls, SMR-4 for boys).

Span is the distance between tips of middle fingers when the arms are outstretched. It is equal to height at 10 years. In earlier years, it is 1 to 2 cm less than the length/height. After 12 years, it is 1 to 2 cm more than height.

Head

Size Head circumference which represents growth of the brain, measures 34-35 cm at birth, 41 cm at 3 months, 44 cm at 6 months, 47 cm at one year, 50 cm at 2 years, 51 cm at 7 years and 53 cm at 12 years.

For measuring head size, place the tape over the occiput at the back and just above the supraorbital ridges in front (midforehead) and measure the point of highest circumference (Fig. 3.6).

Generally speaking, if brain does not develop normally, as in mental retardation, the head size is likely to be small. (Fig. 3.7) are photographs of such a microcephalic baby. Occasionally, however, the



Fig. 3.7: Microcephaly in a one-year-old with multiple congenital deformities

small size of the head may be secondary to premature union of the skull sutures, the so-called *craniosynostosis* (also termed *craniostenosis*). Large head may be the result of hydrocephalus, rickets, chondrodystrophy or syphilis. It may even be as simple a thing as familial macrocephaly which is just harmless.

Shape A boat-shaped head suggests the scaphocephaly, asymmetrical the plagiocephaly and tomb-shaped the oxy- or acrocephaly. Flattened occiput may be a feature of Down syndrome whereas frontal and/or parietal bossing, or box-like head is suggestive of rickets.

Fontanels and Sutures At birth, there are 6 fontanels, one each anterior and posterior (Fig. 3.8) and 4 lateral (2 anterolateral and 2 posterolateral). Posterior and lateral fontanels close fairly early—usually within first few weeks. Anterior fontanel which is of much clinical value measures 3×2 cm and closes between 9 months to 18 months. Early closure may suggest craniostenosis or primary microcephaly. Late closure should arouse suspicion of rickets, congenital hypothyroidism, hydrocephalus, syphilis, protein-energy malnutrition, etc. Rare causes include achondroplasia, Apert syndrome, cleidocranial dysostosis, hypophosphatemia, rubella, prematurity, IUGR, osteogenesis imperfecta, trisomies and hypopituitarism. Occasionally, anterior fontanel patency may be familial.

A truly bulging anterior fontanel may indicate raised intracranial tension or pseudotumor cerebri. A depressed fontanel is a sign of significant dehydration.

Complete ossification of the *sutures* occurs in late childhood only, though by 6 months these are closed. A palpable ridge over the suture site suggests premature closure as in craniosynostosis. On the other hand, in hydrocephalus, sutures may be separated.

Wormian bones Soft areas in the occipital region may suggest *wormian bones* accompanying osteogenesis imperfecta, cleidocranial dysostosis, lacunar skull, cretinism or Down syndrome.

Craniotabes The abnormal softening and thinning of skull bones may be demonstrated by pressing the occipitoparietal area of skull with the thumb. There results indentation (a sort of “give”) like a pingpong (table-tennis ball). Craniotabes may be present in prematurity, marasmus, rickets, syphilis or osteogenesis imperfecta.

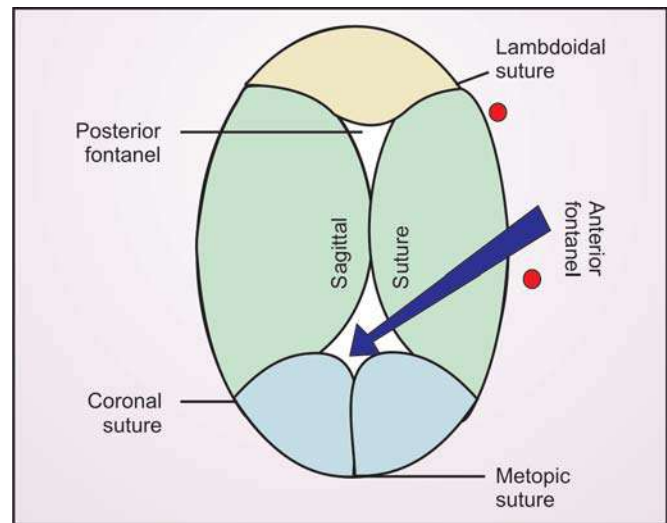

Fig. 3.8: Skull top, showing fontanels and sutures

Bruit An intracranial sound of venous or arterial origin on auscultation, particularly in temporal region, may well be a normal finding or evidence of an aneurysm or facial hemangioma.

Transillumination is indicated in cases of hydrancephaly.

Head/Chest Circumference Ratio

At birth, head circumference is larger than chest circumference by about 2.5 cm. By 6 to 12 months, both are equal. After first year, chest circumference tends to be larger by 2.5 cm. By the age of 5 years, it is more or less 5 cm greater in size than the head circumference.

For measuring chest circumference place the tape at the level of the nipple in a plane at right angle to the spine. Record the measurement in mid-respiration (Fig. 3.9, Table 3.1). Also see Chapter 11.

Midarm Circumference

Let the left arm hang naturally by the side of body. Then place the tape firmly but without compressing the tissues around the upper arm at a point midway between tip of the acromian and olecranon process (Fig. 3.10 and Table 3.2). In practice, the measurement of the upper arm would correspond to the one recorded at the midpoint. In preschool children, measurement < 12.5 cm means significant malnutrition. Also see Chapter 11.

Table 3.1: Chest circumference (cm) of children under six years

Age in Months	Harvard standard		Percentage of the Reference									
	95	90	85	80	75	70	65	60	55	50		
3	40.6	38.5	36.5	34.5	32.5	30.5	28.4	26.4	24.4	22.1	20.3	
6	43.1	41.5	39.2	37.0	34.9	32.7	30.6	28.4	26.2	24.0	21.9	
9	46.0	43.7	41.4	39.1	36.8	34.5	32.2	29.9	27.6	25.3	23.0	
12	47.3	44.9	42.6	40.2	37.8	35.5	33.1	30.7	28.4	26.0	23.6	
15	48.3	45.9	43.5	41.0	38.6	36.2	33.8	31.4	29.9	26.5	24.1	
18	49.2	46.7	44.3	41.8	39.4	36.9	34.4	32.0	29.5	27.1	24.6	
24	50.4	47.9	45.4	42.8	40.3	37.6	35.3	32.8	30.2	27.7	25.2	
30	51.5	48.9	46.3	43.8	41.2	38.6	36.1	33.5	30.9	28.3	25.7	
36	52.2	49.6	47.0	44.4	41.8	39.2	36.6	34.0	31.3	28.7	26.1	
42	52.3	50.2	47.5	44.9	42.2	39.6	37.0	34.3	31.7	29.0	26.4	
48	53.4	50.7	48.1	45.4	42.7	40.0	37.4	34.7	32.9	29.4	26.7	
54	54.0	51.3	48.6	45.9	43.2	40.5	37.8	35.1	32.4	29.7	27.0	
60	54.6	51.9	49.1	46.4	43.7	41.0	38.2	35.5	32.8	30.0	27.3	
Boys 66	55.3	52.5	49.8	47.0	44.2	41.5	38.7	35.9	33.2	30.4	27.6	
72	56.1	55.3	50.5	47.7	44.9	42.1	39.3	36.5	33.7	30.8	28.0	
Girls 66	53.7	51.0	48.3	45.6	43.0	40.3	37.6	34.9	32.2	29.5	26.8	
72	54.5	51.8	49.0	46.3	43.6	40.9	38.1	35.4	32.7	29.9	27.2	

Table 3.2: Arm circumference (cm) of children under six years

Age in Months	Wolanski standard		Percentage of the Reference									
	95	90	85	80	75	70	65	60	55	50		
Boys 5	12.1	12.1	11.4	10.8	10.2	10.6	8.9	8.2	7.6	7.0	6.4	
6	14.5	13.8	13.1	12.4	11.6	10.9	10.2	9.4	8.7	8.0	7.5	
9	15.8	15.0	14.2	13.4	12.6	18.1	11.0	10.2	9.5	8.7	7.9	
12	16.0	15.2	14.4	13.6	12.8	12.0	11.2	10.4	9.6	8.8	8.0	
15	16.1	15.3	14.5	13.7	12.9	12.1	11.3	10.5	9.7	8.8	8.0	
18	15.7	14.9	14.1	13.3	12.5	11.9	11.0	10.3	9.4	8.6	7.8	
21	16.2	15.4	14.6	13.7	13.0	12.1	11.4	10.5	9.7	8.9	8.1	
24	16.3	15.5	14.7	13.8	13.3	12.2	11.4	10.6	9.8	8.9	8.1	
30	16.4	15.6	14.8	13.9	13.1	12.3	11.5	10.7	9.9	9.0	8.2	
36	16.2	15.4	14.6	13.7	13.0	12.1	11.3	10.5	9.7	8.9	8.1	
42	16.5	15.7	15.0	14.0	13.2	12.4	11.6	10.7	9.9	9.1	8.2	
48	16.9	16.0	15.2	14.4	13.5	12.7	11.8	11.0	10.1	9.3	8.4	
54	17.5	16.6	15.5	14.9	13.8	13.1	12.1	11.4	10.4	9.6	8.7	
60	17.0	16.1	15.3	14.5	13.6	12.8	11.9	11.1	10.1	9.4	8.5	
Girls 3	13.3	2.7	12.0	11.3	10.6	9.9	9.3	8.9	8.0	7.3	6.7	
6	14.3	3.6	12.9	12.2	11.5	10.7	10.0	9.3	8.6	7.9	7.2	
9	15.3	14.5	13.7	12.9	12.2	11.7	11.4	9.9	9.2	8.4	7.7	
12	15.6	14.8	14.0	13.3	12.5	11.7	10.9	11.7	9.4	10.1	7.8	
15	15.7	14.9	14.1	13.3	12.5	11.9	11.0	10.3	9.4	8.6	7.8	
18	16.1	15.3	14.5	13.7	12.9	12.1	11.3	10.5	9.7	8.8	8.0	
21	15.9	15.1	14.3	12.5	12.7	11.9	11.1	10.3	9.6	8.7	7.9	
24	15.9	15.1	14.4	12.5	12.8	11.9	11.2	10.3	9.6	8.7	7.9	
30	16.4	15.6	14.8	13.9	13.1	12.3	11.5	10.7	9.8	9.0	8.2	
36	15.9	15.1	14.3	12.5	12.7	11.9	11.1	10.3	9.6	8.7	7.9	
42	16.3	15.5	14.7	13.8	13.1	12.2	11.4	10.6	9.8	8.9	8.1	
48	16.9	16.0	15.2	14.8	13.5	13.7	11.8	11.0	10.2	9.3	8.4	
54	16.6	15.8	15.1	14.1	13.4	12.4	11.7	10.8	10.1	9.1	8.1	
60	16.9	16.0	15.2	14.3	13.5	13.7	11.8	11.0	10.1	9.3	8.4	
Boys & Girls 72	17.3	16.4	15.6	14.7	13.8	13.0	12.1	11.2	10.4	9.5	8.5	

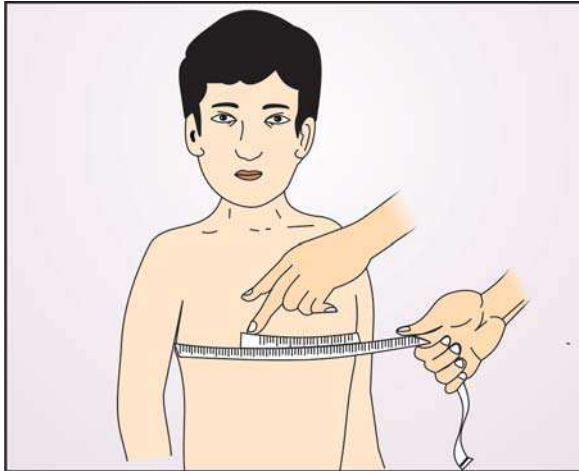

Fig. 3.9: Measurement of chest circumference at the level of the nipples

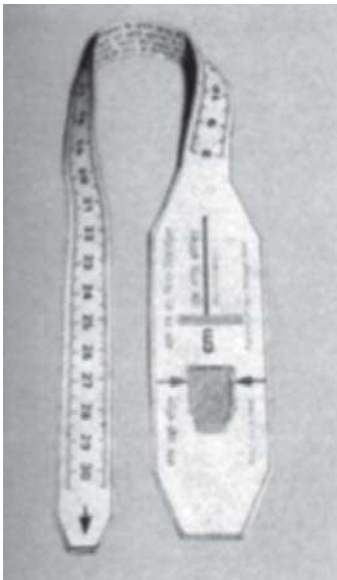

Fig. 3.10: Midarm circumference tape (MAC)

Skin-fold Thickness

Of the various skin-folds, triceps skinfold is the most popular. It is recorded by a specialized instrument, *Lange's or Herpenden's skin-fold callipers*, at the mid-arm over triceps area on the left side. Hold a fold of skin between thumb and index finger and measure.

Ratio of total body water and body weight is a more accurate index of body fat, correlating at about 0.62 with skin-fold thickness (Table 3.3).

Body Mass Index (BMI)

BMI correlates well with the subcutaneous fat and the total body fat and, yet allows a variation in the

lean body mass. It is given by the following formula:

BMI =

BMI remains constant (15 - 25 kg/met²) up to the age of 5 years. A BMI > 25 kg/met² points to overweight and > 30 kg/met² establishes existence of obesity. A BMI < 15 kg/met² points to malnutrition.

Dentition

It is not a dependable parameter for assessment of growth since there is a wide variation in eruption of teeth and its timing. The average age at which first tooth erupts is 6 to 7 months. The rest of the *milk, deciduous* or *temporary teeth* appear at the rate of one tooth every month. Thus, the number of teeth in an infant are: age in months minus 6. By 2½ to 3 years the child has a full set of temporary teeth numbering 20. Generally, the lower central and lateral incisors erupt earlier followed by first molars, cuspids and second molars in succession.

Rarely, a baby may be born with an already erupted tooth (natal tooth). It is harmless as long as it is not loose and does not interfere with feeding.

Delayed eruption of first tooth (upto as late as 15 months) in a normal child is also seen. Likewise, late appearance of other teeth may also be there. Among the possible factors responsible for delayed dentition, familial and/or racial tendency, poor nutritional status, rickets and osteogenesis imperfecta are important. Very infrequently, a child may have an absolute non-eruption of teeth (*anodontid*) which is a classical feature *ofectodermal dysplasia*.

Discoloration of temporary teeth right from the start may well be related to ingestion of tetracyclines by the mother during the third trimester of pregnancy.

There is no truth in the commonly-held belief that teething causes diarrhea or fever. However, teething may be responsible for excessive salivation and drooling, irritability, painful gums and disturbed sleep. Local application of choline salicylate and an oral analgesic or a mild sedative should suffice.

The first permanent teeth—the 6-year-molars—are sometimes confused with the temporary teeth.

Tables 3.4 and 3.5 summarize the pattern of eruption of temporary and permanent teeth. The number of temporary and permanent teeth is shown in Table 3.6.

Age	Biceps skinfold (mm)		Triceps skinfold (mm)		Mid-arm circumference (cm)	
	Male	Female	Male	Female	Male	Female
Birth	—	—	4.8	5.0	12.2	12.0
1 Year	6.5	6.6	10.0	9.6	12.6	12.5
3 Years	5.8	6.2	9.5	9.9	13.6	13.3
6 Years	4.6	5.6	7.9	8.2	14.9	14.8
9 Years	4.1	4.2	7.4	7.8	16.5	16.5
12 Years	4.2	4.2	8.0	8.1	17.4	18.2
15 Years	3.8	3.8	7.3	7.4	20.3	20.6

Birth	Nil
6 to 7 months	Central incisors
By 10 months	Laterals incisors
1 to 1½ years	First molars
1¼ to 1¾ years	Cuspids (Canines)
2 to 3 years	Second molars

Age	Eruption
6 years	First molars
8 years	Central and lateral incisors
9 years	Bicuspid (anterior)
10 years	Bicuspid (posterior)
11 to 12 years	Canines
12 to 13 years	Second molars
17 to 25 years	Third molars (wisdom teeth)

Temporary	$\frac{edcbaabcde}{edcbaabcde}$	20
Permanent	$\frac{87654321\ 12345678}{87654321\ 12345678}$	32

Bone Age

Bone age means age as calculated from the maturation and appearance of epiphyses.

An average full-term newborn has the following 5 radiologically demonstrable ossification centers:

- Distal end of femur
- Proximal end of tibia
- Talus
- Calcaneus
- Cuboid

By the age of 6 months, ossification centers for two carpal bones, i.e. capitate and hamate, appear. It will be a useful guide to remember that number of centers at wrist is equal to age in years plus one. Thus, a child of 2 years should have 3 centers in an X-ray of wrist.

Box 3.1 gives the recommended sites for bone age determination radiologically.

Epiphyseal development of girls is consistently ahead of the boys.

Advanced bone age may occur in thyrotoxicosis, adrenal hyperplasia, precocious puberty, gigantism, pseudohypoparathyroidism, acrodysotosis, leprechaunism and the newly-described syndrome of accelerated skeletal maturation and relative failure to thrive. In rheumatoid arthritis and arteriovenous malformation of a limb, only the affected bone(s) may show an advanced bone age.

Retardation in bone age is a characteristic feature of congenital hypothyroidism.

Usually epiphyseal (supernumerary centers, pseudoepiphysis and notches) and sometimes non-epiphyseal anomalies may well indicate such pathologic states a malnutrition encephalopathies, endocrinopathies. Down syndrome or congenital and familial structural defects.

Appearance of secondary epiphyseal centers for various bones and their fusion with the diaphysis occurs in a standard sequence, forming basis for assessment of bone age radiologically.

Newborn	Foot and ankle
3-9 months	Shoulder
1-12 years	Hands and wrists
12-14 years	Elbow and hip

1 LINEAR CATCHUP GROWTH

Monitoring linear catchup growth is of great clinical importance because of its value in measuring the efficacy of therapy in impaired growth.

Definition

It is defined as height velocity above statistical limits of normal (supranormal) for age and/or maturity during a defined period of time following a transient period of growth inhibition. Catchup growth is intended to revert the child to his pre-retardation growth curve. It is the rapid growth targeted at making up for the loss of potential tissue.

Remember, catchup growth is not the same as compensatory growth. The latter is the growth that occurs after the loss of the actual mass of tissue that is controlled by a simple feedback mechanism working on physiological mass. An illustrative example is that of the liver regeneration following its partial resection.

In quite a proportion of cases, it is possible to foresee the extent of likely catchup growth. As for instance, short periods of growth arrest at a young age with prompt elimination of inhibitory factors and institution of suitable therapy usually leads to attainment of full catchup and potential target height. Nevertheless, catchup growth is likely to be significantly less in case of recurrent episodes of growth inhibitory factors.

Influencing Factors

Principle factors influencing it include:

- Nature, intensity and duration of the causative growth disorder responsible for retardation in height.
- Stage of initiation, type, duration, effectiveness and magnitude of nutritional therapy.
- Stage of growth of the child.

Types

Type 1 It occurs in infancy and childhood. Once the cause for retardation is removed (say gluten-free diet in celiac disease), height velocity may shoot up as much as 4 times the normal for the chronologic age. The height deficit is, therefore, rapidly eliminated.

Type 2 It occurs in adolescence. Once the cause for retardation is removed, growth continues for longer

than usual to compensate for the growth arrest but there is either little or no increase in height velocity compared to the mean for chronologic age.

Type 3 It is a mixture of type 1 and 2. Here, once growth restriction stops an increase in height velocity and a delay and prolongation of growth occurs.

Operative Factors

Two important factors, namely GH and IGF-1 play vital role in linear growth which is indeed the result of recruitment of new progenitor cells from the stem layer and the number of cell divisions in the hypertrophic layer. Obviously, the hormonal factors (especially the somatotrophic axis) and the epiphyseal growth plate are of paramount importance in catchup growth.

Yet, the exact modus operandi of regulation of catchup growth remains unclear.

Tanner's time tally/neuroendocrine hypothesis According to this hypothesis, catchup stimulus is provided by a balance of several hormones released or coordinated by pituitary.

Growth plate hypothesis According to this hypothesis, catchup growth is intrinsic to the growth plate and not to the CNS.

William's cellular hypothesis There is no single mechanism that regulates catchup growth. Growth is a cellular phenomenon in which cell has a program and a mechanism to recognize its placement in the program. A dynamic stabilizing mechanism tends to bring it back to the right course in case it goes astray. The growth hormone coordinates the tissues and the organs at the program level.

GROWTH (REFERENCE) STANDARDS: LOCAL OR INTERNATIONAL?

The question whether the developing countries should use international growth standards or develop their own standards for comparison has been considerably debated.

The argument that all children have same genetic potential/especially in early years, and their growth is more influenced by nutrition, illness and environment rather than by heredity, and that growth of children of affluent groups in developing countries compares favorably with that of children in the developed countries had led World Health Organization (WHO) recommend use of data collected

from North American children as the single international reference standard to replace the earlier Harvard data. These data were popularly referred to as 1977 National Center of Health Statistics (NCHS) data. Following further revision in 2000, CDC Growth charts and CDC Growth Tables are remained in use. More recently, in 2006, based on data on breastfed children, diverse ethnic background and cultural settings (the participating countries included India, Oman, Ghana, Brazil, Norway and United States), the WHO introduced new growth charts. The WHO recommends their universal use. The contention behind this recommendation is that differences in children's growth up to 5-year of age are more influenced by feeding practices, environment and healthcare rather than genetic or ethnic factor. In other words, children born anywhere in the world and given the optimum start in life have the potential to grow within the same range of height and weight.

PUBERTY (*Adolescence*)

Puberty or adolescence is defined as the period during which sexual maturation occurs and the body assumes final adult shape.

Detailed discussion on adolescence is available in Chapter 7.

DEVELOPMENT

Development is defined as "acquisition of qualitative and quantitative skills/competencies in a social milieu". It depends on maturation and myelination of brain. It is a continuous process.

Development of the child is assessed in the following four areas:

1. Gross motor development: It pertains to control of the child over his body and is observed in ventral suspension, supine, prone, sitting and standing positions.
2. Fine motor and adaptive development: It pertains to fine coordination of eyes, hand-eye, and hand-mouth, and skills for manipulation with hands.
3. Personal/social development: It pertains to interpersonal and social skills like social smile, mimicry, waving "bye-bye", etc.
4. Language development: It pertains to hearing, sounds, understanding and true speech.

NORMAL DEVELOPMENTAL MILESTONES

Box 3.2 gives the important normal milestones.

Box 3.2: Important normal milestones

Gross motor

Head/neck holding	3 months
Sitting (with support)	5 months
Sitting (without support)	7-8 months
Standing (with support)	9 months
Walking with support	10 months
Crawling/creeping	11 months
Standing (without support)	12 months
Walking (without support)	13 months
Running	18 months
Climbing upstairs	24 months
Riding cycle	36 months

Fine motor

Grasping a rattle (when placed in hand)	4 months
Reaching out for a bright object (intentional reaching) and grasps it with both hands (bidextrous grasp)	5 months
Holding an object with crude grasp from palm (palmar grasp)	7 months
Holding a small object between index finger and thumb (pincer grasp)	9 months

Personal/social

Social smile	4-8 weeks
Recognition of mother	3 months
Smiling at mirror image	6 months
Waving "bye-bye"	9 months
Playing a simple ball game	1 year
Knowing gender	3 years

Language

Turning head to sound (rattle, ball)	1 month
Cooing	3 months
Monosyllables (ma, pa, ba)	6 months
Bisyllables (mama, papa, baba)	9 months
Two words with meaning	1 year
Simple sentence	2 years
Telling a story	3 years
Account of recent events	4 years

ASSESSMENT OF DEVELOPMENT

Developmental screening, a brief testing procedure designed to identify children who should receive more intensive diagnosis or assessment, is essential so as to detect abnormal developmental delays. The most widely used screening for detecting developmental delays in infancy and preschool years

is by what has now come to be known as Denver Developmental Screening Test (DDST). For older children, 3 to 15 years, one may use the development charts. Remember, assessment of development must not be confused with assessment of general intelligence using such tests as Stanford Binet intelligence scale, Wechsler intelligence scale and Goodenough draw a man test.

Denver Developmental Screening Test (DDST)

Developed in 1967, DDST assesses development of infants and preschool children (usually upto 3 years) in 4 vital areas, namely gross motor, fine motor adaptive, language, and personal social behavior. There are 105 items, some of which are indeed difficult to administer. Moreover, it is inappropriate for children with mothers who are not having enough education and has less items related to language. A short DDST is available but it has got to be followed by the full DDST subsequently for dependable results.

Denver II (Modified DDST)

Recently, major revision, modification and standardization of the DDST has occurred in the form of Denver II which has 125 items instead of 105. The major differences from the original test are:

- An 86% increase in language items
- Two articulation items
- A new-category of item interpretation to identify milder delays
- Behavior rating scale
- New training materials
- Higher interrater and test-retest reliability
- Designation of "caution" items
- Identification of items for which there is a clinically significant difference between the norms of one or more subgroups and the composite norms of the total samples.

Denver II has following plus points over DDST:

- Availability of Denver II Screening Manual
- Availability of Denver II Technical Manual
- Availability of a video instructional program and proficiency test.

Note that it is only a screening test for identifying children who are not performing as their agemates, irrespective of the reason(s). It does not measure intelligence or developmental quotient.

Attempts are being made to produce a short (abbreviated) Denver-II needing just 5 minutes for assessment.

Goodenough draw-a man-test is a paper-pencil test meant for 3-15 year age group. The child scores as many points as the number of items he includes in his drawing. For every 4 points he is awarded one year that is added to the basal age (3 years). For example, eight-year-old who includes 16 items in the drawing attains a score of 4 years.

His mental age = 3 + 4 = 7 years.

$$\begin{aligned} \text{Hence, IQ} &= \frac{\text{Mental age}}{\text{Chronologic age}} \times 100 \\ &= \frac{7}{8} \times 100 = 87 \end{aligned}$$

Baroda DST

The *Baroda screening test* has 25 test items listed according to child's age. It is primarily developed for use of the child psychologists rather than pediatricians. In order to have a suitable developmental screening test for Indian children, it was adopted from Baryley development scale by Phatak from Baroda. The test is relevant for age 0-30 months. Domains evaluated are gross motor, fine motor and cognitive. Administrative time is 10 minutes. Sensitivity is 0.66-0.93; specificity is 0.77-0.94.

Trivandrum DST

This test is based on Baroda norms and has 17 test items (Table 3.7). It is relevant for age 0-2 years. Domains evaluated are gross motor, fine motor and

Table 3.7: Trivandrum development screening chart*

Test items	3rd percentile	97th percentile
1. Social smile	0.1	2.7
2. Eyes follow pen/pencil	1.1	3.9
3. Holds head steady	1.1	3.8
4. Rolls from back to stomach	2.7	10.0
5. Turns head to sound of bell/rattle	3.0	5.8
6. Transfers objects hand to hand	4.1	7.0
7. Raises self to sitting position	5.8	11.0
8. Standing up by furniture	6.3	11.0
9. Fine prehension pellet	6.7	10.9
10. Patacake	6.7	12.7
11. Walk with help	7.7	13.0
12. Throws ball	9.5	16.7
13. Walk alone	9.9	17.7
14. Says two words	11.2	19.1
15. Walks back wards	12.2	19.5
16. Walks upstairs with help	12.2	24.4
17. Points to parts of a doll (3 parts)	15.3	24.3

* Please also see chart in IAP Health Records attached with this chapter

cognitive. Administrative time is 5 minutes. Validity and specificity are 0.67 and 0.79, respectively.

Other Development Screening Tests

These include Gessell DST, Bayley DST, Woodside DST, developmental profile (DP-II), cognitive adaptive test/clinical linguistic auditory milestone scale (CAT/CALMS), early language milestone scale (ELM) and Vineland social maturity scale.

APPROACHES TO DEVELOPMENTAL SCREENING

- *Informal screening* It aims at correctly identify children with subtle developmental delays through informal screening methods such as observations during routine pediatric checkup and obtaining information from parents about their concerns concerning child's developmental milestones at various ages.
- *Routine formal screening* It consists in systematic developmental screening of all children with the help of standardized screening instruments. This approach is neither feasible nor cost-effective
- *Focused screening* It comprises developmental screening in the following situations
 - Children whose parents and/or teachers suspect developmental problems
 - High-risk neonates (for developmental delay) as per Table 3.8.

The guidelines for developmental screening are summarized in Table 3.9.

In nutshell, the pediatrician should rely on a combination of clinical judgement, based on history, physical examination and office observations, parental concerns, and formal screening test to identify children with developmental disability. Once identification of developmental delay has been made, early treatment and intervention must begin before it affects the functioning of the child and the family.

Table 3.8: High-risk neonates (for developmental delay) in need of focused developmental screening

- Very LBW infants
- Neurologic conditions: IVH (Grades 3 & 4), HIE, Apgar score 0-3 at 10, 15 and 20 minutes, periventricular leukomalacia, meningitis, persistent seizures, apnea beyond term
- Hyperbilirubinemia
- Septicemia.

Table 3.9: Guidelines for developmental screening

- Screening instrument should be
 - Reliable
 - Culturally relevant
 - Used only for specified purpose
- Multiple sources of information should be used.
- Developmental screening should be done only by trained personnel
- Screening should be on a recurrent and periodic basis
- Family members should be part of the screening process.

FURTHER READING

Articles/Chapters

1. Center for Disease Control. CDC growth charts. Available at <http://www.cdc.gov>. Accessed on 12 Nov 2006.
2. Khadelkar VV, Khadelkar AV, Choudhury P, *et al*. IAP growth monitoring guidelines for children for birth to 18 years. *Indian Pediatr* 2007;44:187.
3. Nair MKC. Simplified developmental assessment. In Gupte S (Ed): *Recent Advances in Pediatrics-2*. New Delhi: Jaypee 1992:76.
4. Phatak P, Dhapre M, Pandit AN, Kulkarni S. A study of Baroda development screening test of Indians. *Indian Pediatr* 1991;28:843-849.
5. Reddy V. New WHO growth standards for young children. *Indian Pediatr* 2006;43:851.
6. Saxena A, Phadke SR, Agarwal SS. Linear catchup growth. *Indian JPediatr* 2000;67:225.

Book/Monograph

1. World Health Organization. *WHO Child Growth Standards*. Geneva: WHO 2006.

CHAPTER



Growth Disorders

Suraj Gupte

FAILURE TO THRIVE (FTT)

Defintion

The term, *failure to thrive (FTT)*, is applied to infants and young children (usually up to the age of 2-3 years) who show failure of expected weight gain and striking lack of wellbeing. It is a descriptive and not a diagnostic term. The essential component in FTT is sluggish weight gain. However, sluggish length/height gain and/or development may accompany it.

Many authorities believe that the term is more or less synonymous with the psychosomatic growth failure or maternal deprivation syndrome.

Etiology

Experience has demonstrated that by far the most common cause of failure to thrive is poor nutritional intake and feeding problems. A careful history would elicit this and also poverty, ignorance and conflict in the family. Thus, parental neglect too operates a great deal in its causation.

An important cause in developing countries is the one or more types of intestinal parasites infesting the child's gut.

Yet another factor is the relatively common occurrence of tuberculosis in our infants and children. Besides this, failure to thrive may well be because of several other organic (usually chronic) diseases. For a comprehensive list, see Table 4.1.

Clinical Features

The infant is underweight for age (usually < 3rd percentile) (Fig. 4.1). He may appear small in size with

Table 4.1: Etiology of failure to thrive (FTT)

Extrinsic causes

Poor dietary intake: Maternal malnutrition, LEW, erratic feeding practices

Social and emotional deprivation: CAN, inadequate infant-mother bonding, unwanted child, parental disharmony, inexperienced or psychopath mother

Intrinsic causes

Malabsorption: Celiac disease, cystic fibrosis, lactose intolerance

Intestinal parasitosis: Giardiasis, ascariasis

Persistent vomiting: Pyloric stenosis, GERD

Metabolic: Galactosemia, diabetes mellitus, congenital adrenal hyperplasia

Chronic illnesses: Congenital heart disease, asthma, ICC

expressionless facies, poor gross motor activity, delayed vocalization and poor response. He tends to remain absorbed in thumb-sucking.

Beyond infancy, the child is underweight, thin and inactive.

Diagnosis

It is based on good history, physical examination and growth chart.

Treatment

After preliminary screening, including meticulous stool microscopy on at least three successive days, the child should be put on trial of feeding for a minimum of two weeks. If workable, it should be done after admitting the child to the hospital. During this period, you must make sure that the child gets enough food. At the same time, intestinal parasites, if detected in the stools, should be treated.

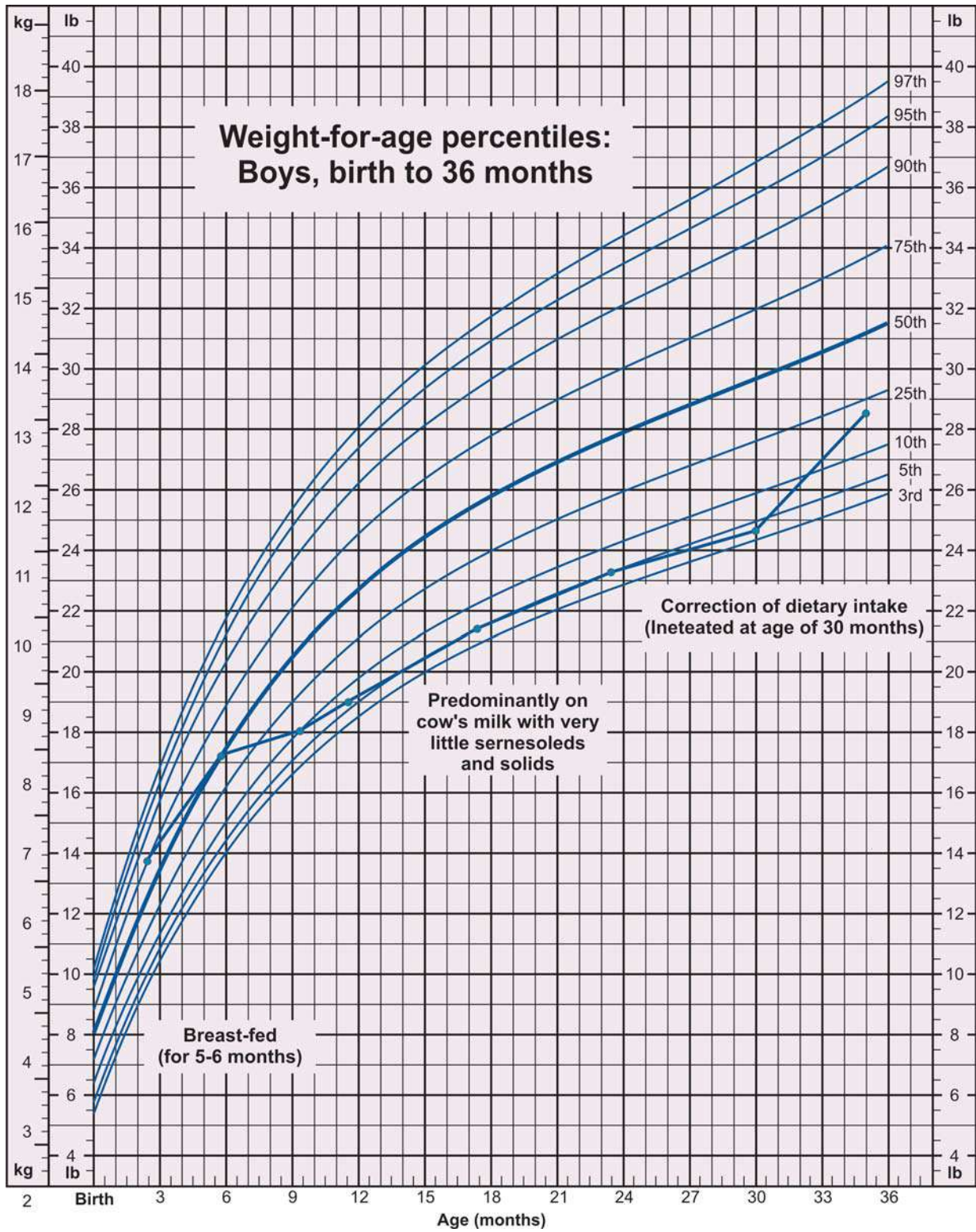

Fig 4.1: The growth chart depicting failure to thrive (FTT). Note the poor weight gain between age 6 and 18 months when the child was predominantly on cow's milk with very little semisolids and solids. Correction of dietary intake resulted in restoration of weight gain

Attention should be directed to the emotional needs of the child and in improving parent-child relationship as also in removing the conflicts.

If this line of management yields unsatisfactory results, the child needs to be further investigated on rather sophisticated lines for the exact etiologic diagnosis.

Long-term Sequelae/Consequences

1. Growth retardation
 2. Developmental retardation
 3. Learning difficulties.
- Risk of long-term consequences is more in
- Nonorganic FTT
 - Organic FTT where etiologic diagnosis and appropriate treatment is delayed.

THE CHILD WITH SHORT STATURE

Deflation

Short stature is defined as length/height

- below 3rd percentile for age, or
- below more than 2 standard deviations (SD) of mean forage.

In addition, the height velocity is usually < 25th percentile for age.

Etiology

Short stature is a common pediatric problem. Most enlightened parents are keen to know if their child, who had not been keeping pace with the healthy peers of his age, "is heading for dwarfism." Obviously, the doctor must evaluate the child fully, bearing in mind that a large number of etiologic factors can lead to short stature.

Table 4.2 gives etiologic classification of short stature.

Short stature may be primary or secondary. Primary short stature is usually due to an intrinsic defect in the skeletal system as a result of some genetic or prenatal damage (say, IUGR). Here, potential for normal bone growth is impaired though skeletal age is unaffected. Main effect is on diaphyseal growth.

Secondary short stature is characterised by impairment of bone age and height to the same extent. Here, the potential for reaching the adult height is subject to availability of proper treatment.

Table 4.2: Causes of short stature

A. Proportionate Short Stature

Normal Variants

Familial

As a result of unknown genetic factor(s); runs in family members of varied generations.

Constitutional

Delayed skeletal growth, "less height" for chronologic age (child looks all right for his weight, however) and delayed puberty are the characteristic features. These children—once they cross the early childhood—finally reach normal adult height.

Prenatal Origin

IUGR: Maternal diabetes, toxemias, infections, teratogens (alcohol, nicotine, etc)

Dysmorphic syndromes: Silver-Russell syndrome

Chromosomal anomalies: Turner syndrome, Down syndrome

Postnatal Origin

Nutritional

Malnutrition spread over a prolonged period (Fig. 4.2)

Organic Diseases

Gastrointestinal: Malabsorption syndrome in the form of celiac disease, endemic tropical sprue or cystic fibrosis of pancreas, heavy intestinal parasitism, cirrhosis of liver, congenital megacolon.

Cardiovascular: Congenital heart disease, rheumatic heart disease.

Respiratory: Pulmonary tuberculosis, bronchial asthma, bronchiectasis, cystic fibrosis of pancreas. *Hematologic:* Chronic anemia (IDA, thalassemia)

Endocrinal: Pituitary dwarfism, hypothyroidism, hypogonadism, Dysmorphic syndromes precocious puberty, pseudohypoparathyroidism, diabetes mellitus. Cushing syndrome, Laurence-Moon-Biedl syndrome, Frohlich syndrome.

Renal: Renal rickets from chronic renal failure and tubular disorders

Chronic Infection

Tuberculosis, malaria, syphilis, heavy parasitic infestation, *H. pylori* infection.

Drug Induced

Prolonged use of anabolic steroids or corticosteroids.

Psychosocial

Emotional deprivation, parental neglect, CAN.

Primordial

As a result of intrauterine factors that cause low birthweight.

B. Disproportionate Short Stature

Short limbs

Congenital hypothyroidism, achondroplasia (Fig. 4.3), osteogenesis imperfecta, amelia, rickets

Short trunk

Mucopolysaccharidoses (gargoylism, Morquio disease), caries spine, hemivertebrae

Rickets



Fig. 4.2: Short stature in a child with acute on chronic PEM (nutritional dwarfing) against a control (both 5½-year-old)



Fig. 4.3: Disproportionate short stature in a child with achondropasia. Note the short extremities (maximum brunt on proximal segment i.e. rhizomelia)

Diagnostic Approach

Evaluation should be based on a good history and physical examination, routine investigations, bone age and study of growth rate. Hormonal studies and karyotyping are needed in selected cases.

In anthropometry, *height velocity* is more useful than a single recording of the height. It is calculated from at least two accurate readings at a gap of 6 months (preferably one year). A velocity of less than 4 cm per year between 5 years of age and adolescence is considered pathologic. For younger children, it varies with age: 15 cm for 0 to 6 months, 7 cm for 6 to 12 months, 10 cm for 1 to 2 years, and 5 cm for 2 to 5 years.

Body proportions are considered to be most accurate index of height. Upper segment/lower segment ratio is increased in hypothyroidism and short-statured dwarfism (achondroplasia).

Measurement from midfinger tip to midfinger tip (span) is case of fully outstretched arms and hands is increased (more than height) in spondyloepiphyseal dysplasia (Morquio disease).

Measuring parents' height is of value. The so-called *midparental height*, a genetic component, gives the subject's target height. It is determined as mean of

father and mother's heights plus 13 in case of boys and minus 13 in case of girls.

If weight is less proportionally reduced than height, nutritional deprivation must be seriously considered. On the contrary, if weight is nearly normal but height is significantly less, hypothyroidism must be seriously considered. Growth hormone deficiency and hypercorticism also figure in the differential diagnosis.

Pubertal staging is done by Tanner's classification (Chapter 7).

Children with delayed puberty and short stature should arouse suspicion of sex chromosomal anomalies such as Turner syndrome. Here stature, despite timely onset of puberty, is likely to end up with short stature. In "late maturers", both short stature and delayed puberty coexist. These latematurers ultimately attain better heights compared to early-maturers.

Bone age, assessed through radiologic examination of certain bones and then comparing the appearance and fusion of epiphyseal centers with standard normal radiographs for different ages, is of considerable value. In infancy, knee, wrist and hand and in later years elbow, wrist and hand are appropriate sites.

With the availability of assessment mentioned so far, the following guidelines are suggested:

- If height age falls within 2 years of the chronologic age, the subject need not be considered to have short stature.
- If height age is less than the chronologic age and the bone age equal to height age, slow growth—in other words constitutional delay—is the likely cause of short stature. In this situation, the child may well to attain his normal height subsequently.
- If the height age is less than the chronologic age and the bone age equal to chronologic age, genetic short stature is the diagnosis. Such a child has short parents and is likely to remain short.
- If bone age is less than chronologic age, one should consider constitutional growth retardation, hypothyroidism, malnutrition, growth hormone deficiency and chronic systemic disease as the cause of short stature. Besides radiology and routine investigations, including meticulous stool examination on at least 3 successive days, it should be ascertained if there is need for intensive workup. The indications for such a workup include.
 - Height over 2SD less than the mean for that age
 - Growth(height) velocity less than 4 cm per year
 - Growth centile showing subnormality in relation to family stature (midparental height)
- Inappropriate bone age compared to height age and actual (chronologic) age
 - Existence of characteristic features of an endocrinal cause or a syndromal state, .

Specific investigations include:

- Buccal smears
- Thyroid function tests
- Somatomedin-C measurement
- Cortisol, LH, FSH, PRL, testosterone, estrogen levels
- Urinary iodine levels
- Complete karyotyping
- Malabsorption studies
- Renal acidification test
- Urinary aminoacidogram
- Imaging studies like ultrasound, CT scan (pituitary, adrenals, pelvic organs).

Management

Management depends on the underlying cause (Table 4.3). Even if no treatable cause is found, the situation should be explained to the parents.

Table 4.3: Line of treatment in short stature

General: Good balanced diet, wormicidals, hematinics, zinc
Growth hormone deficiency: Replacement therapy
Hypothyroidism: Replacement therapy
Turner syndrome: Low dose estrogens, anabolic steroids
Systemic diseases: Specific therapy
Idiopathic (ISS): Zinc supplementation
Skeletal dysplasia: Limb lengthening surgery possible though expensive and risky.
Familial and IUGR: No treatment

Only established indication for growth hormone therapy is growth hormone responsiveness in cases of:

1. Biochemical GH deficiency supported by stimulation test(s), after thyroid function has been shown to be normal, plus slow growth velocity, and
2. Slow growth velocity in idiopathic short stature.

Today's genetically-engineered GH i.e. recombinant human GH (rhGH) therapy costs US \$ 4000 to 8000 (Rs. 162 thousand to 324 thousand). It is mandatory to start such a therapy before 11 years of age for attaining the optimal height. Recombinant GH is administered in a daily dose of 0.1 unit/kg (SC), preferably at night, until adult height is attained. Usually height gain is 10-12 cm in first year and 6-8 cm every year subsequently. More recently, it has been advocated that GH therapy should preferably be monitored by insulin-like growth factor-1 (IGF-1) to ensure safety and efficacy of GH. Excess GH and IGF-1 exposure and malignancy are known risks of GH therapy.

OBESITY

Despite overwhelming problem of nutritional deficiencies in India and other developing countries, obesity too is encountered, especially among the infants and children of the elite who ape the lifestyle of the west. The topic is discussed in Chapter 34, on Pediatric Endocrinology.

FURTHER READING

Articles/Chapters

1. Bodhankar U, Girish M. The child with failure to thrive. In Gupte S (Ed): *Textbook of Pediatric Nutrition*. New Delhi: Peepee 2006:335-339.

2. Chawla A. Failure to thrive. In Gupte S (Ed): *Pediatric Gastroenterology, Hepatology and Nutrition*. New Delhi: Peepee 2008.
3. Palwlikowska-Haddal A, Cohen P. Editorial: Advances in pediatric growth hormone therapy: IGF-1-based dosing. *Indian Pediatr* 2006;43:577-581.
4. Park P, Cohen P. The role of insulin-like growth factor-1 monitoring in growth hormone-treated children. *Horm Res* 2004;62:59-65.
5. Zargar AH. Short stature. In Gupte S (Ed): *Recent Advances in Pediatrics (Special Vol 13: Pediatric Endocrinology)*. New Delhi: Jaypee 2004:49.

Book/Monograph

1. Loveleen CE. *Disorders of Stature*. Boston: Acsdenicia Williams 1999.

CHAPTER



Developmental Disorders

Suraj Gupte

DEVELOPMENTAL DELAY

Definition

If the child fails to attain the key milestones by the expected age (which is a range rather than a fixed point), he is said to suffer from developmental delay. Around 10% children are estimated to suffer from developmental delay. For average ages at which various developmental milestones are attained, see Chapter 3 (Growth and Development).

Causes (Table 5.1)

Table 5.1: Causes of developmental delay

Bad obstetrical history: Abortion/miscarriage
Maternal illnesses during intrauterine life: Toxemias, infections (TORCH/STORCH)
Perinatal problems: Obstetric complications, HIE, LBW/prematurity, multiple pregnancy, neonatal seizures, IVH, septicemia, meningitis, kernicterus,
Nutritional Factors: Chronic PEM
Social Factors: Poor socioeconomic status, teenage mother, mentally retarded parent(s)
Organic Disorders: Genetic disorders (PKU), chromosomal aberrations (Down syndrome, Turner syndrome), blindness, deafness, post-meningitis/encephalitis sequelae

Diagnosis

Early recognition of developmental delay by simple methods is important. Detailed examination can be carried out later to find its cause. Some developmental disorders (say CP) may be picked up in infancy *per se*. Speech disorders, hyperactivity and emotional disturbances usually need waiting for 3-4 years and learning disabilities till schooling begins.

For developmental screening, see Chapter 3.

Management

The following measures of “early stimulation” help many infants and children to grow out of the suspected developmental delay:

- Playing with him
- Giving him toys for manipulation
- Putting up efforts to make him sit, stand and walk
- Showing him bright catchy objects
- Talking to him; provoking him to speak
- Encouraging him to interact with others.

LEARNING DISABILITY (DYSLEXIA)

The term denotes “a disorder in one or more of the basic processes involved in understanding or in using language (spoken or written), that may manifest itself in an imperfect ability to listen, speak, read, write, spell or to do mathematical calculations. In other words, this is a disorder that interferes with child’s ability to store, process or reproduce information. The disability may be mild enough to remain undetected throughout life. The celebrities Edison, Einstein and Leonardo da Vinci reportedly suffered from dyslexia and yet made it “big” in their fields.

Etiology

Genetic predispositions appears to play an important role. First degree relatives with learning disability, prenatal cigarette exposure, lead exposure and PEM are risk factors.

A large proportion of the children have had delayed speech and language development.

There is no organic brain lesion in most of the cases. Likewise, socioeconomical, cultural, environmental and educational factors as also other disabilities are not the primary cause.

Classification

- A. Global: All aspects of learning are affected because of low IQ
- B. Specific
 1. Reading disorder
 2. Mathematical disorder
 3. Disorder of written expression.

Clinical Features

Child's performance remain behind his actual potentials though his intelligence is by and large within normal limits. This results in poor scholastic achievements and even failures. Major manifestations are:

- Difficulties in acquiring and using language:
 - Reading and writing letters in the wrong order.
 - There is directional confusion as well as confusion regarding capital and small letters.
- Difficulties in learning to speak.
- Difficulties in learning letters and their sounds
- Difficulties in memorizing number facts.
- Difficulties in learning foreign languages.
- Difficulties in correctly doing math operations.

Diagnosis

Discrepancy between potential (ability, IQ) and achievement, resulting in underachievement, especially in reading, is the most important clue.

History It should enquire into prenatal, perinatal or postnatal factors contributing to learning disability. Information with respect to marital disharmony, unrealistic expectations from the child, sibling rivalry, discrimination and emotional trauma should be sought.

Physical examination It should exclude any neurological deficit, hearing and visual loss.

Investigations These include screening for hearing, vision, speech and psycho-educational status.

Treatment

A multidisciplinary approach, involving the class teacher, remedial teacher, parents, social worker, pediatrician, psychologist and, if warranted, even a psychiatrist, is important in managing the learning disability. The teaching curriculum is adjusted and specific teaching materials employed to help the child explore his optimal learning potential. For reading disability, the child should be taught:

- to break the spoken words into smaller units of sound
- that letters on the page represent these sounds
- that written words have the same same number and sequence of sounds as heard in spoken words
- Phoneme awareness

Additional helpful measures include:

- Practice in reading stories is useful.
- Computers with spelling checker
- Tape-recorders
- Recorded books
- Oral rather than written examination
- Drug therapy for comorbidity such as emotional problems, hyperactivity and enuresis.

ATTENTION DEFICIT HYPERACTIVITY DISORDER (ADHD)

It is defined as hyperactivity, impulsiveness and inattentiveness inappropriate for age. Boys suffer thrice compared to girls.

Classification

Class I: Hyperactivity, impulsiveness and inattentiveness (most common)

Class II: Hyperactivity and impulsiveness only

Class III: Mainly inattentiveness (uncommon).

Etiology

The cause is not precisely known though brain damage, prematurity, low birthweight, and psychosocial and genetic factors have been blamed. An interaction between biologic (genetic endowment) and psychosocial factors appears to be the cause. Of course, clinical expression is influenced by child's environments. Problems of attention and learning difficulties may well be secondary to frustration.

Diagnosis

It is mainly clinical. At least 6 symptoms of hyperactivity-impulsiveness or inattentiveness are required (Box 5.1). Lead toxicity, IDA, thyroid disorder, CAN, substance abuse (phenobarbital, vigabatrin), mild mental retardation, mood and anxiety disorder, schizophrenia, learning disability, etc should be excluded. Only role of investigations is to rule out other disorders.

Box 5.1: Diagnostic criteria in ADHD**Inattention**

At least six of the following criteria for a minimal of six months:

1. Often fails to give close attention to details or makes careless mistakes in school work or other activities.
2. Often has difficulty in sustaining attention in tasks or play activity.
3. Often doesn't seem to listen when spoken to directly.
4. Often doesn't follow through instructions and fails to finish schoolwork, chores, duties in workplace (not due to oppositional behavior or failure to understand instructions).
5. Often has difficulty in organizing tasks and activities.
6. Often avoids, dislikes, or is reluctant to engage in tasks that require sustained mental effort (such as schoolwork or homework).
7. Often loses things necessary for tasks or activities, e.g. toys, school assignments, pencils, books, tools, etc.
8. Often easily distracted by extraneous stimuli.
9. Often forgetful in daily activities.

Hyperactivity/Impulsivity

At least six of the following criteria for a minimal of six months:

1. Often fidgets with hands or squirms in seat.
2. Often leaves seat in the classroom or other situations in which remaining seated is expected.
3. Often runs about or climbs excessively in situations in which it is inappropriate.
4. Often has difficulty in playing or in engaging in leisure activities.
5. Often "on the go" or acts as if "driven by a motor".
6. Often talks excessively.
7. Impulsivity
8. Often blurts out answers before questions have been completed.
9. Often has difficulty awaiting turn.
10. Often interrupts or intrudes on others, e.g. bursts into conversation or games.

Management**Tutoring**

Management aims at tutoring the child to acceptable behavior and at his training with patience and understanding through behavioral and psychosocial therapy aimed at the child, the parents and the school. The program must involve close coordination among parents, teachers and psychologist.

Pharmacotherapy

Stimulant drugs such as methylphenidate (Ritalin), dextroamphetamine, magnesium pemoline, and tricyclic antidepressants (imipramine, desipramine), alpha-adrenergic agonists (clonidine) and phenothiazines (diphenhydramine, thioridazine) are efficacious and are strongly recommended.

Nonstimulant drug, atomoxetine, has been recommended as a preferred drug for

- Adolescent ADHD and
- ADHD with comorbidities and contraindications to stimulants.

It acts by increasing norepinephrine and dopamine levels, especially in the prefrontal cortex.

Prognosis

Prognosis is favorable, many children doing well in adulthood if they are properly employed. The presence of aggression in childhood is a predictive symptom of adult psychopathy in the form of sociopathy, hysteria and alcoholism.

AUTISTIC SPECTRUM DISORDERS (ASDs)

ASDs/Pervasive developmental disorders (PDDs) include autism, Asperger's syndrome and Rett's syndrome and are characterized by the three major features, namely:

1. Impaired social interaction
2. Impaired communication
3. Impaired imagination.

Asperger's disorder is characterized by impaired social interaction though communication and cognitive function are preserved. The child interacts with others but in an inappropriate way. He approaches others in endless monologues on a topic of interest to him but without appreciating that the other party is disinterested.

Rett's syndrome is characterized by regression of motor milestones and language (after 1 year of age; invariably in females), ataxic gait or fine tremors of hands, sighing respiration with intermittent apneic spells, repetitive hand-wringing movements and autistic behavior. Also, see Chapter 23 (Pediatric Neurology).

Autism is a complex developmental disability appearing in first 3 years of life. It is a sort of poorly understood psychosis in which the child is highly withdrawn and seemingly living in an isolated world of his own with complete failure to react to other people, communication problems, extreme aloofness and obsessive desire for sameness in routine and surroundings. In addition, there may be mental retardation, seizures or learning disabilities. Autism is not caused by bad parenting.

The following details pertain to autism.

Epidemiology

Prevalence of classical autism is estimated to be around 4-5 in 10,000 population. Most cases are first born or late born (fourth or more in sibling rank). Boys suffer more often than girls.

Etiology

Various hypothesis about its etiology include:

- Genetic predisposition in view of its occurrence in pairs of identical and fraternal twins. Susceptibility locus is on long arm of chromosome 13 and 17.
- Neurologic theory in the form of damage to reticular formation of brainstem about fifth week of intrauterine life (rubella), leading to "a window of vulnerability" for autism.
- Organic theory, based on abnormal brain rhythms in EEG, blames a neurologic dysfunction (PKU, infantile spasms, herpes simplex encephalitis) as the cause of autism.
- Psychological theory that totally blames parents for autism in the child is not widely accepted

Clinical Features

The autistic child may have an organic brain disease as in blindness, deafness or mental retardation, or from emotional deprivation. He may, however, be of normal intelligence, some gifted with "islands of brilliance". The child's potential is masked and not low or absent.

The child takes no interest in environments and is negativistic. He fails to develop normal relationship with others, including his mother, and does not react to a situation in an expected manner. Lack of eye contact, facial expression and gestures is missing. Speech is either poorly developed or not developed at all. About 60% patients develop highly individualized language. They insist on following same routine everyday. Some children may be attracted by spinning or rotating objects. Response to stimuli may also be unusual.

Seizure are more likely in autistic children.

Diagnosis

Early identification, based by and large on clinical grounds, is of paramount importance. Role of investigation is limited to determining the existence of predisposing or accompanying factors.

Management

General

The cornerstone of management is to establish contact and communication with the child so as to prevent him from sliding into utter isolation. Providing a structured predictable environment employing play, language therapy and interpersonal exercises helps. It should revolve around the following three strategies:

1. Management of abnormal behavior (behavior modification)
2. Help for the family
3. Arrangements for educational and social services.

Pharmacotherapy

There is no medication to treat autism as such. However, specific symptoms (aggression, temper tantrum) may warrant medication. Neuroleptics (olanzapine, risperidone), dopamine antagonists (haloperidol) may be selectively employed to relieve comorbidity.

Prognosis

Prognosis is guarded. Only a small proportion of the children grow up to acquire language and social skills and have self-sufficient (independent) existence in the community. Most end up in institutions sooner or later.

ENURESIS (BEDWETTING)

The term, enuresis, denotes normal urinary bladder emptying at a wrong place and time at least twice a month after the age of 5 years.

Nocturnal enuresis refers to bedwetting. It is a fairly common pediatric problem, occurring in about one-fourth of children, and is a potential cause of embarrassment to the child as well as the parents. A proportion of the children suffering from this disorder may wet their garments during waking hours as well. Boys suffer more often than girls. Remarkable familial pattern is observed.

Clinical Features

Two clinical types are recognized: primary (persistent) and secondary.

In the *primary (persistent) enuresis*, the child has never been dry at night. It is usually the result of erratic bladder training either by parents who are overanxious

1 for prompt control, or those who are not reasonably close to the child's needs, or chronic psychological stress not related to bladder training.

Secondary (regressive) enuresis is characterized by initial control of bladder that later gets disrupted by stressful environmental events like marital conflict, death, arrival of a sibling, or shifting to a new house. It is usually intermittent and transitory.

Four types are recognized based on daytime symptoms:

- Type I: Monosymptomatic nocturnal enuresis
- Type II: Diurnal enuresis without daytime frequency
- Type III: Nocturnal enuresis with daytime frequency
- Type IV: Nocturnal diuresis with daytime frequency and voiding dysfunction

Etiology

The causes are:

- i. Psychologic enuresis may be a manifestation of family conflict and maladjustment, e.g. too strict parents, rejection, sibling rivalry, etc. An erratic handling of the problem by the parents causes further anxiety to the child. His condition, therefore, gets more aggravated,
- ii. Too late, too early or improper training by the parents regarding the bladder control is also an important factor in the causation of bedwetting.
- iii. Physical factors like threadworm infestation, genitourinary infections, anatomic defects, etc. may be responsible for enuresis in some cases.

In both types (primary and secondary), an organic pathology is present in less than 5% cases. Dysuria, frequency, straining, dribbling, gait disturbances and poor bowel control suggest an underlying organic cause.

Diagnosis

This should include a detailed interview with the parents as well as the child to find the etiologic or, at least, associated emotional factors, together with a complete physical examination. Intestinal parasitosis, especially threadworm, genitourinary infection and anatomic defects should be excluded.

Urine analysis and urine culture should be performed at the initial visit to exclude UTI. An X-ray

of lumbosacral spine, ultrasonography, voiding cystourethrogram and urodynamic studies are often required.

Treatment

A prompt treatment is essential or the child may continue to have enuresis plus added emotional problems in adolescence. Treatment is, as a rule, not required before 6 years of age.

If the underlying disease is detected it should be treated.

In others, treatment consists of:

- I. Psychotherapy and training (behavior modification) in the form of:
 - a. Reassurance to the parents and the child. Parents should be told to encourage the child in having dry nights. In fact, they should offer special pat and even reward on occasions when the child does not wet the bed.
 - b. Restriction of too much of water and drinks at bed time and insisting on his voiding before retiring.
 - c. Waking him up once or twice to void during night.
 - d. Rewarding the child for the dry nights (which should be charted on a calendar) assists in enlisting the cooperation of the child.
 - e. Discouragement of punishment or humiliation of the child by the parents.
 - f. Ridicule by siblings and friends should not be allowed. Parents need to spend at least half an hour of quality time with the child.
- II. Bladder-strengthening exercises. This include emptying the bladder before sleeping, drinking large quantity of water during daytime and holding urine as long as possible i and practise repeatedly starting and stopping the stream in the flush.
- III. Using an electric alarm (buzzer) device which is designed in such a way that the child wakes up as soon as he is about to wet the bed. The device is based on the condition reflex response. It consists of a sensor fixed to child's underwear and an alarm placed at bedside.
- IV. Drugs
Imipramine hydrochloride, 0.9 - 1.5 mg/kg/day (O) at bedtime for 3-6 months, gives good results. It acts by altering the arousal-sleep mechanism. The success rate considerably improves if it is supplemented with a small dose of diazepam.

Anticholinergic agent, oxybutinin, 10-20 mg/day (O), for 3-6 months, is useful for daytime enuresis with urgency and urge incontinence. It acts by reducing the uninhibited bladder contractions.

Desmopressin(DDVPj, which is a synthetic antidiuretic agent, is a relatively expensive modality for enuresis. The basis for use of this drug is that immediate triggering factor for enuresis is the overdistended bladder resulting from reduced secretion of the ADH rather than the abnormal bladder capacity or function. It is given in full dose (10-40 meg/day) as spray until child is dry for 28 successive nights. Thereafter, dose is tapered over 3 weeks period.

At times, a combination of modalities (say electric alarm device plus drug therapy) works best.

The pediatrician must also develop a positive relationship with the child to allay feeling of guilt, resentment or shame. He should motivate the child for "independent control".

CEREBRAL PALSY (CP)

CP is a form of chronic motor disability which is nonprogressive, nonfatal and yet noncurable and results from damage to the growing brain before birth, during birth, or after birth. Convincing evidence is now available to show that birth asphyxia, earlier believed to be a leading cause of CP, is, in fact an uncommon etiologic factor in this entity. Current thinking is that

roots of pathogenesis of CP may well be in the developmental biology. For details, see Chapter 23 (Pediatric Neurology).

BEHAVIORAL PROBLEMS

See Chapter 6 (Child Psychiatry and Behavioral Problems).

FURTHER READING

Articles/Chapters

1. Greydanus DE, Pratt HD. Attention deficit hyperactivity disorder. In Greydanus DE, Patel DR, Pratt HD (Eds): *Behavioral Pediatrics*, 2nd edn. New York: Universe 2006:107-142.
2. Kalra V, Seth R, Sapra S. Autism: Experience in a tertiary care hospital. *Indian J Pediatr* 2005;72:227-230.
3. Mikkelsen EJ. Enuresis and encopresis. Ten years of experience. *J Am Acad Child Adolesc Psychiatry* 2001;40:1146.
4. Unni JC. Drug therapy: Atomoxetine. *Indian Pediatr* 2006;43:603-606.
5. Veenstra-Vanderweele J, Cook E. Genetics of childhood disorders: Autism. *J Am Acad Child Adolesc Psychiatry* 2003;42:116-118.

Books/Monographs

1. Gupte S. *Recent Advances in Pediatrics (Special Vol 19: Developmental and Behavioral Pediatric)*. New Delhi: Jaypee 2007.
2. Thacker N. Autism Spectrum disorder. *Indian Pediatr* 2007;44:251.

CHAPTER



Child Psychiatry and Behavioral Problems

Suraj Gupte, Tejinder Singh

INTRODUCTION

The field of *child psychiatry* primarily deals with identification and handling of the emotional, behavioral and developmental disorders of childhood. Its knowledge in case of a pediatrician is of particular importance, at least for two reasons. *First*, his first contact with the child and his parents and the subsequent contacts uniquely contribute to evaluating the development of the child and advising the parents about his upbringing. *Secondly*, it is vital for him to identify psychosocial or psychotic problems not only for managing these but also for seeking psychiatric consultations as and when indicated. Symptoms in childhood psychiatric disorders are subtle and are likely to be passed off as normal variants. Even in frank cases, parents are reluctant to consult a psychiatrist due to social taboos. No doubt, the field of child psychiatry helps him to understand the child through and through as a living, acting, feeling, and choosing being. He is unlikely to fulfill this function completely and earnestly without the knowledge of fundamentals of child psychiatry.

PSYCHIATRIC DISORDERS: AN OVERVIEW

Classification of psychiatric disorders in children remains debatable. The following classification represents the current state of consensus among the pediatricians and psychiatrists actively involved in the field:

- Adjustment reactions
- Behavioral problems

- Special Symptoms
- Childhood neurosis
- Childhood psychosis
- Organic brain syndrome
- Mental retardation

The term, *adjustment reaction*, is applied for the disorders that are benign and temporary-developmental maladjustments which regress with proper care and support. Transient feeding problems, disobedience, stealing, lying or truancy are some of the examples of adjustment reactions. The cause is usually a disturbed family relationship

The term, *behavioral problems*, refer to disorders that represent significant deviation from the normal behavior (vide infra).

The term, **neurosis**, means disorders that have anxiety and distress as common denominators. Neurosis has a clear onset and is somewhat more severe and pathologic than the so-called "adjustment reactions" already defined. It is classified as anxiety neurosis, depressive neurosis, hysterical neurosis, phobic neurosis (school phobia, fear of an external object or situation), and obsessive-compulsive neurosis.

In **psychosis**, a serious and presumably organic brain disorder, there is clearcut loss of contact with reality. It may be of early onset (infantile autism, pervasive developmental disorder) or late onset (childhood schizophrenia, symbiotic or interactive psychosis).

The term, **organic brain syndrome**, denotes disordered functioning of personality affecting the individual's subjective life or his relations with others

as well as his capacity to adapt to society. There is always an organic diffuse involvement of the brain. The so-called “attention deficit hyperactivity disorder” (ADHD), earlier called “minimal brain damage (MBD) syndrome”, belongs to this category.

Mental retardation is characterized by limitation in performance that follows considerable impairment in measured intelligence and adaptive behavior. Children with an IQ of less than 83 fall under this heading. For details see Chapter 23 (Pediatric Neurology).

Under ideal conditions, the best place for arriving at the exact diagnosis and treating such problems is the *Child Guidance Clinic*. But, such facilities may not be available to most of the emotionally disturbed children in developing countries like India. It is, therefore, desirable that all doctors dealing with children should have working knowledge of these problems.

No doubt, the best way to treat a child with psychosomatic problem is to have an understanding of his family and interaction between him and the significant persons connected with him. Though child is treated through psychotherapy and playtherapy, his parents must actively participate in the management. In fact, in many instances, it is the parental end that is in real need of counseling.

BEHAVIORAL PROBLEMS

Behavioral problems include disorders that represent significant deviation from the normal behavior. These disorders are relatively stable, internalized and difficult to treat than the adjustment reactions but less so than neurosis and psychosis. The hyperkinetic reactions, runaway reactions and group delinquency are examples of behavioral disorders. The root of the problem usually is traceable to the home and/or the school environment.

When the parents report a solitary symptom in the absence of any other major illness in the child, it is classified as *special symptom*. Common examples of this category are nail biting, thumb sucking, somnambulism and enuresis.

Since, a situational aberration (usually in the family or at school) is a common denominator of the background of adjustment reactions, behavioral problems and special symptoms, it is customary to label all these as “behavioral disorders”.

Table 6.1 lists the common behavioral disorders according to nature of deviation in behavior and Table 6.2 according to age of occurrence of the disorder.

Factors contributing to behavioural problems are given in Table 6.3.

The etiology of behavioral disorders is multifactorial, including maladjustment at home and/or school, and factors operating before pregnancy, during pregnancy, during delivery and in neonatal period. A faulty emotional environment (constituted by parental attitudes, siblings, neighborhood, school and mass media, including tele-vision, radio and periodicals) is, however, most important.

Table 6.1: Categorization of common behavioral problems

Habit problem

Thumb sucking, nail biting, tics, enuresis, encopresis trichotillomania, breath-holding, aerophagia

Problems of eating

Pica, food fads, food refusal/overeating, vomiting, aerophagia, anorexia

Sleep problems

Night terrors, nightmares, somnambulism, insomnia, sleep-talking, hypersomnia, narcolepsy, cataplexy

Speech problems

Stammering, stuttering, mutism, phonation and articulation disorders

Scholastic problems

Reading, writing or mathematical disability, repeated failures, absenteeism, truancy, school phobia, aggressiveness

Sexual problems

Masturbation, homosexuality, incest, precocious sexuality, hypersexuality

Personality problems

Shyness, timidity, fears, anger, jealousy

Antisocial problems

Juvenile delinquency in the form of stealing, lying, destructiveness, cruelty, gang activities, etc.

Table 6.2: Categorization of behavioral problems in relation to age group

Infancy

Feeding problem, colic, stranger anxiety, breath-holding spells, temper tantrum

Preschool age

Head banging, body rocking, thumb sucking, nail biting, masturbation, lack of clarity of speech

Midchildhood

Stuttering, pica, sleep problems, enuresis, encopresis, tics

Adolescence

Juvenile delinquency

Table 6.3: Factors associated with behavioral problems

Child	Health Development
Parents	Coping mechanism Misinterpreted behavior Mismatched expectations Parenting style
Environment	Coping mechanism Stress Support

Of the environmental factors, faulty parental attitudes (rejection, overprotection, dominance, unrealistic expectations, overcriticism, discrimination, unfavorable comparison, over or underdiscipline, dominance by the parents, marital disharmony, etc.) are the single most vital cause of behavioral difficulties.

Overprotection means more than excessive protection of the child against danger with the result that he is not allowed to take care of himself and grow up like his peers who are given balanced protection. It may happen in the only child, the only son in particular, a child born after many years of waiting, the first born, especially in a joint family, a very good-looking child, a mentally retarded or physically handicapped child, in case of loss of a spouse or failure on the part of the spouse to play his or her role well, or a child who is supposed to have brought fortune to the parents.

Rejection, on the contrary, usually is accompanied by failure to attend to the normal needs of the child, unfavorable comparisons, admission to an institution when the circumstances do not really demand it, unnecessary scolding, excessive punishment, or failure to please the child consistently with a reward as and when appropriate. There is invariably accompanying favoritism to the other-child. Rejection may happen in an unwanted child, an illegitimate child, a stepchild, a mentally or physically handicapped child, a child who is supposed to have brought bad luck to the family, or a child who is chronically mischievous and (a constant source of troubles for the family).

Not infrequently, parental attitudes may well be a cocktail of overprotection and rejection at different times, depending on such diverse factors as parents' mood, financial position, job satisfaction, and interparental relationship. Lack of consistency on the part of the parents confuses the child, leading to conflict, anxiety and insecurity.

PICA (*Geophagia*)

The term, *Pica* (Latin: magpie), refers to eating of substances other than food (nonedible items), e.g. earth, dust, clay, sand, flakes of paint, plaster from wall, fabrics, ice (*pagophagia*), etc. It is frequent in first 4 years of life but may be seen in grown-ups as well. Pica as a manifestation of inclination for mouthing and tasting in the absence of any associated problem may be taken as normal until 2 years of age. Thereafter, it may well be considered a deviant behavior requiring attention.

Etiology

Association of pica with mental retardation is a category *per se*. Here we are concerned with pica in otherwise normal children.

In the latter situation, pica usually occurs in children from lower strata of society with suggestions of parental neglect, poor supervision or proper attention. Associated malnutrition with worm infestation and vitamin and mineral deficiencies is common. Whether these are the cause or effect of pica remains unsolved.

Clinical Features

These infants and children are often anemic (primarily because of IDA) and have mineral and vitamin deficiencies. Intestinal parasitic infestations are generally associated. Some develop pseudotumor cerebri. Besides, there is a risk of chronic lead poisoning which can be dangerous. Also, behavioral problems are common. Some children may pull out their head hair (*trichotillomania*) and swallow them. Lots of hair may collect in the stomach which becomes palpable as a big lump in the upper abdomen (*trichobezoar*), particularly after meals. The perverted appetite in such children is generally a manifestation of psychologic cause which should be searched.

Treatment

In view of the common association between pica and worm infestation plus vitamin and mineral deficiencies, it is necessary that treatment of these factors receives attention at the earliest.

Psychotherapy is of value in cases where pica is associated with psychosomatic problems.

ANOREXIA NERVOSA AND BULIMIA

See Chapter 5 (Developmental Disorders).

ENURESIS (Bedwetting)

See Chapter 5 (Developmental Disorders).

ENCOPRESIS

Encopresis, indicating a more serious emotional disturbance than enuresis, is characterized by passage of feces into inappropriate places at any age (usually after 5 years) when bowel control is expected to be accomplished.

In primary encopresis, chronic soiling persists from infancy onward. In secondary (regressive) encopresis, soiling occurs after attaining bowel control at appropriate age. Accompanying symptoms include chronic constipation, fecal impaction, overflow incontinence, and poor school attendance and performance.

The cause is subconscious anger and defiance in the child. Children with autism are more likely to have encopresis.

Treatment is similar to that of enuresis as far as supportive measures are concerned. Primary encopresis is more difficult to treat than the secondary form. Hirschsprung's disease is considered in the differential diagnosis of encopresis.

SLEEP WALKING (Somnambulism)

"Loafing" around aimlessly during sleep is, by no means, rare in childhood. According to one estimate, somnambulism occurs in about 5 to 8% of children. Such children are aware of the environment during the episode but are indifferent to it. They resent all attempts to arouse them during the act.

Once awake, they remember almost "nothing" about the episode.

There are several familial instances of somnambulism. This author knows of a family in New Delhi with the twins, their father and an uncle—all suffering from this disorder.

Preventive measures include "locking the doors and windows, removing dangerous objects and correction of superstitions". Small doses of diazepam are of value in advanced cases.

BREATH-HOLDING SPELLS

This common situational disorder, also known as *infantile syncope*, accounts for 4 to 13% of psychosomatic disorders in pediatric age group. The condition occurs to some degree in up to 27% of otherwise normal children. In a vast majority, onset is before 18 months of age.

Two types are recognized: pallid and cyanotic. Cyanotic type is thrice as frequent as the pallid type. In 20% of cases, both types may coexist.

Etiology

The time-honored belief is that breath-holding spells result from frustration. A disciplinary conflict between parents and the child is the basic underlying cause. The child uses the attack or its threat to "assert" himself and to express his anger or protest.

According to a recent explanation, genetically determined dysregulation of autonomic nervous system reflexes is responsible for BHSs. Different autonomic dysregulatory mechanisms are responsible for the two types of BHSs. The *pallid type* is supposed to be secondary to cardiac asystole, similar to a vasovagal attack. It can be induced by ocular compression. The *cyanotic type* results from a rise in intrathoracic pressure when breath is held in expiration (as, for example, during crying), leading to decrease in cerebral circulation. The mechanism involves an interplay among hyperventilation, Valsalva maneuver, expiratory apnea and intrinsic pulmonary mechanisms. Cerebral anoxia from an autonomic dysfunction is responsible for loss of consciousness. Though the beginning of the attack is voluntary, subsequent loss of consciousness is involuntary.

Role of iron deficiency anemia (IDA) too is speculative. The association between BHSs and IDD is well known. Anemia seemingly adversely affects the compensatory functions of autonomic nervous system and contributes to cerebral anoxia in severe BHSs. Treatment of IDA in many of them may promptly and fully stop the spells.

Clinical Features

In a classical attack, the child cries, hyperventilates and holds his breath (usually in expiration) followed by

1 cyanosis in a few seconds. There may occur momentary loss of consciousness and convulsive twitchings. Finally he becomes limp.

In second type, the child develops characteristic pallor rather than cyanosis.

The first type is called *cyanotic* and the second *pallid*.

The onset in both the types is between 6 and 18 months of age. The frequency is usually one to three attacks a day.

Diagnosis

Clinical picture is usually so characteristic that little difficulty should be encountered in recognizing the condition. When "spells" are accompanied by tonic and clonic convulsions, differentiation from epilepsy becomes essential. In the former, an obvious precipitating factor can invariably be elicited. Secondly, cyanosis in spells precedes convulsions whereas in epilepsy it follows these. Thirdly, EEG in spells is invariably normal.

Breath-holding spells should also be differentiated from cyanotic attacks seen in congenital heart disease.

Treatment

It is directed at determination of the causative and precipitating factors and treating these by psychotherapy. Drug therapy is of insignificant value. Attention must be directed to coexisting iron deficiency anemia, if any, and prompt treatment offered for its correction.

Very frequently occurring pallid BHSs may respond to atropine sulfate, 0.01 mg (O) thrice daily.

Response to piracetam, an expensive agent, too is quite gratifying.

Prognosis

As the child grows, frequency of spells decreases. Finally, almost all such children are symptom-free by the age of 5 or 6 years.

Incidence of temper tantrum and other behavioral disorders in these children is high. There is no evidence that epilepsy occurs in greater proportion in them than in the normal population

THUMB SUCKING AND NAILBITING

These are very common problems. Over 20% children are known to exhibit these sooner or later.

Thumb sucking beyond the age of 3 years may adversely affect the teeth in a proportion of children. .

Nail biting is a phenomenon demonstrated by children beyond 4 years of age. It may continue up to adolescence and even in latter life.

The cause is a kind of insecurity, a conflict or hostility. The child seemingly draws a sense of pleasure from such self-stimulations.

Treatment consists in reassurance to the parents and guidance that they need not be "fussy" over these benign problems.

TEETH GRINDING (*Bruxism*)

Teeth grinding among children, especially during sleep, is a common observation. In case of infants, one need not bother about it. In older children, it may be a manifestation of disturbing dreams, pent-up tension and aggression. Apart from this, bruxism may occur in mental retardation and in unconscious patients, more so those suffering from meningitis or encephalitis. There is no evidence that bruxism has any relationship with worm infestation.

Treatment consist in improving the environmental situation responsible for the tension and conflict. Attempts should be made to make bedtime more enjoyable and relaxed. Watching of thrillers and horror shows at bedtime should be avoided.

STUTTERING

Preschoolers, generally between 3 to 5 year of age, may start stammering. The cause in a large majority of the cases is the neurotic attitude of the mother.

It is an indication of a conflict in child's personality.

No treatment is generally needed. If stuttering persists, breath-control exercises and miniaturized metronome that is of value in pacing the rhythm of speech need to be resorted to under care of a speech therapist.

TICS (*Habit Spasm*)

The term refers to fast repetitive movements which are frequently stereotyped and are alterable at will.

Tics occur most often in school-going children and usually represent emotional disturbance or mal adjustment. Generally, they may be an outlet for the suppressed anger and worrysomeness following control of aggression by the parents or the teacher.

A kind of tics in which extensive and varied bodily movements are accompanied by vocalization (barking or shouting obscene words) has been termed Gilles de la Tourette syndrome.

Severe variety of tics requires psychiatric evaluation. In Tourette syndrome, 1 to 5 mg haloperidol, given orally daily, as such or together with an antiparkinsonian drug, is indicated.

SCHOOL PHOBIA

(School Refusal, School Withdrawal)

School phobia refers to absolute refusal by the child to go to school.

The major underlying factor is anxiety about separation from the parents, most often the mother. The parents are responsible for giving the child an impression that school is a place to be dreaded and that they won't indeed mind his staying at home. There usually is a far-too-close tie between the child and the parents. The mother is overindulgent, overprotective and domineering type and the father is ineffective and disinterested.

Such school factors as bullying or teasing, unreasonable punishment or dislike of the teacher may also contribute to the problem.

Treatment consists in weaning the child and the parents from each other with the help of a child psychiatrist and family physician. The cooperation of the school teacher(s) should be obtained as and when warranted.

DRUG ABUSE *(Substance Abuse)*

Drug habit is no longer a "rarity" among the adolescents of developing countries. All India surveys indicate as high an incidence as 3% of "addiction" and 15% of "casual indulgence" among senior school-going students. The prevalence is particularly high in boarding public schools.

The drugs generally abused are alcohol, tobacco, sleeping pills, tranquillizers, central stimulants, mood-elevators, cannabis (bhanga, charas, ganja) and opiates. LSD, cocaine and heroin are used by a much smaller proportion of abusers. The majority use more than one drug.

Most of the addicts show significant evidence of conflict, confusion, mental tension and remarkable deterioration in academic performance. Shoplifting,

stealing and, at times, even trafficking are resorted to by the "diehard" addicts to make enough money for procuring their supply of drugs.

Why drugs? The causes include frustration at home, a poor performance at school, bad company and emotional stress. "Keeness to burn midnight oil" at the time of examination and to "gear up stamina" for better performance in sports and athletics are said to be the stimulus to take drugs with some. Others indulge in the word of drugs "just for kicks", "just for the heck of it", "simply to see what will happen" or as an "adventure". Yet another group consumes drugs to "hit back" at the parents, teachers or society-in protest indeed.

To check the malady, the recommended measures include:

1. Provision of adequate facilities for recreation and entertainment, especially in the hostels.
2. Proper channelization of energies of the adolescents into constructive activities.
3. Inculcation of the dangers of drug abuse among students, their teachers and family members.
4. Provision of periodical psychiatric guidance facilities in schools.
5. Strict implementation of drug control measures.

Also see Chapter 4.

PERIODIC SYNDROME

The disorder refers to periodic occurrence of certain symptoms such as colicky abdominal pain (periumbilical) nausea and vomiting, headache (often of migranous variety), diarrhea or constipation, marked pallor or flushing, fever and prostration. These manifestations may be present in various combinations.

A characteristic feature of the syndrome is that recurrences occur at different periodicity of weeks or months. In between the attacks, the child is all right.

The patients are usually emotional, highly strung, obsessional and perfectionists. Their parents' "expectations" are far too lofty. A quarrel in the family or school examination often precipitates the attack. There is, as a rule, no evidence of infection. In a small proportion, there may be evidence of epilepsy.

Treatment consists in providing assistance with emotional stress in the family or school. Regular psychotherapy may be warranted in "hard" cases.

1 **HYSTERIA** (*Hysterical Conversion Reaction*)

In hysteria, now recognized as a dissociative (conversion) disorder, the child (usually a preadolescent or an adolescent) with a psychopathic personality presents with manifestations simulating an organic disease, say recurrent abdominal pain, sensation of compression of the throat (globus hystericus), blindness, gait disturbances, paralysis, sensory loss, urinary retention, seizures or dyspnea.

A good history-taking and clinical workup usually lead to the correct diagnosis without resorting to painstaking investigations. The patient has a tendency to be indifferent to the queries and relates manifestation in a detached manner.

Common Presentations

Hysterical seizures, a common presentation, are remarkable by absence of tongue-biting, apnea and incontinence. The patient tends to forcibly hold the eyes closed and seizure activity is bizarre. Quite often, seizures are marked by rhythmic thrusting and writing of trunk. Nocturnal seizures, stereotyped aura, cyanotic skin changes and postictal confusion are infrequent in pseudo-seizures seen in hysteria. Moreover, serum prolactin level remain normal after the pseudoseizures. EEG too shows no spike and wave forms or postictal slowing.

Hysterical blindness is characterized by tunnel vision and absence of pupillary abnormality and fundoscopic abnormality.

Hysterical ataxia is characterized by inability to stand or walk without any deficit on neurologic examination when tested in lying position. The gait is bizarre and there is extreme lurching on the sides. In cerebellar ataxia, on the other hand, the patient walks on a wide base and has difficulty in maintaining balance.

Hysterical paralysis is characterized by presence of normal muscle tone, tendon reflexes and plantars, and positive Hoover test. The last-named consists in keeping hand under the allegedly paralysed leg and asking the patient to raise the normal leg against resistance. As the patient forcefully lifts the leg, the examiner's hand can feel downward pressure of the affected leg against the examiner's hand. This occurs only in hysteria.

Hyperventilation syndrome is a state characterized by dyspnea, tightness or stabbing pain in chest,

headache, abdominal pain, muscle pains, paresthesia, palpitations, dryness of mouth, vertigo, choking, weakness, blurred vision, confusion and syncope. The syndrome occurs in episodes. The causes include acute anxiety state, uremia, salicylate poisoning, hypernatremic dehydration, diabetic ketoacidosis, and Reye syndrome. Treatment is primarily of the cause.

Management

Treatment of hysteria is primarily early detection and symptom removal. The symptom removal (normalization) can be attained by insisting on adherence to routine and contracting differential reinforcing and removal of secondary reinforcers. The child should never be accused of feigning the symptoms. Appropriate antidepressants and anxiolytics may be warranted.

ATTENTION DEFICIT HYPERACTIVITY DISORDER (ADHD)

See Chapter 5 (Developmental Disorders).

AUTISM

See Chapter 5 (Developmental Disorders).

CHILD ABUSE AND NEGLECT

Maltreated and abused children may suffer from such emotional problems as fearfulness, low self-esteem, juvenile delinquency, substance abuse, hyperactivity, aggression, denial, lack of trust, projection, hyper-vigilance, etc. In the long run, they may end up as delinquent, violent and antisocial adults and potential child abusers. For details, see Chapter 42 (Miscellaneous and Unclassified Issues).

PRINCIPLES OF COUNSELING IN BEHAVIORAL DISORDERS

According to the dictionary, "counseling means providing of advice and guidance to a patient by a health professional."

It is a useful intervention for many behavioral disorders, aiming to affect a change in behavior. To be of real benefit, the change should be learnt and not imposed. Paradoxically, however, the intended change in behavior is often imposed on children and/or parents. Hence, high chance of failure. Secondly, while counseling for a change in behavior, any attempt at

invoking a guilt feeling should be avoided. Once the intended behavioral change is learnt, it needs to be reinforced to make it permanent. Spending 15-30 minutes daily for a positive child-parent interaction is useful. Generally speaking, mothers are expected to perform this role. However, it is desirable that the father too take interest and responsibility in this pursuit. After all, often the unresolved conflicts in the child relate to the relative role played by both parents.

Counseling should also aim at diffusing the guilt feeling in parents. Among others, the following two approaches are helpful in this behalf.

- Bringing to their knowledge the cases of many other parents with similar problems and providing guidelines for coping with them.
- Increasing the support circle, e.g. letting several mothers with enuretic children discuss the problems among themselves.

FURTHER READING

Articles/Chapters

1. Choudhry RK, Gupte S, Agarwal MM. Somnambulism. *Indian J Psychiatr* 1978;23:274-276.
2. Dutta S. Hysteria. In Gupte S (Ed): *Recent Advances in Pediatrics-10*. New Delhi: Jaypee 2000:163-174.
3. Garg RK. Breath-holding spells. In Gupte S (Ed): *Recent Advances in Pediatrics- 10*. New Delhi: Jaypee 2000:119-125.
4. Gupte S (Ed). *Differential Diagnosis in Pediatrics*, 5th edn. New Delhi: Jaypee 2008.
5. Gupte S (Ed). Pica. *Indian Pdiatr* 1982;19:1044-1045.
6. Jaykar AV, Raghuvveera K. Enuresis. In Gupte S (Ed): *Recent Advances in Pediatrics, (Special Vol. 2 Tropical Pediatrics)* New Delhi: Jaypee 1998:210-232.

Book/Monograph

1. Gupte S. *Recent Advances in Pediatric (Special Vol 19: Developmental and Behavioral Pediatrics)*. New Delhi: 2008.

CHAPTER



Adolescence

Suraj Gupte, AK Sahni

INTRODUCTION

Adolescence is the phase, usually between 10 to 20 years, in which children undergo rapid changes in body size, physiology and psychological and social functioning. All body dimensions, development and maturation are completed. This is the net result of hormones and social structures designed to foster the transition from childhood to adulthood.

Adolescence begins with the onset of puberty, defined by the UNICEF as “the sequence of events by which the individual is transformed into a young adult by a series of biological changes”. It is during this period that secondary sex characteristics develop. These sex characteristics have been rated into five stages by Tanner and termed *Tanner’s Sexual Maturity Rating (SMR)*. Globally a secular trend is being noticed towards earlier puberty. What indeed constitutes end of puberty remains controversial.

Arbitrarily, adolescence is divided into three phases: early, middle and late adolescence. Early adolescence refers to age 10 to 13 years, middle adolescence to 14 to 16 years and late adolescence to 17 to 20 years.

Until recently, the adolescent remained neglected by the medical profession as neither the physicians for adults nor the pediatricians looked after his problems. He, in actuality, appeared to be no one’s responsibility, especially in India and other developing countries. Now, of course, thanks to the concerted efforts of the World Health Organization (WHO) and the UNICEF, a worldwide campaign has begun to focus attention on adolescence. In India, for example, the Indian Academy of Pediatrics (IAP) took lead in focusing attention on adolescence by declaring the year

2000 as the *IAP Year of the Adolescent* and the August 1 every year as the *Teenager Day*. According to the IAP, health problems of children up to 18 years (inclusive) should be the responsibility of pediatricians.

In United States of America, pediatrics includes individuals up to the age of 21 years. UNICEF is contented with “up to 18 years” as the pediatric age group. According to the World Health Organization (WHO), adolescence is the period of life that extends from 10 years to 19 years. The IAP defines adolescence as the period of life between 10 and 18 years (inclusive). All these definitions may well be all right for statistical convenience rather than for biological accuracy.

SPECIAL FEATURES OF THREE STAGES OF ADOLESCENCE

1. *Early Adolescence (10-13 years’)*: Growth spurt and secondary sex characters
2. *Mid Adolescence (14-16 years)*: Separate identity from parents, new rapport with peer groups and opposite sex and experimentation
3. *Late Adolescence (17-20 years)*: Established adult physical characters, distinct identity and opinions and ideas.

Table 7.1 summarizes the developmental characteristic of three phases of adolescence.

PUBERTY CHANGES (*Changes during Adolescence*)

Morphological Changes

Morphological changes revolve round rapid and final growth spurt and development of secondary sex characters.

Table 7.1: Developmental characteristics of three phases of adolescence

Characteristics	Early adolescence	Middle adolescence	Late adolescence
Age (years)	10 to 13	14 to 16	17 to 20
SMR	1 to 2	3 to 5	5
Somatic development	Secondary sex characters, onset of rapid growth, awkward	Height growth peaks, body shape and configuration change, acne appears, menarche, spermarche	Slower growth
Sexual development	Sexual interest much more than sexual activity	Sexual drive surges, experimentation, questions of sexual orientation	Consolidation of sexual identity
Cognitive and motor absolutism development	Concrete operations, conventional morality	Appearance of abstract thoughts, self-centered, questioning more	Idealism,
Self-concept	Preoccupation with changing body, self-conscious	Concern with attractiveness, increasing introspection	Relatively stable body image
Family independence, secure base	Struggles for greater independence	Struggles for acceptance of greater autonomy	Practical family remains
Peers Possicommittment	Same sex groups, conformity, cliques	Dating, peer group less important	Intimacy
Relationship to society	Middle-school adjustment	Gauging skills and opportunities	Career decisions (dropout college, work)

Order of Morphological Changes in Girls

- Accelerated gain in weight and height
- Breast changes like pigmentation of areola and enlargement of breast tissue and nipple
- Increase in pelvic girth
- Appearance of pubic hair
- Activity of axillary sweat glands
- Appearance of axillary hair
- Onset of menstruation (menarche). The first bleed occurs usually 2 years after the first manifestation of puberty
- Abrupt slowing of gain in height.

Order of Morphological Changes in Boys

- Accelerated gain in weight and height
- Enlargement of external genitalia
- Appearance of pubic hair followed by hair in axilla, upper lip, groin, thigh, and between pubis and umbilicus. Facial hair appear about 2 years after the pubic hair
- Changes in voice
- Nocturnal discharge of seminal fluid
- Abrupt slowing in gain in height.

Tanner's sexual maturity rating (SMR), which quantifies sexual growth from 1 to 5 is listed in Table 7.2. In case of boys, genitalia and pubic hair and in case of girls genitalia and breasts are prime considerations. No sexual growth (prepubescent stage) means SMR 1 whereas full sexual growth means SMR 5.

Puberty spurt is a remarkable feature of puberty. As much as 50% of the adult weight and 25% of the adult height are attained during this period of life. No doubt, there is a wide variation in the age of onset as also the rate of puberty spurt. Major weight gain in boys is because of dominant muscular development. In girls, fat deposition in characteristic female distribution is responsible for it. Table 7.3 summarizes the three phases of growth spurt.

Psychological Changes

Psychological changes include development of "identity" different from parents, self-esteem, new relationship with peer groups, opposite sex, community, exploration of own and other's bodies as also potentials, and experimentation with risks such as speedy driving, drug abuse, particularly under influence of electronic and other media and peers.

Table 7.2 Tanner's sexual maturity rating (SMR)**Pubic hair stages for boys and girls**

- PH-1 Preadolescent, no pubic hair
 PH-2 Sparse growth of long, pigmented hair at base of penis (boys) and bilaterally along medial border of labia (girls)
 PH-3 Hair, which begin to curl and develop increased pigmentation, spread laterally in boys and over mons pubis in girl.
 PH-4 Hair become coarse and involve more area
 PH-5 Hair spread to medial side of thigh.

Genitalia stages for boys

- G-1 Testes, scrotum and penis of small size
 G-2 Testes and penis slightly enlarged, scrotum develops red hue
 G-3 Testes, scrotum and penis further enlarge
 G-4 Penis enlarged in breadth and develop glands; scrotal skin become dark
 G-5 Mature adult sized penis, testes* and penis

Breast development stages in girls

- B-1 Preadolescent, elevated papilla
 B-2 Breast bud forms, elevated breast and papilla, increased areolar diameter
 B-3 Further enlargement of breast and areola without separation of the contours
 B-4 Well-defined breast contour with areola and papilla forming a secondary mound above the areola
 B-5 Mature breast with areola receding into general contour of breast and papilla projecting as nipple.

* The objective tool for measuring size of testis (over and above the conventional clinical palpation) is Prader's orchidometer

Table 7.3: Three phases of puberty growth spurt

- Phase 1 Moderate gain in height velocity in the prepubescent phase
 Phase 2 Both height and weight show rapid gain in the pubescent phase
 Phase 3 Growth velocity shows deceleration though weight gain continues in the postpubescent phase

Anxiety related to wet dreams causing night discharge in boys and delayed menses or vaginal discharge in girls may cause nonspecific neurotic manifestations such as intractable headache, abdominal pain, sleeplessness and lack of concentration.

Body image concerns (height, weight, muscles, complexion, facial features, hair, acne, breast size) may cause such problems as bulimia, anorexia nervosa, inferiority complex, depression, withdrawal, jealousy, undue argumentation and deterioration in day-to-day

functioning and studies. The relationship with family members and peers may suffer. Most body image concerns are invariably an outcome of distorted perceptions rather than reality.

More details follow under the heading "Adolescent Psychology" in this very Chapter.

FACTORS INFLUENCING ADOLESCENT HEALTH AND DEVELOPMENT

A. Modifiable (External) Factors

Protective Factors

- Positive family environment: Caring and meaningful relationship and family and neighborhood
- Positive school environment
- Encouragement for self-expression
- Opportunities for participation and contribution
- Structure and boundaries for behaviors
- Spiritual beliefs

These protective factors:

- Encourage and sustain positive behavior
- Reduce risk of negative health behavior and outcomes
- Support recovery from negative health outcomes

Social, Cultural and Political Factors

- Social norms and attitudes
- Relationship with family, friends and teachers?
- Interaction with peer groups
- Mass media
- Government policies

Gender-related Factors

- Greater attention, better nutrition, preferential treatment, more opportunities and resources for boys at the expense of girls
- Insufficient attention to boys as regards reproductive health and contraceptive use
- Encouragement to boys for risk behavior, resulting in injury and violence

B. Nonmodifiable (Internal) Factors

Age and sex are among the factors that cannot be modified.

ADOLESCENT PSYCHOLOGY

Self Esteem (*Self Concept*)

The adolescent's personal evaluation or view of "self" influences his feelings and behavior. It is the result of an interaction between the adolescent's temperament and the environmental influences and considerably contributes to motivation and performance, peer relationship, failure or success and ability to bounce back from a failure. Any sort of a conflict in (development of an adequate self-esteem may cause one or more psychological problems.

Formation of the Identity

Physical maturation, joining the peer group and heterosexual relationship are the hallmark of early adolescence. The middle and late adolescence is characterized by autonomy from parents, sex-role identity, morality and career choice. Failure to accomplish these tasks may cause psychological problems.

A vital feature of middle adolescence is tendency to join a peer group and endeavor to win popularity among friends circle. At the same time, the adolescent moves away from parents, challenges their authority and, as a result, frequently gets into a conflict with them. In case parents are understanding and accomodating, the adolescent usually tides over this phase and adopts to the situation.

The conflicts and pressures may contribute to such problems as depression, suicide or suicidal attempt, school problems (school phobia, failures) and juvenile delinquency.

Psychological Problems

Adolescent psychological problems may fall in one of the following three categories:

- *Emotional* which include anxiety, hypersensitivity, impulsiveness, moodiness, immaturity, withdrawal, etc.
- *Multivational* which include lack of ambition, low aspirational level, feelings of frustration, negative attitudes, lack of interests, etc.
- *Moral* which include feelings of guilt, sense of being lost, confused ideas of right and wrong, delinquencies such as lying, stealing, unruly behavior, etc.

ADOLESCENT SEXUALITY

Though an adolescent is still a child, he is almost an adult as far as physiological and sexual maturation is concerned as a result of hormonal changes. No doubt, this sudden transformation together with exposure to influences of peers and print and electronic media leaves him utterly confused on his knowledge, attitudes and behavior concerning sex.

Sexual Concerns

The adolescent is often anxious about nocturnal discharge, penile size, shape and erection, growth of hair, mensens, breasts, and appearance to influence the opposite sex. The usual barrier of communication with the parents enhances adolescent's worry.

Self-gratification

Most adolescents indulge in self-gratification (masturbation) to quench their sexual desire and obtain pleasure out of this practice. Yet, they are left with an intense feeling of "guilt" and run about foolishly to get treatment for this harmless practice from quacks and other unscrupulous elements.

Homosexuality

Sooner or later, the adolescent may develop a very intimate closeness with an individual of the same sex. As a rule this is a transitional phase in an adolescent's life and in due course dies down. However, in a small proportion of the adolescents, such an homosexual relationship may pass on into adult life on account of an enhanced "fixed identity", leading to problems.

Promiscuous Sex

Aping the West is usual in the developing countries such as India. Understandably, therefore, the promiscuity in adolescents is on an increase. This is not restricted to peer groups. Quite a proportion of adolescents mate with prostitutes. A large majority of these sexually active but ignorant adolescents never use any contraceptive measure such as condoms, thereby exposing themselves to unsafe (unprotected) sex, resulting in sexually transmitted disease (STD) and unwanted pregnancies, illegal abortions with complications, maternal deaths, abandoned babies and, no doubt, population explosion.

In order that adolescents do not grow up with beliefs and notions that are dangerous for the future sex life and protect themselves from sexual abuse and exploitation, it is being increasingly realized that sex education, in a well-conceptualized way, should be given in schools by the specially trained teachers. If need be, help from doctors, psychologists/psychiatrists and sexologists may also be sought for this purpose. We must empower children with knowledge and information so that they may fight the cancer of untruths with confidence. The argument by the cynics that burdening children's minds with what is essentially the task of the adults seems by and large unfounded.

ADOLESCENT NUTRITION

On account of a rapid gain in height and weight, nutritional requirements, including calories, proteins and micronutrients such as iron, calcium, zinc, folic acid and iodine, are at peak during adolescence (Table 7.4). The adolescents who participate in athletics and sports are in need of a higher intake of proteins as well as calories. Similarly, nutritional requirements of a pregnant adolescent are relatively much higher (Table 7.5). Risk for undernutrition and micronutrient deficiency are, therefore, increased during this period. In adolescent girls in particular, importance of nutrition is remarkable since the growth and development of infants is dictated by their mother's past nutritional status.

The adolescent is particularly vulnerable to certain peculiar eating disorders on account of hormonal and

psychological changes, say anorexia nervosa, bulimia, and obesity which are discussed later in this very chapter. In addition, fast food, junk food and snacking, which is fast becoming the order of the day, especially in urban adolescents but is imbalanced, may contribute to overweight and obesity plus nutritional deficiency states. The economically deprived children suffer from nutritional deprivation which they carry over to adolescence with physical and, at times, intellectual deficit limiting their productivity. The stunted and malnourished adolescent girls are particularly at a high risk of producing LEW babies when they become mothers.

SPECIAL HEALTH, MEDICAL AND PSYCHOSOCIAL PROBLEMS

Anorexia Nervosa and Bulimia

In a pursuit for "slimness" and "weight loss", many adolescents (by and large, girls), impose foolish dietetic restrictions on themselves (anorexia nervosa of "restrictor" type) or eat in binges and then get rid of the food intake by self-inducing vomiting or using cathartics (bulimia). As a result, they become grossly malnourished with disturbances related to almost all organ systems, i.e. electrolyte disturbances, postural hypotension, cardiac arrhythmias, CCF, hypothermia, amenorrhea, constipation, dry skin with lanugo hair, peripheral edema, rise in BUN, bone marrow hypoplasia, etc. Interestingly, the subjects are notably resistant to infection.

The exact etiology is unclear though it is generally believed to be a psychiatric eating disorder. The

Table 7.4: Nutritional requirements of Indian adolescents as per recommendations of the Indian Council of Medical Research (ICMR)

Age groups (years)	Weight (kg)	Calories kcal	Protein gram	Calcium mg	Phosphorous mg	Iron mg	Zinc mg	Iodine µg	Folic acid µg	Vit. A µg RE
10-12										
Boys	35.54	2194	51.9	600	600	34.2	15	150	100	600
Girls	37.91	1965	55	600	600	18.9	15	150	100	600
13-15										
Boys	47.88	2447	67	600	600	41.4	15	150	100	600
Girls	46.66	2056	62.1	600	600	28	15	150	100	600
16-18										
Boys	57.28	2642	75.1	500	500	49.5	15	150	100	600
Girls	49.92	2064	60.4	500	500	29.9	15	150	100	600

* Based on Indian diet of cereal and pulses

** Iron requirements are based on mixed cereal diet with dietary iron absorption of 3% in adolescent boys and 5% in adolescent girls

Table 7.5: Recommended dietary allowances for pregnant adolescents

	Food and Nutrition Board ICMR* USA		
	11-14 years	15-18 years	
Energy (kcal/day)	extra 500	extra 400	+ 300
Protein (g)	1.7g/kg	1.5g/kg	+ 15g/day
Vitamin A (µg RE)	800	800	—
Vitamin D (µg)	15	15	—
Vitamin C (mg)		60	70
Thiamine(mg)	1.5	1.5	+ 0.2
Riboflavin (mg)	1.6	1.6	+ 0.2
Niacin (mgNE)	17	17	+ 2
VitB ₆ (mg)	2.0	2.1	+ 0.5
Folate(ng)	370	400	+ 300
VitB ₁₂ (µg)	2.2	2.2	
Calcium (mg)	1600	1600	+ 600
Iron (mg)	30	30	+ 8
Zinc (mg)	15	15	
Iodine (µg)	175	175	

*Requirements in addition to those of age matched non-pregnant women

patients have such characteristics as developmental immaturity, isolation and excessive dependence. The family background is overprotective.

Management revolves around psychotherapy (including pharmacotherapy with antidepressant agents), behavior modification and nutritional rehabilitation.

Malnutrition

Nutritional needs during adolescence are considerably enhanced as a result of hike in growth during these years. Unless and until they are provided extra calories, proteins, vitamins and minerals in diet to meet the increased demands for rapid gain in weight and height, they run the risk of developing nutritional deficiency states.

Iron Deficiency Anemia (IDA)

Adolescents are likely to develop iron-deficiency anemia because of increased demands. In girls, an important additional factor is excessive loss of blood in menses. It is, therefore, advisable to provide them supplements of medicinal iron/folate, preferably with vitamin C. A public health approach comprising once weekly distribution of iron-folic acid supplementation (preferably with vitamin C) through schools and welfare centers is a desirable strategy.

Obesity

An adolescent is particularly prone to develop obesity. A multiplicity of factors, including growth spurt, hormonal changes, erroneous eating habits (say excessive consumption of icecream, candies, chocolates, sweets), excessive television viewing, lack of outdoor activity, etc. join hand to contribute to it. Obesity leads to psychological problems such as low self-esteem which further force them to turn to more food and isolation, causing further obesity.

The cornerstone of management is reduction in intake of calories and hike in physical activity. The pharmacotherapy aimed at suppressing appetite should be avoided.

Puberty Goiter

Puberty goiter is a common problem of the adolescents, especially the girls. Usually, it subsides in due course of time. But, at times, it may become much larger in size and multinodular. It should be treated with thyroid hormone.

Depression

Adolescence is a period of mood swings varying from depths of depression to heights of elation. This should be considered "normal".

In addition, "acute depressive reactions" are a sort of healthy grief response following death or separation from a loved one. These resolve in due course of time, occasionally after weeks or months.

"Neurotic depressive disorders" are unresolved grief reaction and are characterized by a feeling of guilt in relationship to the dead. A psychiatric treatment is in order.

"Masked depression" is characterized by denial and somatization of feelings of despair, hopelessness and helplessness by the adolescent. Manifestations include "acting-out" behavior in the form of substance abuse, school truancy, running away from home, multiple accidents, unexplained headache, abdominal pain, etc. A psychiatric treatment is mandatory.

"Psychotic depressive disorders" may have such additional manifestations as delusions of guilt, impaired reality testing and thought distortion. Psychiatric treatment is strongly indicated.

1 Suicide

Suicide is one of the important causes of deaths among adolescents. Its causes include serious conflicts and pressures, successive failures in examination, marriage against will, chronic illnesses causing fear of fatality, impotence, diminished competence, poor self-image, vulnerability to loss of a loved one and easy and increased access to medication that could facilitate suicide.

Most successful suicides are known to have occurred in individuals who have threatened ending life or who have made earlier attempts or gestures. Secondly, threats of suicide must never be taken casually, especially if the person leaves a suicide note, a sign of seriousness and premeditation. A family history of suicide is significant.

Among the methods of suicide figure ingestion of medication such as phenobarbital or tricyclic antidepressants in very large amount, hanging, setting fire to one's personnel, drowning, shooting or slashing one's neck or wrist.

Any suicidal attempt is an indication for a psychiatric evaluation and management. A short-term hospitalization is of distinct value in providing a secure environment to the subject and helps the individual in the constructive resolution of his conflict.

Substance Abuse

The menace of substance abuse has not spared the adolescents in the developing countries too. Such is the magnitude of the problem that it has been suggested that each and every adolescent should be assessed for the drug abuse and its physical and functional adverse effects.

Among the drugs abused by adolescents figure CNS stimulants (dextedrine, methedrine), CNS depressants (opiates), hallucinogens (LSD, phenylcyclidine, mushrooms, datura), volatile substances (gasoline sniffing, airplane glue, nitrites), marijuana (hashish), cocaine, alcohol, smoking, anabolic steroids, etc.

Among the factors contributing to drug abuse figure burning the midnight oil at time of examination, sleeplessness, enhancing concentration, to get out of a difficult and tense situation, "just for hecks" enhancing competence in athletics, etc.

The most important preventive measure is channelization of the energy of the adolescents and

creating awareness in them about the adverse effects of substance abuse. At times, services of an de-addiction center may be needed. Also see Chapter 23.

Juvenile Delinquency

A proportion of adolescents repeatedly indulge in antisocial behavior in the form of pre-mediated planned and purposeful unlawful activities. Such adolescents usually come from emotionally disturbed or broken families residing in overcrowded unhealthy environments with poor amenities. Often, a basically timid adolescent may act out to demonstrate his adventurous spirit in the eyes of his peers and indulge in a delinquent act (gang psychology).

Prevention lies in improving the environmental and family settings. The pediatrician can play a pivotal role by interacting with parents, community leaders, social workers, school teachers and psychologist/psychiatrists and thereby provide a team approach to have the delinquent adolescents adjusted in the society. Also see Chapter 6.

Adolescent Violence

The adolescent is especially prone to be assaulted physically or sexually. He is also vulnerable to develop behavioral problems, resulting in rejection by the parents, peer groups and school teachers. Some of them may indulge in violent crimes, including murders.

Teenage Pregnancy

In India and most other developing countries, high incidence of teenage pregnancy is because of early marriage (on an average 16 years). Of course, with increasing permissiveness and, consequent upon that, higher incidence of premarital sexual encounters, increasing number of pregnancies in unwed adolescent girls are occurring. These pregnant adolescents are decidedly at increased risk for obstetric and perinatal complications such as toxemia, postpartum hemorrhage (PPH), postpartum infection, stillborn infants and low birthweight infants. Later, they have difficulty in proper care of the child and have a tendency to have multiple pregnancies and children. Those of the pregnant unwed girls who opt for abortion (usually at the hands of the unscrupulous quacks) too are at a special risk.

The pediatrician should put efforts for primary prevention of adolescent pregnancy. A sexually-active adolescent needs appropriate contraceptive advice. Introduction of sex education in schools may well help in safeguarding against early marriage, premarital sex and adolescent pregnancy.

Sexually Transmitted Diseases (STD) and HIV/AIDS

Adolescents are on record as having an incredibly high incidence of STD (gonorrhea, syphilis, *Chlamydia*, chancroid, herpes progeneralis, *Trichomonas*) and HIV/AIDS because of sexual experimentation (usually unprotected/unsafe sex), biological characteristics of the vaginal epithelium, and intravenous drug abuse.

Manifestations may be in the form of pathological vaginal discharge (leukorrhea) because of development of vulvovaginitis or cervicitis. Such symptoms as lower abdominal pain, vaginal discharge, pyrexia and irregular vaginal bleed point to the so-called pelvic inflammatory disease (PID).

STD and allied infections are a potential risk to the sexual partner as well and may later be responsible for such serious sequelae as infertility and ectopic pregnancy.

The pediatricians must take the responsibility for creating awareness among adolescents about the transmission and prevention of these infections. They should also have the high-risk adolescents identified through screening to enable them to have timely treatment.

Menstrual Problems

Amenorrhea Absence of menstruation may be primary or secondary. In *primary amenorrhea*, menarche has never occurred. In *secondary amenorrhea*, there is cessation of menses for more than 3 months after establishment of a regular cycling. Table 7.6 lists the causes of amenorrhea in adolescent girls.

Determination of etiology of amenorrhea in the adolescent girl should permit initiation of appropriate treatment in a good proportion of the cases.

Menometrorrhagia Excessive menstrual bleeding may be the result of dysfunctional uterine bleeding, congenital coagulopathies (von Willebrand disease), aspirin ingestion, thrombocytopenia, exogenous hormones (oral contraceptives), thyroid disorders,

Table 7.6: Important causes of amenorrhea in adolescent girls

<i>Primary amenorrhea</i>	<i>Secondary amenorrhea</i>
Chromosomal abnormalities	Chronic illnesses
Gonadal dysgenesis	Malnutrition
Triple X syndrome	Diabetes mellitus
Isochromosomal abnormalities	Inflammatory bowel disease
Testicular feminization syndrome	Anorexia nervosa
Structural abnormalities	Cystic fibrosis
Imperforate hymen	Cyanotic congenital heart disease
Hematocolpos	
Hematometrium	
Agensis of cervix or uterus	

diabetes mellitus, estrogen-secreting ovarian tumors, trauma, infection, pregnancy, or abortion. A gynecological consultation is in order.

Dysmenorrhea Painful menstrual cramps are a leading cause of short-term school absenteeism in adolescent girls. The dominant type is primary. Secondary dysmenorrhea is the result of a structural abnormality of the uterus or cervix, a foreign body, endometritis or endometriosis. In primary dysmenorrhea, use of a prostaglandin-synthetase inhibitor is of value.

Premenstrual syndrome (PMS) It is characterized by such manifestations as breast engorgement and tenderness, fatigue, bloating, headache, increased appetite with craving for sweets and salty foodstuffs, weight gain, constipation, peripheral edema, irritability, mood swings, mental tension, and lack of concentration occurring 7 to 10 days before onset of periods and disappearing a day or two after the beginning of periods. The lifeline of management is reassurance.

Breast Disorders

Breast asymmetry True asymmetry usually follows surgery, injury or infection. Pseudoasymmetry is, as a rule, associated with deformity of spine (scoliosis) or thoracic cage.

Breast hypoplasia Its causes include quite frail but tall girls, hypothyroidism, ovarian dysfunction (Turner syndrome), adrenal hyperplasia, and androgen-producing tumors. A surgical correction (mammoplasty) is possible.

Congenital anomalies These include supernumerary nipples (polythelia), absence of nipples (athelia), absence of breast (amastia) and inverted nipples.

Breast mass A breast mass in an adolescent is usually a cyst, a fibroadenoma or an abscess. Whereas cystosarcoma (a low-grade malignancy) is infrequent, carcinoma of breast is extremely rare during adolescence. In case of a mass that shows persistence or increase in size, an aspiration or excision biopsy is indicated.

Gynecomastia Occurring in one-third of adolescent boys in early puberty, palpable development of breasts due to hormonal imbalance may be a matter of considerable concern. It is transient and resolves within 2 years. Rarely, it may be large and persistent, warranting plastic surgery.

Nipple discharge In addition to pregnancy, galactorrhea in adolescents may occur as a result of local stimulation, drugs (oral contraceptives, antihypertensives, tranquilizers, heroin, codeine, marijuana, amphetamines), pituitary or breast tumor or infection. Organic nipple discharge is termed *amenorrhea-galactorrhea syndrome* in which serum prolactin level is raised. Breast cancer is indeed rare in adolescence. Persistence of a mass or its enlargement is an indication for aspiration and/or excisional biopsy.

Penile Problems

Congenital anomalies These include hypospadias, epispadias, abnormal curvature, hypoplasia and erectile or ejaculatory dysfunction. If not attended to, the adolescent may suffer psychologically.

Skin lesions These include venereal warts (condylomata acuminata) which may even involve the urethra causing bleeding during voiding, genital herpes simplex causing edematous wheal and severe pruritus, syphilitic chancre over glans and prepuce, and chancroid with ulcer edges that are not indurated.

Balanitis and balanoposthitis Sepsis of the glans (*balanitis*) or foreskin (*balanoposthitis*) is a common problem and is nearly always associated with phimosis. In addition to local and oral antibiotic therapy, it is often advisable to carry circumcision for the severe phimosis.

Scrotal Problems

Undescended testes Cryptorchidism may be true or just a reflection of retractile testes, ectopic testes or absent

testes. Delay in treating the condition may be complicated by testicular malignancy or infertility.

Hydrocele When present, it is invariably of communicating type with the hernial sac.

Urologic Problems

A majority of the urologic problems, including enuresis, in adolescents pertain to voiding dysfunction and are often psychosomatic in origin. Nevertheless, such organic conditions as urethral valves or strictures, spina bifida occulta, and infection should be considered in the differential diagnosis.

In case of urethritis (usually a manifestation of STD), leading symptom is dysuria with or without discharge that may be clear or purulent.

Dermatological Problems

Acne It is the most common manifestation of increased level of androgens by increased size and secretions of sebaceous follicles and apocrine glands during adolescence. Over 80% teenagers suffer from it. It may be mild that clears in due course to severe that causes disfigurement of the face. Since appearance is a matter of considerable concern to the adolescent, he needs to be offered proper guidance and, if the need be, treatment. He must wash face frequently, avoid cosmetics and squeezing the lesions. In case of girls, it must be ensured that pregnancy is not there before resorting to medication with tetracyclines and/or cisretinoic acid (Isotretinoin). Also see Chapter 27.

Hirsutism As a result of excess of androgens, an adolescent girl may develop an excessive male type growth of hair. Though the commonest type is idiopathic, gonadal, adrenal, exogenous (drugs like androgenic steroids, minoxidil, diphenylhydantoin, cyclosporin, anabolic steroids, penicillamine, oral contraceptives, acetazolamide, diazoxide, danazol) and congenital anomalies (trisomy 18, de Lange syndrome) must be considered in differential diagnosis. Cosmetic correction is advisable. Simultaneously, attention should be directed to counter excessive androgens.

An adolescent's skin is vulnerable to other adverse influences like STD, HIV/AIDS, neurosis/psychosis (*trichotillomania*), contact sports (herpes simplex) and substance abuse.

Sleep Disorders

Narcolepsy It manifests as shortened rapid eye movement during wakefulness (REM sleep) with

excessive daytime sleepiness, hallucinations, sudden flaccidity or even paralysis of a muscle group during sleep (*cataplexy*), and enhanced daytime sleepiness after disturbed nighttime sleep because of apneic spells from airway obstruction (*apnea-hypersomnia syndrome*).

Insomnia Adolescents are particularly prone to delayed bedtime (*delayed sleep phase syndrome*). This as also depression may contribute to insomnia in around 15 percent of the adolescents.

Orthopedic Problems

Such problems as slipped capital femoral epiphysis, idiopathic scoliosis, Osgood-Schlatter disease, costochondritis of the sternoclavicular joint (*Tietze syndrome*) on account of rapid growth of long bones, open epiphyses, increased traction at insertion of muscles and pulls and pressures of sports are common during adolescence. Further, incidence of arthralgia from rubella, infectious mononucleosis and other viral infections is relatively high in adolescents.

Though infections of bones and joints are relatively less frequent in adolescents, these may follow as a complication of sickle-cell anemia or disseminated gonococemia.

About 10-14% adolescent girls and 5% boys manifest a slight curvature of the spine (scoliosis) during the peak of the height velocity curve. This requires no orthopedic attention unless the curve exceeds 10 degrees.

PROMOTION OF ADOLESCENT HEALTH

Health Education

Health providers role doesn't end up with just health education. They must coordinate with other agencies to educate the adolescents on several related matters such as nutrition, sexuality and substance abuse etc. All efforts must be made to reach out to the adolescents, both school-goers and nonschool-goers. For this objective, "adolescent-friendly health services" (AFHS) are needed. Use of mass media and school curriculum may also be made. Special stress should be on matters related to:

- Development of secondary sex characters
- Menarche, menstrual hygiene and associated problems in girls
- Seminal discharge in boys
- Body image

- Nutritional needs, including iron
- Managing emotions and stress
- Reproductive process, conception, childbirth
- Safe sex and Contraception
- Right age for marriage
- HIV/AIDS, hepatitis B and other STDs
- Substance abuse, alcohol and tobacco

Improved knowledge about health matters and negative consequences of risk-taking behavior should be considered as an important step though not a fool-proof, strategy for safe behavior among adolescents.

Life Skills Education (LSE)/ Skills-based Education (SBE)

Life skills are "abilities" for adaptive and positive behavior so that the individual can deal effectively with demands and challenges of day-to-day life.

Skills-based education (SBE), given during face-to-face counseling, proves more effective in convincing the adolescent not to indulge in risk-taking activity such as violence, molestation and unprotected sex.

Family Life Education (FLE)

This WHO strategy is based on the observation that when adolescents are assisted to develop responsible attitudes towards relationship in the family settings, their emotional, psychological, social and sexual needs get satisfied. Its crux is "awareness through education". Its various components include adolescent nutrition, personality development, understanding human sexuality and preparation for future parenthood.

Counseling for Managing Stress and Emotions

Stress is inability to cope with the demands. It causes "general adaptation syndrome". It involves both nervous system (predominantly "autonomic") which reacts immediately and endocrine (hormone) system which takes time to react but the reaction persists much longer. In fact, it affects almost all systems, including immune system, to certain extent.

Three types of stress are: physical (overcrowding in class, bus; noise and environmental pollution), psychological (intense academic demands) and psychosocial (conflicts with peers, teachers, family members).

The result of all these types is either eustress or distress. *Eustress* promotes productivity and facilitates efforts. *Distress* causes loss of productivity and health problems.

Adolescents need to be taught the art of stress management.

Nutritional Care and Counseling

A multisectoral approach should ensure sufficient food supply and its equitable distribution, and improved knowledge and information about nutrition, with special reference to healthy eating and healthy lifestyle and increased needs during adolescence without any discrimination to the girl child. Nutritional promotion should operate at school, family (household) and community levels.

Early Diagnosis and Management of Medical and Behavioral Conditions

It is important to detect medical problems and behavioral problems (particularly unhealthy eating habits, substance abuse, sex-related problems, and violence and aggression) early enough. Appropriate management in conducive environment and with assistance from pediatrician and, if the need be, from a psychologist/psychiatrist should in no case be delayed.

Legislation

Experience in Europe has demonstrated that legislation and regulatory policies discourage risk-

taking behavior amongst adolescents. Nevertheless, there may be difficulties in implementation of laws in a country like India. Restriction on smoking in public places, legislation against child labor and legal age of marriage continue to be flouted mercilessly.

FURTHER READING

Articles/Chapters

1. Aneja S. Nutritional concerns in adolescence. In Oupte S (Ed) *Recent Advances in Pediatrics* (Special Vol. 6: Gastroenterology, Hepatology & Nutrition). New Delhi: Jaypee 2000:519.
2. Bhav S, Paul MK. Counseling for adolescents. In Bhav S, Nair MKC (Eds): *IAP Manual of Adolescent Care*. Mumbai: Indian Academy of Pediatrics 2000:46.
3. Indian Council of Medical Research: *Nutritional Requirements and Recommended Dietary Allowances for Indians. Report of an Expert Committee*, New Delhi: ICMR 1992.
4. Jenkins RR. Delivery of health care to adolescence. In Kliegman RM, Behrman RE, Jenson HB, Stanton (Eds): *Nelson Textbook of Pediatrics*, 18th edn. Philadelphia: Saunders 2008:643-646.
5. Singh T. Adolescence and youth: a psychological viewpoint. In Gupte S (Ed): *Recent Advances in Pediatrics*, Vol 10. New Delhi: Jaypee 2000:289.

Books/Monographs

1. Bhav SY, Greydanus DE, Nair MKC, Parthasarthy A, Menon PSN (Eds): *Bhav's Textbook of Adolescent Medicine*. New Delhi: Jaypee 2006.
2. Gupte S, Bhav S: *Recent Advances in Pediatrics (Special Vol 16: Adolescence)*. New Delhi: Jaypee 2006.

CHAPTER



Pediatric Biostatistics and Informatics

Mridula Chatterjee, Suraj Gupte

BIOSTATISTICS

Biostatistics is the science of management of uncertainties in health and disease. It deals with the quantitative rather than the qualitative aspect of health and disease. The cornerstone of all biostatistical endeavours is the *measurements* through which all quantities are obtained and, thereafter, uncertainties and variations studied. This involves systematic collection, organization, analysis and interpretation of numerical data pertaining to health and disease. The measurements are employed:

- to assess the levels of health
- to assess the severity and level of disease
- to establish and interpret the reference values of various parameters
- to evaluate probabilities in diagnosis and management
- to assess the validity of medical tools.

The Apgar score, heart and respiratory rates and weight and height for age are the commonly used quantitative measurements for assessment of health and departure from it in case of infants and children. An example of assessing the severity of disease is the Glasgow scoring system that is employed to determine the level of unconsciousness.

The term, *medical statistics*, refers to statistics pertaining to medical sciences, data related to human diseases in particular. The term, *morbidity statistics*, refers to statistics pertaining to sickness. The statistics dealing with births, deaths and marriages fall under the category, *vital statistics*.

A reasonable knowledge of the basics of biostatistics is essential for understanding data on health information, which is an integral part of the health system, particularly its pediatric component.

The Concept of Normal

The term “normal” denotes two potential meanings:

1. a person or process is healthy, and
2. measured value falls within the normal range.

When we talk of normality in relation to growth and development, we indeed refer to quantitative normality. In terms of height, which is normally distributed within a population, a graph with the height on the X axis and the number of children of that height on the Y axis, a bell-shaped curve is formed. This curve indicates a normal or Gaussian distribution. The peak of the curve corresponds to the arithmetical mean of the sample which, in turn, equals the median and the mode (definitions *vide infra*). *Skewed* is the term applied to a distribution in which the mean, median and mode are unequal. The limit within which there is clustering of the values in the vicinity of the mean determines the bell in the Gaussian distribution and is expressed mathematically by the term, *standard deviation (SD)*, which is tied to the concept of normal distribution.

Data, Information and Intelligence

The term *data* refers to discrete observations of attributes or events that need to be considered as a group collected from an institution or a system. Without various conversions, data are not of much statistical value.

The term *information* refers to the transformation of data by their reduction, summarization and adjustment for variations like the age composition of the population to enable comparisons over time and place are workable.

The term *intelligence* refers to the transformation of information through integration and processing

1 with experience and perceptions based on social and political values.

Remember that data that are not transformed into information and information that is not transformed into intelligence are of limited value only. These fail to guide the decision-makers, policy-makers, planners, administrators and health care personnel.

Types of Studies

There are two major types of studies: cross-sectional study and longitudinal study. A *cross-sectional study* refers to the study of a sample of individuals examined at one time only. On the contrary, a *longitudinal study* refers to the study of a sample of individuals periodically at specific times. The latter is, therefore, likely to take quite long time but, nevertheless, is of greater relevance compared to the former.

Statistical Averages

The term *average* implies a particular central value in the distribution around which the remaining values are distributed.

Arithmetic Mean

This is the most useful statistical averages. It is calculated by adding the individual observations (summation) and then dividing it by the number of observations. It is denoted by the sign "X bar". If a measurement (X) of 10 adolescents is 20.5 cm, 21 cm, 20.2 cm, 19.8 cm, 21.5 cm, 20.3 cm, 19.7 cm, 20.5 cm, 21.1 cm, and 20.7 cm, the total becomes 205.3 cm. The mean is 205.3 cm divided by 10 which is 20.53 cm.

The Median

This is an average that does not depend upon the total and the number of items. The data is first arranged in an ascending or descending order of magnitude. Then, the value of the middle observation is the median. If the number of values is even, then the median is obtained by taking the average of the two middle values.

Median is more representative of the average than the mean.

The Mode

This is the most commonly occurring value in a distribution of data. In the above-mentioned example,

since 20.5 is the most frequently occurring observation, the mode of the distribution is 20.5 cm. It is not often employed in pediatric statistics.

Measures of Variation (Dispersion)

The Range

This is the simple measure of dispersion. It is the difference between the highest and the lowest values in a given sample. Since it denotes only the extremes of two values and nothing in between, it is not of much value.

The Mean Deviation

This is the average of the deviations from the arithmetic mean and is given by the following formula:

$$\text{Mean deviation (MD)} = \frac{\sum (X - \bar{X})}{n}$$

The Standard Deviation

This is calculated as the root of the mean of the sum of squared deviation. The two formulas for the purpose are:

1. Standard deviation (SD) = $\sqrt{\frac{\sum (X - \bar{X})^2}{n}}$
2. Standard deviation (SD) = $\sqrt{\frac{\sum (X - \bar{X})^2}{n-1}}$

where SD = standard deviation

S = sum of the squared deviation

First formula is basic and employed when sample size >30. Second (i.e. modified) formula is for sample size <30.

The following steps are involved in calculating the standard deviation:

- Take the deviation of each value from the arithmetic mean.
- Now, square each deviation.
- Add up the squared deviations.
- Divide the result by the number of observations
- Finally, take the square root. This gives the standard deviation.

The prefix (+) to SD value indicates a dispersion to the higher side whereas the prefix (-) denotes the same to lower side.

Table 8.1: Standard deviation: interpretation in terms of observations falling within the range

Standard deviation (SD)	Percentage
One (plus/minus)	68.3
Two (plus/minus)	95.4
Three (plus/minus)	99.7

Table 8.2: Standard deviation: probability of deviation from mean

Standard deviation (SD)	Percentage
One (plus/minus)	16.0
Two (plus/minus)	2.3
Three (plus/minus)	0.13

One SD signifies that about 68% observations are within this range. Two SD signifies about 95% and three SD as high as 99.7% of the values lying within the particular range (Tables 8.1 and 8.2). In practice, it is infrequent to have values above two SD in a normal population.

Percentile

The term *percentile* refers to the frequency distribution curves. To be precise, the percentile is the percentage of individuals in the group that have attained a certain measured quantity (say a weight of 17 kg or a height of 95 cm) or a developmental milestone. The percentile cutoffs may be calculated from the mean and SD. For example, the 5th percentile corresponds to -1.65 SD, 10th percentile to -1.3 SD and 25th percentile to -0.7 SD. Third percentile means that 97% cases are above and 2% below. Similarly, 20th percentile means that 80% cases are above and only 19% below. Generally, normal range of observations falls between 3rd and 97th percentile.

Significant Value

Probability

Consequent upon the appropriate analysis of data, a conclusion is required to be drawn whether the event being investigated had a certain probability of being secondary to a “chance”. The probability may well be very marginal in which case it is concluded that the event was not the result of a sheer chance.

Probability is referred to as the *p value*. When the value is equal to or less than 0.05, the study results are

Table 8.3: Interpretation of commonly employed expressions pertaining to probability (*p* value)

<i>p. value</i>	Significance (Interpretation)
< 0.001	Highly significant
< 0.01	Very significant
< 0.05	Significant
> 0.05	Insignificant

considered to be statistically significant. This means that there is only 1 in 20 chance or even less that the observed results occurred due to chance. The important expression with significance are listed in Table 8.3.

MEDICAL INFORMATICS, TELEMEDICINE, CYBERMEDICINE AND INTERNET

During the era of information science, medical informatics is emerging as a new speciality and perhaps, in next decade, this branch of science will be as fundamental to the practice of medicine as the study of anatomy and physiology.

Medical informatics is the name given to the study of clinical information and communication process. It is the rational study of the way we think about patient, the way the treatment is defined, selected and evolved, i.e. how medical knowledge is created, shaped and applied. This science also includes the study how we organize ourselves to create and run health care organization.

The simplified definition of medical informatics is the “computer applications in medical care”. The other complicated definition is it is an emerging discipline involving the study, invention, and implementation of structures and algorithms to improve communication, understanding and management of medical information. The end objective of medical informatics is the coalescing of data, knowledge and the tools necessary to apply that data and knowledge in the decision-making process, at the time and place that a decision needs to be made. The focus on the structures and algorithms necessary to manipulate the information separates medical informatics from other medical disciplines where information content is the focus.

Thus, we find that medical informatics is concerned with information processing and information management carried out in medical knowledge context and uses the following methods of information technology: acquisition, processing, control, interpretation, transformation, transfer and presentation of data.

The sciences contributing medical informatics include computer science, artificial intelligence, decision theory, statistics, cognitive science, information management, health policy and of course medical science.

Applications of Medical Informatics

- a. To design decision support system for therapeutic and preventive intervention.
- b. Coding, storage, retrieval and transmission of data for patient care.
- c. Development of computer tools for research.
- d. Transmission and teaching of medical knowledge.
- e. Knowledge discovery.

Telemedicine

It is the exchange of medical information at a distance, whether that information is voice, an image, elements of medical records, live video or command to a surgical robot (Coiera 2000).

It may also be defined as the use of telecommunication for medical diagnosis, patient care and involves use of information technology as a medium for medical service specially at sites that are distant from provider. This transfer of medical data may utilize a variety of telecommunication technology including but not limited to ordinary telephone lines. ISDN, ATM, the internet and satellite.

Telemedicine covers a growing number of medical specialties for example cardiology, radiology, dermatology, psychiatry, oncology, pathology, ophthalmology, hematology, ENT, nephrology, surgery, home care, general care, pre-hospital care.

There are two basic types of interaction in telemedicine. Store and forward also known as “pre-recorded” or “asynchronous” where the information being exchanged between two sites is recorded (stored) in some format. Common examples are the transmission of still images, heart sounds, speech and video. This is typically used for non-emergency situations, when a diagnosis or consultation may be made in the next 24-48 hours and sent back.

Real-time, also known as Videoconferencing or “synchronous” when information is provided in real-time with the patients being able to interact at once (Wootton 1999). In this situation store and forward would be inappropriate as the nature of service demands a rapid respond.

Uses of Telemedicine

1. Health care services in remote area by experts directly or by on line data base; It offers almost instant access to medical aids. The continuity of care could be maintained with telemedicine in remote areas.
2. Patient management in terms of investigation, diagnosis and treatment for example by telecardiology, telepathology, teleradiology, etc. The images and/or records could be transmitted for this purpose.
3. Medical education — teaching using real time patient for a medical education purpose and teleconference for continuing education.

Thus by telehealth technologies, successful relationship could be established between rural hospitals and higher equipped centers.

The specific applications of telemedicine include:

1. Electronic management and transport of patient informations and records for diagnostic purposes via teleconsultation and video conferencing.
2. Image compression for efficient storage and retrieval of image data. Example—in telepathology the digitalized picture taken with the help of telecamera can be transferred from one place to a pathologist at distance, where the static images of the slides can be stored in some format and the pathologist at distance can retrieve the image data when required.
3. The image processing for diagnostic purpose. Example—ECG monitoring by telecardiology technique. Here the community hospitals are linked by modem with telecardiology laboratory. This link allows the ECG strips to be transmitted electronically in their laboratory for interpretation. The other example, where the pathological images are transferred at distant telepathology lab and the pathologist would be able to control the microscope, alter the magnification, auto focus or steer the microscope table similar to conventional slide reading.
4. Electronic processing of health and medical claims.
5. Electronic inventory to support community health care organizations.
6. Teleconference for professional training, education and consultation.

7. Digital transmission of 2D or 3D medical images e.g. echo cardiographic images or MRI/CT images could be transmitted at distant telecardiology or teleradiology laboratory.
8. Computerized control of medical equipment's, e.g. control over surgical robot.

Distance Communication by Video Conferencing (Fig. 8.1)

It is one of the fastest growing areas of information technology and is the combination of dedicated audio, video and communication technology for real time interaction and often used by group of people who gather in a specific setting to communicate with other group at geographically dispersed locations. In nutshell, this technology allows people at two or more locations to see and hear each other at the same time.

Videoconferencing could be of three types:

- a. Point to point videoconferencing, i.e. there are two participating sites for exchange of data and share applications. This is also known as desktop videoconferencing.
- b. One to many videoconferencing, i.e. group videoconferencing where audio and video communications occurs between one main site to a number of other sites.
- c. The third, type of videoconferencing is multi point where full audio-video interaction occurs between three or more locations.

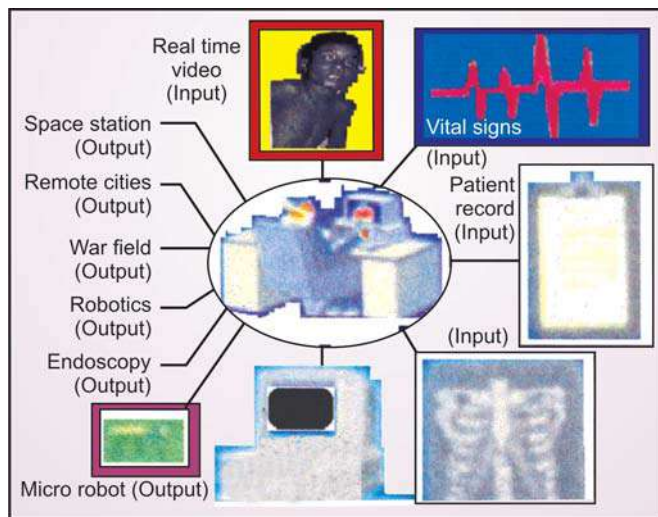

Fig. 8.1: Videoconferencing

The main components of telematics are:

- Remote database access/update:
- Tele-monitoring:
- Tele videoconferencing;
- Case handling/message passing.

Cybermedicine and Cyberhealth Services

Cybermedicine is defined as a new academic specialty at the cross-road of medical informatic and public health, studying applications of the internet and global networking technologies to medicine and public health, examining the impact and implications on the internet and evaluating opportunities and the challenges for health care or in short, Cybermedicine is the medicine in cyberspace where cyberspace denotes the internet.

Cybermedicine is distinctive from telemedicine with much overlapping as the internet can also be used as a medium for telemedical applications. While telemedicine focuses primarily on a restricted exchange of clinical confidential date with a limited number of participants, mainly between physician and physician, or patient and physician, Cybermedicine is a global exchange of open clinical or non-clinical information between any two persons not necessarily between patient and physician. Further telemedicine is applied for diagnostic and curative purpose while Cybermedicine is applied to preventive medicine or public health (Fig. 8.2).

Illustrations

1. A student in a chemistry department of a university in Japan was very ill. The medical experts of the city were unable to diagnose the rare disease. The friends of the student sought help via the internet.

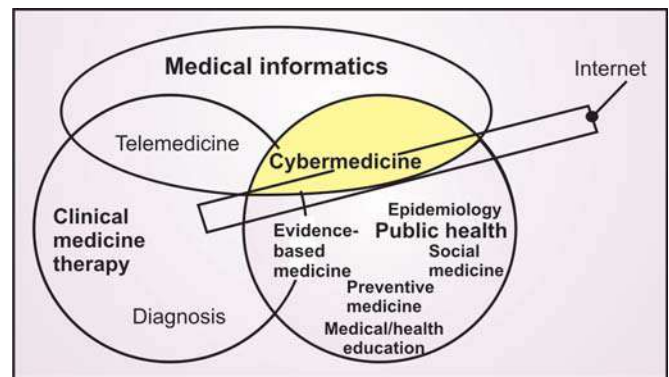

Fig. 8.2: Telemedicine vis-a-vis cybermedicine

They posted their friends symptoms on a electronic bulletin board. Within 3 hours they received e-mail reply from a doctor who could help. Later on, they received thousands of e-mail responses from world famous medical experts who opined the diagnosis as thallium poisoning. They offered prescriptions and treatments which saved the student's life.

2. A seven-year-male child comes at community hospital with epistaxis and purpuric rash. The treating physician draws a peripheral blood film, stains it and transmits the image through specialized microscope fitted with telecamera to a pathologist at a tertiary.' referral center. The physician also transmits other clinical informations about this patient to the pathologist and a pediatrician at another center. All these three doctors can communicate with each other face to face through videoconferencing and come to a final diagnosis and plan of treatment.
3. Two surgeons at two different sites say A and B, performs an intra-abdominal operation on a patient at site C. A surgical technician at site C pushes three probes into the abdomen of the patient. One of the probes has a tiny fiber optic array containing a set of 3D video lenses and light source. The other two are miniature servo operated mechanical arms with holding, cutting and suction devices. The surgeons at sites A and B have high definition video monitors, wearing 3D spectacles can manipulate these probes. The patient can be discharged within 24 hours. This is an example of robotic surgery. These are the few examples how the internet and telemedicine can help the mankind.

Limitations and Key Issues of Telehealth Medicine

- a. Issues of confidentiality—Medical confidentiality is believed to be one of the basic ethics for a physician since ancient time. But in the era of hightech information technology this environment of confidentiality is in question.
- b. Legal and ethical issues—Though yet to be tested in the court of law, the question about the ultimate clinical responsibility is not yet decided. The other hinders in the development of telemedicine are medical malpractice and breach of duty.
- c. Licensure of providers in other states—Traditionally, physicians and other health care practitioners are required to obtain licenses from every country in which they practice. The introduction of telemedicine has confused this requirement. It is unclear whether the patient 'travels' to the provider, meaning the provider need only be licensed in the country where he or she is physically located, or whether the provider 'travel' to the patient.
- d. Cost effectiveness.
- e. Quality issues—The quality of information is the critical factor for the use of cybermedicine for consumer empowerment patient support, health education and evidence based medicine. The studies showed that important aspects of quality such as reliability, accessibility and completeness of information and advice found on the internet are extremely variable, ranging from useful to dangerous.
- f. Lack of standard—This is another concern though internet protocols led to a global standardization of how computers talk to each other, standardization of many higher levels such as medical applications still has to be achieved to reach interoperability of medical internet resources.
- g. Social issues—The lack of local language content and low income and poor education is a big barrier in accessing health and medical content on line.
- h. Control on drug prescriptions will become loose.
- i. New syndromes like 'information overload confusion' and 'cyberhypochondriacs' may emerge.

The Internet

The network that connects other network of computers around the globe into a seamless network.

World Wide Web

The world wide web (www) is one of the most important innovation on the internet. It is a software layer that provides users with a simple way of accessing information. It is thus a massive collection of static and interactive documents that are linked together. The web allows users to create and exchange text, images and video documents.

Electronic Mail

Electronic mail or e-mail is typically used to send short textual messages between computer users and is one

of a number of electronic data exchange services available to those with access to a computer network.

Future Developments

Medical informatics has just started its contribution in the medical field. In near future it is expected that there will be a radical change in the quality of health care services. To day, there are technical limitations in using internet. It is expected that future generation internet will operate at a very high speed. Sight, sound and even touch will be integrated through powerful computers, displays and network. This has been referred as 'quantity leap'. The advanced development of robotics and sensors has brought greater sophistication to the technological range of equipment for hospitals.

"The intelligent bed is already with us and the robotic, sensor filled hospital is on the drawing board". Robotic beds are only one of a number of initiatives that provide a quantum leap in the re-definition of telemedicine. Engineers at the Pacific Northwest laboratory have developed Telesmell, a prototypical system that would use an electronic nose to capture the essence of odors, encode and transmit the data to the telemedicine site and then use a decoder to reconstruct the odor for the consulting expert to smell. Alternatively, a neural network might be introduced to analyze the odor for the operator, negating the need

to reconstruct it remotely. However, such systems are still in their infancy.

The next revolution is what is called 'quality leap' where the web will have 'machine understandable informations' with the help of 'intelligent software agents'. In short, the machine itself will act intelligently in delivering future health care services.

FURTHER READING

Articles/Chapters

1. Chakraborty M: Distant Communication Using Video-Conferencing. *CSI Communicat* 2003;36:1.
2. Coiera E: Recent advances: medical informatics. *Br Med J* 1995;310:381.
3. Indrayan A, Satyanarayana L. Essentials of biostatistics: reference values in medicine and validity of diagnostic tests. *Indian Pediatr* 2000;37:285.
4. Mitra A. Telemedicine and telecare. *CSI Communicat* 2001;24:4.
5. Park K. Health information and basic medical statistics. In *Park's Textbook of Preventive and Social Medicine*, 19th edn. Jabalpur: Banarsidas Bhanot 2007:692.
6. Passi GR. Cybermedicine: promises and perils. *Indian Pediatr* 2000;37:481.
7. Thacker N, Vidyashankar C. Telemedicine. In Thacker N, Shendurnikar N, Shah AP, Unni JC (Eds): *Computers for Doctors*. New Delhi: Jaypee 2003:127.

Books/Monographs

1. Coiera E: *Guide to Medical Informatics*. London: Chapman and Hall 2000.
2. Rudolph E. *Informatics*. London: Smith and Smith 2007.

CHAPTER



Community Pediatrics

Tejinder Singh, Suraj Gupte

HEALTH

Today, health is no longer conceived as “absence of disease”. The World Health Organization (WHO) definition of health, which is now universally adopted, is as follows:

“Health is a state of complete physical, mental and social wellbeing, and not merely an absence of disease or infirmity.”

An individual living in a state of physical, mental and social wellbeing is said to be enjoying *positive health* which is a basic human right and a worldwide social goal. The importance accorded by the WHO to health is reflected in its laudable resolve of “attainment by all citizens of the world by the year 2000 of a level of health that will permit them to lead a social and economically productive life.”

The concept of “Primary health care” dates back to *Alma Ata Declaration* of 1978. According to this WHO approach, based on principles of social equality, nation-wide coverage self-reliance, intersectoral coordination and people’s involvement, “rural population of developing countries must have a provision of at least the base minimum of health services.” The approach has been described as:

- “Health by the people”
- Placing people’s health in people’s hands.”

COMMUNITY PEDIATRICS

Community pediatrics is a concept rather than a branch of pediatrics, implying that “health is determined by interaction between the child, his environment and the society in which he lives”. It is, by no means, a measurable quantity, independent of this vital relationship.

To put it in other words: *Community pediatrics* means pediatrics as it applies to the child, his family and the community. The objective is to carry the health care to the doorstep of the “needy” through various categories of workers, including those trained at grassroot level. In the Third World countries, great majority of the vulnerable population lives in villages, periurban slums and labor colonies. The most practical approach is to carry out the health care within the home environment or in the neighborhood of the family. Yet, it is wrong to think that the term refers to the practice of pediatrics, only outside the hospitals, as though the latter are not part and parcel of the community. As a matter of fact the hospitals are as important a component of the community as health centers, schools, *creches*, homes for the handicapped or the daycare centers.

Basic Principles

The two essential areas of study in *community pediatrics* are:

1. The health of *child population* in relation to its social environment, i.e. the total community.
2. The health of the *individual child* as a result of multitude of social influences (both positive and negative).

Whereas the first constitutes a part of social medicine, the second is a part of clinical medicine. Both have got to operate together for the rational delivery of preventive and curative services to the vulnerable population.

No doubt, the principles of *community pediatrics* remain more or less the same in developing as also the developed countries. Their application, of course, varies from country to country. This is important, also

in view of the fact that each country may have its special problems needing priority attention. In the same country, there may also be regional variations—in fact variations from community to community.

Advantages

1. Health care goes to the susceptible population, thus ensuring protection to those who may not otherwise seek advice.
2. The concept ensures community participation at all stages.
3. A community based pediatric project can be started in a simple mud-walled/tiled structure. The equipment and manpower are locally available at relatively low cost.
4. It monitors the health and nutritional status of infants and children on a continuing basis. This considerably brings down morbidity and mortality.
5. It contributes enormously to *family welfare* by ensuring survival of the child and convincing the parents of the advisability, to “restrict the number of children to 1 or 2”.
6. It reduces undue burden on the hospitals which, in any case, are not the right place for tackling most of the problems encountered in the developing regions.

PREVENTIVE PEDIATRICS

By the term, *preventive pediatrics*, is meant “prevention of disease and promotion of physical, mental and social wellbeing of children with the aim of attaining a positive health.” Pediatrics, in actuality is largely preventive in its objective.

It is broadly divided into two: (i) antenatal preventive pediatrics, and (ii) postnatal preventive pediatrics.

Antenatal preventive pediatrics includes such measures as adequate nutrition of the pregnant mother, prevention of communicable diseases, preparation and education of the mother for delivery, mothercraft and breastfeeding, etc.

Postnatal preventive pediatrics includes such measures as periodic medical checkup of infants, supervision of nutrition, immunization, accident prevention, and psychologic supervision.

SOCIAL PEDIATRICS

By the term, *social pediatrics*, is meant “application of the principles of social medicine to pediatrics in order

to obtain a more complete understanding of the problems of children so as to prevent and treat disease and promote their adequate growth and development through an organized health structure.”

Social pediatrics is, therefore, understandably concerned with the delivery of comprehensive and continuing child health care services and to bring them within the reach of the total community.

In order to ensure adequate physical, mental and social growth of the child, we must meet his total health needs, namely:

- healthy and happy parents
- balanced and nutritious diet
- clean, healthful house and living environments
- such developmental needs as play, amusement; love, affection, security; recognition; recreation; company of other children
- educational provisions/opportunities.

The coordination between social pediatrics, social obstetrics and social medicine has made a sea change in providing comprehensive mother and child health (MCH) care services, including family welfare/planning. Nothing short of this strategy is likely to promote community health, especially in the developing world.

The term, *anticipatory pediatrics*, implies anticipation of certain happenings in the growth and development of the child, both normal and abnormal, including disease. As a result, the parents remain prepared for certain developments and the attending doctor can plan preventive measures for the untoward developments. In case of a disease, he can anticipate the complications/sequelae and take preventive action, or, if that is not workable, take early action for treatment.

The term, *total pediatric care*, denotes preventive, promotive, educative, curative and rehabilitative service to the child. In nutshell, it covers all facets of child care and welfare—the “total (whole) child”, so to say.

FAMILY HEALTH

Family health refers to the overall health of the individual family members. It takes into account the interrelationship and interdependence of the physical and mental health states of individual family members who live together. Thus, it determines and at the same time is determined by the effective functioning of the family as a biological and cultural unit with a cultural setting.

1 Factors Influencing Family Health

Environmental Housing and sanitary conditions, drinking water, environmental pollution.

Social Socioeconomic status, nutritional status, level of literacy, fertility rate, family size.

Family Health Program

In practice family health has come to mean the sum-total of MCH, nutrition, health education, immunization and family planning. The successful operation of the strategy can induce families to assume responsibility for their health and welfare. This is a contribution to the community either.

The essential criteria of a sound family health program are:

Firstly, it should be able to offer primary, preventive and promotive health care, as a continuous process rather than at intervals.

Secondly, the population should have these facilities at the doorstep.

Thirdly, it should be backed by a sound referral unit, available at a short distance.

UNDER-FIVES CLINICS

The modified *Well-Baby Clinic* of the West that blends preventive as well as curative activities for preschool children has been called the *Under-5s or Young Child Clinic* in the developing areas of the world. The concept of such clinics originates from the fact that an overworked rural mother cannot carry her healthy 6-month-old infant to one type of clinic for vaccination and a 3-year-old child—suffering from some ailment—to another center.

Why such an exclusively preferential stress on the under-5s? Firstly, they are a special-risk group needing particular health care. They constitute 17% of the country's total population but account for as high as 50% of the total deaths, the major causes of morbidity and mortality being malnutrition, infections and diarrheal disease. Secondly, common illnesses of this age group—say malnutrition, infections, diarrheal disease, accidents, etc.—are all preventable. Thirdly, this age period is known for its accelerated growth and development, warranting regular monitoring. Fourthly, this age group needs special inputs so that children are brought into the orbit of special health care.

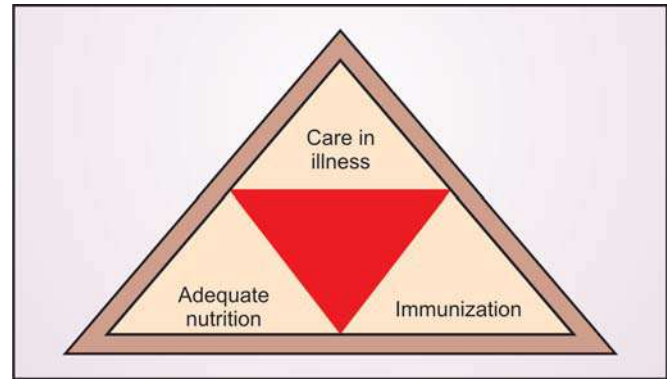

Fig. 9.1: Symbol for under-5s clinic. Central triangle (red) represents family planning. The line bordering the big triangle represents health teaching to the mother

The services rendered by the clinic are set out in the symbol for the Under-5s Clinics (Fig. 9.1). The apex of the large triangle represents *care in illness* by a trained health worker. The left triangle represents *adequate nutrition*. The health worker attempts to identify early onset of growth failure and malnutrition through the Road-to-Health Card, provides supplementary nutrition and gives necessary nutrition education to the mothers. The right triangle represents *immunization*, indicating coverage of at least the six diseases—tuberculosis, polio, diphtheria pertussis, tetanus and measles—and, if possible, typhoid as well under the Universal Immunization Program (UIP), formerly designated Expanded Program on Immunization. The central triangle *represents family planning*. The aim is to give to the mother all the advice about family planning. The border across the symbol represents *health teaching* to the mother through posters, charts, sketches, diagrams, etc.

The *Under-5s Clinic* is usually located in a village, a slum or a labor colony. It is managed by a health worker trained in child health and nutrition. She gives nutrition education to the mothers, weighs the children at least once a month and immunizes them against infectious diseases. She also makes home visits to educate the mothers and to make sure that they care to bring their children to the clinic for regular check-up.

At times, such clinics also provide low-cost weaning foods to fight impending malnutrition in the preschoolers.

BABY-FRIENDLY HOSPITAL INITIATIVE (BFHI)

The *Baby-Friendly Hospital Initiative* aims at making hospitals more supportive of a primary health care

approach. Such a focus on hospitals is the outcome of inappropriate health care practices that have developed in the past. There is evidence that practices (wrong or right) followed in hospitals have a multiplier effect that set examples for health practitioners in the community.

A baby friendly hospital is a hospital that follows the WHO/UNICEF Code of Practice which sets out the “Ten Steps to Successful Breastfeeding” (Table 9.1).

The “Baby-friendly hospital” campaign was launched by the WHO and UNICEF in mid-1991 in Ankara (Turkey), to boost breastfeeding and to counter the worldwide trend towards bottle-feeding. The philosophy behind this new strategy is that hospitals set the standards for primary care and act as the major providers and trend setters, thereby influencing the behavior of the health providers and the community. What is practised in hospitals is viewed by community at large as the right thing to do. Making hospitals baby friendly could, therefore, contribute considerably to curb the trend in favor of bottle feeding and promoting breastfeeding.

The movement that took off in 1991 in 12 countries has now become global. Experience has shown that the following benefits in such hospitals are immediate, obvious and substantial:

- Decrease in infection rate
- Improved survival of low birthweight infants

Table 9.1: WHO/UNICEF’s ten steps to successful breastfeeding

1. Have a written breastfeeding policy-routinely communicated to all health staff.
2. Train all health staff in skills to implement this policy.
3. Inform all pregnant women about the benefits and management of breastfeeding.
4. Help mothers initiate breastfeeding within half an hour of birth.
5. Show mothers how to breastfeed, and how to maintain lactation even if they should be separated from their infants.
6. Give newborn infants no food or drink other than breast milk, unless medically indicated.
7. Practise rooming in (allow mothers and infants to remain together) 24 hours a day (Fig. 9.2).
8. Encourage breastfeeding on demand.
9. Give no artificial teats or pacifiers (also called dummies or soothers) to breastfed infants.
10. Foster the establishment of breastfeeding support groups and refer mothers to them on discharge from the hospital or clinic.



Fig. 9.2: Mothers and newborns should be kept together 24 hours a day from birth

- Easing of the hospital burden due to vast savings on infant formula purchase
- Reduction in nursing load as rooming in and demand feeding make nursery care easier.

In India, hospitals are still in the stages of joining this movement. The procedure consists in a candidate hospital improving practices to the point that it follows the “Ten Steps” faithfully. Training the health care providers for successful implementation of the Ten Steps is an important input.

Besides promotion of breastfeeding, baby-friendly hospital initiative in India also proposes to provide:

- Improved antenatal care
- Mother-friendly delivery services
- Standardized institutional support of immunization
- Diarrhea management
- Promotion of healthy growth and good nutrition
- Widespread availability and adoption of family planning.

The baby-friendly hospital initiative has proved an initial step to make hospital facilities more friendly to mother, baby and child. The momentum is gradually picking up.

SCHOOL HEALTH SERVICE

School-going period is relatively safe from health point of view. However, supervision of the health of school children is important. Sound health and its care picked up during these years has a great bearing on the individual, his family and the community for years to come.

Priority Health Problems

Major health problems of school children needing special attention include:

1. Nutritional deficiency states with special reference to mild-to-moderate protein-energy malnutrition, nutritional anemias, xerophthalmia, etc.
2. Infectious diseases
3. Intestinal parasitic (both protozoal and helminthic) infestations
4. Dental caries
5. Skin diseases
6. Eye diseases
7. Ear diseases.

Aims and Objectives

1. Promotion of positive health
2. Prevention of disease
3. Timely diagnosis, treatment and follow-up
4. Health education to inculcate awareness about good and bad health
5. Availability of healthful environments.

Salient Components/Features

1. Health appraisal
2. Remedial measures and follow-up
3. Prevention of communicable diseases
4. Healthful environment
5. Nutritional services
6. First-aid facilities
7. Mental health
8. Dental health
9. Eye health
10. Ear health
11. Health education
12. Education of handicapped children
13. School health record.

An important component of school health program is training the teachers in the basic concepts of hygiene, nutrition, prevention and early detection of morbidities. Teachers can also act as liaison agents between children and health care providers.

JUVENILE DELINQUENCY

By the term, *juvenile delinquency*, is meant indulgence in an offence by a child, precisely a boy under 16 years and a girl under 18 years. Besides such crimes as sexual assault, murder, burglary, theft and inflicting injuries on others, the term includes relatively minor

deviations of youthful behavior, say desertion of family and mixing with antisocial gangs and ungovernable habitual disobedience.

In keeping with the increasing youth unrest over the recent decades, incidence of juvenile delinquency in India is on the increase. Boys are involved 4 to 5 times more than the girls.

Disturbed family conditions, e.g. disharmony between the parents with constant quarrels, divorce, death, poverty, alcoholism, lack of discipline or far-too-much of it, and too many children are the most prominent amongst the causes of juvenile delinquency. Next comes the unsatisfactory conditions at school or college, say lack of adequate recreational facilities, lack of channelization of adolescents' energies, unhealthy teacher-taught relationship, etc. Finally, there is evidence that certain biologic causes like hereditary and chromosomal defects, physical defects and feeble mindedness may be at the bottom of personality disturbance, leading to delinquency.

Prevention should aim at improvement in family conditions so that the child is brought up in an atmosphere of understanding, love and balanced discipline, improvement in the school/college atmosphere with availability of adequate sports and recreational facilities and loving teacher-taught relationship, and provision of child-cum-parents counselling facilities.

For, no one is born with delinquency. The malady is the result of interaction of many a factor related to home environment, school and society. Just because a delinquent fails in his duty to the society, we are not absolved of our duty to him.

MATERNAL AND CHILD HEALTH (MCH)

By the term, *maternal and child health*, is meant promotive, preventive, curative and rehabilitative health care for mothers and children, including maternal health, child health, family planning, school health, handicapped/disabled children, adolescence and health aspects of child care in special settings such as a day-care center.

The concept highlights the vital importance of considering the mother and the child as a single unit. The health of the child is by and large dependent on mother's health and attitudes. During care of the mother, attention to the child (both *in utero* and afterwards) is nearly always mandatory.

Objectives

Specific aims and objectives of maternal and child health include:

1. Reduction in maternal, perinatal, infant and child mortality and morbidity.
2. Promotion of reproductive health, e.g. postponing unwanted arrival of child, adequate spacing between two children and containment of population explosion.
3. Promotion of physical and psychologic development of the child as also adolescent within the family.

Delivery

The overwhelming problems affecting the mother and the child in developing countries at present revolve around the triad of malnutrition, infection and the hazards associated with uncontrolled reproduction / fertility.

The problem of malnutrition may be tackled in two ways. *First*, direct intervention includes such activities as supplementary feeding programs, fortification of food, distribution of iron, folic acid and vitamin tablets, nutrition education, etc. *Second*, indirect intervention includes such measures as control of communicable diseases through immunization, improvement of environmental sanitation; provision of clean drinking water, food hygiene, production of more food, education and primary health care.

Problem of infection in the mother as well as the child needs to be tackled by such preventive measures as immunization of the mother and the child, personal hygiene and appropriate sanitary measures and education of the mother in medical measures like oral rehydration in diarrheal disease and febrile illnesses.

Problem of uncontrolled reproduction/fertility is the root cause of low standard of child health care. There is now a mounting evidence that it contributes enormously to the low birthweight, severe anemia, abortion, antepartum hemorrhage and a high perinatal mortality. The solution lies in bringing maternal and child health/family planning (MCH/FP) services to the doorstep of every household in the form of economic, convenient and safe birth-control devices and provisions for termination of unwanted pregnancies. Introduction of sex education for senior school children (see Chapter 4) is claimed to indirectly contribute to the family planning drive.

Recognizing the importance of tackling the above-said triad of malnutrition, infection and uncontrolled reproduction/fertility, MCH services in India are now offered as a “package” to promote continuity of care and reduce number of visits the mother has to make for herself and for the child.

The components of this *MCH Care Package* include:

1. Antenatal care
2. Intranatal care
3. Postnatal care
4. Perinatal care
5. Nutrition advice
6. Immunization
7. Primary health care
8. Rational family planning.

Mortality Indicators of MCH Care

Mortality indicators employed for assessing the MCH care include:

1. Maternal mortality rate
2. Infant mortality rate
3. Neonatal mortality rate
4. Postneonatal mortality rate
5. Perinatal mortality rate
6. 1 to 4 years mortality rate

Maternal mortality rate (MMR) It is defined as deaths per 1,000 live births of women while pregnant or within 42 days of termination of pregnancy, irrespective of the duration and the site of the pregnancy, from any cause related to or aggravated by the pregnancy, or its management, but not from accidental or incidental causes.

The causes of maternal mortality may be direct obstetrical complications or indirect obstetrical complications which developed during or existed before pregnancy or which get precipitated/aggravated by physiologic effects of pregnancy. Toxemias of pregnancy, hemorrhage, sepsis and illegal abortions constitute leading causes of high MMR in India (5 to 8 against just 1 in Sri Lanka and 0.1 to 0.3 in developed countries).

Infant mortality rate (IMP) It is defined as deaths per 1,000 live births of infants who have not attained age of 1 year. Infant mortality is considered as a most sensitive index of the health and level of living of a people.

Neonatal mortality or early infant mortality means infant mortality which occurs within the first 28 days

of life. Its causes include immaturity, birth injury and difficult labor, congenital anomalies, placental and cord anomalies, diarrheal disease and acute respiratory infection.

Postneonatal mortality or late infant mortality means infant deaths which occur in 1 to 12 months of age. Whereas neonatal mortality is usually due to prenatal and natal causes, postneonatal mortality is due to environmental influences like diarrheal disease, acute respiratory infection (pneumonia, influenza), communicable disease (pertussis), malnutrition, congenital anomalies and accidents.

In India, IMR at the turn of the present century was over 200. By 1982 it was 110 and by 1985 it dropped to 95. It is estimated to be around 55 in 2008. This rate is quite high when compared to the current figures of 16 in Sri Lanka, and 4 to 10 in European Countries. India's aims of reducing its IMR to below 60 by the year 2000 AD had apparently misfired, primarily because of high neonatal and perinatal mortality.

In order to achieve this target, a multipronged aggressive attack with spotlight on the following areas is needed:

1. Improvement in the nutritional status of the pregnant women.
2. Immunization of pregnant women against tetanus.
3. Family planning.
4. Efficient MCH services
5. Improvement in living standard
6. Promotion of breastfeeding
7. Health education of the mother about child care.

Perinatal mortality rate (PMR) It is defined as the fetal deaths between 28th week of pregnancy and the end of the first week after birth per 1,000 live births plus stillbirths. Recently, it has been suggested that a birthweight of 1,000 g may be substituted for gestational age of 28 weeks. It has also been suggested that where only live births are counted, the sementic, *perinatal mortality ratio*, should be employed.

Though a large number of prenatal, intranatal and postnatal factors are known to cause perinatal mortality, the situation in India and other developing countries is more or less monopolized by such causes as low birth-weight, birth trauma, congenital malformations and neonatal infections.

The estimated PMR now in India is around 30 which too has fallen much short of the target of 30-35 for 2000 AD. In developed countries, the rates vary between 8 and 20.

Nothing short of concerted efforts for improving the prenatal care with special emphasis on mother's diet, avoidance of infections and other harmful influences, efficient obstetric services and efficient neonatal services would lead us to our stated goal of reducing perinatal mortality to the minimum.

One to 4 years mortality rate It is defined as the mortality per 1,000 of children in 1 to 4 years age group. Mortality in this age group depends on the immediate environment including economic, educational and cultural characteristics of the family and the community rather than on perinatal hazards and other endogenous factors.

Under-5 mortality rate It is defined as the number of deaths of children under 5 years of age per 1,000 live births. This is the basic measure of infant and child survival, indicating probability of dying between birth and exactly 5 years of age. The 2006 under-5 mortality rate in India is 76, in Afghanistan 257, in Pakistan 97 and Bangladesh 69. The corresponding figures in case of Sweden and Japan are just 3 and 4 respectively.

Child-survival rate This is calculated by simply subtracting the under-5 mortality rate from 1,000 and dividing the resultant figure by 10. Child survival rate for India is, therefore, 88.0, and for Sweden 99.5.

INTEGRATED CHILD DEVELOPMENT SERVICES (ICDS) SCHEME

This scheme, first introduced in 1975 on experimental basis in the form of 33 projects, has now over 5,000 projects. It is targeted at holistic development of children.

Objectives

1. To improve the nutritional and health status of children in the age group 0 to 6 years.
2. To lay the foundation for proper psychologic, physical and social development of the child.
3. To reduce the incidence of mortality, morbidity, malnutrition and school dropout.
4. To achieve effective coordination of policy and implementation amongst the various departments to promote child development.
5. To enhance the capability of the mother to look after the normal health and nutritional needs of the child through nutrition and health education.

Package of Services

A. Essential

1. Supplementary nutrition
2. Immunization
3. Health check-up
4. Referral services
5. Nutrition and health education
6. Nonformal education

B. Supplementary

1. Nonformal education of adult women
2. Applied knowledge about increased local production and consumption of nutritious foods
3. Rural drinking water supply.

Beneficiaries of Services

The major beneficiaries of ICDS are children under 6 years of age and pregnant and lactating mothers. Besides, women in the age group 15 to 44 years are also included. Thus, beneficiaries constitute over 40% of the total population. The scheme is jointly operated by the Ministry of Health and Family Welfare and Ministry of Women and Child Development. The services offered to different categories of beneficiaries are shown in the Table 9.2.

ICDS scheme ought to be viewed as a vital drive against poverty and as an instrument to improve the health, nutritional and educational status of the under privileged children and mothers as a part of India's 20-point development plan. What is remarkable is that, according to conservative estimates, it will cost less than even 1% of the gross domestic product of the country.

Delivery of Services

The services are delivered at a community center, the *anganwadi* (meaning a courtyard). *Anganwadi worker* is the backbone of the center. She comes from a local community and has had 4 months training in fundamentals of child development, nutrition, immunization, personal hygiene, environmental sanitation, antenatal care, breastfeeding, identification and immediate management of at-risk children, treatment of common day-to-day illnesses, preschool education and functional literacy and simple recordkeeping. In each urban ICDS project, *anganwadi worker* must at least be a matriculate but that is not necessary for rural and tribal projects.

Table 9.2: Services available to different categories of beneficiaries scheme

Beneficiary	Services
Children under 1 year	– Supplementary nutrition – Immunization – Health check-up – Referral services
Children of 1 to 3 years age group	– Supplementary nutrition – Immunization – Health check-up – Referral services
Children of 3 to 6 years age group	– Supplementary nutrition – Immunization – Health check-up – Referral services
Expectant and nursing mothers	– Nonformal preschool education – Health check-up – Immunization against tetanus of expectant mothers – Supplementary nutrition – Nutrition and health education
Other women of 15 to 44 years age group	– Nutrition and health education

The AWW is assisted by a local person, usually an uneducated and unskilled woman.

The work of AWW is supervised by *mukhyasevika*. She is a graduate and has had 2 months special training.

The *Child Development Project Officer (CDPO)* supervises the work of *mukhyasevikas* and is in charge of each ICDS project. He is, preferably a graduate in child development, social work, home science, nutrition or any allied field and has had 2 months special training.

The ICDS scheme is under the administrative control of the Social Welfare Ministry of the Govt of India. At the State level too, social welfare is the administrative ministry in a vast majority of the States. In rural projects, the services are strengthened by the primary health centers whereas in the urban ones, medical colleges make outstanding contributions. Training consultants (drawn from community medicine or pediatrics) provide services related to training, survey and research.

Community Participation

All attempts must be made to explain different components of the program to the community so that people feel involved in it. Community needs to be

1 involved through local health committees in the preparation of nutritious food mix for supplementary nutrition, using local foods, immunization, vitamin A, iron and folic acid supplementation, etc. *Mahila Mandals* can play valuable role in ICDS activities.

The major thrust of ICD scheme at present is to achieve a convergence between sectoral services of various departments involved in the upliftment of underprivileged sections of the community. Anganwadi workers are expected to play a significant role in this endeavor.

CHILD LABOR

Child labor may be defined as employment of children in gainful occupations even at the expense of their physical, emotional and social wellbeing. "Labor" should, for the purpose of this definition, be interpreted as "work" that the child does outside his own family circle and for which he, in turn, receives wages. Work in this case is such as requires strength or patience rather than skill or training.

Magnitude of the Problem

According to a conservative estimate, some 70 million* children are engaged in child labor in the world. What is remarkable, 98% of them are in the developing countries. The Anti-Slavery Society believes the number may well be much more than 100 million since in many countries child labor may be clandestine and children who both work and attend school are rarely considered as child workers.

India has the largest force of child laborers in the world, about 90% of them being in rural areas. Every third house has a working child. Every fourth child is employed. In India's capital alone, 5,00,000 children are estimated to be working in shops or dhabas, as domestic servants, or street children (rag-pickers, for instance).

Major Patterns of Child Labor (Figs 9.3 to 9.5)

- i. *Unorganized sector* A vast majority of the child labor force is in the unorganized sector— agriculture work, as shoeshine boys, rag-pickers, newspaper vendors, cigarette vendors, helpers in shops and small wayside restaurants or petty servants' for running errands in private homes.
- ii. *Organized sector* Only a small proportion of working children are in the real organized sector.

In actuality, it is the semiorganized sector—carpet weaving, sari embroidery, brassware, precious stone polishing, bidi making, bangle manufacturing, leather tannery, match and firework manufacturing, construction work, gas stations, petrol pumps, automobile workshops, autogarages, etc. which monopolize the situation.

All said and done, remember that the largest number of working children are found in households, frequently helping adults in household chores or providing baby-sitting for the younger siblings. Next comes the nondomestic work—usually agricultural in nature.

All sort of work under the eponym "child labor" nearly always discourages school attendance.

Background Factors

Poverty is the single most important factor responsible for child labor.

Exploitation by the parents, who have selfish motives in wanting their children to work rather than go to school is often the operative cause.

Remaining factors operating in child labor include exploitation by the employers, bad company, begging gang, school dropout, child-out-of-wedlock, maladjustment in the family, death of parent(s) and juvenile delinquency.



Fig. 9.3: Child labor. A Nepalese adolescent engaged in strenuous manual work at a construction site



Fig. 9.4: Child labor. An instance of street children who collect “garbage” the whole day and are banked upon as bread-earners for the family



Fig. 9.5: Child labor. One of millions of working children who rakes through garbage dumps for polythene bags, plastic and waste paper for a living

Health Hazards

Environmental hazards The working child is exposed to such adverse factors as dust, smoke, lighting, radiation, unsafe and unhygienic conditions—to mention just a few—all of which threaten his health.

Drug abuse Child laborers are frequently exposed to smoking, boozing and drugs which eventually lead to addiction and far-reaching damage to child’s health.

Venereal diseases Child prostitution and sexual exploitation may lead to venereal diseases.

Accidents and injuries Incidence of injuries while working is quite high. The leading causes include lifting of heavy weights, broken glasses, slipping or falling, and injuries caused by various materials and machinery.

Communicable diseases There is evidence that the working children have much higher incidence of communicable diseases such as tuberculosis, leprosy and VD.

Malnutrition Poor nutrient intake in relation to increased needs, more so as a result of increased manual work, adversely affects the normal growth spurt during puberty and adolescence.

Psychosocial development Restricted social interaction with denial of leisure, play and recreation, and long hours of daily work leave crippling effect on child’s emotional development. With exposure at a premature age to adult life of brawls, sex, boot-logging, crime and what not, he is thrown into life, incredibly precocious beyond his years.

Little wonder, smoking, drug addiction, smuggling and even prostitution are common in working children. Juvenile delinquency is very high in such children.

High morbidity Magnitude of ailments, say headache, backache, cold, cough, fever, conjunctivitis, scabies, pyodermas, nutritional deficiency states, tuberculosis, intestinal parasitic infestations, diarrheal disease, accidents, etc. is far higher in child laborers. More than the work, the working conditions are harmful to the health.

Table 9.3 lists the health hazards in relation to type of labor.

The Way-out

Child labor is closely connected with the socioeconomic status of the deprived communities. Since banning it, though eventually needed, is neither workable nor desirable at present in view of widespread poverty and bad economy, the thrust right

Table 9.3: Health hazards in child labor

Type of labor	Health hazard(s)
Agriculture	Injuries from accidents. Heat-induced problems. Dermatitis from fertilizers, pesticides or herbicides Snake bite, etc. Parasitic infections
Carpet-making	Lung problems from inhalation of fiber dust. Poisoning from coloring agents
Balloon factory	Lung problems including pneumonia. Heart failure
Bidi industry	Nicotine poisoning in the form of easy fatigability of muscles, nausea, headache, blackouts, blindness
Powerloom industry	Lung problems like byssinosis and tuberculosis
Firework/match industry	Lung problems Burns Muscle fatigability Deformities
Zari industry	Eye problems Spinal problems Deformities
Glass industry	Heat stroke Lung problems Conjunctivitis Reduction in life span
Lock industry	Lung problems, including asthma Acid burns Headache
Brass industry	Lung problems Acid burns
Slate industry	Silicosis Pneumoconiosis Tuberculosis
Domestic work	Fatigability Child abuse and neglect (CAN) Drug abuse
Prostitution	Venereal diseases AIDS Hepatitis

now should be on elimination of child labor related to exploitative and hazardous works, and to bring health services where they work through a strategy involving the parents, employees, community, and nongovernmental, governmental and voluntary agencies.

The highlights of *The Child Labor (Protection and Regulation) Act, 1986*, in our country are listed in Table 9.4.

Disillusioned by the worsening child labor scenario in India, the Supreme Court of India on 8th December, 1996, directed all State Governments and Union Territories to take concrete steps to abolish child labor. It identified nine industries for priority action and

Table 9.4: Main features of The Child Labor (Protection and Regulation Act 1986)

1. No child who has completed his 12th year and no adolescent shall be required or allowed to work in any plantation unless (a) a certificate of fitness granted with reference to him under Section 27 is in the custody of the employer, and (b) such child or adolescent carries with him, while he is at work, a token giving a reference to such certificate.
2. No child shall be required or permitted to work in any establishment in excess of such number of hours as may be prescribed for establishment.
3. The period of work on each day shall be fixed in a way that no period shall exceed three hours before he has had an interval for rest for at least one hour.
4. The period of work should be so arranged that, inclusive his interval for rest under subsection 2, it shall not spread over more than six hours including the time spent in waiting for the work on any day.
5. No child shall be permitted or required to work between 7 PM and 8 AM.
6. No child shall be required or permitted to work overtime, etc.

directed setting up of Child Labor Rehabilitation Welfare Fund. The offending employers are supposed to pay for each child a compensation of Rs. 20,000 to be deposited in the Fund.

The Indian Academy of Pediatrics (IAP) Committee on Child Abuse, Neglect and Child Labor (CANCL) is now engaged in formulating an ambitious country-wide strategy to fight the malady.

STREET CHILDREN

As many as 100 million children across the globe, with dominant concentration in Asian, African and Latin American countries, live and work on streets, usually without support from families.

Major factors contributing to this malady are poverty, rapid urbanization, loss of family members through disease, accidents or disasters, physical and sexual abuse, etc.

Street children (Fig. 9.6) are specially at risk of developing nutritional deficiencies, tuberculosis, STDs, HIV, substance abuse, skin disorders, intestinal parasitosis, prostitution and criminal exploitation.

The governmental and nongovernmental organizations (NGOs) need to intensify efforts to improve their lot through:

- Provision of health and welfare services
- Housing opportunities



Fig. 9.6: Street children

- Educational facilities
- Employment
- Adoption
- Rehabilitation centers.

THE HANDICAPPED CHILD

The term, *handicap*, refers to an inability to achieve the full potential or fulfill a role that is normal for that individual as a result of disease, impairment or disability. It is the effect of the conditions.e.g. inability to participate in competitive sports like hockey, cricket or skating in post-polio lameness, or social isolation resulting from mental retardation, deafmutism or epilepsy.

Disease, on the other hand, simply refers to a specific health problem like cleft palate, arthritis or congenital heart disease.

Impairment refers to any loss or abnormality of psychological, physiological or anatomical structure or function like autism, impaired vision or loss of a limb in an accident.

Disability refers to an inability to carry out certain activities considered normal for the individual's age, sex, etc. as a result of impairment.

Figure 9.7 gives the sequence of events leading to a handicap.

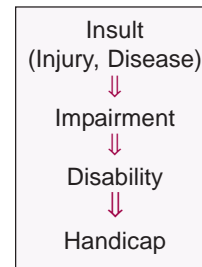

Fig. 9.7: Sequence of events leading to a handicap

According to a conservative estimate, 10% of India's population is handicapped in one way or the other. Thus, there are about 45 million handicapped children in the country at present. Worldwide, there are about 400 million handicapped children.

Etiologic Classification

Communicable diseases, perinatal insult, PEM and accidents together account for 75% of the handicap in childhood. Table 9.5 presents the detailed etiologic classification of pediatric handicap.

Management

Disability Intervention/Limitation

The aim is to safeguard against or, at least, halt the progression of the disease process from impairment to disability and handicap. This can be achieved by two major strategies, namely:

- Medical intervention during impairment, the earliest stage, and
- Social and environmental intervention in terms of dependence and social cost for the disability and handicap, the later stages.

Disability Prevention

This relates to all the three levels of prevention, namely:

- Primary prevention by reducing the occurrence of impairment through vaccination as in poliomyelitis,
- Secondary prevention by disability limitation through suitable treatment as in rheumatoid arthritis,
- Tertiary prevention by preventing the transition of disability into handicap as in rehabilitation through psychosocial, vocational and medical components.

Table 9.5: Etiology of pediatric handicap

A. <i>Physical (Orthopedic)</i>
Sequelae of fractures, arthritis, etc.
Residual rickets
Chondrodystrophies
B. <i>Neurologic</i>
Mental retardation
Behavioral/learning disabilities
Postpolio residual paralysis (PPRP)
Postmeningitic, encephalitic sequelae
Cerebral palsy
Epilepsy
Degenerative disorders
Birth defects
C. <i>Sensory</i>
Visual: Blindness (partial or complete), refractory errors
Auditory: Deafmutism, partial hearing loss
Speech: Dysarthria, stuttering, dysphonia
D. <i>Chronic Systemic Diseases</i>
Heart disease (both congenital and acquired)
Bronchial asthma
Diabetes mellitus
Malabsorption syndrome
Muscular dystrophy
E. <i>Social</i>
Child abuse and neglect (CAN)
Drug addiction
Orphan

Rehabilitation

Rehabilitation of the handicapped aims at training and retraining of the individual to the highest possible level of functional ability through combined and coordinated use of medical, social, educational and vocational measures. The eventual goal is to reduce the fallout of disabling and handicapping conditions, enabling the individual to actively participate in the mainstream of the community, the so-called "social integration". The process of rehabilitation involves restoration of function (medical rehabilitation), restoration of capacity to earn livelihood (vocational rehabilitation), restoration of the family and social relationship (social rehabilitation) and restoration of personal dignity and confidence (psychological rehabilitation). Naturally, a multitude of subdisciplines are required to participate in this process, including physiotherapy, occupational therapy, speech therapy, audiology, psychology, education, social work, vocational guidance and placement services.

Services for the handicapped must incorporate therapeutics, education, and social and emotional support to the family. Nothing short of community participation will make these services effective. The areas of community participation include case reporting and referral to the rehabilitative services, raising funds for maintenance of these services, and advisory role for planning and administration. In addition, the community should act as a "pressure group" for promoting social legislation for the disabled. The community needs to offer employment opportunities in shops, factories, and other business establishments to the disabled.

Central to all welfare programs is "awareness creation" in the society about the abilities of a child with a handicap. There are many a myth about the handicapped. We must put up concerted efforts with support from the mass media (radio, television, press, etc.) to "demythify" disability and put a thrust on positive approach to child with a handicap.

Available Welfare Services at National Level

The following institutes are set up by the Government of India as premier institutes in their respective fields to cater to the needs of the handicapped in the area of education, development of manpower, training, vocational guidance, counselling, research, development of suitable service models and low cost aids and appliances:

1. National Institute for Orthopedically Handicapped, Calcutta.
2. National Institute for Mentally Handicapped, Hyderabad.
3. Ali Yavar Jung National Institute for the Hearing Handicapped, Mumbai.
4. National Institute for the Visually Handicapped, New Delhi.
5. Institute for the Physically Handicapped, New Delhi.
6. National Institute for Rehabilitation, Training and Research, Cuttack.

THE GIRL CHILD

(Gender Bias, Gender Gap, Discrimination against Females)

In India and rest of the Third World, not only the girl child but the woman as such continues to be

discriminated. The sex bias is far more pronounced among the downtrodden and the rural settings. The discriminated girl child, if she manages to survive, grows up to show discrimination to her female children. This vicious cycle goes on and on and is hard to break.

Currently, we are in the thick of a campaign to generate awareness among people for safeguarding the rights of the girl child and for upliftment of her status. This will eventually have a positive bearing on the status of the woman as well.

Every year, 18-24 September is observed as *Girl Child Week* throughout India.

Issues and Problems (*Female Feticide / Infanticide*)

Discrimination against the girl child begins even before her birth. The so-called “sex-determination shops” are having roaring business, offering amniocentesis and ultrasound facilities for finding the unborn baby’s sex and indirectly instigating abortion of the female fetus. The practice attracts clients from all socioeconomic groups, even if the money has to be begged or borrowed. Now, there is a legal ban on abortion of female fetus following sex-determination tests. However, the practice is going on, though illegally, under a garb such as MTP. There truly is an unholy nexus between the parents, their advisers, sex-determination clinics and abortionists.

Birth of a girl is often received with indifference and apathy, at times a reaction akin to “mourning”.

Nutritional Status

On an average, nutritional status of the girl child is poorer than that of the boy. She is more likely to have low birthweight and more likely to be given artificial feed. She is provided less amount of food which again is of inferior quality as compared to a boy. Often, it is a practice to postpone onset of puberty in a young girl by restricting her food intake so that parents can buy sufficient time to arrange dowry and a suitable groom for her.

Morbidity and Mortality

The medical needs of the girl child too are ignored. While the biologic truth is that more males die in infancy than females, in India the reverse holds good. The National average for female: male ratio in India

in 1981 was 933:1000. It fell down to 929:1000 in 1991, and is estimated to be 927:1000 in 2000.

Educational Status

Educating the girls is hailed as the best investment a nation can make for its bright future. Yet, education of girls in India presents a sordid picture. Quite a proportion of girls never get enrolled in schools. Those who do so show a high rate of dropout. Among the factors that contribute to female illiteracy figure cultural, historical and social constraints, in addition to lack of ample schools, lack of female teachers, an antipathy to coeducation, and child and teenage marriage. Often, girls are not sent to school because they are required to participate in household chores (Fig. 9.8). Many parents do not wish to allow girls to get exposed to modern ideas to ensure that they remain docile and submissive.

Female illiteracy contributes to innumerable problems related to family welfare.

Girl Child Abuse and Neglect

The girl child is particularly subjected to considerable exploitation and abuse. She is denied very survival, adequate food intake, education, health care, etc. She is brought up to be submissive and docile, playing second fiddle to the brother. Her attitudes are moulded in such a manner that she herself gets gravely biased against her own gender. When she becomes a mother, her treatment to daughters and daughters-in-law



Fig. 9.8: In developing countries, household responsibilities keep millions of girls out of school. To quote the UNICEF, “this invisible barrier needs to be broken to assure their right to education”

becomes a reflection of this unhealthy bias. The custom of “devdasis” and “yallamas” is a sad commentary on the society.

Girl Child Laborer

In India alone, there are around 8 million working female children. Out of these, some 2 million are engaged as domestic servants.

Girl child laborers are more exploited than their male counterparts. They are paid less and asked to do more work. This contributes to their poor state of health, nutrition and wellbeing.

Girl Street Child

The girl street child is much worse than her boy counterpart. She is harassed, sexually abused and often pushed into prostitution.

The Solution/Practical Action Plan

1. There should be no discrimination on the basis of sex. Girls should be given equal opportunities.
2. A total ban on female feticide in all States and Union Territories needs to be implemented strictly.
3. Awareness of importance of various aspects of the girl child, e.g. education, legal status, etc. needs to be emphasized thoroughly through circulars in various local languages, Posters/cartoons at prominent parts of localities, television/radio skits, and street plays, discussions/seminars by local bodies at all levels to ensure participation at grassroot level.
4. Education of girls should be the priority: Free education of all girls up to secondary school level in all the States of India. Nonformal adult education, especially for women, should be taken up on a war-footing simultaneously.
5. Improvement of nutritional status:
 - a. Midday school meal program should be introduced in the municipal and government-aided schools.
 - b. A special supplementation program should be designed for the severely malnourished children.
 - c. Vitamin D supplementation should be given as per the need in the community to prevent rickets, especially in girls.
6. Compulsory immunization
7. During home visits by the community health workers, stress should be laid on the health status of the girls who may otherwise be neglected by their families.
8. Child Labor Act and laws pertaining to exploitation of children, especially girls, should be revised, simplified and implemented, especially in regard to sexual exploitation.
9. Motivation of adoption of girl children and especially handicapped ones, needs to be stressed. Mass adoption of girls either from a school or a community by a voluntary organization or an industrial one should also be promoted.
10. Handicapped and socially deprived girls should be given job opportunities on a preferential basis.

PREVENTION OF ACCIDENTS

According to the World Health Organization, an accident is an event, independent of human will, caused by an outside force acting rapidly and resulting in bodily or mental injury. The occurrence of injury is unintended. Majority of accidents are preventable.

Magnitude of the Problem

Accidents are undoubtedly among the chief causes of morbidity and mortality in childhood and adolescence in the Western countries. Though in India and other developing countries, the priority health problems are diarrheal disease, malnutrition and infections, the accidents too are quite frequent—especially the domestic ones like burns, injuries, poisoning, and traffic mishaps.

Major Types

Accidents may be classified into the following five categories:

1. Accidents Requiring Medical Intervention: Drowning, burns, falls, cuts and wounds, agro-industrial injuries, animal bites (dogs, snakes, etc.) — Common poisoning, especially insecticides rodenticides, kerosene oil, drugs, etc.
2. Accidents Requiring Surgical Intervention/ Observations: Head injuries, burns, soft tissue injuries (faciomaxillary injuries), fractures, trauma to abdominal organs, miscellaneous
3. Accidents Involving Eyes: Bow and arrow, Gullidanda, fireworks (anar), stone throwing,

broom stick and other sticks, sharp-edged toys, balls, shuttle-cocks, fist fighting, fall from a height, knife, scissors, needle, Chemical, thermal

4. Accidents Involving ENT: Foreign bodies, roadside accidents, corrosive poisoning (kerosene oil), sudden exposure to noise, causing sudden deafness, physical injuries (slap), mechanical injuries with sharp objects, strangulation from clothes being entangled in rotary machines, automobiles, etc, kite-flying, causing laryngo-tracheal cuts, loss of pinna, etc.
5. Road/Traffic Accidents: Reversing car, careless road crossing, playing in streets with vehicular traffic, allowing children to stand in a car, or, still worse, to sit in driver's lap.

Preventive Measures

Accident prevention needs three things. *First* is the forethought which means to anticipate the possible risk to the child. *Second is time* in order to watch the child and his activities. *Third is discipline* which should be well balanced.

Education

Education can play as great a preventive role in accidents as vaccination in disease prevention. It should be imparted to the parents, school teachers and grown-up children.

Strict Implementation of Rules

- Traffic rules, such as compulsory wearing of crash helmets, restriction of the speed to recommended limits, checking of blood alcohol level of drivers, regular checking of vehicles, etc. must be strictly enforced. It is suggested that seat belts should also be made compulsory for car riders—the driver and the user of the front seat, in particular. Also, regular caution needs to be exercised in issuing driving licences. A driving licence should bear the blood group of the owner.
- Children must not travel on the front seat of the car.
- Condition of roads must be up to the mark
- Every crossing and every vehicle must have first aid facilities and every driver must be familiar with first-aid administration before being issued a licence.

Elimination of Causative Factors

Reduction in accidents can be successfully attained by eliminating the factors that are likely to cause them. The remedial measures in this behalf can be in the form of improvement of housing, safe storage of drugs and poisons, improvement of roads, proper placement of electric points, etc.

Medical Care of the Victim

Many deaths can be prevented if accident victims are provided emergency care at the accident site, during transportation and in the hospital emergency room.

Police must not harass the people who contribute in transporting an accident victim to the nearest hospital or doctor.

It is advisable to provide the traffic constables, a two way walkie-talkie to speed up the process of medical help.

Every medical college must have a comprehensive trauma care and rehabilitation unit.

Survey and Research

Studies need to be undertaken about the causes, extent, type and other characteristics of accidents as also determining new ways and means of making the environment safer and changing human behavior for controlling accidents.

CHILD ABUSE AND NEGLECT

The spectrum of child maltreatment encompasses acts of abuse or commission and acts of omission or neglect/lack of appropriate action by a caretaker, resulting adverse effects and even mortality in children. The following factors contribute to higher incidence of such maltreatment in groups living in poverty:

- Enhanced number of crises in their lives in the form of unemployment, overcrowding and disease.
- Limited reach to social and economic resources for support during times of stress.
- High rate of violence, teenage pregnancy, single parenthood and drug abuse (all risk factors).
- Higher reporting because of more scrutiny by social agencies.

Discussed in details elsewhere, the malady needs to be fought by a multipronged strategy, including awareness activities. The IAP Committee on Child Abuse, Neglect and Child Labour proposes to evolve such a program.

INDIA'S NATIONAL HEALTH PROGRAMS

Various national health programs, currently in operation, are listed in Table 9.6.

Reproductive and Child Health (RCH) Program

This program followed revisions in the CSSM Program as per recommendations made at the International Conference on Population and Development in Cairo in 1994 and was born in 1997. Its goals are removing all targets for family planning, phasing out incentive payment to both providers and acceptors of family planning methods, increasing utilization of existing facilities and using the voluntary and private sector to enhance access to services and fill gaps left by public sector providers.

The package of services offered by RCH program are:

For the Children

- Essential newborn care
- Exclusive breastfeeding
- Immunization
- Appropriate management of ARI
- Vitamin A prophylaxis
- Treatment of anemia

Table 9.6: India's national health programs

1. National Malaria Eradication Program
2. National Family Welfare/Planning Program
3. National Tuberculosis Control Program
4. National Leprosy Control Program
5. National Filaria Control Program
6. Iodine Deficiency Control Program
7. National Water Supply and Sanitation Program
8. National Program for Prevention of Visual Impairment and Control of Blindness
9. Diarrheal Disease Control Program
10. STD Control Program
11. Universal Immunization Program
12. Minimum Need Program
13. 20-Point Program
14. Guinea worm Eradication Program
15. National Diabetic Control Program
16. National AIDS Program
17. Child Survival and Safe Motherhood (CSSM) Program
18. Reproductive and Child Health (RCH) Program.

For the Mother

- Tetanus toxoid immunization
- Prevention and treatment of anemia
- Antenatal care and early identification of maternal complications
- Deliveries by trained personnel
- Promotion of institutional deliveries
- Management of obstetrical emergencies
- Birth spacing

For the Eligible Couples

- Prevention of pregnancy
- Safe abortion

For RTI/STD

- Prevention and treatment of reproductive tract infection and sexually-transmitted diseases. RCH program is a target-free program with voluntary participation.

INTEGRATED MANAGEMENT OF NEONATAL AND CHILDHOOD ILLNESS (IMNCI) STRATEGY

This WHO/UNICEF designed new strategy is inspired by the common observation that in developing countries illness usually strikes as a group rather than as a single disease, say diarrhea or respiratory infection. In addition, anemia, malnutrition and poor immunization coverage often go unaddressed although these are known to commonly accompany these illnesses. Here, therefore, the focus in an integrated manner, is on main causes of morbidity and mortality as also the overall health of the child. Three remarkable components of the strategy are:

- Improvement of the case management skills of health providers through provisions of locally adapted guidelines and training activities to promote their use. Guidelines on referral criteria are quite an important component of the algorithm.
- Provision of essential drug supplies required for effective case management of childhood illness.
- Optimization of family and community practices in relation to child health, particularly care-seeking behavior.

In India, IMCI has been expanded to include neonatal care. Hence, it is rechristened Integrate Management of Neonatal and Childhood Illness (IMNCI) and made central pillar of the child health strategy under RCH-II/National Rural Health Mission (NRHM).

Three major components of IMNCI are:

1. Improvement in case-management skills of health staff through appropriate guidelines.
2. Improvement in the overall health system, and
3. Improvement in family and community healthcare practices.

Principles of IMNCI Guidelines

1. All sick young infants up to 2 months of age must be assessed of “possible bacterial infection/ jaundice” and “diarrhea”.
2. All sick children aged 2 months up to 5 years must be examined for “general danger signs” and then for cough or difficult breathing, diarrhea, fever or ear problems.
3. All sick young infants and children aged 2 months up to 5 years must also routinely be assessed for nutritional and immunization status, feeding problems and other potential problems.
4. Only a limited number of carefully-selected clinical signs of high sensitivity and specificity are used.
5. Based on the signs, the child is assigned to color-coded classification: “pink” suggests hospital referral/hospitalization, “yellow” indicates specific treatment and “green” calls for home treatment.
6. *Guidelines address most but not all health problems.*
7. Management procedures use a limited number of essential drugs and encourages active participation of caretakers who need counseling about home care, including feeding, fluids and follow-up visit(s).

Steps of Management

- Step 1: Check-up to identify the illness
 Step 2: Classification of illness according to color-coded charts
 Step 3: Advise retreatment/referral/ home management (including counseling)
 Step 4: Follow-up.

INDIA'S NATIONAL NUTRITION PROGRAMS

Refer Chapter 11 (Pediatric Nutritional Requirements).

INDIA'S NATIONAL NUTRITION POLICY

Refer Chapter 13 (Protein-energy Malnutrition).

ADOPTION

Refer Chapter 42 (Miscellaneous and Unclassified Issues).

ACUTE FLACCID PARALYSIS (AFP) SURVEILLANCE

The strategy aims at identifying cases of AFP (polio, Guillain-Barre syndrome, transverse myelitis, traumatic neuritis) and reporting them to the District Immunization Officer of the area for further action. For details, see Chapter 18 (Pediatric Viral Infections)

TELEVISION AND THE CHILD

A Boon

Undoubtedly, television has become a part and parcel of our life. Like adults, children too watch it for entertainment, information, reassurance and comfort after stressful experience, overcoming boredom, etc. Educational TV programs can enhance the cognitive development of children, especially the preschoolers, in reading, readiness and acquisition of vocabulary. For older children, it is an excellent source of current events, science, history and politics. Suitably chosen programs are capable of supplementing parents' activities aimed at inculcating knowledge, skills, information and motivation for learning.

Agewise TV Viewing

Experience has shown that children start consistent TV viewing between 2 to 3 years of age. A child of 4 to 5 years may not be able to fully understand a program but he does form some impression of what he has viewed. Of course, he cannot differentiate between fantasy and real happening clearly. To him everything on TV is true to life. A violent scene could be as terrifying to him as violence in real life.

Between 8 and 12 years of life, child's understanding of TV improves considerably. Now, he is able to draw conclusion from certain programs. There is a considerable improvement in memory for program contents.

The adolescent has a tendency to become increasingly critical of the TV programs. He, therefore, becomes choosy too.

1 Adverse Effects

Among the probable adverse effects of excessive or erratic TV viewing rank the following:

- Infringement on child's time meant for studies, play, sports, hobbies, etc.
- Much-too-much of snack-eating during TV watching and reduction in activity, resulting in obesity.
- Adolescent delinquency and violence secondary to viewing of violent TV programs.
- Behavioral problems secondary to violent, horror or adult programs.

The Way-out

- Parents must use their balanced judgement in choosing TV programs for the child.
- Parents must assist children through interaction to drive sensible and positive interpretations from the programs watched by them.
- Parents must introduce children to hobbies and alternate channels of recreation so that they build relationship to the world around them rather than to the TV set.
- Schools should play a positive role in utilizing creative and beneficial aspects of TV. Recognizing the value of TV as the "third parent", the Indian Academy of Pediatrics is striving to have a Kaleidoscopic Innovative Doordarshan (KID) channel which would exclusively present programs that children like to see and which parents, teachers and caretakers want children to see.

DISPOSAL OF HOSPITAL WASTE

The Ministry of Environment and Forests, Govt. of India, has done well to notify the *Biomedical Waste (Management and Handling) Rules 1995*. According to these rules, the biomedical wastes are to be handled

as per the prescribed procedures which specify authorization/responsibility of generators and operators, segregation, packaging, transportation and storage, treatment and disposal, maintenance of records and returns, accident reporting and follow-up, and import and export methods for biomedical wastes. All hospitals and nursing homes have been directed to install incinerators/suitable devices for safe disposal of human anatomical waste (tissues, organs, body parts), blood and body fluids and items saturated or dripping with blood and body fluids. The authority for execution of the provisions is entrusted to the State Pollution Control Boards.

FURTHER READING

Articles/Chapters

1. Banerjee SR. Child labor. In Gupte S (Ed): *Recent Advances in Pediatrics*, Vol 2. New Delhi: Jaypee 1992:134.
2. Ghosh S Lesser sex: discrimination from womb to tomb. In Gupte S (Ed): *Recent Advances in Pediatrics*, Vol 4. New Delhi: Jaypee 1994:414.
3. Gupte S. Child labor: How long will the "little people" continue to be exploited? In Gujral VV, Narayanan I, Dutta A (Eds): *The Underprivileged Child*. New Delhi: Sagar Publications 1981:161.
4. Gupte S. Child labor. *Indian Padiatr* 1987;24:177.
5. Gupte S. Child labor: some reflections. *Acad Today* 2006:
6. Rohde JE. The Baby-friendly Hospital Initiative: India's role in the global movement. In Gupte S (Ed): *Recent Advances in Pediatrics*, Vol 3. New Delhi: Jaypee 1993: 334.

Books/Monographs

1. Gupte S. Recent Advance in Pediatrics (Special Vol 11: *Community Pediatric*). New Delhi: Jaypee 2001.
2. Rural Health Mission. *Students' Handbook IMNCI* New Delhi: Ministry of Health and Family welfare Government of India 2007.

CHAPTER



Immunization

Suraj Gupte

INTRODUCTION

Immunization programs form the sheet anchor of the preventive services available today. These aim at preventing disease by producing controlled clinical reactions which are likely to confer effective and, as far as possible, lasting resistance to infections, the so-called *immunity*.

Unfortunately, effective vaccines are not being used on a scale that is needed to provide tangible results. Studies clearly indicate that the immunization status of our pediatric population is as yet far from adequate. Surely enough, the picture in other developing countries is not significantly different. This explains why, while in the affluent countries infectious diseases have gone down in the mortality list, these continue to be a major factor for morbidity and mortality in the Third World.

BASICS OF IMMUNIZATION

Vaccination and immunization, though interchangeable in practice, are not exactly synonymous. *Vaccination* is the process of inoculating the antigen (vaccine) into the body, regardless of its seroconversion. *Immunization* is the process of inducing immune response, humoral or cell-mediated, in the body.

Primary immune response occurs when an antigen is introduced for the first time and the immune system responds primarily after a lag phase of upto 10 days. Besides lag phase, primary response is short-lived, predominantly IgM type and has low titer. On reintroduction of the same antigen, there is no lag phase. The immune system responds by producing antibodies immediately. This is called *secondary*

immune response. Secondary response is immediate, long-lasting, has very high titer.

Immune response may be: 1. T cell-dependent, and 2. B cell response.

T cell-dependent response involves both T cell and B cell. It is prompt, IgG type, longer-lasting and with high titer and shows booster effect with repeated exposures. It also reduces carrier state because of production of IgA. After 6 weeks of age, this response is evident.

T-cell independent response is only B cell mediated. It is mainly IgM type, short-lived, shows revaccination rather than booster effect and does not reduce carrier state. It occurs after 2 year of age only.

Conjugation is a technique whereby T-cell independent antigen (polysaccharide) can be made into T-cell dependent. The conjugated vaccine can be given under 2 years of age. Examples: Conjugated Hib, pneumococcal, vi typhoid, meningococcal vaccines.

CATEGORIES OF VACCINES

Vaccines may be live attenuated (LAV) or killed (inactivated). In genetically engineered attenuation, virulence determining gene is deleted e.g. Typhoid and cholera vaccines. LAVs are capable of replicating within the body and stimulating immune response. As a rule, usually a single dose should be good enough for long-term immunity. They can, though rarely, become virulent and cause disease per se. These are contraindicated in immunocompromised states.

Killed vaccines do not multiply in the body and need to be given in multiple primary and booster doses.

Table 10.1 lists various vaccines that are currently recommended.

Table 10.1: Classification of vaccines**Bacterial***Live* : BCG, typhoid*Killed* : Cholera, pertussis, tetanus, diphtheria, meningococcal, *H. influenzae* type B, pneumococcal**Viral***Live* : Polio (Sabin), measles, mumps, rubella, yellow fever*Killed* : Polio (Salk), rabies, hepatitis B, influenza, Japanese encephalitis**Box 10.1:** Recommendations on storage of vaccines in the refrigerator

Compartments	Vaccines
Freezing compartment	OPV
Main compartment	
Top	BCG, measles, MMR, mumps
Middle	DPT, DT, TT Hep A, Hep B
Lower	Diluent

COLD CHAIN

The “Cold chain” is a system of storing and transporting vaccines at low temperature from the manufacturer to the actual vaccination location, so that their potency and efficacy are preserved. A failure of cold chain may result in inadequate or negligible protection against the disease despite vaccination. The reports of occurrence of vaccination preventable disease in populations considered to be adequately immunized through vaccination appear to be related to cold chain failure.

Three vital elements in successful cold chain are cold chain equipment, transportation and motivated and trained manpower for maintaining the link.

The cold chain equipment consists of:

Cold box This can transport large quantities of vaccines by vehicle to outreach sites, preserving the vaccine for up to one week without any power supply at all.

Vaccine carrier This is designed to transport small quantities of vaccine by a vehicle, bicycle or on foot to outreach sites, preserving the vaccine for up to 3 days.

Flask This is only a substitute for carrier but should not be much encouraged.

Ice-Packs These are employed for use in box, carrier or flask.

Box 10.1 gives guidelines regarding storage of vaccines for prolonged life in a refrigerator. Note that storing OPV in deep freezer with a temperature of minus 20°C enhances the life of the vaccine from 3 months to 1 year.

SOME ADDITIONAL IMMUNIZATION-RELATED MATTERS**Vaccine Vial Monitoring (VVM)**

If the small square within the circle matches the circle or becomes darker, the vaccine needs to be discarded even if its expiry date is still away.

Route of Administration

- Sabin Polio vaccine (OPV) and typhoid Ty21 are the only vaccines given orally as of now.
- Live vaccines (measles, MMR) are best given SC, in thigh of infants and deltoid area of older children.
- BCG is given ID, usually over volar surface of forearm.
- Most vaccines (typhoid, DPT, HB, HA, Hib) are given IM, in infants over anterolateral aspect of thigh (in infants) and deltoid (in later age). It is advisable to avoid the gluteal area because of risk of injury to sciatic nerve as also reduced immunogenicity of certain vaccines (hepatitis B and antirabies).

Safe Injection Practices

These should include

- Separate syringe and needle for each injection
- Separate anatomical sites and separate limb for multiple injections
- Observation of the child for at least 15 minutes after administration of an injection.

RECOMMENDED IMMUNIZATION SCHEDULE

The *National immunization schedule* is given in Table 10.2 and the IAP Advisory Committee recommended schedule in Table 10.3.

BCG VACCINATION

BCG (bacillus of Calmette* and Guerin*) vaccine is an attenuated live vaccine obtained from the bovine strain of tubercle bacilli. It produces controlled primary tuberculous infection. Thus, an immunity to tuberculosis without exposure to risks of natural infection is accomplished. There is some evidence that BCG also protects against leprosy and leukemia.

* Two scientists of the Pasteur Institute, Paris, who developed this vaccine in early part of this century.

Table 10.2: National immunization schedule

Beneficiaries	Age	Vaccine	No. of doses	Route of administration
Infants	6 weeks to 9 months	DPT	3	Intramuscular
	6 weeks to 9 months	Polio	3	Oral
	Birth to 3 months	BCG	1	Intradermal
	9 to 12 months	Measles	1	Subcutaneous
Children	18 to 24 months	DPT	1*	Intramuscular
	18 to 24 months	Polio	1*	Oral
	5 to 6 years	DT	1**	Intramuscular
	5 to 6 years	Typhoid	2	Subcutaneous
	10 years	TT	1**	Intramuscular
	10 years	Typhoid	1**	Subcutaneous
	16 years	TT	1**	Intramuscular
	16 years	Typhoid	1**	Subcutaneous
Pregnant women	16 to 36 weeks	TT	1**	Intramuscular

*Booster doses

**2doses, if not vaccinated previously

Note: • Interval between two doses should not be less than one month

• Minor coughs, colds and mild fever are not a contraindication to vaccination

Table 10.3: Indian Academy of Pediatrics (IAP) recommendations on immunization schedule

Vaccine	Primary	Booster
BCG	Birth to 2 weeks	
OPV	Birth	
	6 weeks	15 to 18 months
	10 weeks	
	14 weeks	
Hepatitis B	9 months	
	Birth	10 years
	6 weeks	
DPT	6 to 9 months	
	6 weeks	15 to 18 months
	10 weeks	5 years
	14 weeks	
Measles	9 months plus	
MMR	15 to 18 months	
Tetanus toxoid		10 years
		16 years
<i>Optional Vaccines</i>		
<i>Typhoid</i>		
Whole-cell killed (TA) vaccine: 2 doses 6 to 9 months apart, booster every 3 to 5 year		
Vi Polysaccharide Vaccine: A dose every 3 years starting at or after 2 years		
Oral vaccine: 3 doses, each on day 1, 3 and 5, at/or after 6 years, booster every 3 year		
<i>H. influenzae type B</i> : 3 doses, 1 to 2 months apart, starting at 2 months, booster at 15 to 18 months.		

The current practice is to employ heat stable, freeze-dried powder (to be reconstituted using normal saline) which should preferably be stored at 2 to 10°C. In India it is produced by the BCG laboratory, Guindy, Chennai. As recommended by the WHO, it is the Danish 1331 strain of the bacilli, available in multidose vials. More recently, isonex-resistant BCG vaccine has also become available. Once the BCG vial is opened, it has got to be used within 4 hours. Leftover vaccine must be discarded.

At What Age(s) to Vaccinate?

In India, as in other developing countries, direct primary vaccination against tuberculosis is recommended at birth or earliest contact after birth.

Site

The standard site is the middle of deltoid (just above its insertion) over the left upper arm. When BCG and triple vaccinations are being simultaneously given, it is advisable to choose different arms.

Method

0.1 ml (0.05 ml in neonates) of BCG is injected intradermally with a special tuberculin syringe. For mass immunization the jet injector is of distinct value.

1 Normal Reactions Following Vaccination (Immunogenicity)

A papule appears in 2 to 3 weeks after vaccination. By about the fourth week, it grows in size to 4-8 mm. Then it either subsides or sheds into a shallow ulcer covered with a crust. This ulcer heals spontaneously in nearly 8 to 12 weeks time, leaving behind a tiny scar. After several years, this scar may fade and even entirely disappear.

There is, however, one noteworthy exception. If a tuberculin positive reactor is vaccinated, there is likely to be an accelerated response (Koch's phenomenon) with a papule or red angry ulcer at the injection site after only 1 to 3 days and lasting about 3 weeks. This is almost harmless and does not disfavor the present practice of direct BCG without prior tuberculin (Mantoux) test.

It seems to be appropriate to do Mantoux test 2 to 3 months after BCG administration. In case it turns out to be negative, BCG should be repeated.

Contraindication

- Skin ailments like eczema and burns
- Immunodeficiency (hypogammaglobinemia, symptomatic HIV, deficient cell-mediated immunity)
- Immunosuppressant (e.g steroid) therapy
- Within 4-6 weeks of immunosuppressive illnesses like measles
- Pregnancy

Adverse Reactions (Complications) and their Management

These are uncommon and rather mild:

- *Accelerated reaction* in tuberculous sensitive individuals
- *Deep ulceration* of the vaccination site together with superadded bacterial infection
- *Simple Lymphadenitis* involving axillary lymph gland (less than 1 cm in diameter) without any progression or signs of suppuration should be regarded as a normal, though somewhat exaggerated, response to BCG and a part of the induced "primary complex". It should be left as such.
- *Suppurative Lymphadeniti*. Axillary and/ or cervical lymph glands may attain considerable size (Fig. 10. 1) and, at times, develop suppuration and abscess



Fig. 10.1: BCGosis. Note the significant axillary lymphadenitis (persistent and progressive) following routine BCG vaccination

formation. This is termed *BCGosis* or simply *BCG adenitis*. Pyogenic antibiotics may be given in such cases. Many surgeons, however, recommend excision of the glandular swelling. There is a good deal of consensus that every child with BCGosis should have at least X-ray of the chest. If it shows evidence of primary complex, a full antituberculous course is justified. If X-ray chest is clear, the child should receive only isonex, 5 to 10 mg/kg/day.

- v. *Keloid formation* over the site of vaccination. Very rarely, suppurative osteomyelitis and disseminated tuberculosis (in immunocompromised states may occur. **Protective Efficacy** BCG offers around 80% protection against serious forms of tuberculosis (miliary and CNS tuberculosis), about 50% protection against pulmonary tuberculosis and no protection against simple tuberculous infection.

POLIO VACCINATION (Fig. 10.2)

Oral polio vaccine (OPV), *Sabin vaccine*, is a live but attenuated virus. Storage is best done at 2 to 10°C. Since it is cheaper, easy to administer, helps to prevent establishment and spread of wild pathogenic poliovirus in the community, and can be used in blanketing operations to check the spread of an incipient outbreak, it is being used by a large majority of the countries the world over. This has earned it the designation "community vaccine".

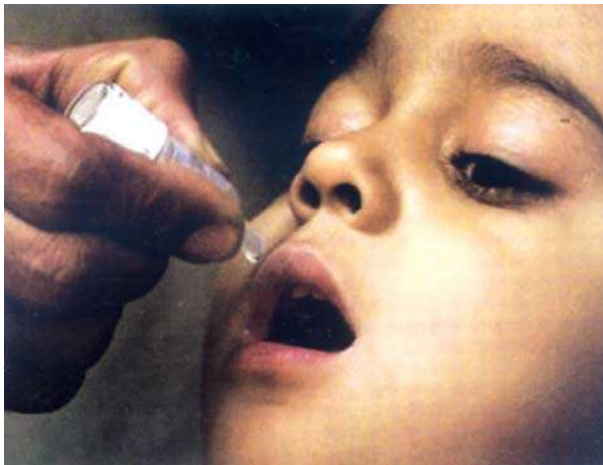

Fig. 10.2: Oral polio vaccine program

The killed (inactivated) injectable poliovaccine (IPV), the so-called *Salk vaccine**, is required to be administered parenterally. It does not interfere with the spread of natural virus in the community though it does produce individual immunity to polio. The differences between the Salk and Sabin vaccines are highlighted in Table 10.4.

Table 10.4: Salk vs Sabin vaccine	
Salk Vaccine	Sabin Vaccine
i. Killed and formalised	Live attenuated
ii. Expensive	Relatively cheap
iii. Administered parenterally (intramuscular or subcutaneous injection)	Administered orally, hence easy and less cumbersome for patient as well as the worker
iv. Immunity shortlived	Quite prolonged
v. Does not produce local intestinal immunity since antibodies are in the circulation	Produces both local as well as circulation (general) immunity
vi. Reinfection with wild poliovirus possible though it does prevent paralysis.	Reinfection with wild poliovirus as well as paralysis are prevented
vii. Offers no protection to the nonvaccinated people	Through cross infection others are also protected
viii. Of no significant value in controlling epidemics of poliomyelitis	Of definite value

* After the name of Dr Jonas Salk who was awarded the "1976 Nehru Award for International Understanding" at a special ceremony held at the All India Institute of Medical Sciences, New Delhi

Both vaccines, usually supplied as a trivalent antigen providing three strains of poliovirus (Lansing, Leon and Brunhilde), are highly effective. Monovalent OPV, providing only one strain, is also available (mOPV).

The following details pertain to the trivalent Sabin vaccine. Availability

At What Age(s) to Vaccinate?

As per current recommendation of the Indian Academy of Pediatrics (see Table 10.3), primary doses are given at birth (zero dose), then at 6 weeks, 10 weeks, and 14 weeks. A booster dose is given in second year (15-18 months) and yet another in the fifth year. A total of 6 doses are, therefore, recommended to ensure reasonably high personal protection from polio-myelitis.

OPV given in pulse polio campaigns should be considered over and above these doses. OPV requires to be essentially administered even if the child has suffered from the disease.

In grown-up children (beyond 8 years of age) polio vaccine may not be given. This is because the older children are more or less immune to natural infection with poliovirus.

Administration

OPV is administered as two drops directly into the mouth. This should be followed with the feeding of some water to ensure absolute ingestion of the vaccine. It is now convincingly shown that antibodies in breast milk against poliomyelitis do not interfere with the take of the vaccine and the consequent immune response. Breastfeeding need not be skipped before and after OPV administration.

Pulse polio means simultaneous mass immunization of all infants and children under 5 years at a particular date i.e. National Immunization Day (NID) during winter (usually Dec-Jan) regardless of their immunization status. It is over and above the routine doses of OPV.

Mopping-up means administration of OPV, in two doses 4-6 week apart, to all children under 5 years regardless of their immunization status in areas at high-risk for transmission of wild polio virus. For this purpose, house-to-house visits are made in the concerned area.

Ring immunization means administration of OPV, in two doses 4-6 week apart, to all children under 5 years within an area of 5 km within 48 hours of finding a case of polio. For “pulse immunization”, see Chapter 12.

How OPV Behaves in the Body?

On entry in the gut, strains of OPV multiply. As a result there is production of local as well as systemic immunity. The vaccine also leads to production of antibodies like IgG, IgM and IgA. The last-named is said to contribute to the local immunity whereas the remaining two limit spread of the poliovirus to the CNS and protect against paralysis.

Contraindications

1. It should be avoided in children suffering from severe diarrhea and an acute illness.
2. Leukemia and other malignancies
3. HIV (immunocompromised state, symptomatic)

Adverse Reactions

Though OPV is exceedingly safe, it may cause.

- Mild diarrhea in case of overdose
- Vaccine-associated paralytic poliomyelitis (VAPP) due to vaccine virus per se very rare (one in 2.5 millions).
- Monitoring

If the inner square of the vial matches the outer square or becomes darker, the vaccine should be discarded.

ENHANCED INACTIVATED POLIO VACCINE (EIPV) (SALK VACCINE)

Now that eradication of polio is round the corner, over and above the OPV, the enhanced IPV (available as *imovax polio*) may be introduced in the national immunization schedule. In addition to routine immunization against polio. It is especially indicated in immunocompromised children and for boosting the eradication endeavors.

Dosage Schedule

- 0.5 ml (SC) in lateral thigh in infants and deltoid in grown-up children at
 - 8 and 16 weeks, or
 - 6,10 and 14 weeks
- Booster is required at 15 months.

Side-effects

No significant side-effects.

Storage

2-8 degree C.

Availability

As such and in combination with other vaccines.

DPT VACCINATION

DPT (*triple*) vaccine offers combined prophylaxis against diphtheria, pertussis and tetanus. The pertussis toxoid offers administrative convenience as well as potentiates the effect of diphtheria toxoid.

Both whole cell and acellular vaccines are available. The latter is safer and also available as reduced antigen Tdap booster vaccine for use in older children and adolescents in whom immunity against DPT may have waned.

The vaccine is best stored at a temperature of 2 to 10° C.

At What Age(s) Vaccinate?

Primary vaccination consists in giving three doses at the age of 6, 10 and 14 weeks followed by booster at 15-18 months and 5 years.

Administrative of OPV and triple vaccine at one sitting is an accepted procedure now and should be encouraged.

Administration

A dose of 0.25 to 0.5 ml of the triple vaccine is given deep intramuscularly over the lateral thigh or the deltoid.

Contraindications

The only contraindications to DPT immunization are

- Severe reaction to previous DPT injection
- Progressive neurologic diseases.

Adverse Reactions

- Fever and febrile convulsions
- Local painful swelling, even sterile injection abscess
- Occasionally 1 to 3 hours after injection, collapse (pallor, sweating, slow pulse) from which the child invariably recovers in an hour or two
- Allergic skin rash
- Pseudotumor cerebri

- Encephalitis
- Provocation or activation of polio during an epidemic of the disease.

TYPHOID VACCINATION

Currently recommended vaccines are:

1. Oral typhoid vaccine: oral *S. typhi* (Typhoral), and
2. Injectable Vi capsular polysaccharide typhoid vaccine (Typhim Vi, Vac Typh, Typhivax, Typho-Vi, Tyvax-Vi)
3. *Classical*: Whole-cell killed TA vaccine as it also includes *S. paratyphi* A.

Oral typhoid vaccine It contains Ty 21 live attenuated mutant strains of *S. typhosa*. The dose is one capsule on day 1, 3 and 5 one hour before a meal, given every 3 years. The vaccine is well tolerated; rarely slight gastrointestinal upset and rash may occur. It confers a protection varying from 67 to 95%. Storage between 2 to 8°C and protection from light is vital for its stability. For quite a few years, it is not available in India.

Contraindications include immunodeficiency, immunosuppressant drugs, antimetotics, certain antibiotics and sulfas active against salmonella, acute febrile illness, GIT infection, and pregnancy.

Polysaccharide Vi typhoid vaccine It contains purified Vi capsular polysaccharide (ViCPS). The dose is one injection (0.5 ml containing 25 meg of ViCP9) given SC or IM as a single dose every 3 years. It confers a protection of 75 to 100%. Only mild local pain and fever may rarely occur as side-effects. Contraindications include hypersensitivity and pregnancy.

Ideally, for maximal protection, these vaccines are recommended to be administered after 5 to 6 years of age. Nevertheless, in view of increasing occurrence of typhoid fever under 5 years of age, especially in the Indian subcontinent, starting typhoid immunization at 18-24 months with injectable vaccine in endemic areas is justified.

Whole cell killed TA vaccine is quite cheap and manufactured locally in India (though at present its production is suspended). It is given in two doses 0.25 - 0.5 ml each (SC) at an interval of 4-6 weeks, starting at 6 months of age or later. However, it is likely to cause side-effects such as local pain and induration, pyrexia and body pains over the next 2-3 days. Reactogenicity is less in monovalent (containing endotoxin of *S. typhi* only) vaccine, acetone killed and dried preparation (AKD vaccine). Revaccination every 3 years is needed.

The following improved new typhoid vaccines which can be given to the infants too are under clinical trial:

1. Genetically engineered strains of *S. typhi* as single dose live oral vaccines having higher immunogenicity over Ty 21 a.
2. Parenteral Vi-conjugate vaccine that stimulates higher titers of Vi antibodies than unconjugated Vi polysaccharide and elicits immunologic memory.

Whole cell (conjugated) typhoid vaccine is safe and can be given to even infants.

CHOLERA VACCINATION

The currently available cholera vaccine, required to be given by the subcutaneous injection, has a protective value of around 50% for period of 3 to 6 months.

The dose is 0.3 ml and 0.2 ml for children above and below 2 years, respectively. Two doses are given at an interval of 4 to 6 weeks.

Reactions include local pain, erythema and edema, occasionally abscess formation may occur. Fever is unusual.

During the course of an epidemic, the vaccine is of no practical value. In fact, it may contribute to the occurrence of outbreaks of hepatitis B and poliomyelitis.

Research for developing an improved and more potent oral cholera vaccine is in progress. The existing vaccine is a saline suspension of about 12 thousand millions cholera vibrios/ml, killed and preserved in 0.5% phenol.

MEASLES VACCINATION

A live, attenuated measles vaccine (*Schwartz strain from chick embryo tissue culture, Edmonston strain from human diploid cells*), has a definite protective value of as high a magnitude as 95 to 100%. A single dose produces antibodies for an indefinitely prolonged period. Boosters are usually not needed.

An aerosol measles vaccine has yielded gratifying results in Mexico. Besides convenience in administration, it may well overcome other limitations of the injection.

At What Age(s) to Vaccinate?

The national recommendation for measles vaccine is at 9 to 12 months of age with revaccination at 15-18

months in the form of MMR vaccine. In high-risk situations it may be given earlier but, in that event, it must be repeated after a gap of 6 months.

Dosage

0.5-1.0 ml (SC, ID, IM).

Contraindications

- Acute illness
- Immunosuppressive therapy (steroids, anti-metabolites, alkylating agents) over prolonged period
- History of convulsions in the child or the family
- Leukemia
- Active tuberculosis
- Immune deficiency states (hypogammaglobulinemia, severe HIV)
- Recent gammaglobulin administration.
- Allergy/eczema

Adverse Reactions/Complications

Practically no remarkable complications occur if the vaccine is administered carefully and precautions taken in the wake of the aforesaid relative contraindications.

- Mild measles-like illness with fever and rash 5-10 days after immunization
- Febrile reactions for a day or two from fifth to twelfth post-vaccination day in a proportion of the cases.
- Even convulsions may occur.
- Slight gastrointestinal upset and
- Rhinopharyngitis
- Toxic shock syndrome

Precaution

Reconstituted vaccine must be employed the same day and the leftover discarded.

MUMPS VACCINATION

Again, like measles vaccine, it is a live, attenuated virus obtained from the *Jeryl-Linn strain* (named after the child from whom it was isolated). Its protective value is of the order of 95% and it probably gives long immunity. It is supplied as lyophilized powder which on reconstitution should be used promptly. The dose is 317 TCID (tissue culture infective dose) which should be administered subcutaneously or by jet gun. Mumps vaccine is very safe.

RUBELLA VACCINATION

Rubella vaccine too is a live, attenuated vaccine. Rubella vaccination decidedly protects against the occurrence of so-called *congenital rubella syndrome* in the offspring.

Indication

- Immunization of girls from 1 year to puberty
- Susceptible women of child-bearing age (with hemagglutination test negative) provided they are not already pregnant and conception is unlikely in the subsequent 2 months

Dose

0.5 ml (SC) upper arm as a single dose

Contraindication

- Febrile respiratory illness
- Pregnancy

Adverse Reaction

Local pain, erythema and induration at injection site.

MMR VACCINE

Indication

MMR, a live attenuated vaccine (*Priorix*), is recommended as a backup dose for protection against measles in the second year of life (at around 15 months of age, at least 3 months following primary measles vaccination in the first year).

Dose

0.5 ml (SC) at 15-18 months.

Contraindications

- Immunodeficiency
- Recent administration of immunoglobulins
- Known anaphylaxis due to egg allergy.

Adverse Reactions

- Fever and febrile seizures
- Lymphadenitis
- Parotitis

The suspicion of a causal relationship of MMR vaccine with autism is unfounded.

H. INFLUENZAE TYPE B VACCINE

This vaccine (Hiberix, HIBest, ACT-HIB, Hib TITER) aims at protecting against *H. influenzae* type B infection (pneumonia, epiglottitis, meningitis) which is believed to cause significant morbidity and mortality in infants and toddlers.

At least four conjugate polysaccharide HIB vaccines are available, namely (1) diphtheria toxoid conjugated vaccine (PRP-D), (2) oligosaccharide conjugated vaccine (HbOC), (3) meningococcal OMP conjugate vaccine, and (4) tetanus toxoid conjugated vaccine (HiB-TT, PRP-T).

Indications

IAP now recommends it as a routine vaccine for protection against H influenzae type B, usually simultaneously with DPT.

High-risk situations where it must be given even in older children include:

- Immunodeficiency disorder
- Asplenemia.
- Sickle-cell anemia
- Lymphoblastic leukemia
- Hodgkin lymphoma.

Dose

10 meg (0.5 ml) IM. The vaccine is administered in 3 doses, at 6, 10 and 14 weeks. Booster is recommended at 15 -18 months. If the child first reports between 6 and 12 months, only 2 primary injections and >1 year, only one injection is recommended.

Contraindication

Hypersensitivity to its components.

Adverse Reactions

HIB vaccine is very safe, usually causing no local or systemic reaction. It does not increase the risk of IDDM due to formation of islet-cell antibodies as suggested earlier.

HEPATITIS B VACCINE

Hepatitis B vaccine consists of hepatitis surface antigen related protein- a highly purified suspension of inactivated, alum-adsorbed HBsAg particles. Now only DNA recombinant, i.e. genetically engineered (Engerix- B, Shanvac-B, HB Vac, Enivac HB, Revac-B)

vaccine is in vogue worldwide. The World Health Organization (WHO) recommends incorporation of the hepatitis B vaccine as the seventh vaccine in the routine immunization schedule in the South-East Asia and the Pacific.

Indications

IAP now recommends it as a routine vaccine. High-risk situation in which it must be given include

- recipients of multiple blood transfusions
- household sexual contacts of carriers of HBV
- users of parenteral drugs such as heroin
- homosexually active males,
- hemodialysis subjects
- immigrants from areas of high HBV endemicity
- babies born to mothers with HBsAg positive blood.

Dose

The vaccine,, is administered intramuscularly in a dose of 0.5 ml (10 mcg) and 1 ml (20 mcg) for children below and above 10 years, respectively. IAP recommends it at birth, 6 weeks and 14 weeks or 6, 10 and 14 weeks. Else, it may be given in two doses 1 month apart followed by a booster 6 months later.

Postexposure prophylaxis According to IAP recommendation, if the pregnant woman is a known carrier of HB virus, her neonate should be given HB immune globulin (HBIG) within 12 hours of birth and also one dose of HB vaccine with a separate syringe and needle over a different site on the body. If HB Ig is not available, HB vaccine must be given. If there has been a delay of over 12 hours, HBIG need not be given. However, HB vaccine has got to be started. The second dose of the vaccine is given 4 weeks later and the third 5 weeks (4-6 weeks) later. It may well be convenient to give the third dose at the same time as measles vaccine, at or after 9 months.

In case the mother is known not to be a carrier of HB, there is no need to give HB vaccine immediately after birth. It can conveniently be given at the first visit for other vaccines, such as 6 weeks when a dose of DPT or OPV is due. The second dose of HB vaccine may be given 4 weeks later and the third at the time of measles vaccine.

Contraindications

Hypersensitivity to its components.

Adverse Reactions

- Transient soreness, erythema and induration at injection site
- Low grade fever.

There is no evidence that it causes development or flare-up of demyelinating diseases such as multiple sclerosis (suspected in France a few years ago).

Storage

2-8 degree C.

HEPATITIS A VACCINE

IAP considers it as an “additional” vaccine.

Indication

Active immunization against hepatitis A, especially in children who are less likely to have developed natural immunity because of a sophisticated lifestyle.

Dose

Killed vaccine (Havrix): It is given intramuscularly as a single dose, 720 units from 1 year to (and including) 18 years, and 1440 units from 19 years onward. A booster is recommended 6-12 months after the primary dose. Live attenuated (Biovac): Single dose IM after first year

Side-effects

- Transient painful injection site,
- Nausea, vomiting, headache, malaise, anorexia
- Pyrexia

Storage

2-8 degree C.

VARICELLA VIRUS (CHICKENPOX) VACCINE

A live attenuated varicella virus vaccine (*Varilrix*, *Okavax*) provides a high degree of protection against chickenpox. It is quite expensive.

Indication

Active immunization against chickenpox after 1 year of age.

Dose

Varilrix is administered as a single dose (0.5 ml SC) 1-12 years of age. Thereafter, i.e. 13 years and later, it requires to be given in two doses 6-10 weeks apart. The other varicella virus vaccine, *Okavax*, is recommended as a single dose for all ages.

Contraindications

- Acute severe febrile illness
- HIV subjects with lymphopenia (TLC < 1200mm³)
- Neomycin hypersensitivity.

Adverse Reactions

Both the vaccines are quite safe and well tolerated. Locally, a mild transient reaction may occur. Rarely, rash may be encountered.

Protection

In children exposed to chickenpox case, efficacy is 80% in protecting against chickenpox provided that it is administered within 3 days of exposure to a case of chickenpox.

COMBINATION VACCINES

These are vaccines which contain several antigens in a single vaccine for protection against quite a few infectious diseases. Their benefits include

- Reduction in number of pricks
- Reduction in number of visits to the health centre
- Reduction in cost of administering and stocking vaccines
- Reduction in pressure on cold chain
- Increase in compliance
- Facilitation in introduction of new vaccines in the immunization schedule

DTP and MMR are examples of combination vaccines available since 1945 and 1971, respectively. It is around DTP that various antigens tetravalent and pentavalent vaccines are built up.

1. DTPa -IPV: It is in use since 1990 in countries where polio stands eradicated and inactivated (killed) polio vaccine (IPV) is being employed. In India, we are still using OPV. It is, therefore, not yet available.
2. DTPa -Hep B
3. DTP_a+HepB + Hib
4. HepB-Hep A

New combination vaccines in pipeline include:

- MMR-Varicella
- DTP_a-IPV-Hib-HepB.

POLYVALENT PNEUMOCOCCAL VACCINE

The polyvalent pneumococcal vaccine, (*Pneumovax*, *Pnu-Immuri*) claims to protect against most of the commonly encountered pneumococcal infections like pneumonia, bacteremia, meningitis and otitis media.

Indications

- High-risk patients of chronic disease, e.g. cardiac, pulmonary, renal or metabolic disease
- Patients whose spleens have been removed.

Though children under 2 years are at high-risk of suffering from *Streptococcus pneumoniae* infection, the currently available vaccine is not effective in this age group because of poor immunologic response. It needs modification to be effective in them.

Dose

Dose is 0.5 ml (IM, SC). Revaccination after 3-5 years until age of 10 years.

Adverse reactions

These include local painful swelling, pyrexia, Guillain-Barre syndrome, relapse of disease in ITP and anaphylaxis.

Special Remarks

Against the routinely-used 21-valent unconjugated pneumococcal vaccine, recently a 7-valent conjugated vaccine has become available in Western countries. It is relatively safer, more effective and can be employed even in infants as young as 2 months in 3 doses 2 months apart with a booster at 12-15 months. In United States, it has become an essential part of immunization schedule to prevent invasive pneumococcal disease, reduce antibiotic resistance among pneumococcal strains and reduce incidence of pneumonia in children.

INFLUENZA VACCINE

Influenza (flu) vaccine is now available in India under the trade names *Vaxigrip* (Sanofi-Pasteur) and *Fluarix* (GSK).

- This vaccine (A and B) prepared from currently prevalent strains is an inactivated vaccine, giving a reasonable degree of protection for a short time only
- Chronic aspirin therapy
- HIV infection
- Pediatric subjects, doctors and nurses, etc. who become grossly overworked during influenza epidemics.

Dose

6 months - 6 years: Two doses of 0.25 ml (SC, IM) at 4-6 week interval

6 - 9 years: 0.5 ml (SC, IM) at 4-6 week interval

> 9 years: 0.5 ml (SC, IM) as a single dose

Revaccination is needed every year.

Protection

Only 6-12 months.

Adverse Reactions

- Local pain, induration and erythema
- Anaphylaxis
- Allergic reactions to components of vaccine.

Contraindications

Hypersensitivity to its components.

Storage

2-8°C.

MENINGOCOCCAL VACCINE

Meningococcal vaccine A+C, now available in India contains 50 µg each of purified lyophilized polysaccharide of *Neisseria meningitidis* group A and C. Effectiveness of the vaccine is purely group specific.

Sero group A is responsible for epidemics of meningococcal infections in India. The available vaccine, therefore, is suitable for use in this country. Protection efficacy is 90%.

Indications

- All residents of an epidemic area
- Close population groups, say schools
- All contacts of an index case, especially family members (in addition to the drug prophylaxis).

- High-risk groups: Asplenemia and immune (complement) deficiency.

Dose

Under 2 years: 0.5 ml (deep SC), preferably in deep infraspinal fossa, in a single dose. 2-4 years: 2 injections at 1 year gap Over 4 years: 2 injections at 5-year gap.

Side-effects

Local redness and edema, pyrexia.

JAPANESE ENCEPHALITIS (JE) VACCINE

Indication

Single most important control measure against Japanese encephalitis.

Dose

Formaline inactivated mouse drain or hamster kidney vaccine: Two doses, 1 ml each (0.5 ml for under 3 years age) are administered at an interval of 7 to 14 days subcutaneously. After 6-12 months, a third dose is given. Every 3 to 4 years, a booster dose is needed.

Live-attenuated vaccine: 2 doses, 4 weeks apart (SC).

Contraindication

JE vaccine is contraindicated in high fever, diabetes mellitus, liver and heart disease and immunodeficiency

Adverse Reactions

JE vaccine is quite safe.

VACCINATION AGAINST RABIES

The old, conventional vaccine (Semple vaccine), an inactivated (by treatment with an agent called *beta-propranolactone*) suspension of sheep brain, carries high risk of neuroplogic reactions (meningoencephalitis, ascending paralysis, polyneuritis). There is no justification for using it in the wake of availability of two potent and safe vaccines:

1. FLSC (Human diploid cells) vaccine is a sure, safe and painless preventive measure against hydrophobia. It is a lympholized, stabilized suspension of rabies virus completely inactivated by B-prolactone. It is prepared on the human deployed cells.

This vaccine is given as 1 ml subcutaneous injections immediately after exposure, on 3rd day, 7th day, 14th day, 30th day and 90th day. In case antirabies treatment is begun immediately with cleansing of the bitten area with soap and water and administration of antirabies serum (human or animal) sixth injection may well be missed.

HDC rabies vaccine, unlike the conventional antirabies vaccine, is very safe. In 1%, redness and induration at the injection site may occur. Slight pyrexia and asthenia occur with the same frequency.

2. PCEC (*purified chick embryo cell*) is next to HDC in potency. It is now being locally manufactured in India at Ankleshwar, Gujarat, and is available under the proprietary name *Rabipur* (Hoechst). Its administration is in the same schedule as for HDC vaccine.

With the availability of HDC and PCEC vaccines, there is hardly any justification for using the old antirabic vaccine (NTV). Unfortunately, since these vaccines cost exorbitantly, it is only NTV that continues to be available in most antirabic centers in India.

Seroprophylaxis with rabies human immunoglobulin (RHIG), 20 IU/kg, or rabies animal immunoserum, 40 IU/kg, as a single injection is recommended in all cases with severe exposure. It should be given as soon as possible preferably immediately after the bite. After 7 to 8 days of bite, it is unlikely to be of any benefit. Half of the dose is infiltrated in the tissues around the bite and the remaining half injected intramuscularly.

FURTHER READING

Article/Chapter

1. Levine MM: Use of vaccines for prevention of typhoid fever. *Indian Pediatr* 2003;40:1029.

Books/Monographs

1. Indian Academy of Pediatrics. *Safe Injection Practices*. IAP Task Force Recommendations Mumbai: IAP 2005.
2. Indian Academy of Pediatrics. *IAP Guidebook on Immunization*. Mumbai: IAP 2001.
3. Parthasarthy A, Lokeshwar MR, Shah MR. *Partha's Immunization Digest*. New Delhi: Jaypee 2005.

CHAPTER



11

Pediatric Nutritional Requirements

Suraj Gupte, Shashi Vani

INTRODUCTION

Adequate nutrition is of paramount importance during childhood, especially in the first 3 years of life, when growth is most rapid and the child is, by and large, totally dependent on his caretaker(s), usually the parents. Since an important factor responsible for adequate growth is balanced nutrition, erroneous nutrition leads to inadequate growth in addition to undernutrition and poor weight gain. Naturally, a basic knowledge of nutritional requirements at various ages as also sources of such vital nutrients as vitamin A and micronutrients as iron and zinc is mandatory. The term, *energy requirement*, denotes the amount of dietary energy required to balance energy expended and deposited in new tissues (growth). Table 11.1 gives the break-up of energy expenditure.

Table 11.1: Break-up of energy expenditure

Growth	12%
Physical activity	25%
Basal metabolism	50%
Fecal loss	8%

In order to meet the growth needs in first 3 years and during adolescence, a higher energy dense diet (less complex carbohydrates and larger quantity of fat) is needed.

Water, proteins, carbohydrates, fats, vitamins and minerals are the chief constituents of food. These six factors form the human body in the following way: water 63%, proteins 17%, fats 12%, carbohydrates 1% vitamins and minerals 7%.

WATER

It is second only to oxygen as a “must” for survival. Compared to adults, infants require much larger amount of water per unit of body weight. Its requirements at different ages are given in Table 11.2.

Table 11.2: Daily requirement for water

Age range	Water requirement (ml/kg)
First 3 days	80 to 100
3 to 10 days	125 to 150
15 days to 3 months	140 to 160
3 to 12 months	150
1 to 3 years	125
4 to 6 years	100
7 to 9 years	75
10 to 12 years (and thereafter)	50

ENERGY

Calorie or energy requirement varies from age to age as is shown in Tables 11.3 and 11.4. On an average, 50% of calories should come from carbohydrates, 35% from fats and 15% from protein.

It is worth remembering that daily requirement is 100 to 120 kcalories per kg for the first year of life.

Table 11.3: Daily calorie requirement of infants

Age range (months)	Requirement calorie per kg
0 to 3 months	120
3 to 6 months	115
6 to 9 months	110
9 to 12 months	105

Table 11.4: Daily requirement for calories

Age range (years)	Requirement k calorie per kg
Under 1 (average)	110
1 to 3	100
4 to 6	90
7 to 9	80
10 to 12	70
13 to 15	60
16 to 19	50
Adult	40

During the following period, it decreases by around 10 kcalories per kg for each succeeding 3-year duration.

Table 11.5 presents the total daily calorie requirement during the first year of life. It is apparent that an infant of 1 year of age needs about 1,000 k calories. A rough rule is to add 100 calories per each year of age upto a maximum of 1,500 kcalories. About adolescence; when the growth spurt occurs, calorie needs are much higher. According to this rule a child of 5 years of age needs $1,000 + 400 = 1,400$ k calories.

According to Holiday and Seger formula, calorie requirement is as follow:

- up to 10 kg : 100 kcal/kg
- 10 to 20 kg : 1000 + 50 kcal for each kg > 10 kg
- > 20 kg : 1500 + 20 kcal for each kg > 20 kg

Break-up of energy requirement is as follows:

- Maintenance of basal metabolism 50%
- Specific dynamic action 5%
- Growth 12%
- Physical activity 25%
- Losses in stools, etc. 8%

Tables 11.3 to 11.5 give approximate requirements for calories.

Table 11.5: Absolute daily requirement for calories during first year

Age (months)	Calorie requirement
1	500
2	600
4	700
5	800
9	900
10	1,000

PROTEINS

Proteins of animal origin are termed “biologically complete proteins” since these provide good deal of

essential amino acids, namely lysine, leucine, isoleucine, tryptophan, valine, methionine, phenylalanine, threonine and histidine. On the contrary, proteins of vegetable origin are usually “biologically incomplete” since they lack one or more of the essential amino acids. However, when different vegetable sources of protein are combined, result is a product that is likely to provide all the essential amino acids. Higher amounts of vegetable proteins are needed to make allowance for low biological value (Table 11.6).

Biologic value is defined as the fraction of absorbed nitrogen retained in the body for growth or maintenance. It is 100 for egg protein which is regarded as the “reference protein”, 75 for milk and fish and 67 for rice.

Table 11.6: Daily requirement for proteins

Age range (years)	Protein requirement (g/kg)
Under 1	3.5 to 2.6
1 to 3	2.5 to 2.0
4 to 6	3.0
7 to 9	2.8
10 to 12	2.0
13 to 15	1.7
16 to 19	1.5
Adult	1.0

CARBOHYDRATES

Maximum bulk (55-60%) of calories (energy) needs to be obtained from carbohydrates. In fact, the balance of the calories needed, after meeting the needs of proteins and fats, is provided by this constituent.

Carbohydrates are of two types:

1. Simple which may be monosaccharides (glucose, fructose, galactose, ribose, dextroxyribose) and disaccharides (sucrose, lactose, maltose)
 2. Complex (polysaccharides): starch, glycogen, fiber.
- With the exception of fiber, all carbohydrates are converted to glucose which is either employed as a fuel by the brain and muscles or stored in liver and muscles as glycogen. Carbohydrates consumed in excess are converted to fat.

Fiber (polysaccharides like cellulose, hemicellulose, pectin, gums, mucilages; nonpolysaccharides like lignins), a constituent of plant cell, mainly remains unabsorbed, forming bulk of the diet. Its food value is negligible. It is important for normal functioning of the GIT, preventing and even curing chronic constipation. Important fiber-containing foods include cereals,

fruits, vegetables and dried beans. Very high fiber intake may interfere with bioavailability of minerals (e.g. calcium-deficiency rickets).

FATS

Whereas carbohydrates are readily available source of energy, fats constitute concentrated energy-giving element, thereby enhancing the calories without much increase in bulk. The minimal requirements are not accurately defined. Usually up to 30% of total energy should be from fats (3.5% of calories should be supplied by *linoleic acid* and 0.3% from linolenic acid). Since human body is incapable of synthesizing this acid, it has got to be supplied in diet. Its deficiency in infants causes dryness and thickening of the skin with desquamation and intertrigo.

Important lipids are: triglycerides (fats and oils), phospholipids (lecithin) and sterols (cholesterol).

Depending on the length of the carbon, fatty acid may be

- Short-chained
- Medium-chained
- Long-chained

Depending on the saturation, triglycerides may be

- Saturated
- Unsaturated: Monounsaturated and polyunsaturated.

Saturated fatty acids are obtained from meat and coconut oil. Human body can also produce it from carbohydrates and proteins.

Unsaturated fatty acids are obtained from vegetables, nuts and seeds. Whereas monounsaturated fatty acids (MUFA) such as oleic acid may also be produced by the body, polyunsaturated fatty acids (PUFA), also called essential fatty acids (EFA), must be provided by the dietary sources. PUFA consists of omega-6 fatty acids (linoleic acid, arachidonic acid) present in normal balanced diet and omega-3 fatty acids e.g. linolenic acid, eicosapentaenoic acid (EPA) and docosahexaenoic acid (DHA) which are present in fish and seafoods.

Lecithin is a major component of cell membrane. It is synthesized by the liver.

Though cholesterol, an important component of cell membrane, may be produced by the human liver, its dietary sources include animal fats (egg, meat especially kidney and liver, cheese, desi ghee). It may

be transformed to hormones, vitamin D and bile. The daily intake of cholesterol should not exceed 250-300 mg/day.

VITAMINS

Table 11.7 summarizes the requirements of vitamins which are essential for the maintenance of good health.

Table 11.7: Daily requirement for vitamins

Vitamins	Requirement
A	1,500 to 5,000 IU
B, (thiamine)	0.5 to 1.5 mg
B ₂ (riboflavin)	0.5 to 2.5 mg
Niacin (niacinamide, nicotinamide, nicotinic acid)	0 to 20 mg
B ₆ (pyridoxine)	0.4 to 1.4 mg
B ₁₂ (cyanocobalamin)	1 to 1.5 mcg
Folic acid	25 to 1000 mcg
C	30 to 50 mg
D	400 IU
E	4 to 5 IU

MINERALS AND TRACE ELEMENTS

Cations like calcium, magnesium, sodium and potassium and anions like phosphorus, sulfur and chloride which are needed in amounts exceeding 100 mg/day are called "macrominerals". Elements like iron, zinc, copper, cobalt, iodine, selenium, molybdenum and chromium which are needed in very small amounts (up to 100-200 mcg/g matrix) are called *microminerals*. The recommended intake of important minerals is given in Table 11.8.

Table 11.8: Daily requirement for minerals

Mineral	Requirement
Iron	Infants: 1 mg/kg (6 to 10 mg) 1 to 3 years: 15 mg 3 to 12 years: 10 mg
Calcium	12 to 18 years: 18 mg Infants: 400 to 600 mg 1 to 10 years: 0.7 to 1.0 g Over 10 years: 1.2 to 1.5 g
Potassium	1.5 mEq/kg (1 to 2 g)
Sodium	2.0 mEq/kg
Zinc	0.3 or more mg/kg
Magnesium	Infants: 40 to 70 mg 1 to 3 years: 100 to 150 mg 3 to 12 years: 200 to 300 mg 12 to 18 years: 300 to 350 mg
Iodine	0.2 mg
Copper	0.05 to 0.1 mg/kg
Fluorine	0.5 to 1 mg

Iron, available from food, is of two types, namely heme and nonheme. Heme iron is found in nonveg foods, say meat, liver, chicken, and fish. Around 15-35% heme iron gets absorbed from the gut. Nonheme iron is present in plants, legumes, eggs, milk and cereals. Its absorption is much less, i.e. hardly 1%. Several factors influence its absorption (Table 11.9). During adolescence, iron needs enhance. This is especially true in case of menstruating teenagers.

Zinc is normally present in our body in sufficient amount. No supplementation is, therefore, required by the healthy individuals. In certain situations, say persistent diarrhea, malnutrition, ITS, and acrodermatitis enteropathica, zinc deficiency occurs and, therefore, zinc supplementation is strongly recommended to hasten recovery. Normal daily requirement of zinc is 4-6 mg/day. Excess of zinc intake may be complicated by copper deficiency.

Table 11.10 lists salient features of important minerals.

ANTIOXIDANTS

The term, *free radicals*, refers to atoms or molecules that contain one or more unpaired electrons that are capable of altering (usually enhancing) their chemical reactivity and cause tissue damage. These are produced in large amounts during all tissue activities

Table 11.9: Foods affecting absorption of iron from the gut

Absorption enhanced	Absorption reduced
Vitamin C-rich foods	Tea
Guava	Coffee
Lemon	Maize
Orange	Phytates (whole meal bread)
Tomatoes	
Indian gooseberry	
Foods containing heme iron	
Liver	
Meat	
Chicken .	
Fish	
Fermented/germinated foods	

(infection, phagocytosis, tissue injury, ischemia-perfusion). Examples of free radicals are superoxide anions, singlet oxygen, peroxide anion, hydroxyl radical and hydrogen peroxide.

To counter the free radicals, defenses are provided in the form of *antioxidants* which are defined as substances in food that significantly decrease the adverse effects of free radicals. Examples of antioxidants are superoxide dismutase, transferrin, glutathione peroxidase, vitamin C (ascorbic acid), vitamin E (tocopherol), beta-carotene, selenium, zinc, iron, manganese, nicotinamide, riboflavin, and lycopene.

Table 11.10: Salient features of important minerals/trace elements/micronutrients

Mineral/ trace element	Source	Deficiency	Excess
Iron	Green vegetables, meat, yolk, whole grains, nuts, legumes. Milk, especially breastmilk, is a poor source.	Microcytic-hypochromic anemia	Hemosiderosis; poisoning
Zinc	Cheese, nuts, grains, meat, fish	Dwarfism with iron-deficiency anemia, hyperpigmentation, hepatosplenomegaly, hypogonadism; acrodermatitis enteropathica: poor wound healing; depressed immunocompetence, ITS, LBW,	Gastrointestinal upset, copper deficiency, reduced high density lipoprotein
Copper	Legumes, nuts, whole grains, meat, liver, oyster (shell-fish)	Refractory anemia, osteoporosis, neutropenia, depigmentation, ataxia, raised serum cholesterol	Indian childhood cirrhosis (ICC)
Magnesium	Cereals, legumes, nuts, meat, milk	Tetany	None
Calcium	Milk and its products, fish, green leafy vegetables	Tetany rickets	Renal stones, heart block
Phosphorus	Milk and its products, fish, green leafy vegetables	Rickets	Tetany
Iodine	Sea-foods, vegetables from iodine-rich soil, iodized salt	Goiter, cretinism	Goiter
Fluoride	Sea-food, tea	Dental caries	Fluorosis
Chromium	Drinking water, animal foods, yeast	Impaired glucose tolerance; diabetes mellitus in animals	None

Excess of free radicals results either from their higher production or from inadequate antioxidant defense. Disorders in which free radicals appear to play a significant role include retinopathy of prematurity, Rh hemolytic disease, hemolytic anemia of the newborn, hypoxic-ischemic encephalopathy, septicemia, intraventricular hemorrhage, bronchopulmonary dysplasia, ARDS, necrotizing enterocolitis, inflammatory bowel disease, advanced PEM (kwashiorkor), cholestatic liver disease, pancreatitis, iron-overload (hemochromatosis) and copper-overload (Wilson disease, ICC).

Recently, a number of synthetic antioxidants N-acetyl cysteine, Glutathione, glutathione peroxidase analogue (ebselen), coenzyme Q derivatives and superoxide dismutase are available. These are yet to be successfully tried in humans.

INDIAN SCENARIO

Survey conducted by the National Nutrition Monitoring Bureau (NNMB) indicate that diet of the Indian preschoolers is grossly deficient in each and every category of food (Table 11.11).

Overall, it is the deficiency of calories (energy) whereas protein intake is, by and large, satisfactory. A noteworthy observation is that diet of children

Table 11.11: National Nutrition Monitoring Bureau (NNMB) survey data on actual *vis-a-vis* recommended dietary consumption by Indian preschoolers as per Indian Council of Medical Research (ICMR) document

Dietary item	Actual intake	Recommended intake
Cereals (g)	147	150-200
Pulses (g)	16	40-50
Leafy vegetables (g)	4	50-75
Other vegetables (g)	14	30-50
Fruits (g)	7	40-50
Milk and milk products (g)	80	200
Fats and oils (g)	4	20-25
Flesh foods (g)	4	30
Sugar and jaggery (g)	5	30-40
Calories (kcal)	758	1200-1700
Protein (g)	22-30	22-30
Iron (mg)	6.9	11.5-18.4
Calcium (mg)	193	400
Vitamin A (mcg)	220	400
Riboflavin (mg)	-	0.7-1.0

belonging to the higher strata of society show intake of protein that is in excess. It is, therefore, important to lay stress on total intake of food rather than just protein as is often done in practice.

Table 11.12 presents the recommended balanced diets for children.

Table 11.13 gives nutritive value of some commonly used foods in India as per the ICMR with minor modifications.

Table 11.12: Balanced diets for children

	Preschool children				School children			
	1 to 3 years		4 to 6 years		7 to 9 years		10 to 12 years	
	Veg. (g)	Nonveg. (g)	Veg. (g)	Nonveg. (g)	Veg. (g)	Nonveg. (g)	Veg. (g)	Nonveg. (g)
Cereals	150	150	200	200	250	250	320	320
Pulses	50	40	60	50	70	60	70	60
Green leafy vegetables	50	50	75	75	75	75	100	100
Other vegetables/roots and tubers	30	30	50	50	50	50	75	75
Fruits	50	50	50	50	50	50	50	50
Milk	300	200	250	200	250	200	250	200
Fats and oils	20	20	25	25	30	30	35	35
Meat fish and eggs	-	30	-	30	-	30	-	30
Sugar and jaggery	30	30	40	40	50	50	50	50

Table 11.13: Nutritive value of commonly used foods (per 100 g)

Foodstuffs	Calories	Proteins (g)	Foodstuffs	Calories	Proteins (g)
<i>Cereals</i>			<i>Nuts</i>		
Wheat	346	11.8	Coconut (dry)	662	6.8
Rice	346	6.5	Cashew nut	596	21.2
Maize	325	4.7	Groundnut	549	26.7
Wheat-flour	348	11.0	<i>Fruits</i>		
<i>Pulses</i>			Apple	55	0.3
Soyabean	432	43.2	Pineapple	46	0.4
Green gram	348	24.5	Orange	53	0.3
Black gram (dal)	347	24.0	Guava	51	0.9
Bengal gram (whole)	360	17.1	Tomato (ripe)	20	0.9
Bengal gram (dal)	372	20.8	Pomegranate	65	1.6
Peas (dry)	315	19.7	Apricot	51	0.6
<i>Leafy Vegetables</i>			Mango (ripe)	53	1.0
Onion tops	61	4.7	Lemon	57	1.0
Spinach	26	2.0	Lichi	61	1.1
Mustard leaves	34	4.0	<i>Flesh Foods</i>		
Cabbage	27	1.8	Egg	173	13.5
Cauliflower leaves	67	5.9	Goat meat	118	21.4
<i>Roots and Tubers</i>			Mutton	194	18.5
Onion	49	1.4	Chicken	300	25
Carrot	48	0.9	Fish	80 to 100	18 to 20
Potato	97	1.6	<i>Milk Products</i>		
Turnip	29	0.5	Cow's milk	66	3.2
<i>Other Vegetables</i>			Buffalo's milk	110	4.3
Amla (India gooseberry)	58	0.5	Human milk	66	1.1
Cauliflower	30	2.6	<i>Miscellaneous</i>		
Pumpkin	25	1.4	Bread	245	7.8
French beans	48	3.8	Sago	351	0.2
			Sugar	398	0.1
			Jaggery	383	0.4
			Oil or ghee	900	Nil

FURTHER READING

Articles/Chapters

1. Gupte S. Marasmus and kwashiorkor. *Pediatrics* 1975; 56: 152-153.
2. Gupte S. Perspectives in infant nutrition. In Gupte S (Ed): *Newer Horizons in Tropical Pediatrics* 2nd edn., New Delhi: Jaypee 1986:206-243.
3. Park K. Nutrition and health. In *Park's Textbook of*

Preventive and Social Medicine 19th edn., Jabalpur: Banarsidas Bhanot 2007:480-583.

Books/Monographs

1. Ghosh S (Ed). *Nutrition and Child Care: A Practical Guide*. New Delhi: Jaypee 2000:1-12.
2. Indian Council of Medical Research: *Dietary Allowances for Indians*. 1968: Supp Rep Ser No. 60.
3. Indian Council of Medical Research. *Recommended Dietary Intakes for Indians*. New Delhi: ICMR 1990.

CHAPTER



12

Infant Feeding

Suraj Gupte, EM Gomez

INTRODUCTION

Infant feeding is of great importance. It is a “must” to meet nutritional as well as emotional and psychological needs of the infant.

The basic food for infant feeding is milk. Breast-feeding is the most natural method and, in fact, the supreme gift. Artificial feeding should not be the first choice, except for a compulsive situation. It exposes the infant to risks, especially infections, leading to considerable morbidity and mortality, especially in the developing world.

ANATOMICAL ASPECTS OF LACTATION

Milk is produced in the sac-like spaces, *alveoli*, of the glandular tissue of breast. From alveoli, about 20 small ducts carry milk to their own dilated ends, *lactiferous sinuses*, which lie under the areola and store milk. From these sinuses, milk passes on to the nipple for supply

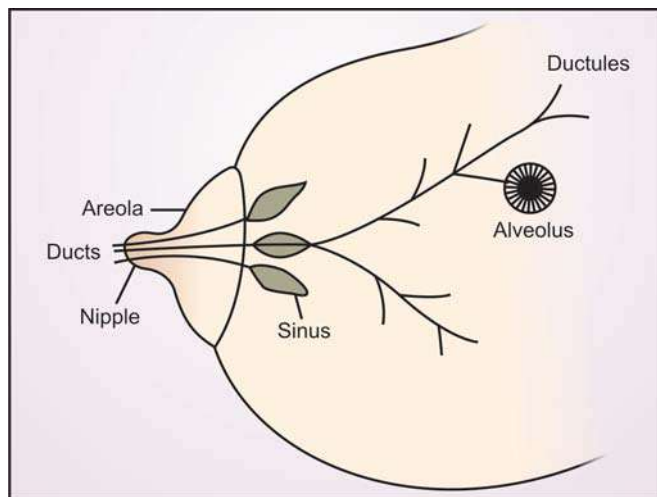

Fig. 12.1: Anatomy of breast

to the infant. However, it is important for the infant to suckle the nipple before milk gets drawn out of the sinuses and the nipple (Fig. 12.1).

PHYSIOLOGY OF LACTATION

In Relation to Mother

Prolactin Milk-secreting Reflex Suckling* by baby at breast stimulates alveolar cells of the breast to secrete milk through secretion of the hormone, *prolactin*, by the anterior pituitary (Fig. 12.2). Prolactin level reaches the peak around 30 minutes of initiation of breast feeding, thereby getting ready milk for the next feed. Since pituitary gland secretes more prolactin during the night, breastfeeding at night specially helps to keep good supply of milk.

Oxytocin Milk Ejector Reflex Suckling by the baby sends sensory impulses from the nipple to the posterior pituitary gland (Fig. 12.3). The hormone,

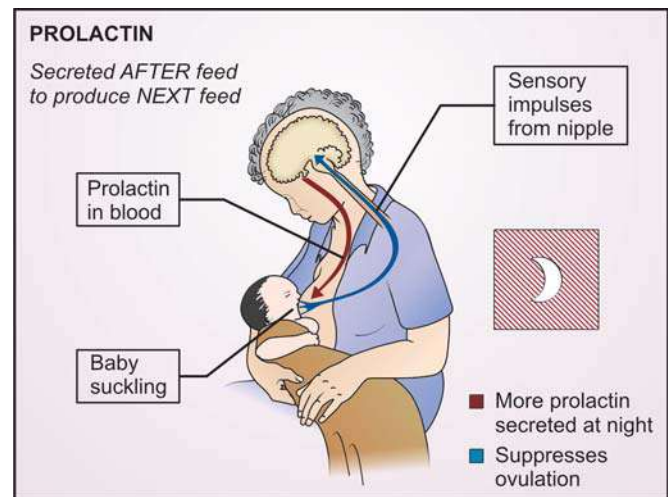

Fig. 12.2: Prolactin milk secreting reflex

*. In relation to breastfeeding, “suckling” is more appropriate term than “sucking”

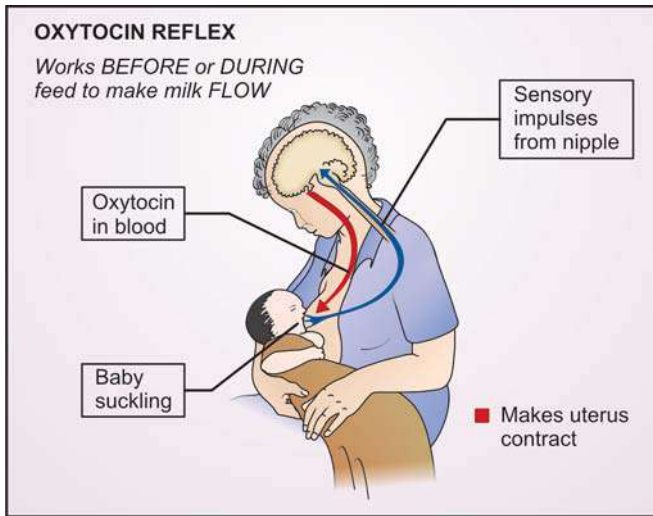

Fig. 12.3: Oxytocin milk ejection reflex

oxytocin, secreted by the gland reaches through blood to the breast, making the muscle cells around the alveolar cells contract. Thus, milk, which has collected in the alveoli, flows along the ducts to the lactiferous sinuses.

In Relation to the Infant

Rooting reflex guides the infant to reach the nipple and to have his mouth properly attached to the breast. A good attachment (termed “latching”) with nipple and enough of areola into infant’s mouth is essential for effective suckling.

Suckling reflex helps the infant to draw out milk from mother’s breast. It consists of drawing the nipple and areola into the mouth, compressing it between jaw-tongue and palate and then drawing out milk by peristaltic movements of the tongue.

Swallowing reflex helps the baby to swallow milk when mouth is full of it (after one to three suckles). He takes the breath after swallowing.

It takes about a second or so for the “suckle-swallow-breathe” cycle.

BREASTFEEDING

Human milk is decidedly superior to other milks (Fig. 12.4). It is remarkably adapted to the requirements of the infant and provides the best start in life. Exclusive breastfeeding, therefore, deserves encouragement at least for first 6 months and preferably for upto 2 years. When it is felt that the



Fig. 12.4: Breastfeeding: It is not only the best but the “must” for the baby

mother may not be able to supply enough of proteins from outside, she should be allowed to continue to breastfeed her baby even longer.

According to a WHO/UNICEF document, at least one million deaths per year from diarrhea and infections are absolutely preventable through breastfeeding.

Advantages/Benefits of Human Milk

For the Infant

- **Tailor-made composition** Human milk has a composition that is ideally tailored to the requirements of a small infant.

Table 12.1 summarises the salient features of its composition in comparison with those of cow and buffalo milk.

Table 12.1: Composition of human, cow and buffalo milk

Components	Human	Cow	Buffalo
Proteins (%)	1.2	3.5	4.2
Fat (g%)	3.8	3.7	8.0
Calories/100 ml	66	66 80 to 120	
Water (%)	88	87	83
Lactose (%)	7.0	4.5	4.8
Iron (mg%)	0.05	0.04	0.2
Vitamin A (IU/100 ml)	170 to 670	140 to 280	80
Vitamin C (mg%)	2 to 6	1 to 4	1 to 4
Vitamin D (IU/100 ml)	2.2	1.4	–
Vitamin K (mcg/100 ml)	1.5	6.0	–
Calcium (mg%)	35	11.5	–
Phosphorus (mg%)	15	9.0	–
Zinc (mg%)	0.12	0.4	–

- It is always fresh, pure and ready made, requiring no preparations. It is at the right temperature. It is uncontaminated and aseptic. It is perhaps because of this factor also that incidence of respiratory and gastrointestinal infections in breastfed infants is far less than that reported in bottlefed babies.
- *Protection against allergy* Breastfed babies have 7 times less chances of an allergy.
- *Immunoprotection* Human milk protects against certain diseases. It contains lactoferrin, a substance that inhibits growth of *E. coli*, a common cause of infantile gastroenteritis. Also, it assists in gradually establishing the organism, *Lactobacillus bifidus*, in the baby's intestine. This organism is of help in digestion of sugar. Furthermore, it contains agents against *Staphylococcus* group of organisms which are responsible for septicemia of the newborn.
- Breast milk is also said to play significant role in controlling respiratory and diarrheal diseases.
- *Bonding* Breastfeeding establishes healthy mother-child relationship. This is due to the psychophysiologic interaction that occurs during the act of feeding. The mother derives much satisfaction and a sense of fulfillment from nursing her baby successfully.
- Human milk possibly prevents arteriosclerotic disease later in life.
- *Protection against ulcerative colitis* It has now been demonstrated by several investigations that adults who had breastfeeding as infant suffer much less from ulcerative colitis than others.
- *Miscellaneous hypernatremic dehydration* which may prove disastrous to an infant's brain seldom occurs in breastfed babies. Evidence has also pooled up, suggesting that incidence of obesity in breastfed babies is "far less". Also breastfed infants stand less chance of suffering from neonatal convulsions, dental caries and sudden infant death syndrome (SIDS).

For the Mother

- Breastfeeding helps in spacing children since chance of conception in a lactating mother are less.
- Incidence of breast cancer in such mothers is relatively very little.
- Breastfeeding also helps in slimming by enabling uterus to return to normal size and also drains away extra fat accumulated during pregnancy.

For the Community

- It is inexpensive, costing virtually nothing and thus economic for individual family, community as well as national point of view.
- It promotes family planning.
- It contributes to reduction in infant morbidity and mortality.

Contraindications

There is virtually no absolute contraindication, excepting malignancy. Table 12.2 lists situations where breastfeeding may be temporarily avoided.

Breastfeeding Schedule

Breastfeeding should be initiated as early as possible, preferably within half an hour of birth. It should be "exclusive" (no other food or water be given).

Feeding should preferably be given on demand. The baby should be hungry at the time of feeding, and, he should be satisfied at the end of nursing session.

The adequacy of milk supply is indicated by:

- (a) the baby sleeps for 2 to 4 hours after the feed, and
- (b) he gains weight satisfactorily.

The so-called "test-feed" involves weighing the baby before and after the mother has nursed him. It is not a very satisfactory method of assessing the

Table 12.2: Situations where breastfeeding may be avoided

In Mother

- Chronic diseases such as active tuberculosis, leprosy, malignancy, beriberi, AIDS, etc. Many authorities advocate continuing breastfeeding in the first two provided chemotherapeutic coverage is being given.
- Mothers stubbornly addicted to alcohol or heavy doses of some drugs. Those on heavy metals, phenobarbital, hydantoin, steroids, etc. should also not be allowed to breastfeed their babies.
- Psychosis.
- Local conditions, e.g. breast abscess, cracked nipples, etc. Breastfeeding must be resumed as soon as possible.

In Infant

- Gross prematurity of the baby or other conditions in which the newborn cannot suckle.
- Inborn errors such as phenylketonuria, galactosemia or lactose intolerance.
- *Breast-milk jaundice*, provided that serum bilirubin approaches critical level.
- Biological mother may avoid breastfeeding an infant who is to be passed on to another couple.

adequacy of milk supply. Moreover, it may start worrying the mother in case of gains which, she thinks, are less than what she expects. This causes undue anxiety to her, thus further reducing the *let down reflex* and the milk supply.

Breastfeeding Technique and Some Basic Principles

1. Breastfeeding should be done in as *clean and safe a manner* as possible.
2. The mother and the baby should be *comfortable and relaxed* at the feeding time.
3. She should be well conversant with “how to put the baby to breast and how to remove him off it.”
4. *Correct position* consists in supporting whole body of the infant so that it faces the mother and the head and body are in the same plane, and his abdomen touches mother’s abdomen.
5. *Good attachment* of infant’s mouth on mother’s areola and nipple is important for good suckling. It is indicated by
 - Infant’s mouth wide open
 - Infant’s lower lip turned outward
 - Infant’s chin touches mother’s breast
 - Most of areola inside infant’s mouth.
4. At least one breast should be completely emptied at every, sitting.
5. In the case of a working mother, her “expressed” milk can be spoonfed to the baby in her absence. The mothers should be conversant with the technique of expressing milk. Using both hands, she should squeeze gently from the base of the breast towards the areola and nipple. Then the breast and areola should be squeezed between fingers and thumbs and the milk collected in a clean container. The container should be stored in a cool place. If stored outside the refrigerator, it has got to be used within 12 hours. Just before feeding, this milk should be warmed by placing the container in a bowl of hot water.
6. Starting from the initial 5 minutes, the nursing time can be gradually increased to 15 to 20 minutes in the subsequent days. Breastfeeding until 4 to 6 months of age should be infant’s exclusive intake. He need not be given even water, not to speak of supplementary feeds. There is now sufficient evidence that *exclusive breastfeeding* can maintain hydration, urine output, urinary specific gravity and rectal temperature without water supplementation even at environmental temperatures varying from 23 to 41°C and relative humidity from 15 to 96%. On the other hand, early supplementation may lead to infection, lactation failure and dilution of beneficial effects of breastfeeding.
7. In order to “kick out” the swallowed air, the act of nursing should be followed by *burping*. It consists in holding the baby erect over mother’s shoulder or making him sit in mother’s lap and then patting or rubbing his back so that he eructates the swallowed air. Failure to do so may cause regurgitation, vomiting, and even abdominal pain.
8. Mother should give adequate attention to her diet, personal hygienic and health and have sufficient rest. As far as possible, she should avoid unnecessary use of drugs which may have adverse effects on the baby.

A contented baby is a good guide as regards the adequacy of milk supply. A contented baby sleeps well after feed, is playful and passes adequate urine. The most reliable criterion of adequate supply of breast milk and growth of the baby is the weight gain. *A baby who gains less than 500 g in any 4-week period in first 3 months of life or 200 g in any 4-weeks period in second three months is likely to be malnourished later.*

COMMON BREASTFEEDING PROBLEMS

Inverted or Retracted Nipples

Since these may cause difficulty in breastfeeding, the mother is advised to manually stimulate, stretch and roll out the nipples to make them protractile (prominent) several times a day, especially before offering the feed. In a large majority, the condition resolves in a couple of weeks. Else, the plastic syringe method may be employed (Fig. 12.5).

Sore Nipple

The causes include poor attachment, frequent application of soap, forcibly pulling the infant off the breast while he is still engrossed in sucking, natal tooth and fungal infection of the nipple. Application of hind milk and airing after the feeds resolve the problem.

Breast Engorgement

Swollen, congested and painful breast may result from overdistention of alveoli when adequate emptying of

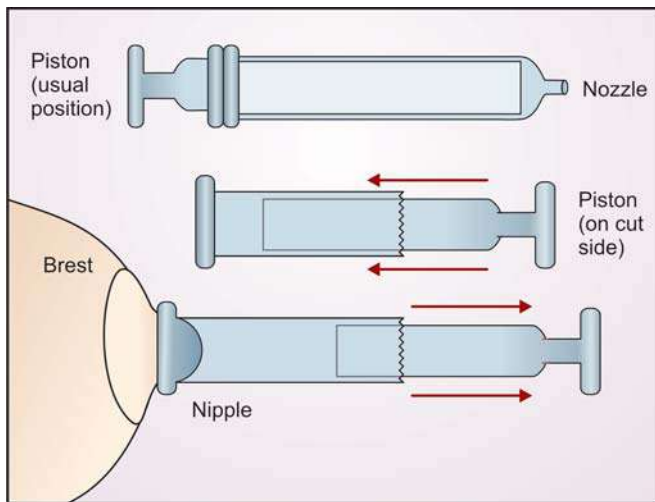

Fig 12.5: Plastic syringe method for retracted/inverted nipples. *Step 1:* cut the nozzle-end of a plastic syringe. *Step 2:* Introduce the plunger from the cut-end rather than the normal smooth end. *Step 3:* Guide the mother to attach the smooth end of the syringe over the nipple and then gently pull out the plunger. As a result of negative pressure thus created, the nipple protrudes out. Once suction is released and syringe removed, the infant is allowed to attach on the breast for feeding. The method may need application several times in a day for some days

breast does not occur because of delayed or infrequent feeding, faulty attachment or incorrect positioning of the infant at the breast.

Treatment consists in application of warm water packs and oral analgesics. Gentle expression of milk assists in softening the breast. Thereafter, the infant should be put to breast, ensuring correct positioning and attachment.

Breast Abscess

It may result from delayed attention to engorged breast, infected sore or cracked nipple, mastitis or a blocked duct. It may cause high fever in addition to local manifestations. Treatment is incision and drainage along with antibiotics and analgesics.

“Not Enough Milk”

Though a number of factors (wrong technique/positioning, infrequent or hurried BF, local problems of breast, etc) can cause “not enough milk”, at times mother’s impression is not well founded. In such cases, the infant demonstrates adequate weight gain, passes urine at least 6 times/day and sleeps for 2-3 hours after each feed. Such mothers need reassurance. In others, it is important to look for the reason and offer treatment accordingly.

LACTATION FAILURE

Definition

Lactation failure is failure on the part of the breasts to produce adequate quantity of milk which manifests as failure to sustain growth in a normal infant within 2 standard deviations of the standard for the infant in the first 6 months of age.

Complete LF means total absence of milk flow or secretion of only a few drops of milk following regular suckling for a period of at least 7 days. *Partial LF* means insufficient milk flow by the mother who is otherwise regularly breastfeeding her baby so that the infant needs supplementation by artificial feeding for sustaining growth (Fig. 12.6).

Etiology

LF is usually not the cause, but a consequence of a number of factors which are responsible for introduction of top milk under the wrong notion of “not enough milk”, or because of maternal-child separation, working mothers, sore/cracked nipples, etc (Table 12.3).

The sequence of events in the development of lactation failure is sketched in Figure 12.7. It will be seen that in a vast majority of the cases it is more or less preventable

Prevention

The most important preventive measures are through antenatal check-up of the breasts, antenatal preparation of the mother for breastfeeding, feeding

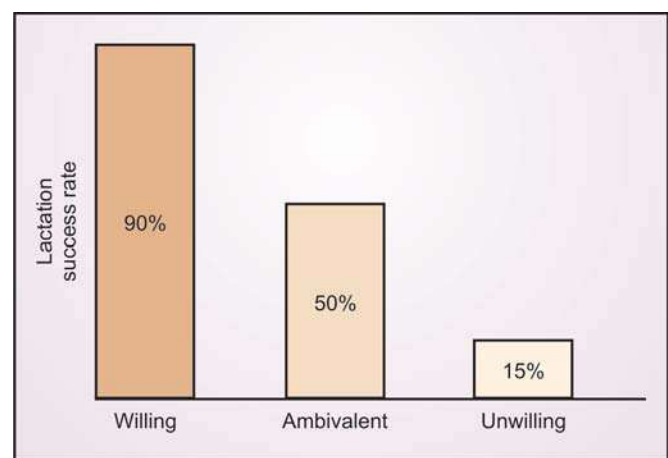

Fig. 12.6: Attitude of the mother has a great bearing on success of lactation

Table 12.3: Etiology of lactation failure

Maternal factors

Psychosocial Lack of motivation/confidence/will, dislike of BF because of wrong notions, stress and anxiety, rejection of baby, previous unpleasant experience, undue concern for figure, aping the west, influence of advertisements favoring breastmilk substitutes.

Physical: Breast conditions, e.g. nipples that are retracted, cracked or sore, painful conditions, e.g. mastitis, engorgement or abscess, malnutrition, sickness, pregnancy, contraceptive pill, alcoholism, smoking, working mother.

Infant factors

Sick infant, prematurity, suckling problem, e.g. cleft palate, nasal block, oral thrush

Feeding factors

Prelacteal feeds, delayed initiation, poor technique, introduction of bottle

as early as possible after delivery, remedial measures for anatomical defects in the breasts and complete emptying of the breasts. If necessary, even manual expression of milk following feeds may be done.

Most of lactation failure can be prevented if the pediatrician forms a part of the team for the antenatal care, and the breasts of every expectant mother are carefully examined.

Treatment

Metoclopramide and chlorpromazine may help certain mother with lactation failure to revert to normal milk production through their galactagogue effect. Nevertheless, remember, the best galactagogue is indeed the frequent suckling.

Relactation in Partial Lactation Failure

Satisfactory relactation in these mothers is attained by motivation and encouragement. They need to be educated on the supremacy of breast milk and actively involved in achieving success with "commitment for the cause". As the days pass by, the amount of top feed needs to be reduced in increments until the infant is entirely of mother's milk.

Relactation in Complete Lactation Failure

This is rather more difficult situation. In addition to motivation, encouragement and moral support, the following actions are warranted:

- Nipple stimulation exercises by nipple stroking, massaging the breast and rolling the nipple between thumb and the index finger.

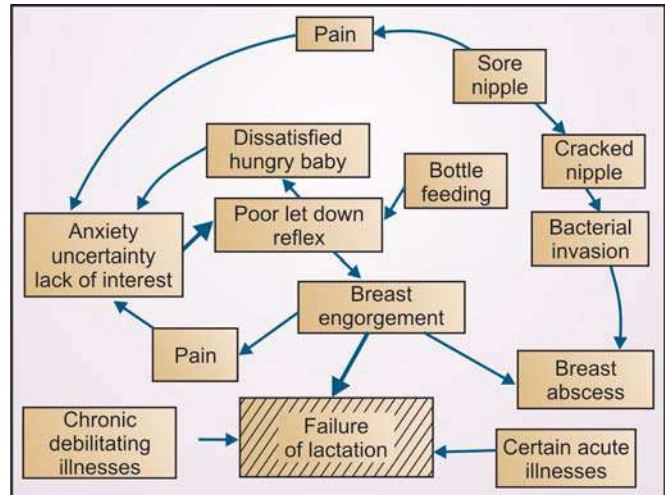

Fig. 12.7: Sequence of events in lactation failure

- Frequent suckling, at least 8 to 10 times a day, each session lasting 10 to 15 minutes for each breast.
- Drop and drip method may be employed if the infant fails to suckle for 8 to 10 minutes. The method consists in expressing some breastmilk or topmilk in a cup and gradually pouring it over as drops over the breast. As the drops slide over the nipple down into infant's mouth, he is stimulated to suckle at the breast.
- Nursing supplement may be used to induce suckling in the infant. This gadget consists of a fine infant feeding tube. The tube is employed as a drawing straw. It is made to pass from milk in a cup to the infant's mouth. Its end is placed along with mother's nipple so that the baby suckles at both the nipple and the tube simultaneously. As he suckles when milk passes into his mouth, the nipple gets stimulated, thereby enhancing the prolactin reflex which increases the milk production.

Evidence of Successful Relactation

- Appearance of first milk secretion in 2 to 10 days.
- Partial restoration of breastfeeding with reduction of top feed to half of the initial.
- Complete restoration of breastfeeding with total withdrawal of top feed.
- Satisfactory weight gain by the infant.

COMPLEMENTARY FEEDING

The term *weaning* means "to be taken off the breasts" or "introduction of top feed". The latter meaning is more relevant in infant nutrition. Though in vogue for several decades, the "weaning" is an inappropriate

terminology. The better terminology is *complementary feeding*.

Definition

By definition, complementary feeding means introduction of nutritious foods over and above breastfeeding. These energy-dense foods should be cost-effective, affordable, easily available and well-tolerated.

Recommended Age

Just after six months of age is the most appropriate time for introducing complementary feeding. *The whole process should be gradually completed by 9 months to 1 year of age* when the child should be taking almost the adult diet.

Whereas delayed introduction of complementary foods is known to cause malnutrition and growth retardation, premature introduction of such foods exposes to the risk of infections and the resultant morbidity and mortality.

Besides infections, too early introduction of complimentary feeds, including cow milk, or buffalo milk has other problems (Table 12.4) and is not recommended except under special circumstances such as when the mother is not able to produce sufficient milk despite the best of efforts.

Table 12.4: Problems associated with too early initiation of complementary feeds

Short-term

- Decreased suckling frequency and intensity, leading to decreased milk production.
- Iron deficiency unless cereal preparations used are rich in iron.
- Hyponatremia
- Weaning diarrhea

Long-term

- Malnutrition in the poor
- Obesity in the affluent
- Hypertension
- Arteriosclerosis

Prerequisites/ Attributes of an Ideal Complementary Food

Home-made/available: These foods are fresh, easily available, economical and provide exposure to variety. Home-available ready-made foods e.g. biscuits, bread, pastry, etc, come in handy at odd times.

Fresh and hygienic: Food must be freshly and hygienically prepared, avoiding prolonged storage.

Palatable: Soft, easy to eat and tasty

Cost-effective/affordable: The foods should be in keeping with the socioeconomic status of the family.

Culturally acceptable: It is preferable to employ available food and culturally acceptable foods normally taken by the family with appropriate modification.

Energy dense: Food can be made energy dense by adding oils and fat. In addition, such an addition increases palatability of food, provides essential fatty acids and enhances absorption of some vitamins and micronutrients. Amylase-rich foods can be prepared by germinating cereal flours. Sprouting increases the vitamin B content. Malting increases the digestibility and vitamin (riboflavin and niacin) and iron content.

Types of Complementary Foods

The complementary foods can be divided into different groups (3 "A"s) based on their availability and nutritional advantages (Box 12.1)

Box 12.1: Types of complementary foods used by the community

Appropriate (first line) weaning food

Fresh home-made, locally available, culturally acceptable, hygienically prepared, energy dense and cost-effective foods like.

- Combination of cereals and pulses (khichadi, dal-rice etc.), porridge, suji, dalia, kheer, khaman dhokla, idli, dosa, ragi, rice preparations etc. in any form fortified with sugar and oil or fried.
- Mashed banana, sweet potato and potato.
- Milk added to cereals preparations.
- Sprouted legumes, nuts, dry fruits etc. depending upon the affordability.

Acceptable (second line) weaning foods

These includes home available foods like

- Breads, cakes, pastry, biscuits, cheese, icecream, etc.
- Caloric dense fruits, etc.

Avoidable (third line) weaning foods

- Commercially available artificial foods or tinned foods.
- Fast food or junk food.
- Low caloric fruits juices, soups.
- Repeatedly frie foods containing trans fatty acids (which predispose to obesity, atherosclerosis, cardiac and neurological problems in future life).

1 Complementary Feeding Regimen

To begin, with one of the foods like mashed ripe banana, mashed potato a cereal, curd, pulses, *khichri*, dalia, etc. should be introduced in the form of a soft porridge when the child is just beyond 6 months of age.

The food should be given in small amounts (say 2-3 tablespoonfuls). The amount can be built up slowly. Likewise, frequency too is increased from twice a day to 3 or 4 times a day by the fagend of the first year. Every 1 or 2 weeks, a new food may be added. If the child does not like a particular food, this may be omitted for the time being. A one-year-old should be taking the family food which, if need be may be mashed or chopped.

Germinated cereal flour or pulse flour is an amylase-rich food (ARF) and is able to dramatically reduce the viscosity of high dietary porridges. It makes an excellent weaning food.

Fish, egg, meat, etc. should be introduced later in view of the possible risk of allergy to proteins. In case of egg, begin with the "yolk". Addition of animal protein makes up for the deficiency of limiting aminoacid, methionine, which may be seen in infants exclusively on a staple cereal and a legume. Staple cereal as such is deficient in lysine but this deficiency is made up when legumes are consumed concurrently.

ARTIFICIAL (FORMULA) FEEDING

As already pointed out, only a very small proportion of the infants really require artificial feeding. The existing actual position is, however, quite different. Despite the acknowledged superiority of human milk, today artificial feeding, especially in the form of bottle feeding, has come to stay. The worse: it has, in actual fact, considerably increased with rapid industrialization.

The situation is understandable as regards the urban elite who regard breastfeeding as "time consuming", "messy", "an encroachment on activities" and so on the so forth. They find the readymade milks simple, convenient and a sort of boon to their personal freedom. The more disturbing fact is that even the urban poor and the rural women who can hardly afford the luxury of expensive artificial feed, have now been influenced by this trend. Whereas the former are mostly influenced by the

tempting publicity of the manufacturers as also by the personal and social considerations, *the village folks merely ape the urban trend.*

Let us remember: artificial feeding is an expensive affair. Imagine a baby of just 4 months of age needing almost 2.5 kg of milk powder every month and even more in the subsequent months.

What is more the artificial feeding means exposure to such hazards as underfeeding and multiple nutritional deficiencies from overdilution of the formula, gastroenteritis and other superadded infections.

Long-term sequelae of artificial feeding include lactose intolerance, obesity, atherosclerosis, relatively poor learning abilities, family breakup and population explosion.

FEEDING THE LOW BIRTHWEIGHT (LBW) INFANT

Feeding Problems of the LBW Infant

The LBW infant, known for immaturity of the gastrointestinal system, frequently suffers from one or the other feeding problem:

- Excessive crying because of the need for a higher food intake compared to the normal infant in order to make up the deficit in weight.
- High frequency of suckling difficulties.
- Incoordination between suckling and swallowing.
- Abdominal distention as he is not capable of holding a large feed in his stomach.
- Regurgitation since the cardioesophageal sphincter is lax.
- Poor tolerance for saturated fatty acids.

Notably most of the problems are secondary to immaturity of the gastrointestinal system.

Nutritional Needs of the LBW Infant

According to estimates, the LBW infant requires on an average 140 (120-150) kcal/kg/day.

Understandably, about 200 ml of milk is required to meet this demand. Attempts to attain this target right at the outset often prove futile since the infant is simply unable to cope with this much feed. A realistic and practical approach is to aim at achieving this target by second week.

As regards protein, 4-6 g/kg/day is good enough. An intake outside this range is not in the interest of the infant. Higher intake may cause retention of fluid

and solute as also high blood urea on account of renal immaturity. Rapid weight gain occurring in this situation is not in the interest of the baby. Low protein intake may cause hypoproteinemic edema and poor weight gain, further worsening the baby's nutritional status.

Over and above this, the infant also needs vitamin K at birth, and multivitamins (especially vitamins A, C, D and E), iron and folic acid, calcium, phosphorus, etc. subsequently.

Early feeding is the current recommendation—within 6-12 hours. Most centers give the first feed at about 3 hours of age. The risk of aspiration in early feeding can be minimized with careful supervision and vigilance.

Risks of delayed feeding include icterus, hypoglycemia, metabolic acidosis, metabolic acidosis and brain damage.

Method of Feeding/Providing Nutrition

Broad guidelines for fluids and nutrition of LBW infants are discussed above.

Breastfeeding

Many LBW infants, especially those weighing > 1800 g, are strong enough to suckle well from the breast. This should be encouraged. However, care should be exercised to safeguard against distention of abdomen. This is best achieved through small feeds at frequent intervals.

Breastfeeding should be considered as the preferred choice enteral feeding for all LBW babies. When it is not workable for some reason, gavage feeding (tube feeding) should be the choice, employing mother's own expressed milk. There is sufficient evidence that necrotizing enterocolitis is far less in LBW infants fed mother's milk than those on artificial feed. Further, LBW infants on own mother's milk are known to grow faster than those on another woman's milk.

Alternative Methods of Milk Feeding

Gavage (Tube) Feeding

It is needed in:

- LBW infants weighing < 1200 g or < 30 weeks gestation after initial stabilization with IV fluids.

- LBW infants weighing 1200-1800 g or < 34 weeks gestation.

Other indications of tube feeding are:

- Baby getting tired quickly.
- Baby taking > 20 min to finish the feed.

For LBW infants, recommended size of the tube is No. 6 FG (French gauge) and No 4 FG in case of complicating respiratory difficulty. On an average about 16-17 cm of tube is needed to reach the stomach from the gum margin. In a given situation, the tube may be measured from the tip of the nose to the ear lobe and further to the ansiform cartilage. The measurement should be marked of the tube per se. In case tube feeding is required for a short period, it may be passed through the mouth. For this purpose, the wet tube is placed along the side of the tongue and then into the pharynx. The head-end of the baby needs to be raised.

If tube feeding is needed for several days, it should be passed through the nasal route into the esophagus and stomach. It should be kept in place.

Once the tube has been passed—irrespective of the route—its position should be confirmed. To do this, gentle aspiration is required. The gastric fluid is usually colorless and acidic in reaction. If aspiration is difficult, some air may be injected and its entry into the stomach verified by auscultating the epigastric region.

Intermittent Feeding: The outer end of the tube is attached to a syringe (20 ml) containing milk. It is important to bear in mind that milk should not be pushed, if safety is needed. Instead it should be allowed to trickle by gravity. The time taken by each feed nearly varies from 10 to 20 minutes, depending upon the size of the feed. This is about the time taken by an ordinary feed as well.

At the end of the feed, a few ml of plain water should be pushed to rinse the tube.

If the tube is to be removed, it should be pinched so that no fluid trickles into the trachea as the end reaches past the larynx.

Continuous Feeding (Intragastric Drip): Continuous milk drip has now won pride of the place in the feeding of LEW babies. Its advantages are many, e.g.:

1. Allows high milk intake.
2. Weight gain is more.
3. Less risk of regurgitation.
4. Less risk of aspiration into the lungs.

5. Less risk of hypoglycemia.
6. Nursing time is cut.,
7. Minimal handling of the infant.

The technique of introduction of the tube into the stomach is same as in case of intermittent feeding. The outer end of tube is, however, attached to the intravenous set containing milk.

As in intermittent feeding, infants' head should remain slightly raised. His position should be supine. The tube should be changed every third day. It should be aspirated thrice daily. The bottle requires to be changed every 12 hours and the giving set every 24 hours.

"Palady"/"Katori-spoon" Feeding

The fact that even LEW neonates of 30-32 weeks gestation are good at swallowing even though their sucking may not be upto the mark forms the guiding principle of feeding by a "palady" or "katori and spoon".

In case of the "palady", the tapering snout is placed at the angle of the mouth. Then, milk is allowed to trickle slowly. The infant manages to swallow it without sucking. Repeat until the required quantity has been fed. It is good to be slow and patient, to avoid spilling of the feed.

In case of "katori and spoon", required quantity of EBM is taken in a clean medium-sized katori (or a cup). Spoon is filled with milk and placed over the lips at the corner of the mouth. Milk starts flowing into the mouth while the infant actively swallows it. Repeat the process until the calculated quantity has been fed. Avoid spillage.

It is possible to find the quantity that has been spilled by wighing the napkin around baby's neck before and after the feeding.

Expressed Breast Milk (EBM)

EBM should be first choice. Milk of the LBW baby's milk provides higher protein and calories. It is, therefore, not only species-specific but also baby specific on account of its best suitability for the infant. Expression of milk can be carried out by mother's attendant though mother herself is the best for this purpose. The choice about the manual expression or the use of a breast pump is influenced by the existing circumstances as well as mother's attitude. Table 12.5 gives the schedule for expression of breast milk.

Table 12.5: Breast milk expression

<i>First 24 hours</i>	Twice, 2 min at each breast
<i>Second 24 hours</i>	Thrice, 3 min at each breast
<i>Third 24 hours</i>	Four times, 4 min at each breast
<i>Fourth day and onward</i>	Five or 6 times, 5-10 times at each breast

Expression of milk must be done in a safe and clean manner. The concept of human milk banking now gaining popularity in the European countries poses several difficulties in the developing countries because of unfavorable climate, ignorance, illiteracy, impracticability of monitoring of each sample before administration and holder pasteurization. Nevertheless, in view of the greater need for human milk for the LEW infants, the need for modified human milk banking cannot be denied.

Expressed milk provides adequate amount of protein, energy, vitamins and copper and nearly adequate amounts of zinc, iron and magnesium which, however, are needed in yet greater measure by the LEW baby. It is poor in calcium and phosphorus. Supplementation with these nutrients is, therefore important in the care and feeding of LEW infants.

In case enough EBM from the biologic mother is not readily available, it may be collected from another lactating healthy mother.

Resort to top milk is indicated only in case of lactation failure despite best of efforts at relactation. It should be for a short period only and breastfeeding resumed as soon as possible.

Nutritional Supplements

Preterm human milk, though superior to pooled term milk, is deficient in iron, calcium, phosphorus, zinc and copper. It provides more proteins and energy but the preterm LEW infant needs yet more of these. EBM, therefore, works better when supplemented with human milk fortifier or individual nutrients. At present, the only available HMF is Lactodex-HMF (Raptakos-Brett).

Human milk fortifiers: At 2 weeks of age, human milk fortifier may be added to EBM for providing extra protein, energy and micronutrients. The dose is 2 g of Lactodex-HMF for 50 ml of EBM. The resultant fortified EBM provides additional 0.2 g protein, 0.19 g

fat, 1.2 g CHO plus calcium, phosphorus, vitamins, minerals and trace elements.

Vitamin K: Right at birth, 1 mg vitamin K should be given intramuscularly.

Multivitamin drops: Again at 2 weeks, multivitamin (including folic acid) drops should be introduced.

Iron: At about 4-8 weeks, low-dose (2-3 mg/kg/day) iron supplementation should be started.

Vitamin E, calcium and phosphorus: Supplementation with these micronutrients is recommended, especially in case of VLB W.

Intravenous (Central) Feeding

First 2 Days

For LBW of SGA (SFD) type, 90-100 ml/kg of 5-10 % glucose is recommended. For LEW of short gestation type, 60-70 ml/kg of 5-10 % glucose suffices.

Later

Since the LBW needs extra-sodium and potassium, N/5 saline with 15% potassium chloride (1 ml added to 100 ml infusate) should replace the 5-10% glucose after 2 days. The readymade Isolyte-P serves well as an alternative.

Parenteral Nutrition

It may become mandatory to resort to parenteral nutrition in the following life-threatening situations in which enteral feeding has failed to establish or central feeding is not possible for prolonged periods:

- ELBW babies (<1000g).
- LBW babies unlikely to attain full enteral nutrition by day 5 for some associated problem such as intractable diarrhea, necrotizing enterocolitis, surgically correctable GI anomaly (omphalocele, gastroschisis, tracheoesophageal fistula, malrotation with volvulus, diaphragmatic hernia, etc.), extensive bowel resection.

This regimen provides adequate fluids and electrolytes, energy (from glucose, protein and lipids), amino acids and vitamins and micronutrients for sustained growth of the LBW babies. With this method, providing around 100 kcal/kg/24 hours, a weight gain of 15 g/kg/24 hours is likely to be attained in the first week.

Parenteral nutrition may be carried out employing an indwelling central venous catheter (per cutaneous or surgically-placed) or through a peripheral vein.

It is important to be vigilant about the complications, both catheter-related and metabolic (Table 12.6).

Nonnutritive Suckling

When the LBW infant is being kept on IV fluid or tube feeding, he may be given experience of suckling by providing opportunity to suckle the empty breast. This experience stands him in good stead later at the time of transition to nutritive suckling.

This is a method of exposing a neonate, who is being kept on gavage feeding or intravenous fluids/nutrition for such reasons as prematurity, low birthweight or such illnesses as birth asphyxia, septicemia, etc. to experience of suckling on emptied breast that is expected to stand him in good stead later at the time of transition to nutritive suckling.

Characteristics

Nonnutritive suckling consists of a rhythmic alternation of bursts of rest periods with a mean intersuckling interval of 0.3 to 0.5 second.

Nutritive suckling, on the other hand, consists of almost continuous streams of suckles with a mean intersuckling interval of 0.1 second.

Table 12.6: Complications of parenteral nutrition and remedial measures

Complication	Action Recommended
Catheter-related Complications	Meticulous catheter care
Sepsis/septicemia (usually from coagulase-negative staphylococcus)	<ul style="list-style-type: none"> • Aseptic preparation of the infusate Appropriate antibiotics Removal of line if sepsis persists
Thrombosis	
Extravasation of fluid	
Accidental dislodgement of catheter	
Metabolic Complications	Biochemical and physiologic monitoring
Hyperglycemia	
Azotemia	
Nephrocalcinosis	
Hyperlipidemia	
Hypoxemia	
Hyperammonemia	
Cholestatic jaundice	
Liver disease	
Metabolic bone disease	

1 Advantages

Nonnutritive suckling influences the neonatal behavior of a preterm baby in the following ways:

1. Restless state is less frequent.
2. Behavior distress during a painful procedure is altered.
3. Oxygenation, weight gain and gut transit time are increased.
4. Nutrient absorption is improved. Intermittent changes in pressure during suckling are necessary to stimulate secretion of the lingual lipase, facilitating fat absorption.
5. Transition from gavage to breast becomes easier.
6. Nipple stimulation by repeated suckling results in enhanced milk supply.

An added advantage of nonnutritive suckling is that it provides significant 'emotional support and satisfaction to the mother who is upset by the high-risk status of the infant.

Procedure

Make sure that the procedure is carried out in a reasonably warm room to safeguard against chilling of the infant. Then, mother is asked to express out milk from each breast as much as possible. After this, the baby is allowed to suckle on each breast. The requisite amount of the expressed milk is administered by tube feeding. Gradually, the infant should be suckling on the emptied breast before each and every gavage feed.

As soon as the infant develops well sustained suckling, start direct breastfeeding. Slowly withdraw all gavage feed and let the infant be entirely on direct breastfeeding.

COMMON FEEDING PROBLEMS

Most infants, particularly newborns, suffer from such feeding problems as regurgitation, vomiting, suckling and swallowing difficulties, dehydration, fever, excessive crying, "3 months colic", change in bowel habit, underfeeding, overfeeding or "bottle addiction". All these are preventable.

Too little feed, too heavy feed, too frequent feed, wrong feeding technique, poor respect to bottle hygiene, etc. figure prominently among the underlying causes.

Regurgitation

Several babies (not breastfed) spit up a little of the feed along with swallowed air. "Possetting" is the name

given to this phenomenon. With some babies, possetting becomes a habit. They relish to bring back some milk and chew it just like a cow chews the cud. This is called "rumination". Though harmless, it does make the baby somewhat smelly. In order that he does not inhale any bit of the regurgitated milk, he should be put on his side and never on his back. This position also makes it difficult for him to regurgitate and continue with rumination.

Regurgitation need not bother unless it is interfering with the nutrition of the baby. Also, if the baby brings back the entire food, particularly more than once, there is a case for finding out the cause.

There is a notion that regurgitation is because of "wind production". It is not that the baby is a small wind-producing machine but because he has swallowed excess air with feed or as a result of crying.

The solution lies in guiding the mother about the proper technique of "burping".

Vomiting

It may be due to overfeeding, prolonged burping, too much of swallowed air, gastroenteritis or some other infection. If the baby shoots the milk half way across the room, the so-called "projectile vomiting", the possibility of hypertrophic pyloric stenosis exists.

Suckling and Swallowing Difficulties

Some difficulty in suckling is normal during the first few days. It is understandable since this is the period in which the baby and the mother are practising the technique.

Certain mechanical problems such as cleft palate, cleft lip, large tongue and nasopharyngeal obstructions as in choanal atresia, may interfere with feeding. Local conditions of the breast like cracked nipple, retracted nipple, engorgement and abscess also cause sucking difficulties.

Preterm baby is prone to have suckling and swallowing difficulties. Likewise, cardiac or respiratory disease associated with tachypnea, intracranial hemorrhage and neonatal jaundice figure among several causes of feeding difficulties.

Dehydration Fever

Disinclination to feed, fever and drowsiness may occur in some newborns about the third or fourth day of life. In such infants, one should exclude infections (not forgetting urinary tract infection) as the cause of dehydration fever.

The baby with dehydration fever may lose 5 to 15 percent of body water. Administration of additional feeds of water over about 12 hours brings down the temperature. Simultaneously, he begins to accept feed normally and gains weight.

If a fulminant infection is seriously suspected in an infant who is immature or is at risk for one or the other reason, antibiotics are recommended even if a specific site of infection cannot be recognized.

Excessive Crying

Crying in a newborn is almost always a manifestation of hunger or thirst, chilliness, need for the mother or a wet napkin.

Repeated crying may begin to get on the mother's nerves. An insecure mother may not develop the much-needed warm emotional relationship with such a baby. There are, at times, instances of baby-battering. It is not uncommon to hear a mother shouting. "What else can you do with such a rascal? He does not let me relax for a minute".

Irritability of an infant during the mother's menstrual periods is well-known observation. Whether it is related to fall in the breast milk supply, mother's irritability or some substances in breast milk during menstruation that cause discomfort to the infant is not clear.

Colic

Sometimes a baby begins crying soon after birth, particularly towards late afternoon or evening and keeps doing so during the first three months or so. This condition has been christened "three months colic", or "evening colic". None of the above mentioned causes seems to account for its occurrence. Excessive intestinal activity is said to be the cause. It is borne out by the presence of exaggerated bowel sounds as revealed by auscultation. Administration of a mild antispasmodic agent may help these infants.

Change in Bowel Habit

Infants on cow milk, especially if underfed and given inadequate fluids and sugar, may pass constipated stools—stools of hard consistency—which cause a good deal of straining and discomfort. As a result, the fear of pain may cause retention. The passage of such a

stool, on its own or following rectal examination, can lead to anal crack or fissure. Some infants start having spurious diarrhea.

Most constipated newborns respond to addition of water, some brown sugar, honey or glucose to the intake.

Magnesium hydroxide (one to three teaspoonfuls) and liquid paraffin (one to four teaspoonfuls) are often employed as stool softeners. These are, as far as possible, best avoided. We have seen at least two infants on liquid paraffin over a prolonged period who, though otherwise well nourished, developed xerophthalmia. It was attributed to prevention of absorption of vitamin A by liquid paraffin. Lipid pneumonia is another serious side-effect of the agent.

In obstinate constipation, one should exclude cretinism and congenital megacolon (Hirschsprung disease).

Recurrent episodes of loose motions are often due to poor bottle hygiene.

Underfeeding

A highly diluted formula, often due to ignorance or economic considerations, is a well-known cause of failure to gain weight. The underfed baby takes his feed quickly, showing that he has been hungry for long. Dissatisfied with the amount made available to him, he usually cries and cries until he goes to sleep. After a few hours, usually much before the due time for feed, he wakes up and cries.

Bottle Addiction

It is not infrequent to see mothers grumbling that "the little rascal refuses to part with the bottle" even at 24 months. Little do they realize that the reason is indeed rooted in their failure to have replaced the bottle by spoon and cup at about six months or little earlier. It is unwise to have a baby on bottle after one year of age.

Overfeeding

It is not a common problem in our country. Most infants, as a rule, refuse to accept excess feed. And pushing the feed forcibly is quite a difficult job. But, then, some mothers do manage to give the baby larger and larger feeds. These babies are likely to suffer from infantile obesity. That does not, however, always happen. Some just stop gaining weight. Such a baby

1 is unhappy, vomits large amount of feed, has fatty diarrhea and keeps crying.

Inexperienced Mothers

Not all mothers are good enough and well prepared for the newborn. Some are sadly lacking in self-confidence and unsure how to handle the baby. They worry too much and are very apprehensive. Their nervousness somehow influences the baby. As a result, he becomes more demanding and cries a lot to the mothers' further annoyance. This interaction may lead to rather unhealthy relationship between the mother and the baby.

We have observed such a situation very often in the case of young educated mothers who opt to live by one or to the other stereotyped handbook of baby care. They just try to blindly ape it rather than follow sound advice and their own judgement based on individual merits of the situation.

FURTHER READING

Articles/Chapters

1. Chellani H, Arya S. Breastfeeding: The supreme gift. In Gupte S (Ed): *Textbook of Pediatric Nutrition*. New Delhi: Peepee 2006: 59-65.
2. Faridi MMA, Kumar M. Not enough milk: How to do lactation management. *Pediatr Today* 2006;9:73-80.
3. Gupte S, Pal M, Abil S. Feeding of the low birthweight infants. In Gupte S (Ed): *Textbook of Pediatric Nutrition*. New Delhi: Peepee 2006:139-142.
4. Maiya PP, Karunakara BP. Artificial feeding: an avoidable option. In Gupte S (ed): *Textbook of Pediatric Nutrition*. New Delhi: Peepee 2006:100-104.
5. Naylor AJ. Baby friendly hospital initiative: protecting, promoting and supporting breastfeeding in the 21st century. *Pediatr Clin North Am* 2001;48:475-483.
6. Raghavan C. Infant feeding laws. *Nutrition* 2005;2:66-69.
7. Tiwari SK, Kale P, Agarwal S. Complementary feeding. In Gupte S (ed): *Textbook of Pediatric Nutrition*. New Delhi: Peepee 2006:106-113.

Books/Monographs

1. Anand RK, Kumta NB, Kushwaha KP, Gupta A. *The Science of Infant Feeding*. New Delhi: Jaypee 2002.
2. Gupte S. *Infant Feeding*. New Delhi: Jaypee 1981.
3. WHO *Complementary Feeding of Young Children in Developing Countries: A Review of Current Scientific Knowledge*. Geneva: WHO 1998.
4. World Health Organization. *Global Strategy for Infant and Young Child Feeding*. Geneva: WHO 2003.



Protein-energy Malnutrition

Suraj Gupte, EM Gomez

Over the recent decades, the incidence of severe malnutrition as also low birthweight infants (LBW) has gradually fallen though only to an unsatisfactory level. Nevertheless, according to the national family healthy survey 3, mild to moderate malnutrition which eventually ends up in stunted growth continues to exist in around 48% of the pediatric population. These substandard survivors are likely to suffer from consequences as poor quality of life, low cognitive development and learning skills on top of other handicaps continues to exist in around 60 percent of the pediatric population. Considerable morbidity (and, at times mortality) accompanies nutritional anemias and other micronutrient and vitamin deficiencies, directly or indirectly.

ECOLOGY OF MALNUTRITION

Ecology of malnutrition is complex (Fig. 13.1). It is customary to consider it as:

- primary*: due primarily to dietary deficiency, and
- secondary*: due to such diseases as tuberculosis or malabsorption.

In a considerable proportion of the cases, both the factors may be operative. Even children with the so-called "isolated" protein-energy malnutrition without any superimposed infection or infestation do demonstrate some degree of absorptive defect which further aggravates the state of undernutrition.

Bad Economy

Poor socioeconomic status of the family contributes a lot to development of malnutrition in the developing regions. With very low income, it is a tough task to

provide nutritious diet to the children. It is estimated that, among the downtrodden, hardly 10% of the money is spent on foods obtained from animal sources, i.e. egg, milk, curd, meat, etc. With the further pressure on the meagre income from increasing requirements, including clothing and entertainment, during modern times, still more curtailment of expenditure on food results.

Ignorance, Faulty Food Habits and Feeding

Many deep-rooted beliefs, customs, practices, superstitions, food taboos and ignorance join hands to cause malnutrition.

Most families frown at the idea that semisolid should be introduced early enough, when the infant is about 4 to 6 month old. They wish to wait until the infant begins to approach the first birthday for a date from the priest to start semisolid at a ceremony called "annaparasana". By this time the infant is perhaps already anemic and having some degree of protein energy malnutrition.

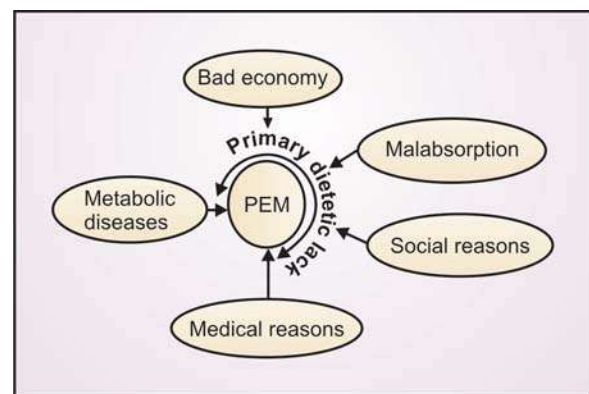

Fig. 13.1: Ecology of malnutrition

Decline in the good practice of breastfeeding just because ignorant mothers wish to ape the sophisticated city women, leading to the widespread practice of artificial feeding, providing diluted and, most probably, dirty formula, is today contributing considerably to malnutrition.

Great reliance on milk, which may be awfully diluted, continues to dominate the scene even in educated and well-to-do families. We have seen mothers complaining that their toddlers are failing to thrive. On enquiry, it is revealed that these children have been almost entirely on milk and virtually no solids.

Most parents would withhold all foods other than diluted milk once the child has some illness like diarrhea, measles, or abdominal pain—a practice which is bound to deteriorate child's nutritional status.

Yet another limiting factor in adequate nutrition is the belief that certain foods are not given to the baby just because they are said to be “hot” or “cold” in nature.

Medical Reasons

Infections and disorders such as diarrhea, malaria or measles may prove major contributory factors in development of malnutrition, indirectly or directly. Besides the deliberate restriction of food by the parents, child's intake may be reduced due to reduced appetite. At the same time, there may result more catabolism to produce the heat energy lost during a febrile episode.

Intestinal parasitic infestations may either deprive the host of nutrients or lead to malnutrition by reducing appetite, causing diarrhea, or by producing absorptive defect.

Large Families

Nutritional status is adversely affected by the large size of the family. It has been convincingly demonstrated that malnutrition is much higher among children of birth order fourth and higher than in the first three children of a sibship. When there are too many children, the family has to do with whatever food it can manage. The brunt of the suffering falls on the preschool children and the mother.

Closely-spaced Families

There is evidence that when pregnancies occur rapidly, perhaps every year, or every other year, incidence of malnutrition is much higher. Ideally, there should be at least 3-year gap between the two pregnancies.

Working Mother

It is a common observation that a higher proportion of the mothers of malnourished children are daily laborers who find little time to take care of child's feeding and rearing. More often than not, “mothering” is done by an elder sibling.

Bad Start

A low birthweight infant starts life with a handicap. He is difficult to feed and is vulnerable to infections. Born usually to malnourished mothers, such infants have high mortality. The survivors have poor growth as compared to normal ones.

Secondary Malnutrition

The causes are such diseases as intestinal malabsorption (say celiac disease, tropical sprue, cystic fibrosis, etc.) tuberculosis, intestinal parasitic infestations, and diabetes, galactosemia and other metabolic disorders. Mismanagement of diarrhea with starvation therapy or hypocaloric diet (still a common practice in developing countries) is an important cause of malnutrition.

ASSESSMENT OF NUTRITIONAL STATUS

Though frank cases of kwashiorkor and marasmus cause little difficulty in their identification, assessment of nutritional status may be rather difficult, especially in borderline nutritional disturbances such as mild-moderate malnutrition.

Dietary History

The assessment must begin with the dietary history. Details about intake of cereals, vegetables, pulses, fruits, eggs, meat, etc. and thereby average daily consumption of proteins and calories should be obtained. A rough idea about the adequacy of vitamins and minerals in the diet should also be formed.

Clinical Signs

Deficiency signs such as hair changes, anemia, xerosis, cheilosis, angular stomatitis, rachitic rosary, bleeding spongy gums, dental caries, etc. should be actively looked for.

The observations on the deficiency signs should, however, be interpreted very cautiously. As for instance, phrynoderma (toad skin), though traditionally thought to be due to vitamin A deficiency, may also be a feature of scurvy and deficiency of linoleic acid.

Anthropometry

Anthropometry is a very valuable index for evaluation of nutritional status.

Age-dependent Indices

Weight for age is by far the simplest, the most widely used and the most reliable index, provided that it is recorded correctly and is related to the correct age of the individual. Also, what is more important is the serial record of child's weight periodically on a *growth chart*.

Height for age is of no use for detecting early PEM. Its value lies in detecting chronic malnutrition and stunting.

Age-independent Indices

Since, it is often difficult to find true age of the child in the underprivileged and ignorant sections of society, the following truly or relatively *age-independent indices of nutritional status* are recommended.

Weight for height, which is only partially age-independent, is calculated as follows:

Percentage weight for height =

$$\frac{\text{Actual weight}}{\text{Expected weight for actual height}} \times 100$$

Nabarrows's Thinners chart, based on weight for height, is recommended by Save the Children Fund. The child is made to stand against the chart which bears the expected weight for height. The child's head touches the upper red zone in the presence of severe PEM.

Midarm circumference is measured midway between the point of the shoulder (acromian) and olecranon process. For all practical purposes, the maximum circumference of the upper arm measured when the left arm is hanging by the side of the body would do. Between second and fifth years, it is said to remain constant between 16.25 and 16.75 cm. This is because of replacements of the baby fat with muscle tissue. Any child in this age group with a circumference < 12.5 cm of the reference international standard is to be considered suffering from severe malnutrition and between 12.5 cm and 13.5 cm from mild-to-moderate malnutrition.

For exact figures regarding mid-arm circumference at various ages see Table 3.1.

Midarm muscle circumference is calculated by the following formula:

$$\text{MAMC} = \text{MAC} - \pi \times \text{triceps skin fold thickness.}$$

Chest/head circumference ratio < 1 after 1-2 years points to PEM.

Triceps skin fold thickness is measured by a standard caliper (Lange, Herpenden or Best). Tanner chart gives the normal values at different ages. On an average it exceeds 10 mm in 1 to 6 years age group. A measurement between 6 to 10 mm points to mild-moderate malnutrition and under 6 mm to severe malnutrition.

Mid-upper-arm/height ratio of less than 0.29 indicates gross malnutrition, the normal being 0.32 to 0.33.

QUAC-stick method is a simple, easy, inexpensive and yet reliable method of detecting early malnutrition of acute onset. QUAC-stick is an abbreviation for Quacker arm circumference measuring stick. The instrument consists of a stick graduated with figures for midarm circumference in relation to height. For this test, maximum left arm circumference (the arm hanging by the side of the body) is recorded. Then, the child is made to stand in front of the Quac-stick. From the graduations in the stick, his nutritional status in terms of 50, 60, 70 or 80% of the standard can be easily read (Fig. 13.2).

Shakir tape method is a simple and age-independent tool for assessing malnutrition. This special tape has colored zones: red, yellow and green, corresponding to less than 12.5 cm (wasted), 12.5 to 13.5 cm (borderline) and over 13.5 cm (normal) midarm circumference.

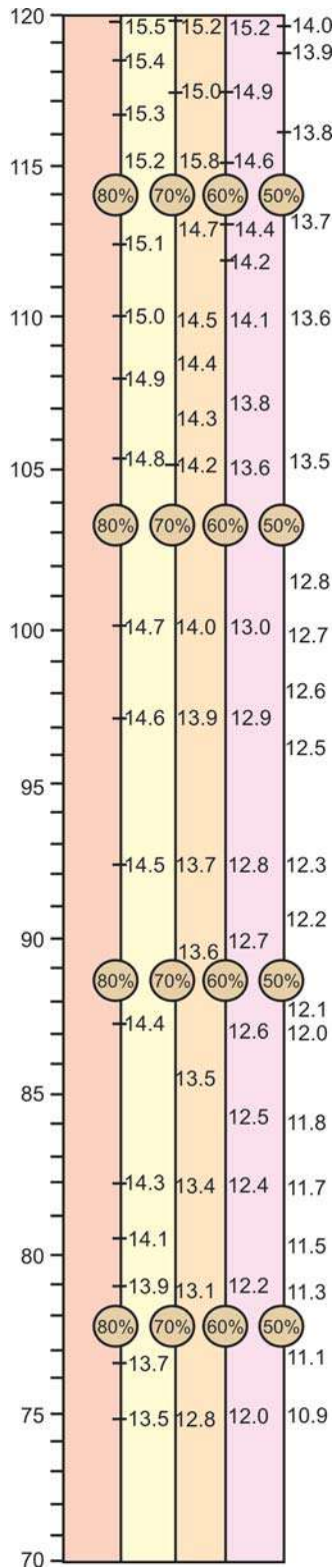

Fig. 13.2: QUAC-stick method—Q = Quacker, L = Upper, A = Arm, C = Circumference

Bangle method, another method not needing age and useful in preschool children, consists in slipping a bangle with a diameter of 4 cm up the forearm. An attempt is made to move it over to the upper arm. In case it can slip over the elbow, malnutrition is present. The method, though simple and easy, is not quite reliable.

Quetlet index based on relationship between weight and height is expressed as $\text{weight (kg)} \times 100 / \text{height (cm)}^2$. Normal value varies between 0.14 to 0.16. In gross malnutrition, it is less than 0.14. It is quite reliable. It is similar to BMI, except that here we take height in centimeters rather than meters.

Dugdale index too is based on relationship between weight and height. It is expressed as:

$$\frac{\text{Weight (kg)}}{\text{Height (cm)}} \times 1.6$$

Normal value varies between 0.88 to 0.97. An index of less than 0.79 suggests malnutrition.

Rao's weight/height ratio is expressed as:

$$\frac{\text{Weight (kg)}}{\text{Height}^2 \text{ (cm)}} \times 100$$

Normal value is above 0.15

Investigations

Laboratory investigations include hemoglobin, serum proteins, blood levels of nutrients like vitamins, iron, etc. and amino acid level (Box 13.1) in blood and urine.

The real value of biochemical tests is to detect subclinical malnutrition that could not be revealed by anthropometry. How far these tests are of concrete value in practice remains to be convincingly substantiated.

Radiology may reveal some retardation of bone age, osteoporosis or classical signs of scurvy or rickets. Some workers have described transverse lines of arrested growth at the growing ends of long bones months prior to onset of frank PEM.

Associated Disorders

While assessing the nutritional status, one must look for signs pertaining to malabsorption, intestinal parasitic infestations, tuberculosis, etc.

Box 13.1: Serum amino acid patterns in PEM

Distortion of amino acid pattern is measured by comparing concentrations of two groups of amino acids using per chromatography as shown:

$$\text{Ratio} = \frac{\text{Glycine+serine+glutamin+taurine}}{\text{Valine+leucine+isoleucine+methionine}}$$

Mean ratio in normal children is 1.5. In subclinical malnutrition, it is between 2.0 and 4.0. In kwashiorkor, it is above 3.5.

Urinary urea/creatinine ratio: This ratio can be expressed by any of two formulas:

$$1. \text{ U/C} = \frac{\text{Mg- urea- nitrogen ml}}{\text{Mg- creatinine- nitrogen ml}^{-1}}$$

$$2. \text{ U/C} = \frac{\text{Mg- urea- nitrogen ml}^{-1}}{\text{Mg- creatinine ml}}$$

The reduced ratio is a measure of average protein intake rather than the exact nutritional status.

Urinary hydroxyproline index: The formula for calculating hydroxyproline index (HOP) is as follows:

$$\text{HOP index} = \frac{\text{Memol hydroxyproline ml}^{-1}}{\text{Memolcreatinine ml - body weight}}$$

Normal value varies between 2.0 and 5.0 an index of less than 2.0 reflects growth retardation.

Urinary hydroxyproline creatinine ratio: It is supposed to be better than the HOP index. Its main flaw is that it varies considerably with age. Standard values for different ages are available.

Urinary creatinine-height index (CHI): It is the ratio between the creatinine excreted by the subject in 24 hours and the daily creatinine output of the average normal child of the same height:

CHI =

$$\frac{\text{24 - hour urine creatinine}}{\text{24 - hour urine creatinine for a normal child of the same height}}$$

In kwashiorkor and marasmic kwashiorkor, value varies between 0.25 and 0.75. In nutritional marasmus, it ranges between 0.33 to 0.85. Normal children and those having fully recovered from malnutrition show an index of around unity.

3-Methylhistidine excretion 24-hour urinary excretion of 3-methylhistidine/kg body weight in malnourished children is reduced to around 33% of that of normal children. With beginning of nutritional rehabilitation, values speedily return to normal.

Salivary protein, salivary ferritin and free alpha-amino nitrogen in leukocyte are reduced in malnutrition.

Vital Statistics

For evaluation of the nutritional status of a community, the above measures should be supported by vital statistics such as infant mortality, neonatal mortality, perinatal mortality, stillbirth rate, 1 to 4 years mortality and life expectancy as also the ecological background.

PROTEIN-ENERGY MALNUTRITION (PEM): A SPECTRUM

The term, protein-energy malnutrition, refers to a class of clinical conditions that may result from varying degree of protein lack and energy (calorie) inadequacy. This nomenclature replaces the relatively older designation, i.e. protein-calorie malnutrition, on the recommendation of the World Health Organization (WHO) and Food and Agriculture Organization (FAO).

The term has been adopted because it is now widely agreed that the major limiting factors in the diet of children, particularly in the countries of the Third World, are energy and proteins, usually more of the former. Deficiency of proteins is usually not primary and isolated. Almost always it appears to be due to poor intake of food (energy) as such. There is evidence that if child's energy is taken care of, it will be difficult for him to have significant protein deficiency. Else, if his energy consumption is poor, whatever proteins he takes are likely to be consumed to provide energy rather than to build the tissues.

Among the various factors that influence the clinical manifestations of protein-energy malnutrition (PEM) figure magnitude of deprivation, its duration, relative inadequacy of different principles of food and the accompanying infection or some other disease.

Broadly speaking, two major clinical syndromes, *kwashiorkor* and *nutritional marasmus*, are widely recognized. Kwashiorkor is said to result from gross deficiency of proteins though energy deficiency is also present. Nutritional marasmus, on the other hand, results from gross deficiency of energy though protein deficiency also accompanies. Thus, it is clear that there is deficiency of both, proteins and energy, in both the states. The predominance of the deficiency determines whether it is going to be kwashiorkor or nutritional marasmus.

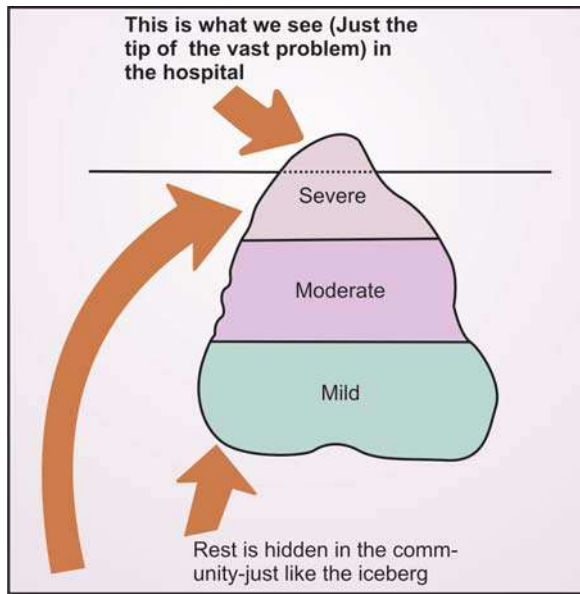

Fig. 13.3: Malnutrition (tip of “iceberg”)

Many malnourished children show overlap in the clinical picture, demonstrating features of both the deficiency states at a time. It is often quite appropriate to label them as *marasmic-kwashiorkor*.

But, the aforesaid severe form of PEM constitute only a tip of the widespread problem of malnutrition (Fig. 13.3). A vast majority of the children suffering from mild to moderate forms of it remain hidden in the community for one or another reason. The two types of this subclinical malnutrition are: nutritional dwarfing (stunting) and pre-kwashiorkor.

All these form of PEM, in actuality, constitute a continuous spectrum of the manifestations of malnutrition. Growth failure and poor tissue repair (due to protein lack) and energy shortage (due to calorie deficiency) are common to all the forms.

EVOLUTION OF PEM

Dietary Hypothesis

According to the widely-accepted *dietetic hypothesis*. Kwashiorkor is predominantly a protein deficiency and marasmus an energy deficiency. Of course, both proteins and energy lack-exist in both the syndromes. This hypothesis has a good deal of support from studies in the laboratory animals as well as work on human beings.

Adaptation Hypothesis

The noted nutritionist, Gopalan, has claimed that dietary background of children suffering from kwashiorkor and marasmus may well be the same. According to his postulation, the so-called *adaptation hypothesis*, marasmus is an extreme degree of adaptation to prolonged inadequacy of proteins and energy in the diet. Kwashiorkor is a stage of adaptation failure or dysadaptation which may follow two situations. First: continued prolongation of the stress of malnutrition. Second: sudden precipitation or aggravation by a fulminant infection such as measles, pertussis, bronchopneumonia or acute diarrheal episode.

Gopalan feels that whereas nutritional marasmus may be the result of extreme degree of adaptation and the kwashiorkor the result of dysadaptation, relatively mild effect of adaptation may be responsible for nutritional dwarfing. Since, according to Gopalan's hypothesis, kwashiorkor follows occurrence of dysadaptation in a marasmic child, most of the cases are likely to show features of both, i.e. marasmic kwashiorkor.

Aflatoxin Contamination Hypothesis

More recently, it has been postulated that *aflatoxin contamination* of food may well be an important factor in the causation of kwashiorkor.

Golden's Hypothesis of Free Radicals

According to Golden's *hypothesis of free radical damage*, kwashiorkor results from overproduction of free radicals (because of infection, toxins, iron, etc) and breakdown of protective mechanism (provided by vitamin A and E, carotene, zinc, copper, selenium, manganese, etc).

Jelliffe's Hypothesis of Interactions and Sequelae

According to Jelliffe, kwashiorkor is an intrinsically nutritional disorder with vulnerability to other factors, some identified and some unidentified. It is the cumulative result of a *mixture of interactions and sequelae* of dietary imbalances and/or deficiency, infections, para-sitosis, emotional trauma from maternal deprivation due to abrupt weaning from breasts, toxins like aflatoxin or ochratoxin.

PEM AND DISTURBANCES OF METABOLISM

Many like to designate PEM as a “metabolic disorder”. This is quite understandable if we recall that the disease is characterized by profound disturbances of water and electrolytes, minerals, protein, fat, carbohydrate and energy metabolism.

Water, Electrolytes and Minerals

Total body water Total body water is increased in PEM, irrespective whether it is of kwashiorkor or marasmic type. A positive correlation exists between the magnitude of rise in body water and the extent of weight loss. Thus, lowest values are found in kwashiorkor and the highest in marasmus.

Whether the alteration is secondary to increased cellular mass which constitutes the active protoplasm of the body and reduction in the adipose tissue is not clearly understood.

A noteworthy point is that despite increased body water, a malnourished child is thirsty. This paradoxical observation is ascribed to the defective thirst mechanism in PEM.

Potassium There is a definite reduction in the total body potassium by as much as 25%. Though all organs are depleted of potassium, the musculature suffers the most followed by the brain. Potassium depletion is more marked in cases of PEM with diarrheal disease. In kwashiorkor, it is significant even in the absence of diarrhea. Whether potassium depletion results from gastrointestinal losses through the gut or from defects in specific enzymes (that have a role in carbohydrate metabolism), or both, is not clear. Potassium deficiency may be existing despite absence of any clinical manifestations of dehydration and/or hypokalemia.

A very high frequency of pyelonephritis and acute renal failure is encountered in cases of severe malnutrition whose potassium depletion has not been attended to. Of course, the contributory role of concomitant dehydration and infection cannot be denied.

Sodium Unlike potassium depletion, sodium is retained by the body. Sodium retention is primarily extracellular though muscle, skin, brain and viscera, too, are affected.

Intracellular sodium retention and potassium deficit may change the function of important enzymes

in carbohydrate metabolism and oxidative phosphorylation.

Magnesium Magnesium depletion in PEM is now well established. This deficiency may cause grave disturbances, including neurologic signs such as twitching, tremors and convulsions.

Phosphorus Both forms of phosphorus (organic as well as inorganic) are decreased in the muscles of malnourished children. Adequate nutritional correction leads to increase in both the forms. The exact significance of this observation, particularly from a clinical angle, remains obscure.

Calcium Calcium depletion is a common feature of PEM, more so when the assessment is based on blood levels. However, clinical evidence of tetany is infrequent.

Iron Iron deficiency anemia is a common feature of PEM. It is, however, complicated by other deficiencies involving folic acid, vitamin B₁₂ vitamin E and probably some other vitamins.

Copper Low levels of copper in serum, hair and liver of subjects suffering from PEM have been documented. There may also be low levels of ceruloplasmin which plays the role of a “link” in copper and iron metabolism.

Chromium Chromium deficiency has been blamed for the impaired glucose tolerance in malnourished children. There is evidence that it may contribute to poor growth of the child during the earlier stage of nutritional rehabilitation. Chromium therapy may accelerate growth in marasmic infants.

Zinc Low serum as well as muscle and liver zinc values exist in PEM. Zinc deficiency may play an important role in the etiology of the *syndrome of growth retardation with short stature, hypogonadism, hepatosplenomegaly and anemia* in boys. The supplementation of zinc to such boys results in a dramatic improvement. Sometime, within three weeks of initiating treatment, significant gain in weight and acceleration of sexual maturity are achieved. Zinc deficiency is also associated with infantile tremor syndrome and diarrheal disease.

Protein and Amino Acids

Total serum protein level is always reduced, principally due to hypoalbuminemia which is remarkable in kwashiorkor. The level of beta-globulins is also reduced. Alpha and gamma-globulin level is variable in absolute terms; it is invariably high in relation to other serum protein fractions.

There is a remarkable reduction in the total body protein. Its turnover, unlike that of albumin, may be high rather than low.

Significant reduction in plasma amino acids occurs in kwashiorkor. Valine, leucine, isoleucine and tyrosine are the ones most affected. There is a rise in amino acid recycling in kwashiorkor. This mechanism, together with low urea synthesis, increased ammonia and urea nitrogen utilization for protein synthesis, contributes to increased nitrogen economy in protein deficiency.

Lipids

There is a reduction in fat absorption from the gut. Also, there is increase in fecal fat (steatorrhea) even when diet is free from fat. Free bile acids are increased whereas there is a decrease in the concentration of conjugated bile acids. The latter are supposed to be essential for dissolution of lipids in the lumen of the gut and their eventual absorption.

The transport of fat from liver to tissues as low density lipoproteins is considerably reduced though transport from gut to liver is not much altered.

Various factors that may contribute to the fatty liver of kwashiorkor are increased fat transport from tissues to liver, reduced synthesis of beta-lipoproteins, increased liver lipogenesis, and probably reduced level of essential fatty acids.

Carbohydrates and Energy

Hypoglycemia occurs frequently and may prove fatal in a proportion of cases. Glucose absorption is impaired due to deficiency of disaccharidase enzymes in the intestinal mucosa. Handling of intravenously administered glucose and galactose is abnormal. Circulating insulin levels are low. The levels fail to respond to stimulation with glucose or arginine.

Disaccharide intolerance is a common transient phenomenon. Hence, it is advisable to avoid large loads of lactose containing foodstuffs during early part of management of PEM.

Levels of growth hormone are high but of somatostatin low. Basal metabolic rate (BMR) is reduced. Thyroid function, too, is low.

PEM AND INFECTION

The interaction between infection and nutrition has been a subject of countless studies over the past few

decades. Today it is widely recognized that there is a definite association between malnutrition and infection.

Malnutrition is the most common immunodeficiency in pediatric practice and breaks down the host resistance in by and large all segments (Figs 13.4 and 13.5). The most consistent abnormality detected in various studies has been the impairment in cell-mediated immunity (CMI). That explains why bacterial infections, which count on CMI for host's defence against them, are very severe in children suffering from PEM. Secondly, children with PEM are difficult to sensitize by repeated antigens. Thirdly, even the delayed hypersensitivity reactions that recall previous sensitization are also delayed.

There is evidence that iron-deficiency anemia has an adverse effect on the cellular immune response.

The underlying mechanisms include lymphopenia, reduced number of T-lymphocytes in the peripheral blood, impaired response to mitogen and antigens, decreased lymphokine production and serum inhibition.

It has been demonstrated that levamisole improves the ability of lymphocytes to proliferate *in*

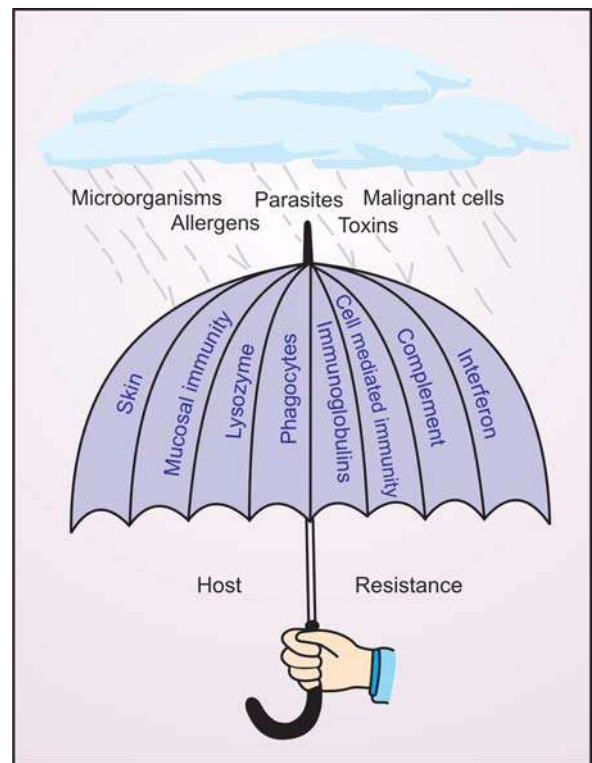

Fig. 13.4: Host resistance in a healthy, well-nourished child provides protection against adverse influences and insults



Fig. 13.5: Immunodeficiency secondary to malnutrition. Note the widespread breakdown in host resistance, involving almost

in vitro in response to phyto mitogens and increases the number of rosetting T-lymphocytes. However, the effect on lymphocyte stimulation response is less than that achieved by nutritional supplementation both at 2 and 4-week intervals after initiation of therapy. When given together with nutritional rehabilitation, levamisole administration is associated with an increase in cell-mediated response *in vivo* and *in vitro*, the change being observed earlier than a significant gain in weight. The clinical significance of these observations is not yet clear.

Interrelationship between PEM and infection is summarized in Box 13.2.

Box 13.2: Interrelationship between PEM and infection

Causes of malnutrition leading to infection

- Micronutrient deficiency: Iron, zinc, copper, selenium
- Vitamin deficiency: Vitamin A, C, E, B₆, folate
- Impaired cell-mediated immunity (CMI), phagocytic function and complement system
- Reduced cytokine production
- Reduced concentration of IgA, IgM and IgG

Cause of infection leading to malnutrition

- Reduced intake of food, especially micronutrients
- Enhanced catabolic losses
- Reduced absorption of nutrients
- Metabolic inefficiency because of micronutrient deficiency

PEM AND FAMILY PLANNING

In developing countries, women (often malnourished) begin to produce children at a much younger age. They continue doing so quite frequently with poor spacing. Result: too many births. What is still more disturbing is that they continue doing so as long as they are not old enough.

This phenomenon leads to impaired nutritional status of both the mother and her babies, many of whom may be born after intrauterine growth retardation has already affected their bodies and perhaps brains. Such infants start life with a distinct disadvantage. They are also candidates for high morbidity and mortality.

Undoubtedly many of such deaths could be prevented. The biostatisticians call such deaths as excessive "reproductive wastage".

The question arises: why do women reproduce at such a high pace in developing world? The reason is simple. Unless parents can be assured that the children they have are going to survive into adulthood, they will be unwilling to consider limiting their reproductive activities. It has, therefore, been argued that nutrition and general health activities should be coordinated to provide major support for maintaining health and promoting survival of infants and children.

A strong plea is made for promoting the traditional breastfeeding with suckling done throughout the 24 hours each day. This practice is not only a safeguard against malnutrition but it also has an effect on ovulation and birth spacing.

PEM AND ENDOCRINAL STATUS

Cortisol Contrary to earlier studies, now it has been convincingly shown that serum cortisol levels in gross PEM are high, suggesting hyperfunction of the adrenal cortex. Such factors as infection and hypoglycemia are said to contribute to this observation.

High cortisol levels mediate the following useful functions:

- Augmentation of lipolysis
 - Enhancement of muscle protein catabolism
 - Promotion of liver protein synthesis
- Somatomedins** Serum levels of insulin like growth factor (IGF-1 and 2) are low due to one or more of the following factors:
- Low protein and/or energy supply in diet
 - Lack of essential amino acids
 - Low insulin/cortisol ratio

Low somatomedins levels mediate the useful function of reducing energy and oxygen utilization by retarding growth.

Insulin Impaired serum insulin levels are found in kwashiorkor and marasmic kwashiorkor but not in marasmus due to:

- High energy low protein ratio in diet
- Low body potassium
- Deficient insulinotropic factors and insulin transport by the damaged pancreas.

Growth hormone Growth hormone levels are high in PEM, reflecting increased secretion rather than impaired clearance. The causative factors include:

- Low somatomedin levels
- Hypoalbuminemia and low amino acid levels
- Low serum tyrosine level.

The useful functions mediated by this observation include:

- Facilitation of the process of lipolysis
- Boosting of glucogenesis
- Decrease in catabolism of albumin.

Glucagon Glucagon levels are high whereas insulin levels are low in PEM, leading to low insulin/glucagon ratio. The following useful functions may be mediated.

- Reduction in glucose uptake by muscles and adipose tissue, sparing heart and brain
- Increased muscle protein catabolism
- Increased lipolysis and fatty acid supply to peripheral tissues.

Thyroxine Contrary to earlier observations, thyroid hormone production is either normal or high in kwashiorkor but normal or low in marasmus.

PEM AND DIARRHEA

Diarrhea is a common accompaniment of the clinical picture of overt PEM. Its prevalence is 5 to 7 times more and its severity 3 to 4 times greater in malnourished children as compared to normal children. In the not-so-distant past, recurrent diarrhea in malnourished children was generally ascribed to superimposed infections and infestations. No doubt, malnourished patients are particularly susceptible to infection because of the impaired cellular immunity which is an important adverse sequel of malnutrition *per se*.

It was earlier suggested that, besides bacterial and parasitic contamination of the gut, gastrointestinal candidiasis may contribute to the common occurrence of diarrhea in malnutrition. The investigations from Indo-nesia and Australia lent support to this hypothesis.

Recently, it has been convincingly demonstrated that PEM may *per se* cause striking morphological as well as functional damage to the small intestinal mucosa, leading to malabsorption. Transitory secondary disaccharidase deficiency, causing lactose intolerance and osmotic diarrhea, has also been observed in significant proportion of the cases. The earlier reports suggesting existence of some monosaccharide malabsorption have now been substantiated. Moreover, it is to be noted that iron deficiency is a common occurrence in PEM. Since there is evidence that iron deficiency may itself contribute to an exudative enteropathy in childhood, the role of such anemia in etiology of diarrhea of malnutrition seems to be convincingly established.

A recent study has documented significant decline in histamine augmented maximum acid output as also presence of chronic gastritis and gastric mucosal atrophy in per oral gastric biopsies in marasmic children.

Finally, there is evidence that PEM may give rise to pancreatic atrophy and decreased enzyme secretion. Digestive disturbance and diarrhea may result.

Thus, it becomes obvious that diarrhea in malnutrition is of multifactorial etiology. An absolutely clear picture of the whole problem may emerge in the near future. The information as it stands today, however, does highlight some salient aspects which definitely have bearing on the line of management.

PEM AND CARDIAC FUNCTION

Gross malnutrition is known to considerably reduce the weight and the size of the heart. This is ascribed to atrophy of the cardiac muscle.

On the functional front, cardiac output is reduced in keeping with the severity of weight loss. There is prolongation of the systemic recirculation time, appearance time, bradycardia and reduced peripheral blood flow. Congestive cardiac failure may occur. ECG shows nonspecific changes. Radiology shows

reduction in heart size. Not only does malnutrition *per se* affect cardiac function, but other factors such as accompanying severe anemia, reduced oxygen consumption and hypothyroid state too contribute to it.

PEM AND RENAL FUNCTION

PEM causes reversible impairment of renal function as manifested by:

- Reduction in glomerular filtration and renal plasma flow, especially when there is accompany gastroenteritis.
- Aminoaciduria, phosphaturia and inefficient excretion of an acid load from disturbed tubular function
- Urine is acidic due to increased excretion of hydrogen ions to conserve potassium.

PEM AND DRUG DISPOSITION

It is now well established that nutritional status of a child has significant effect on the bioprocesses involved in disposition of various drugs in the body. As a result, bioavailability of the drug(s) for therapeutic purposes is influenced, often warranting alteration in dose and frequency of administration.

The exact observations concerning different drugs in various studies are, however, far from uniform.

CLASSIFICATION OF PEM

I. Syndromal Classification

- Kwashiorkor
- Nutritional marasmus
- Marasmic kwashiorkor
- Prekwashiorkor
- Nutritional dwarfing (Stunting)

II. Gomez Classification

According to this classification, PEM is graded with reference to the weight for age as percentage of the expected weight (Harvard standard):

- First degree : Weight between 90 and 75% of expected for age
- Second degree : Weight between 75 and 60% of expected for age
- Third degree : Weight below 60% of expected.

III. Wellcome or International Classification

Weight between 80 and 60% of expected for age:
with edema : kwashiorkor
without edema : undernutrition

Weight below 60% of expected
with edema : marasmic kwashiorkor
without edema : nutritional marasmus

IV. Classification of the Indian Academy of Pediatrics (IAP)

- First degree : Weight between 80 and 70% of expected for age
- Second degree : Weight between 70 and 60% of expected for age
- Third degree : Weight between 60 and 50% of expected for age
- Fourth degree : Weight below 50% of expected
- In case the child has demonstrable pitting edema, the letter "K" is placed in front of the evaluated grade.

V. Jelliffe Classification

- First degree : Weight between 90 and 80% of expected
- Second degree : Weight between 80 and 70% of expected
- Third degree : Weight between 70 and 60% of expected
- Fourth degree : Weight below 60% of expected

VI. McLaren Classification

- Mild : Weight between 90 and 80% of expected
- Moderate : Weight between 80 and 70% of expected
- Severe : Weight below 70% of expected

All these classifications recommended Harvard standard as the reference standard (now obsolete). CDC reference standards are the current recommendation.

VII. Waterlow Classification

- Acute (wasted but not stunted) : Weight for height low, height for age normal
- Acute/chronic (wasted and stunted) : Weight for height low, height for age low
- Nutritional dwarfing (stunted but not wasted) : Weight for height normal height for age low

Application of both the indices (as in Waterlow classification) is, therefore of greater value than application of one.

VIII. WHO Classification (Table 13.1)

Table 13.1: WHO classification of PEM (Fig. 13.6)

Criteria	Moderate PEM	Severe PEM
Symmetrical edema	No	Yes
Weight for height (Index of wasting)	70-79% of expected (Wasting)	< 70% of expected (Severe wasting)
Height for age (Index of stunting)	85-89% of expected (Stunting)	< 85% of expected (Severe stunting)

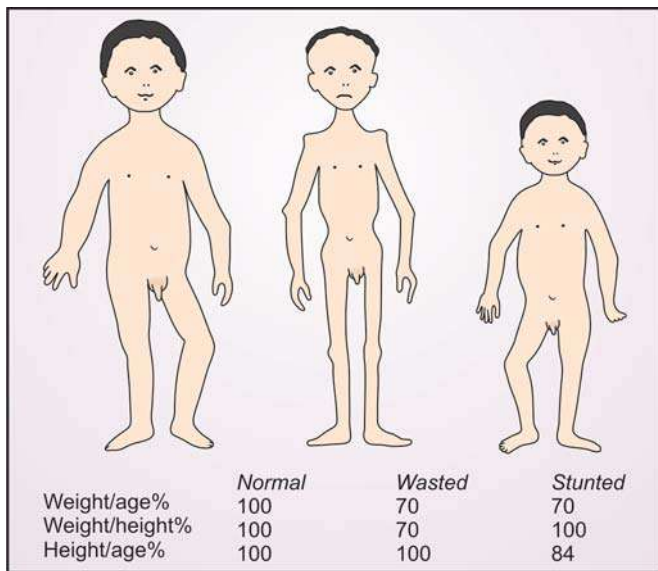

Fig. 13.6: Normal wasted and stunted children. Weight-for-age is low in both wasted child and the stunted child. But weight for height is not affected in the stunted child

IX. Arnold Classification

It is based on midarm circumference (MAC):
 Mild to moderate MAC between 12.5 - 13.5 cm
 Severe MAC under 12.5 cm

X. Classification Based on Skinfold Thickness

Mild : 80-90 % of expected for age (8-9 mm)
 Moderate : 60-80 % of expected for age (6-8 mm)
 Severe : Under 60 % of expected for age (> 6 mm)

Note:

1. Weight for height

$$= \frac{\text{Actual weight}}{\text{Weight of normal child of the same age}} \times 100$$

Height for age

$$= \frac{\text{Actual height}}{\text{Height of normal child of the same age}} \times 100$$

2. Reference norms for comparison are CDC standards

SPECIAL FEATURES OF CLINICAL SYNDROMES

Kwashiorkor

The earliest description of kwashiorkor in the English medical literature was made in 1933 by Cicely Williams, a noted British physician. That time she did not really know how to christen the disease. Later, in 1935, she introduced the term "kwashiorkor", the local name for the disease in Ghana. It was said to mean the "red boy", because of the characteristic pigmentary changes. In 1950, the term was more aptly interpreted to apply to the mystique of the disease that affected the deprived child due to the arrival of yet another.

Clinical Features

The disease is chiefly encountered in infants and children in the preschool age group. A vast majority of the cases are in 1 to 4 years age group. No age is, however, exempt. Occasionally, it may be seen in infants aged few months, in adolescents and even in adults.

A classical case of kwashiorkor is dull, apathetic and miserable, evincing hardly any interest in the surroundings. His growth is stunted and there is marked muscle wasting with some retention of subcutaneous fat (Fig. 13.7). He has pitting edema over the legs and feet and perhaps over certain other parts of the body. There may be diarrhea, skin and hair changes, anemia and vitamin deficiency signs. Liver is, as a rule, enlarged due to fatty change. Table 13.2 provides further grading of kwashiorkor.

Though this is the picture of full-blown kwashiorkor, it may be noted that only four signs growth



Fig. 13.7: Kwashiorkor, showing characteristic features

Table 13.2: Grading of kwashiorkor

Grades	Characteristics
1	Pedal edema
2	+ Puffiness of face
3	+ Edema of chest wall and back
4	+ Ascites

failure, muscle wasting with retention of some subcutaneous fat, mental apathy and hypoalbuminemic edema (not of cardiac, renal or hepatic origin) taken together are sufficient by themselves to label a case as “kwashiorkor”. The remaining elements may individually or collectively accompany the essential features, depending on the severity of the disease, dietary pattern and regional variations.

Biochemical Changes

These are striking. Serum proteins are always low, the maximum reduction being that of the albumin fraction; the globulins may often be found relatively elevated.

Anemia is usually moderate to severe and may be of variable morphology though iron-deficiency is a common denominator in most cases.

Low serum enzymes (esterase, amylase, lipase, choline-sterase and alkaline phosphatase), serum cholesterol, glucose, urea, certain vitamins, potassium and magnesium occur. The activity of pancreatic enzymes is considerably reduced. Total body potassium is diminished.

Imbalance of plasma amino acids and amines aciduria are common findings. Impaired cellular immunity is present.

Diagnosis

Dietetic enquiry reveals deficient intake of both proteins and calories, the protein lack being more predominant, over a prolonged period. Occurrence of an added stress like measles, whooping cough, diarrhea or bronchopneumonia often precipitates the overt picture, leading to development of pitting edema.

Diagnostic criteria may be divided into two major subdivisions: essential and nonessential.

A. Essential Features (Minimal Diagnostic Criteria)

- i Growth retardation as evidenced by low weight and low height,
- ii. Muscle wasting with retention of some subcutaneous fat,
- iii. Psychomotor change as evidenced by mental apathy in the form of silent listless inertness, lack of interest in the surroundings,
- iv. Hypoalbuminemic pitting edema, at least over the pretibial region. Serum albumin should be less than 2.5 g/dl and cardiac, hepatic, renal and angioneurotic causes of edema should be ruled out. These essential features are to be considered the minimal diagnostic criteria for kwashiorkor.

B. Nonessential Features

These are variable features and may or may not be present in each and every case.

- i. *Hair changes* in the form of hypochromotrichia (light-colored hair), sparseness (areas of alopecia), change in texture (coarseness, silkiness) and easy pluckability. Alternate bands of light and dark color have earned the name “flag sign”



Fig. 13.8: Classical hair changes in kwashiorkor



Fig. 13.9: Kwashiorkor, showing characteristic hair changes, mental apathy and moon facies with periorbital edema

which signifies periods of inadequate, adequate and inadequate nutrition over a prolonged period. This fascinating sign is only occasionally encountered (Figs 13.8 and 13.9).

- ii. *Skin changes* include light-colored skin but the most classical dermatosis consists of areas of hyperpigmentation intervened by areas of raw red skin caused by shedding of the superficial skin flakes. This has been called *flaky-paint dermatosis*. Another similarly characteristic skin lesions of kwashiorkor is *crazy-pavement dermatosis*. Reticular pigmentation, mosaic dermatosis and pellagra-like lesions over the exposed parts (usually dorsal surfaces) may also be encountered (Figs 13.10 to 13.14).

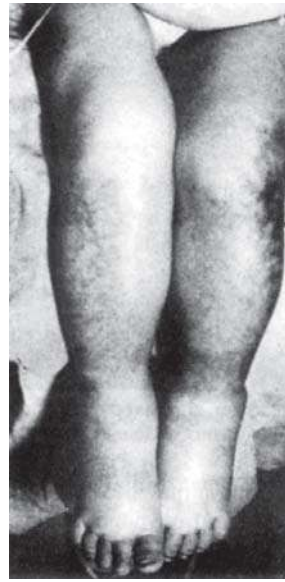

Fig. 13.10: Kwashiorkor showing massive edema over feet and legs also mosaic dermatosis. This is the same child as in Figure 13.9



Fig. 13.11: Kwashiorkor in a toddler. Note the classical flaky-pain dermatosis and massive edema. Absence of hair changes reflects acute nature of the ailment

Besides the aforesaid dermatosis, kwashiorkor children may suffer from indolent sores and ulcers besides superadded skin infections like pyodermas and scabies.

- iii. *Gastrointestinal manifestations* include diarrhea, vomiting and anorexia. In spite of edema, the child may develop dehydration. Diarrhea may be due to: (a) superadded intestinal infections and parasitic infestations like *Giardia lamblia*, (b) effect of malnutrition *per se* on intestinal mucosa, causing reversible villous atrophy and malabsorption, inhibition of the activity of the enzyme disaccharidase (mainly lactase), causing disaccharide (mainly lactose) intolerance and damage to the pancreas, and (c) iron-deficiency anemia which can, on its own, lead to enteropathy by damaging the intestinal epithelium. Thus, it is obvious that diarrhea in children suffering from kwashiorkor has multifactorial etiology.
- iv. *Mineral and vitamin deficiencies* are common. Anemia is usually present and is moderate to severe in intensity. It is frequently iron-deficiency type though dimorphic and even pure megaloblastic morphology may be encountered.



Fig. 13.12: Kwashiorkor in a toddler. Note the classical skin lesions and massive edema



Fig. 13.13: Typical crazy-pavement dermatosis and gross edema of kwashiorkor



Fig. 13.14: Typical flaky-paint dermatosis and gross edema of kwashiorkor

There is evidence that PEM may *per se* cause anemia. Accompanying factors such as intestinal parasitic infestations and systemic infections may also play a contributory role.

Other mineral deficiencies are those of potassium and magnesium.

Deficiency of vitamin A is frequent and may lead to serious problem of keratomalacia and irreversible blindness.

Deficiencies of vitamin B-complex, C, D and E may also complicate the picture.

- v. *Hepatomegaly*, quite often fairly remarkable (liver may touch the umbilicus), is invariably present. The consistency is usually soft, the edge rounded and the surface smooth.
- vi. *Superadded infections* (say, tuberculosis, broncho-pneumonia, enteritis, measles, pyodermas, etc.) and intestinal parasitic infestations (*L. giardia*, *Ent. histolytica*, roundworm, hookworm, threadworm, *H. nana*, etc.) are common. Infection by gram-negative organisms (usually enteritis and septicemia and occasionally urinary tract infection) are most trouble-some to manage in such patients.
- vii. *Clubbing* may be encountered in a proportion of the children with kwashiorkor as a result of the accompanying steatorrhea.
- viii. *Nonspecific ECG changes* may be found in a small proportion of the cases. A significant cardiac involvement is seldom seen.

Nutritional Marasmus

Though kwashiorkor has received far greater attention from the researchers, nutritional marasmus is encountered more frequently in several parts of the world, particularly in north India. At times, the condition is referred to as *athrepsia* or *infantile atrophy*.

Clinical Features (Figs 13.15 and 13.16)

Nutritional marasmus occurs usually in subjects less than 3 years of age; the peak incidence is seen during the first year of life. The disease may be encountered in later childhood.

A characteristic feature of the clinical picture is remarkable wasting of both muscles and subcutaneous fat. The face is wizened and shrivelled—just as in the case of a monkey. In the early stages, the child is irritable, hungry and craves for food. But, in the later stages, he may become miserable and apathetic,



Fig. 13.15: Nutritional marasmus in a 2-year-old child. Note the remarkable wasting of both muscles and subcutaneous adiposity. The child had been only on a diluted formula. The parents were waiting for “annaprasana” ceremony to initiate solids



Fig. 13.16: Nutritional marasmus showing remarkable wasting over gluteal region. This is the same marasmic child as in Figure 13.15

refusing to take anything. Edema is conspicuous by its absence. Significant hair changes, dermatosis and marked fatty liver are also absent. As in kwashiorkor, diarrhea, mineral and vitamin deficiencies,

Table 13.3: Achar's grading of nutritional marasmus

Grades	Characteristics
1	Loss of fat from axilla/groin
2	Loss of fat from abdominal wall and gluteal region
3	Loss of fat from chest wall and back (paraspinal region)
4	Loss of buccal pad of fat (which consists of fatty acids); it takes longer time to disappear

superadded infections and parasitic infestation are commonly seen.

Table 13.3 provides grading of nutritional marasmus.

Biochemical Changes

These are slight until marasmus is of very advanced degree. The reason is that the amino acids liberated from child's own tissues make possible a continuing synthesis of serum enzymes, albumin and other essential metabolites.

Anemia is mild to moderate and may be of any morphologic type though iron-deficiency anemia undoubtedly dominates the picture.

Electrolyte disturbances may occur in the presence of diarrhea and vomiting. Blood urea is usually normal and blood sugar slightly raised. Duodenal enzymes show little or no reduction.

Diagnosis

Dietetic history suggests inadequacy of both proteins and calories (carbohydrates) in child's intake in the recent past. The predominant lack is of calories. Diagnostic criteria may be essential and nonessential as outlined below:

A. Essential feature (Minimal diagnostic criteria)

1. *Growth retardation* as evidenced by marked loss of weight and subnormal height/length.
2. Gross muscle as well as subcutaneous fat wasting.
3. Absence of edema.

B. Nonessential features

1. Hair changes are usually not present;
2. Classical dermatosis of kwashiorkor is not seen. However, indolent sores and ulcers as also superadded skin infections occurs very frequently.
3. Gastrointestinal manifestations like diarrhea and vomiting occur as in kwashiorkor. A marasmic child is, however, hungry rather than anorexic

though he may develop anorexia once marasmus has advanced to extreme degree.

4. Mineral and vitamin deficiencies occur fairly commonly. Anemia is usually mild to moderate and may be of varied morphology. Potassium and magnesium deficiencies occur in patients with diarrhea and vomiting. Vitamin deficiencies occur relatively less often compared to kwashiorkor.
5. Liver is rather shrunk which is in sharp contrast to the fatty, enlarged liver of kwashiorkor.
6. Superadded infections and infestations are nearly as common as in kwashiorkor.
7. Psychomotor change is usually in the form of irritability rather than listlessness. Advanced cases may, however, become apathetic as is seen in kwashiorkor.
8. Clubbing may be seen in a proportion of marasmic children. It seems to be related to the accompanying steatorrhea.

MARASMIC KWASHIORKOR

Marasmic kwashiorkor refers to cases demonstrating a combination of features of kwashiorkor and marasmus. Presence of edema is essential for this diagnosis (Figs 13.17 and 13.18). For instance, an established case of nutritional marasmus may be mistakenly initiated on a diet consisting of lots of calories but very little proteins. Such a child is a



Fig. 13.17: Marasmic kwashiorkor



Fig. 13.18: Marasmic kwashiorkor complicated by bleeding diathesis

candidate for developing hypoproteinemia and clinical edema. Remaining features of kwashiorkor may or may not be present.

PREKWASHIORKOR

Prekwashiorkor refers to a child who has quite poor nutritional status and certain other features of kwashiorkor such as hair changes minus edema. Such a child, unless taken care of at this very stage, may develop edema and other features of full-blown kwashiorkor.

NUTRITIONAL DWARFING (STUNTING)

If PEM starts fairly early in life and goes on and on over a number of years without causing overt picture of kwashiorkor or marasmus, child's height as well as weight may be significantly low for his age. This is what has been termed *nutritional dwarfing*.

Let us illustrate it through a specific example. An apparently healthy-looking child, appearing aged 4 years, is brought to a physician for a trivial medical problem. His height is 99 cm and weight 18.5 kg. Naturally, the physician forms an impression that the nutritional status of the child, including height and weight, is good enough for the age of 4 years. Right at this stage, the mother reveals that the actual age

1 of the child is 8 years which indeed surprises the physician. The fact is that this child is quite stunted and underweight for his actual age.

Nutritional dwarfing is a common problem in developing countries but cases are not as frequently detected. It seems to be a kind of "adaptation" to poor diet (not as grave as to cause frank kwashiorkor or nutritional marasmus) over a prolonged period. These children are generally less active and less lively. They are more prone to diarrhea, pneumonia, tuberculosis or other infections prevalent in the region.

COMPLICATIONS OF PEM

These are given in Table 13.4.

Table 13.4: Serious complications of advanced PEM

Complications	Remarks
Superadded	Both overt and hidden: Septicemia, pneumonia, diarrhea, pyoderma, scabies, UTI, tuberculosis infections.
Dehydration and dyslectrolytemia	Usually complicating accompanying diarrhea, often with lactose intolerance.
Hypothermia	An unattended rectal temperature of < 35 degree Celsius may prove fatal, causing sudden infant death syndrome (SIDS)
Hypoglycemia	It contributes to poor response to nutritional therapy and carries a poor prognosis.
CCF	It is usually precipitated by excessive intake of sodium and fluid or severe anemia. Since cardiac size is invariably small in PEM, even a normal sized heart in X-ray should arouse suspicion of CCF.
Anemia	Moderate to severe anemia may result from malnutrition as such or such factors as superadded infection(s), contributing to development of CCF.
Bleeding	DIC may complicate the clinical picture.
Sudden infant death syndrome (SIDS)	Sudden death 4-7 days after admission. Usually, the cause remains unclear.

MANAGEMENT OF PEM

Domiciliary (Home) Management

A. Mild-moderate Malnutrition

Children with mild to moderate malnutrition are best managed in their own homes and kept under

surveillance so as to find out improvement or deterioration in their nutritional status. The parents of such children are educated about the inadequacy in child's intake and guided how to correct it. The stress should be on the locally available economic foods rather than on expensive tinned protein preparations which should be reserved for special situations only. The parents must be apprised of the value of carbohydrates and the rationale of giving liberal amounts of semisolids and solids. They must understand why only milk will not be enough for the growing child. There is evidence that domiciliary treatment brings about gratifying results. It also reduces the unnecessary hospital load, is much less expensive, and, in addition, takes nutritional education to the family and the community.

Ours as well as many other workers' experience indicates that malnutrition relapse only infrequently when moderate PEM is treated at home. On the contrary, incidence of recurrences in hospital-treated cases is fairly high.

The management at home has got to be supervised and monitored by weekly visits of paramedicals (say an anganwadi worker), visits to a nearby nutrition rehabilitation center or OPD of a health centre/hospital.

A prerequisite to domiciliary treatment is absence of severe infection(s), fulminant gastroenteritis and electrolyte imbalance.

Good weight gain, as judged from the growth chart, is by and large the best yardstick of adequacy of response to nutritional rehabilitation.

B. Uncomplicated Severe Acute Malnutrition (SAMN)

Though WHO has categorically recommended hospitalization in case of severe acute malnutrition (SAMN), the IAP has recently advocated home treatment for this category since it is not at present feasible to offer them hospital treatment (Box 13.3).

Management in Nutrition Rehabilitation Center (NRC)

This concept, originally started in Southern America, aims at offering nutritional rehabilitation for mild to moderate PEM as a compromise between domiciliary and hospital managements. It offers a meeting point

Box 13.3: Domiciliary (Home) Treatment of Uncomplicated Severe Acute Malnutrition (SAMN) as per the Indian Academy of Pediatrics (IAP)

Diet: Energy-dense therapeutic diet with low bulk in the initial phase which should be

- home-based (prepared/modified from the family pot; indigenous ready-to-use therapeutic foods (RUTF))
- Cost-effective, easily available and acceptable
- Fed frequently (6-8 times/24 hours)

Supplements: Micronutrient and minerals

Oral Antibiotics: Usually cotrimoxazole or ampicillin for 7 days

Deworming: Single dose

Warming Up: Hypothermia prevented by maintaining environmental temperature and covering the child well, especially during night.

Immunization: Routine

Health Education

Others: Family and community participation, nutrition counseling, household food security, etc.

between classical treatment and prevention, embracing the positive points of both hospital and home management.

Two types of NRCs are: Day care center and residential center.

Day care NRC It consists of a room for children, a kitchen, an examination room and a teaching space.

At least one good meal is provided to children. Around 20 to 40 malnourished children along with their mothers who are expected to involve themselves in various activities are taken care of. The center remains open from 8 AM to 6 PM daily.

Residential NRC This is a larger and more organized NRC with a "housemother" as the fulltime head with responsibilities that include daily work schedule of the mothers, purchase of food, issuing the correct amount of food as decided by the nutritionist, and keeping stock and maintenance of cleanliness of the center. The supervisory staff is part time and includes a doctor, a medical assistant/nurse, a home economist/nutritionist, and an agriculture teacher/extension worker. The center is attached to a health center or the pediatric department of a teaching hospital, or an under-5 clinic. The criteria for admission to the NRC are:

- Children especially at risk
- Children who fail to gain weight over a period of 3 months

- Children who do not catch up in growth after serious illness (measles, whooping cough, diarrhea)
- Failure to breastfeeding
- Mothers and children who find it difficult to cope with their problems in spite of the health teaching they receive at the under-5-clinic
- Twins and triplets.

The stress in the NRC is on nutrition and health education, household budget teaching, homecraft teaching and actual feeding, using locally available foodstuffs and local methods of cooking and preparation.

The successful rehabilitation at the NRC must be followed up at home so that the knowledge acquired during stay at the center continues to be applied at home.

Hospital Management

Complicated severe acute malnutrition (SAMN) needs to be managed in hospital in three phases:

I. Resuscitation phase (admission to 6-24 or even 48 hours): Here resuscitation (stabilization) of the seriously sick child with complications is achieved through

- rehydration by employing WHO-recommended special rehydration solution for malnutrition (ReSoMal) which provides high glucose and low sodium and has a low osmolarity (300 mmol/L) compared to 311 in standard WHO ORS. Alternatively, IV half-strength Darrow, half-strength Ringer lactate or even half normal saline with 5% dextrose may be used. See also Chapter 16 (Fluid, Electrolyte and Acid-base Balance ...)
- thermoregulation by keeping the child warm ,
- treatment of shock by IV fluids
- treatment of severe anemia by blood transfusion, and
- treatment of superimposed infection(s) (both overt and strongly suspected) by broad-spectrum antibiotics

II. Acute (Nutritional correction) phase (2nd to 7th day): It comprises actual nutritional correction, particularly with emphasis on such components as beginning of feeding, energy-dense feeding, stimulation, and transfer to home-based diet (BEST).

1 Beginning of Feeding

It should preferably be with milk-based diet, starting with low volume and then gradually building up the quantity and frequency. In many cases, it may become necessary to initiate dietary therapy with tube feeding. As soon as the child begins oral acceptance, he should be fed orally.

Calculation of Diet The nutritional correction, the cornerstone of treatment, is carried by providing high protein and high energy diet. A daily intake of 100 kcal/kg/day of expected weight (150-200 kcal/kg/day of actual weight) and 3 g/kg of proteins calculated with reference to the actual weight should be achieved in very first week. This target is reached slowly, beginning with just 100 kcal/kg/day at the start. This is important for the much-needed catch-up growth. It is advisable to provide at least 10 percent of total calories from proteins of higher biological value. The choice of foodstuffs should be based on local resources. It is good to feed small amounts of food at more frequent intervals.

Transient lactose intolerance, causing persistent watery diarrhea, may cause difficulties in initial management. In such situations, one may use one of the lactose-free milks, soyabean milk or a vegetable-protein mixture. Subjects fed on soya-based preparations are better supplemented with zinc, 1 mg/kg/day. Zinc deficiency is as such also common in severe PEM. Zinc supplementation quickly improves the dermatosis as well. Highly concentrated milk with mashed banana and/or cereal syrup makes an excellent alternative to lactose-free preparations which are either expensive or poorly tolerated, often inducing vomiting. Such a mixture should contain 25% milk and 75% banana and/or cereals. Addition of sugar and vegetable oil (high-energy milk formula) further improves its taste and nutritional value.

Potassium supplements: As a rule, each and every child with kwashiorkor and that of nutritional marasmus with diarrhea must receive oral potassium 5 mEq/kg/day (1 g = 14 mEq) as potassium chloride solution.

Magnesium supplements: It is helpful to give magnesium sulfate, 0.5 to 1.5 ml/day (0.3 ml/kg/day with a maximum of 2 ml) intramuscularly in 2 divided doses during the first one week or two. Thereafter, magnesium supplements should come

from natural sources like milk, groundnut, peas and grains.

Treatment of anemia and micronutrient deficiencies: The associated anemia and vitamin deficiencies should be treated. However, it is a good policy to give supplements of medicinal zinc, especially to patients who are fed with soya-based preparations. Since zinc-supplemented malnourished children are likely to develop plasma copper deficiency, enough copper intake in diet should be ensured. Bleeding diathesis is an indication for vitamin K (IM) and/or platelet transfusion.

Energy-dense Feeding

After initial feeding, the child shows signs of recovery with return of appetite. This is the time to further build up his diet, employing energy-dense foods such as a mixture of cereals, pulses, jaggery and oil (preferably coconut oil).

Stimulation

Holistic approach, tender loving and emotional support contribute to recovery and catch-up growth in weight.

Transfer to Home-based Diet

The child should be gradually shifted to the home-based diet i.e diet that is easily available, acceptable, affordable by the family.

III. Rehabilitation phase (7th day to 2-6 weeks): After dietary correction spread over a week, the child accepts more and more food to make up for the deficiency. He should be encouraged to eat at libitum.

Results of Nutritional Rehabilitation

- Resumption of alertness and activity, manifested as "first smile", followed by return of appetite within first few days are good signs of recovery.
- Weight gain, after edema has disappeared, is 10 to 15 g/kg/day which is 5 times that of normal child of same height and 10 times that of normal child of same age.
- Some infants and children with marasmus may develop edema following some correction in their nutrition. The so-called "refeeding edema" results

from hyperinsulinemia causing decrease in sodium excretion. It may also follow nutritional rehabilitation with a diet that is predominant in calories (energy) with relative inadequacy of proteins

- Disappearance of hepatomegaly and enteropathy and rise in serum albumin, though steady, are somewhat slow.
- In 1 to 3 months period, the patient attains normal weight for height and can be considered as “clinically recovered”.

Discharge

Ideally, the child should be discharged from the hospital when he attains normal weight for height. It is, however, difficult to keep him in the hospital for so long because of the pressure on hospital beds. It has been suggested that discharge may be made when the child has achieved a weight that is 85% of the normal weight for height. This takes about 2 to 4 weeks.

The hospital stay should be utilized to educate the mother about the value of high protein and high energy diet of the “family type” so that she knows how to achieve “consolidation of cure” at home. Complete recovery usually takes another 2 to 4 months after the child is back home.

Poor Response to Nutritional Rehabilitation

Primary Failure is indicated by failure of

- Resumption of appetite by 4th day
- Beginning of loss of edema by 4th day, and its disappearance by 10th day
- Weight gain (a minimum of 5 g/kg/day) by 10th day

Secondary Failure is indicated by failure to gain weight over 5 g/kg/day for 3 successive days during rehabilitation phase.

There are quite a few factors that may be responsible for poor response to nutritional rehabilitation (Table 13.5)

PHENOMENA ENCOUNTERED DURING NUTRITIONAL REHABILITATION

Favorable

1. Resumption of alertness as shown by a smile and interaction with mother
2. Initiation of weight gain

Table 13.5: Factors contributing to poor response to nutritional rehabilitation

- Feeding Inadequacy: Faulty, inadequate
- Failure to adequately treat the accompanying infection(s) (pneumonia, diarrhea, UTI, AOM, intestinal parasitosis, malaria, tuberculosis, HIV)
- Failure to properly treat accompanying dehydration and dyselectrolytemia
- Failure to attend to accompanying deficiencies (say anemia)
- Poor Facilities: Untrained and poorly motivated staff, inadequate environment
- Serious underlying diseases: Malabsorption, immunodeficiency, inborn errors of metabolism, malignancy.

3. Disappearance of edema (by 7-10 posttherapy day)
4. Disappearance of enteropathy and hepatomegaly
5. Elevation of serum protein
6. Attainment of normal weight and height in 1-3 months (“clinical recovery”)

Unfavorable

1. *Pseudotumor Cerebri*

Overenergetic nutritional correction in malnourished infants may be accompanied by a transient rise of intra-cranial tension. The phenomenon is benign and self-limiting.

2. *Nutritional Recovery Syndrome (Gomez Syndrome)*

The term refers to an interesting sequelae of events seen in children who are being treated with very high quantity of proteins during the course of rehabilitation from gross malnutrition. The syndrome is characterized by increasing hepatomegaly, abdominal distention, ascites, prominent thoraco-abdominal venous network, hypertrichosis, parotid swelling, gynecomastia and eosinophilia. In some instances, splenomegaly also occurs. Though the syndrome was initially described in kwashiorkor from Africa, we have recorded its occurrence in both kwashiorkor and marasmus in India.

Etiopathogenesis of this syndrome remains speculative. Its development may well be related to endocrinal disturbances. That in PEM the function of the pituitary and its target glands is set at a lower ebb is well known. This response of the pituitary to the state of poor dietary intake appears to be an

1 adaptive mechanism that permits survival of the patient by reducing body activity and metabolic rate, and by retarding growth. During nutritional rehabilitation, the greater utilization of the hormone by the body stimulates the pituitary to produce its trophic hormones. This results in a response by the target glands. Thus, it appears that the nutritional recovery syndrome is caused by an increase in estrogen level and by a variety of trophic hormones produced by the recovering pituitary gland.

3. Encephalitis-like Syndrome

About one-fifth children with kwashiorkor become drowsy within 3 to 4 days after initiation of dietary therapy. Most often, the condition is self-limiting. Occasionally, it may be accompanied by progressive unconsciousness with fatal outcome. Even more rarely, a transient syndrome marked by coarse tremors, parkinsonian rigidity, bradykinesia and myoclonus (Kahn syndrome) may appear 6 to several days after starting the dietary rehabilitation. Sometimes, tremors (the so-called “kwashi-shakes”) may occur during the recovery phase and may take even months to resolve.

These encephalitis-like states are considered to be the result of far too much of proteins in the diet.

4. Rickets

During nutritional recovery, as a result of rapid growth, vitamin D, calcium and phosphate consumption may fall short of the body needs, causing rickets. In some children, the pre-existing but hidden rickets become manifest following restoration of bone growth during nutritional rehabilitation.

5. Anemia/Micronutrient Deficiency

In addition to the pre-existing anemia as a part of malnutrition, the child may manifest further worsening in hemoglobin status if iron and folic acid supplements are not provided during nutritional rehabilitation. Likewise, deficiencies of other micronutrients may too become manifest.

PROGNOSIS IN PEM

With good hospital care, mortality rate in gross PEM has today considerably fallen. Against the alarmingly high figures of 20 to 50% in the older series, the recent

reports indicate 5 to 20% mortality. In our experience, it is around 5-10%, kwashiorkor children dying more often than those suffering from nutritional marasmus.

Bad prognostic signs include severe dehydration, hypoglycemia, hypothermia, CCF, superimposed infections, xerophthalmia, bleeding diathesis, hepatic dysfunction, seizures, significant change in sensorium and cachexia (extreme weight loss).

The causes of mortality include dehydration and electrolyte imbalance (dysselectrolytemia), hypoglycemia, hypothermia, fulminant systemic infections and congestive cardiac failure. In our experience, dehydration and electrolyte imbalance due to diarrheal disease and fulminant systemic infections are the chief killers of malnourished children. Congestive cardiac failure, though uncommon, carries a very bad prognosis. In some cases hypoglycemia and hypothermia may prove fatal.

LONG-TERM SEQUELAE OF PEM

Growth Retardation

Infants who suffer from significant malnutrition fairly early in life and over a prolonged period develop a permanent, irreversible stunting of growth.

Mental Impairment

Now a sort of consensus seems to have emerged concluding that IUGR and malnutrition in the first year of life, if severe enough to retard physical growth and to warrant hospitalization, may cause retardation in mental performance, eventually leading to low intelligence and impaired learning skills.

Malnutrition and Liver

It is no longer believed that PEM causes cirrhosis in the long run. The concept is based on longitudinal follow-up studies of children suffering from severe PEM and the observation that incidence of cirrhosis in Africa, the home of kwashiorkor, is fairly low.

PREVENTION OF MALNUTRITION

WHO has described malnutrition as a “global problem”, having adverse effects on the survival, health performance and progress of population groups. The effects are of the highest order in the developing countries.

Prevention at Family Level

The most significant in the preventive measures at family level is what is called “nutrition education”. Nutrition education consists of:

- i. *Good antenatal care* so that mother’s own nutrition remains up to the mark and she does not develop malnutrition and anemia. This will be of much help in reducing the incidence of intrauterine growth retardation and LBW, the predecessors of malnourished children in very many instances.
- ii. *Encouragement to the mothers to breastfeed the infants* for as long as they can. Even if the mother is not in a position to breastfeed the infant for some reason, it is of advantage to express her milk and feed it to him. Of course, she must take good diet and adequate amounts of fluids to maintain her lactation. In case of prolonged breastfeeding, it is to be confirmed that the lactation performance of the mother is adequate. Else, adequate supplementation of feeding becomes imperative.
- iii. At the age of 6 months, the infant should start receiving *complementary feeding*, in addition to breastfeeding. The supplements should be combination of cereals, protein-rich foods and fruits such as mashed banana.
- iv. The practice of shifting to artificial feeding in the form of bottle feeding with diluted cow milk or tinned milk should be discouraged, particularly in the poor in whose families it is virtually impossible to prevent occurrence of contamination of the bottle and the formula.

Prevention at Community Level

Here again nutritional education is of vital importance. Its delivery may be either through mass media such as radio, television, posters, documentary, films, etc. or imparting knowledge to the mothers at group meetings or at the doorstep of the family by the health auxiliary.

Secondly, surveys to detect cases of mild to moderate malnutrition, using preferably age-independent criteria, should be conducted. Such children may be kept under surveillance and, if required, given nutritional supplements.

The supplementary feeding programs in India include applied nutrition program, midday meal program for school children, special nutritional program, vitamin A prophylaxis program, anemia

prophylaxis program, integrated child development services (ICDS), food for work program, etc. The principal beneficiaries of such programs are the nutritionally vulnerable preschoolers, school-going children and pregnant and lactating mothers. Ample evidence is now available to support the contention that adequate supplementation through the feeding programs results in improvement of nutritional status of the target population, provided that operational efficiency is ensured.

Prevention at National Level

This consists of measures to improve food production, control price-rise, make available cheap supplementary foods, fortify and enrich foods, prevent adulteration and irradiate certain foods such as wheat, potato and onion. Also, nutrition education and containment of population explosion are of paramount importance.

Prevention at World Level

Efforts to intensify various international food programs like those of WHO, FAO, UNICEF, CARE, OXFAM, SIDO, DANIDA, Indo-Dutch, etc.

NATIONAL NUTRITION PROGRAMS

Applied Nutrition Program

Launched in 1963 with the assistance of UNICEF, WHO and FAO, this program aims at improving the nutritional status of the mothers (both expectant and nursing) as well as the infants and children. The cornerstone of the program is health education. The community is educated through such personnel as rural health workers, teachers, doctors, youth and women leaders to produce more of protective foods (say, fish, eggs, milk, vegetables and fruits) and to promote their consumption by the mothers and children.

The program covers 1,375 community development blocks, serving 1.7 million people.

Ever since it was first launched, the program has not proved of as considerable value as was expected.

Special Nutrition Program (SNP)

This supplementary feeding program under the Ministry of Social and Welfare (Center) has been in

1 operation ever since 1970. Its target population is preschool children (6 months to 6 years) and expectant nursing mothers. In the beginning, the program was restricted to urban slums and tribal areas but later extended to selected rural and chronically famine-struck areas.

Beneficiaries are provided 200 kcal and 8 to 10 g proteins per child per day upto one year of age and 300 kcal and 10 to 12 g proteins per day per child between ages 1 to 6 years. Beneficiary women receive daily 500 kcal and 25 g protein. The supplementary food is provided for 300 days in a year. "On the spot" provision of cooked food approach has been found to be in the greater interest of the child rather than the "take-home" ready-to-eat preparation approach.

This program has attained a coverage of several millions (Table 13.6).

Midday Meal Program

Also called School Lunch Program, it was first organized in 1957 in Tamil Nadu (then Madras State). Since 1962, it has been in operation in several parts of India and is at present estimated as covering around 16 million children.

The two major objectives of the program are: first, improvement in the nutritional status of the children since they are provided supplementary foods and are also given nutrition education; second, to provide a kind of incentive for enrollment and retention of children in the schools, thereby enhancing the literacy rate.

Based on the source of food material required to support the program, it has two components. First is the CARE-assisted program which covers 11 million beneficiaries in 15 States/Union Territories. In this program, ready-to-eat foods, say "muruku", are provided for about 200 days in a year to the school children. Second program operates entirely at the expense of the State governments.

Since 1982, Tamil Nadu is financing a new *Nutritious Meal Program* in over 21,000 balwadies and 32,000 primary schools for children between 2 to 10 years. As many as 28 recipes, such as rice, dal, oil, and vegetables, are formulated for use. Each meal claims to supply 400 kcal and 10 g proteins for preschool child and 500 kcal and 12 g protein for the older child. Yet, the cost of the one meal remains as low as 45 paise.

Table 13.6: Factors contributing to failure of response to nutritional therapy

Factor	Check
As a Group	
High mortality rate	<p><i>Within 24 hours:</i> Consider untreated or delayed hypoglycemia, hypothermia, septicemia, severe anemia or incorrect rehydration fluid or volume.</p> <p><i>Within 72 hours:</i> Check whether refeeding with too high a volume/feed or wrong formulation.</p> <p><i>At night:</i> Consider hypothermia from insufficient covers or missing night feeds.</p> <p><i>Transition to catchup formulation:</i> Consider a sudden or far too rapid a change.</p>
As an Individual	
Inadequate feeding	<p>Does the child indeed receive the night feeds?</p> <p>Are the target energy and protein intakes achieved?</p> <p>Is the child fed frequently and offered unlimited amounts?</p> <p>Is the nursing staff caring, motivated, loving and patient?</p> <p>Is feed preparation correct?</p> <p>If giving a catchup formulation, ensure that it is suitably modified to provide at least 100 kcal/100 g.</p>
Specific nutrient deficiencies	<p>Adequacy of multivitamin composition, shelf-life.</p> <p>Preparation of electrolyte/mineral solution and whether correctly prescribed and administered.</p>
Untreated infection(s)	<p>For such hidden infections as UTI, AOM, giardiasis and tuberculosis</p> <ul style="list-style-type: none"> • Reexamine carefully • Repeat urine microscopy for pus cells • Examine stool repeatedly • Take chest X-ray
HIV/AIDS	Test for lactose intolerance and manage it on usual lines.
Psychological problems	Abnormal behavior, e.g. rocking and other stereotyped movements, rumination and attention seeking; treatment is social love and attention.

Likewise, Andhra Pradesh has also come up with an ambitious school meal program which incorporates such recipes as bun, milk, rice and pulses (Table 13.7).

Table 13.7: Hyderabad protein-energy rich mixture for home treatment of PEM

Roasted whole wheat	40 g
Roasted Bengal gram	16 g
Roasted groundnut	10 g
Jaggery	20 g
Total	86 g, providing 330 kcal and 11.3 g proteins

Balwadi Nutrition Program

This program, first started in 1970, is under the overall charge of Social and Welfare Department of the Union Government. The budget allocation at present is over 17 million.

The supplement food given to the child provides 300 kcal and 10 g proteins per child.

Anemia Control Program

Iron and folic acid tablets are distributed to the pregnant women and young children through the maternal and child health centers in the towns and primary health centers in the rural areas.

At present nearly 28 million women and children are benefiting from the program.

Nutritional Blindness Prevention Program

This program has been in operation since 1970 and consists in giving every six months a dose of 200,000 international units of vitamin A (one teaspoonful) to children in endemic areas. The practice is continued till the child crosses 5 years of age.

In areas where this program is operative, incidence of blindness due to vitamin A deficiency has dramatically fallen.

Iodine Deficiency Control Program (Goiter Control Program)

This national program, in operation since 1962, aims at controlling endemic goiter (thyroid swelling, visible over the front of the neck) through supply of iodized common salt to the population in the endemic areas. Fortification of the salt is done in such a way that it does not affect the acceptability of the stuff. For more details, see Chapter 11.

Integrated Child Development Services (ICDS) Scheme

This scheme aims at providing a package of services with the major objective of (a) improvement of health and nutritional status of children below 6 years and ensuring their all round development, (b) reduction of death and disease, and (c) assisting the mother to look after health and wellbeing of child by providing nutrition and health education.

The target beneficiaries of the Scheme are children under 6 years and women between 15 to 44 years. The stress is on women who are expectant or nursing. For details see Ch (Community Pediatrics)

NATIONAL NUTRITION POLICY

Acknowledging that malnutrition, especially in infants and children, in India is rampant, a National Nutrition Policy was adopted in 1993.

Aims and Objectives

1. To identify vulnerable groups requiring immediate intervention.
2. To identify key areas for action in the field of food production, supply, information, nutrition education, rural development, health care, monitoring and surveillance.

National Plan of Action on Nutrition (NPAN)

1. Reduction in moderate and severe malnutrition among preschool children by half
2. Reduction in incidence of low birthweight infants to less than 10%
3. Reduction in chronic undernutrition and stunted growth in children
4. Elimination of blindness due to vitamin A deficiency
5. Reduction in iron-deficiency anemia in pregnant women by 25%
6. Universal iodization of salt for reduction of iodine deficiency disorders (IDD) to 10%
7. Giving due emphasis to geriatric nutrition
8. Production of 250 million tonnes of food grains
9. Improving household food security through poverty alleviation programs
10. Promoting appropriate diets and healthy lifestyle.

Short-term Measures

1. Nutrition intervention for specially vulnerable groups in the form of
 - expanding the safety net, particularly ICDS program
 - appropriate behavioral changes among mothers
 - reaching the adolescent girls
 - ensuring better coverage of expectant women for the better health and reducing the incidence of low birthweight infants
2. Fortification of essential foods with iron and iodine
3. Popularization of low-cost nutritious foods
4. Control of micronutrient deficiencies amongst vulnerable groups.

Long-term Measures

1. Food security
2. Improvement of dietary pattern through production and demonstration
3. Policies for affecting income transfers by:
 - i. improving the purchasing power, and
 - ii. streamlining the public distribution system
4. Land reforms
5. Health and family welfare
6. Basic health and nutrition knowledge
7. Prevention of food adulteration
8. Nutrition surveillance
9. Monitoring of nutrition program
10. Research into various aspects of nutrition
11. Equal remuneration for men and women
12. Better communication strategies

13. Minimum wage administration
14. Community participation.

FURTHER READING

Articles/Chapters

1. Ashworth A, Jackson A, Uwuy R. Focusing on malnutrition management to improve child survival in India. *Indian Pediatr* 2007;44:413.
2. Bhan MK, Bhandari N, Bahl R. Management of the severely malnourished child: perspectives from developing countries. *BMJ* 2003;326:146.
3. Bhatnagar S, Lodha R, Choudhury P. IAP Guidelines 2006 on hospital-based management of severely malnourished children (adapted from the WHO guidelines). *Indian Pediatr* 2007;44:443.
4. Gupta P, Shah D, Sachdev HPS, Kapil U. National workshop on "Development of guidelines for effective home-based care and treatment of children suffering from severe acute malnutrition". *Indian Pediatr* 2006;43:125.
5. Gupte S. Nutritional recovery syndrome. *N Engl J Med* 1972;291:501.
6. Gupte S. Nutritional rehabilitation. *Indian J Pediatr* 1983;50:97.
7. Jelliffe DB, Jelliffe EEP: Causation of kwashiorkor: towards a multifactorial consensus. *Pediatrics* 1992;4:502.
8. WHO Guidelines for the inpatient treatment of severely malnourished children (Part II). *Nutrisearch* 2000;7:3.

Books/Monographs

1. Alleyne GAO, Hay RW, Picou DI, Stanfield JP, Whitehead RJ. *Protein-energy Malnutrition*. London: Edward Arnold 1989.
2. Gupte S. *Textbook of Pediatric Nutrition*. New Delhi: Peepee 2006.
3. International Institute for Population Sciences (IIPS)/ Macro International. *National Family Health Survey (NFHS)-3(2005-06)*. India, Vol. 2, Mumbai:11PS2007.
4. Sachdev HPS, Choudhury P. *Nutrition in Children: Developing Country Concerns*. New Delhi: BI 1994.



Vitamin Deficiencies

Suraj Gupte

CLASSIFICATION

These organic compounds, though needed in only small amounts, are essential for maintenance of normal health and must be provided from external sources, i.e. diet. Two broad categories are known:

- i. Water-soluble: Vitamins B-complex and C
- ii. Fat-soluble: vitamins A, D, E and K.

Water-soluble vitamins are not stored in body in any appreciable quantity. Their excessive consumption causes no particular toxicity, the surplus being excreted.

On the contrary, fat-soluble vitamins are stored in liver and their excessive consumption may cause toxicity.

Vitamin deficiencies may occur as such or in combination with other nutritional problems such as protein-energy malnutrition.

VITAMIN A DEFICIENCY (VAD)

Vitamin A, a fat-soluble alcohol, is derived primarily from a plant pigment, *beta-carotene*, which plays a vital role in the photochemical basis of vision. Conversion of carotene to vitamin A occurs in the intestinal wall and its absorption into the lymphatic system is facilitated by bile. It is concerned with the maintenance of epithelial tissue in the body, especially that of eye, skin and mucous membrane.

Deficiency of vitamin A, *xerophthalmia*, a leading cause of blindness among the underprivileged, continues to be a problem of public health magnitude in the developing world.

Of the 10 million children suffering every year from xerophthalmia, 5 million belong to Asia. One-fourth of them are eventually blinded. Half a million go blind in India alone every year.

Etiology

Vitamin A deficiency usually occurs in association with malnutrition and chronic intestinal disorders such as malabsorption states, chronic diarrheal disease, pancreatic disease like cystic fibrosis of pancreas (fibrocystic disease or mucoviscidosis) and hepatic insufficiency. In these situations, vitamin A absorption or metabolism is disturbed.

Diarrhea is a risk factor for vitamin A deficiency; *vice versa* also is true. Severe measles too is a risk factor for vitamin A deficiency.

Prevalence

The precise incidence of xerophthalmia in the pediatric population defies evaluation. In general, 3 to 10% of the infants and children in the Third World suffer from it. In north India, surveys conducted by the Child Health Study Group reveal incidences of 6 to 7% in preschoolers and 8.1% in school-going children. The incidence in hospitalized children in Kolkata is 9.8%. The prevalence in south India is even higher.

Clinical Features (Figs 14.1 to 14.7)

These may be considered under the two subheadings, ocular and extraocular.

Ocular The earliest manifestation, *night blindness* or poor dark adaptation, is due to insufficient formation of the visual purple, *rhodopsin*. Often, the mother of the infant observes that he takes considerable time to adjust to dim light or darkness.

Xerosis of conjunctiva is usually the first sign that can be seen on examination. The conjunctiva becomes dry, lustreless, wrinkled and dirty-brown in color. These changes are most obvious in the interpalpebral



Fig. 14.1: Bitot's spot. Note the position of the lesion and its shape. The foamy deposit lies on top of a patch of pigmented conjunctiva

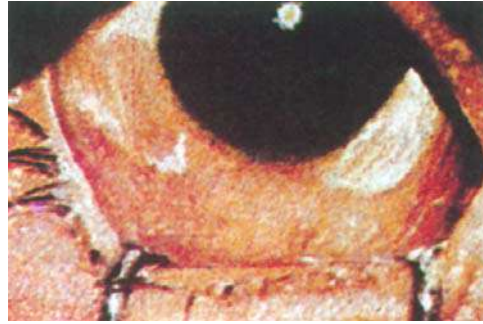

Fig. 14.5: Xerophthalmia. Bitot's spots and wrinkled, dry conjunctiva in a 3-year-old boy with night-blindness

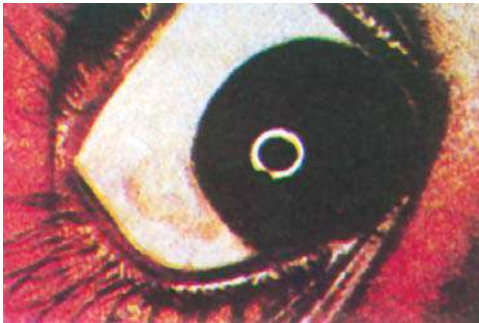

Fig. 14.2: Xerophthalmia. Bitot's spot with localized xerosis and pigmentation in a 4-year-old boy

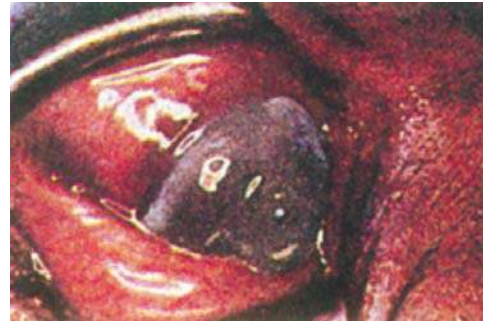

Fig. 14.6: Xerophthalmia. Keratomalacia in a 3-year-old girl. Note the grayish bulging, jelly-like cornea showing large perforation containing iris and lens



Fig. 14.3: Xerophthalmia. Xerosis, wrinkling and pigmentation of conjunctiva in a 2-year-old girl. Note the dull cornea and blurred flash reflex



Fig. 14.7: Xerophthalmia. Phthisis bulbi as a result of vitamin A deficiency in a 3-year-old girl who has gone blind

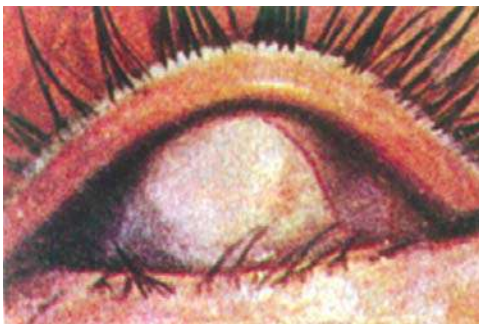

Fig. 14.4: Xerophthalmia. Bulging staphyloma in a 4-year-old girl

bulbar conjunctiva. In advanced cases, significantly evident involvement of conjunctiva over the lower lid and lower fornix may be present (Table 14.1).

Conjunctival xerosis may lead to formation of the so-called Bitot spot which consists of an almost triangular area, usually about the lateral aspect of the limbus, covered by fine, white, foamy or greasy substance. It is basically a heaped-up dry mass of conjunctival epithelium. The appearance is like grains on a chalky, pasty foam. It is noteworthy that Bitot spots are generally seen in both the eyes and are present more frequently to the lateral than the medial of the limbus.

Table 14.1: WHO classification of xerophthalmia

XN	Night blindness
XIA	Conjunctival xerosis
XIB	Bitot spot
X2	Corneal xerosis
X3A	Corneal ulceration/keratomalacia <1/3rd corneal surface
X3B	Corneal ulceration/keratomalacia >1/3rd corneal surface
XS	Corneal scar
XF	Xerophthalmic fundi (white retinal lesions)

Keratomalacia is the advanced stage of xerophthalmia. It consists of softening, necrosis and ulceration of the cornea. Unlike the preceding stage of corneal xerosis, keratomalacia is irreversible, except for the possible replacement of the grossly damaged cornea by a transplant. Once cornea gets involved, photophobia accompanies the clinical profile.

With the onset of keratomalacia, cornea melts into a dead-white to dirty-yellow structure; invasion by an infection (which is quite usual) further aggravates the situation. If corneal perforation occurs (which again is quite frequent), herniation of the lens and vitreous may result (Fig. 14.8).

Eventually, *panophthalmitis* leads to almost total destruction of not just the cornea but that of the whole eyeball. Irreversible blindness (which was entirely preventable) is the final outcome, the eye ending up as a shrunken globe.



Fig. 14.8: Xerophthalmic corneal ulcer ending up as a corneal opacity/scar (XS), a key index of vitamin A deficiency in the community

During the course of destruction of the globe, retina does not lag behind in suffering. On fundoscopy, it reveals small white spots and granules, the so-called *fundus ophthalmicus*.

Extraocular The extraocular manifestation of vitamin A deficiency include:

- Dry, scaly skin, especially over the outer aspect of the limbs, called follicular hyperkeratosis, toad skin or phrynoderma,
- Hypertrophy or even atrophy of tongue,
- Increased susceptibility to infections due to squamous metaplasia of respiratory, urinary and vaginal tract epithelium as a result of impaired immune response (both specific and nonspecific); renal and vesical calculus may occur more often in such subjects,
- Growth failure and
- Pseudotumor cerebri.

Diagnosis

High index of suspicion from the clinical picture is the most important diagnostic measure. Support may be obtained from the dark adaptation test.

Objective tests based on vital staining of xerotic conjunctiva (Rose Bengal, Lissamine, Kajal or other maskera) or conjunctival impression cytology (CIC) may supplement clinical diagnosis of xerophthalmia.

Determination of plasma or liver retinol (vitamin A) level is helpful. The normal values are 50 to 100 IU in infants and 100 to 300 IU in grown-up children.

Vitamin A absorption test may be carried out by giving 0.2 ml/kg of cod liver oil by mouth. Blood samples are obtained before its administration and thereafter at 3,5,7,9 and 12 hours. Afterwards, a curve is plotted from the vitamin A values obtained on these samples. A flat curve indicates defective absorption.

Treatment

The currently recommended WHO/UNICEF schedule for treatment of xerophthalmia is summarized in Table 14.2. It needs to be clearly noted that it is now advisable to use an oily preparation for oral and a water-miscible preparation for injection.

It is noteworthy that abuse of vitamin A may cause toxicity (hypervitaminosis A). Manifestations may include irritability, lassitude, alopecia, anorexia, fever, benign raised intracranial pressure (pseudotumor cerebri) and hard tender swellings over the bones.

Table 14.2: WHO/UNICEF treatment schedule of xerophthalmia

Children 1 to 6 years and above	
Immediately on diagnosis	200,000 IU vitamin A (O)
The following day	200,000 IU vitamin A(O)
Four weeks later	200,000 IU vitamin A(O)
Children under 1 year and under 8 kg weight at any age	
Half the doses as indicated for children 1 to 6 years and above	
For night blindness or Bitot Spot	
Treat with a daily dose of	10,000 IU of vitamin A(O) for 2 weeks

Note: If there is a persistent vomiting or profuse diarrhea, an intramuscular injection of 100,000 IU of water-miscible vitamin A (but not an oil-based preparation) may be substituted for the first dose.

Steroids may be of help if used early enough in these cases. Almost all cases recover fully without any sequelae. Rarely, deaths are, however, reported.

Prevention

An intake of at least 1500 IU/day in infants and children less than 4 years and 5000 IU/day in grown-up children should be ensured. Just milk meets this requirement in infants. Older children need leafy vegetables and red palm oil in addition to milk.

According to the *National Vitamin A Prophylaxis Program*, all children in the age group 6 months to 6 years in the target areas should receive 2,000,000 IU of vitamin A (in an oily base) orally every six months. By the 5th birthday, the child is expected to receive 9 oral doses of vitamin A. The agent is supplied as a syrup of 100,000 units of vitamin A per ml.

For preventive purposes, use of P-carotene-rich foods, dark green leafy vegetables (DGLV), say mustard (sarson), spinach (palak), fenugreek (methi), amaranth (chaulai), drumstick (sahjan), yellow vegetables (carrot), yellow fruits (mango, orange, papaya) and vitamin A-rich foods, say fish, liver, fresh liver oil, dairy products and edible oils, should be encouraged. "Vision by vegetables" is a good slogan.

Dark green leafy vegetables are an inexpensive and superb source of P-carotene (precursor of vitamin A). Just 40 g of GLV cooked with 2 to 3 g of oil provide 1200 µg of β-carotene which is the recommended daily allowance (RDA) as per WHO. Even in malnourished children, absorption of b-carotene is about 70 percent. Children are able to eat enough (GLV) from a single traditional meal to meet their vitamin A requirement.

Fortification of commonly-eaten foods with vitamin A can be an effective prophylactic measure in a population.

Finally, adequate and timely treatment of PEM, intestinal parasitosis and diarrheal disease, especially with supplementation of the intake with dark-green leafy vegetables and edible oil, goes a long way in preventing xerophthalmia.

The pregnant and lactating mothers should get enough of retinol or carotene in their diets.

Hypervitaminosis A manifests in the form of pseudotumor cerebri, and hyperostosis (especially involving tibia). "Gulf syndrome" refers to hypervitaminosis A plus D secondary to excessive consumption of fish oil pearls marketed by Gulf countries.

THIAMINE DEFICIENCY

Thiamine (vitamin B₁), a water-soluble vitamin, is an essential coenzyme for metabolism of carbohydrates, especially in oxidative decarboxylation of pyruvic acid to acetyl-coenzyme A and other alpha-ketoacids in the Krebs' cycle. It is believed to play vital role in the nutrition of heart and peripheral nerves.

It is freely distributed in animal and vegetable products such as liver, egg, yolk, pork, legumes, yeast, pericarp and germ of cereals, autolysed yeast (marmite), and milk. Polishing the rice considerably destroys its thiamine content.

Etiology

Thiamine deficiency occurs either because of poor intake in the diet, malabsorption states, or prolonged illness.

Clinical Features

Thiamine deficiency leads to the disease, beriberi. It occurs usually in infants (*wet beriberi*) though older infants and children may also suffer from its chronic form (*dry beriberi*). *Meningitic form* is also known.

The earliest symptoms, occurring in early infancy (especially if the mother is providing thiamine-deficient breast milk), include restlessness, bouts of excessive crying (as if the infant is having an abdominal colic), vomiting, abdominal distention, flatulence, constipation and insomnia.

In the acute cardiac form (wet beriberi), the infant may develop congestive cardiac failure in the form of tachycardia, gallop rhythm, dyspnea, cyanosis, hepatomegaly, cardiomegaly, edema and pulmonary edema. The possibility of thiamine deficiency should always be considered in endemic areas in subjects presenting with intractable congestive cardiac failure.

In the chronic neurologic form (dry beriberi), the manifestations may include anorexia, weight loss, weakness, diarrhea, constipation and edema. The child is usually drowsy and apathetic. Ataxia is common. There may be peripheral neuritis and various palsies, including hoarseness due to vocal cord paralysis, and nystagmus. Deep tendon reflexes are usually absent.

In the meningitic form The clinical picture is dominated by bulging anterior fontanel, dilated pupils, head retraction and coma. Convulsions may occur, leading to a mistaken diagnosis of encephalitis or meningitis. CSF reveals no abnormality.

In addition to all this, thiamine dependency has been incriminated in the etiology of:

- i. anomalies of branched chain ketoacid decarboxylase system, e.g. maple syrup urine disease, and
- ii. syndrome of optic atrophy, intermittent ataxia, lactic acidosis and hyperalaninemia due to pyruvate decarboxylase deficiency.

Diagnosis

Differential diagnosis may have to be made from pyloric stenosis and other high obstruction in the presence of troublesome vomiting. Endomyocardial fibroelastosis, congenital heart disease and glycogen storage disease involving the heart (Pompe disease) may be considered in the presence of CCF. Chronic neurologic form would require differentiation from lead poisoning. Meningitic form may be confused with meningitis or encephalitis, A normal CSF may prove most helpful in such a situation.

Diagnosis of beriberi is more or less clinical. However, if facilities are available, the following investigations may be done:

1. Blood thiamine level: less than 4 µg/dl (normal is 10 ± 5 µg/dl) is suggestive;
2. Milk thiamine level: less than 7 µg/dl;
3. Red cell transketolase level: low. A dramatic response, within a few hours, to an intramuscular injection of 25 mg of thiamine is a good therapeutic test.

Treatment

As soon as the diagnosis is convincingly made, the child must receive 10 mg of thiamine intravenously. In the subsequent three days, he should be given 10 mg of the vitamin intramuscularly twice daily. Over the next six weeks, 10 mg daily should be administered orally.

The breastfeeding mother should receive thiamine therapy simultaneously.

Prognosis is excellent provided reasonable intake of thiamine is ensured.

Prevention

Ensuring that at least 0.4 mg of thiamine is provided in the daily diet (thrice the quantity in case of pregnant and lactating women) prevents beriberi.

RIBOFLAVIN DEFICIENCY

Riboflavin (vitamin B₂), another water-soluble vitamin, is a constituent of flavoprotein enzymes vitally concerned with the intermediary metabolism of carbohydrates. It is found in both animal and vegetable foods such as liver, fish, egg, kidney, meat, beans, yeast, green leafy vegetables, cereals, legumes, groundnut and milk (5 times more in cow milk than in human milk).

Often, deficiencies of thiamine and riboflavin may be coexisting. This relationship is now widely recognized.

Etiology

Since both breast milk and cow milk provide sufficient riboflavin for infant's needs, its deficiency usually occurs in children on restricted protein intakes or with dominant protein malabsorption state.

Its deficiency may also occur in infants under photo-therapy because of its being subject to photo-degradation.

Clinical Features

Manifestations include angular stomatitis, cheilosis (fissuring of lips), nasolabial seborrhea and, occasionally, magenta (purplish-red, smooth) tongue. There may occur corneal injection (vascularization) at the limbus, leading to excessive lacrimation, photophobia, eye pain and later interstitial keratitis.

1 Diagnosis

Diagnosis is essentially clinical. Laboratory investigations include:

1. Urinary excretion of riboflavin less than 30 µg/24 hours.
2. Excretion of less than 125 µg of riboflavin/g of creatinine in a random urine sample.
3. Increased erythrocyte glutathione reductase activity after the addition of flavin adenine dinucleotide (FAD).

Treatment

Therapy consists in administering riboflavin, 3 to 10 mg orally or 2 mg intramuscularly daily for a few days. This should be followed by 10 mg orally daily for about three weeks.

With this regimen, response is good. Complete recovery occurs provided that adequate intake of vitamin B₂ is ensured in the weeks and months ahead.

Prevention

In order to prevent riboflavin deficiency, it should be ensured that the daily diet provides at least 0.6 mg riboflavin per 1,000 kcal. It is advisable to administer supplements of riboflavin (the whole B-complex may be still better) to the infants and children belonging to vulnerable categories.

NICOTINIC ACID DEFICIENCY

Nicotinic acid (niacin) is also involved in the carbohydrate metabolism and plays vital role in the functioning of the skin, gastrointestinal tract, central nervous system and hemopoietic system.

This vitamin may be obtained either from the natural food sources or from the tryptophan endogenously. The natural food sources include milk, liver, pork, cheese, yeast, cereals, etc.

Etiology

Nicotinic acid deficiency is usually encountered in children receiving a maize diet as staple, in chronic diarrhea, in malabsorption states, and in anorexic states.

Clinical Features

The disease caused by nicotinic acid deficiency is called *pellagra*. It usually occurs in children of school-going age.

The characteristic lesions are seen over the exposed areas of the skin, such as limbs, neck, ("Casal necklace") and cheeks. It is worth noting that the lesions are symmetrical, of desquamating pigmentary dermatitis type and are aggravated by sunlight.

There is a widespread gastrointestinal inflammation, leading to red and sore tongue, dysphagia, nausea, vomiting and diarrhea.

Just like diarrhea, dementia is encountered much less in childhood than in adults. Most children with pellagra are, no doubt, quite apathetic.

Anemia as also other signs of malnutrition are usually present.

Diagnosis

It is purely clinical.

At times, severe protein-energy malnutrition in the form of kwashiorkor may warrant differentiation. Remember that in kwashiorkor the skin lesion tend to be around pressure sites and flexure surfaces in the trunk, groin and knee rather than over the exposed parts as is typical of pellagra.

Treatment

Nicotinamide, 50 to 300 mg daily in divided doses orally, given for two weeks followed by adequate supply of B-complex vitamins in diet brings about complete recovery.

Prevention

The disease may be prevented by providing a balanced diet containing 5 to 10 mg daily supply of nicotinamide.

PYRIDOXINE DEFICIENCY

Pyridoxine (vitamin B₆) plays a vital role in the metabolism of proteins and fatty acids. It is claimed to have a role in blood formation, in proper functioning of the nervous system and in conversion of tryptophan into nicotinic acid.

Its natural sources include liver, egg yolk, meat, wheat germ, soyabeans, yeast, peas, pulses and cereals. It is found in only small quantity in most vegetables and milk.

Etiology

Pyridoxine deficiency of nutritional origin is rare in childhood—in fact, in humans as such. Deficiency

may, however, complicate prolonged isoniazid or cycloserine therapy in tuberculosis or penicilamine therapy in Wilson disease. Pyridoxine-responsive convulsions and anemia have been described. Pyridoxine-dependency inborn errors of metabolism, e.g. homocystinuria, cystathioninuria, xanthurenic aciduria, kynureninase deficiency and hyperoxaluria, are also reported.

Clinical Features

The manifestations include convulsions and microcytic-hypochromic anemia refractory to iron therapy. Growth retardation and gastrointestinal symptoms like diarrhea may occur. Seborrheic dermatitis around nose and eyes, and sensory neuropathy occur only uncommonly in children. Cheilosis and glossitis are infrequent in childhood.

Diagnosis

High sense of suspicion of vitamin B₆ deficiency in infants with persistent convulsions, provided that hypoglycemia, hypocalcemia and birth injury have been excluded, would help to diagnose this condition. Such an infant should receive 50 to 100 mg of pyridoxine intravenously. If the response is gratifying, diagnosis is quite probable. The confirmation of diagnosis may be done by the tryptophan loading test.

The same applies to anemia refractory to iron deficiency.

Treatment

Administration of 5 mg of pyridoxine intramuscularly followed by 0.5 mg daily orally for two weeks causes complete recovery.

VITAMIN B₁₂ DEFICIENCY

See Chapter 27 (Pediatric Hematology).

FOLIC ACID DEFICIENCY

See Chapter 27 (Pediatric Hematology).

VITAMIN C DEFICIENCY

Ascorbic acid, which structurally resembles a monosaccharide sugar, is known to play important role in oxidation of tyrosine and phenylalanine, in formation

of hydroxyproline, in preventing depolymerization of collagen and maintaining integrity of ground substance, and in hemopoiesis.

Deficiency of vitamin C, though quite common in its subclinical form, has virtually disappeared in its overt form from the affluent countries. But, its frank cases still continue to be seen from time to time in some parts of the developing regions.

Etiopathogenesis

Scurvy may occur in the following situations:

- i. Primary protein-energy malnutrition, though during periods of gross retardation of growth, overt scurvy is usually not seen as is the case with rickets.
- ii. Secondary protein-energy malnutrition as in malabsorption.
- iii. Exclusively artificially-fed infants.
- iv. Even breastfed infants born to mothers deficient in vitamin C.
- v. Vitamin C dependency occurring in newborns accustomed to saturation levels of vitamin C since the mother had been taking very high doses of it during pregnancy to prevent colds, etc.
- vi. Infections which enhance the requirement of vitamin C.

The deficiency results in two major changes. First, there is impaired collagen synthesis, causing defective formation of osteoid and dentine. Secondly, there is a modification of the intercellular ground substance that binds the cells of the capillary walls. All this may lead to changes in the calcified tissues and capillary hemorrhages. In addition, there is an impaired wound healing and susceptibility to infections.

Clinical Features

Scurvy occurs usually in infants between the age of 6 months to 2 years. No age is a bar, however.

Infantile scurvy is characterized by gross irritability, excessive crying and tenderness to touch, more so in the lower limbs. The infant adopts the so-called "frog-position" in which he lies with the lower limbs that are partially flexed at the knees and hips and externally rotated. The posture of the lower limbs gives an impression as though these are paralysed (pseudoparalysis).

The palpable *subperiosteal hemorrhage* into the lower third of the femur may contribute to pain, thus

1 preventing movements of the leg further and strengthening the impression that the limb may be paralysed.

Hemorrhages may occur into the skin and mucous membranes. Hemorrhages into the gums may result in spongy, swollen, bluish purple gums, especially about the erupted teeth. Hemorrhages in the internal organs may cause hematuria, melena, proptosis and subdural swellings. Mild to moderate anemia is usual.

Scorbutic rosary may result from posterior displacement of the sternum. Unlike rachitic rosary, it is tender, sharp and angular and has a "step-shaped" configuration, the sternum, being depressed.

Childhood scurvy presents as follicular hyperkeratosis with development of minute hemorrhages at the root of the hair follicles. Bleeding into the skin, leading to petechiae or even large purpuric swellings, and gums may occur but subperiosteal hemorrhages are infrequent.

Differential Diagnosis

Pseudoparalysis of scurvy needs to be differentiated from the true paralysis of poliomyelitis. If the child is held at the shoulders and lifted, he will flex his legs and not allow these to touch the ground because of fear of pain in case of scurvy. In poliomyelitis, the paralysis is truly flaccid. In this situation, the infant's legs will just fall helpless on the ground rather than be lifted as in scurvy.

Pseudoparalysis may also occur in syphilis, suppurative arthritis and osteomyelitis. In the former, other signs of the disease are usually present, whereas the latter two conditions are usually unilateral.

Subperiosteal hemorrhage causing swelling over lower end of femur may have to be differentiated from hemarthrosis of hemophilia.

Bleeding into skin and mucous membranes needs to be differentiated from the bleeding diathesis of purpura and leukemia.

Diagnosis

Once clinical suspicion is aroused, the diagnosis may be confirmed by the following investigations:

- Ascorbic acid level in serum, white cells or buffy coat, i.e. platelet layer, is usually less than 0.1 mg%.
- Excretion of ascorbic acid in urine below 1.5 mg after a loading dose of 20 mg/kg by intravenous route 4 hours earlier.

- No or less than 20% excretion of ascorbic acid in urine after a loading dose of 10 mg/kg by oral route 24 hours earlier.
- X-ray changes: classical changes may be seen especially in the X-ray knee including lower part of femur and upper parts of tibia and fibula (Fig. 14.9).

A dense irregular white line, called *white line of Fraenkel*, appears at the epiphyseal ends of the long bones. Subsequently, adjacent to this line occurs an area of destruction (rarefaction). This area is called *fracture zone*. This is very susceptible to fractures and fissuring. The projection of the white line laterally, away from the limit of the shaft, may lead to formation of a spur or marginal cleft. This is what is known as *Corner sign*. It has great diagnostic value.

The rarefied epiphyseal centers may be sharply outlined. This is termed signet-ring or simply "ringing" of the epiphysis. There may be epiphyseal separation also.

The cortex is thinned because of generalized osteoporosis and the trabeculae have *ground glass appearance*.

Large subperiosteal hemorrhage may lead to lifting of the periosteum. This is seen as a regional increase in the soft tissue density. The affected bone looks like a dum-bell or a club. Later, when the hematoma is calcified during healing, it may become clearly visible in the X-ray.

In Menkes (kinky hair) disease, a sex-linked recessive neurodegenerative disorder due to copper deficiency, radiologic changes simulating scurvy may be observed.

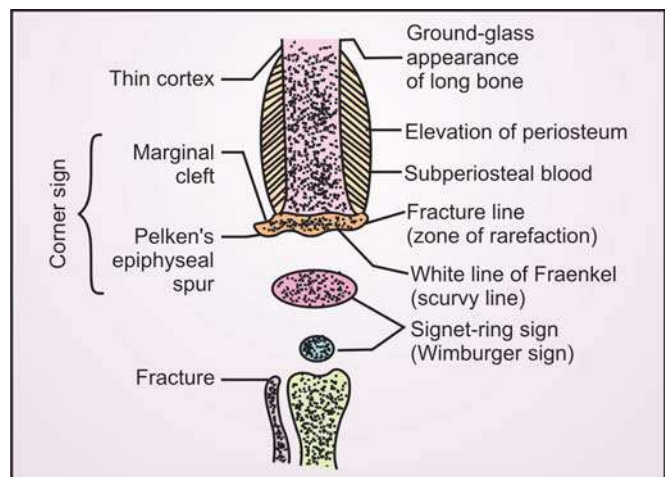

Fig. 14.9: Diagrammatic representation of radiological picture of scurvy

Treatment

It consists in giving a loading dose of 500 mg of vitamin C followed by a daily dose of 100 to 300 mg for several weeks. Oral administration is good enough.

Clinical response occurs rapidly—within 24 to 48 hours. Improvement in the radiological picture takes a week or two. Subperiosteal hemorrhages are likely to take months to disappear.

Prevention

Mothers should be encouraged to breastfeed the babies. Supplements of vitamin C, providing about 25 mg of it daily, should be introduced in the second or third month, especially in infants on artificial feeding. Mothers should be advised not to boil fruit juices. Boiling is known to destroy this vitamin. Also, lactating mothers should receive additional vitamin C, their daily need being 100 to 150 mg of it.

Amla (Indian goose berry), guava, tomato, orange, lemon, peas, beans, etc. constitute rich sources of vitamin C. Their intake should be encouraged in case of older children and pregnant and lactating mothers.

VITAMIN D DEFICIENCY

The ultraviolet rays of the sunlight are responsible for converting the 7-dehydrocholesterol, that is normally present under the skin, into vitamin D₃ or cholecalciferol. The latter is further converted to 25-hydroxycholecalciferol and 25-hydroxyergocalciferol in the liver. The last two forms are essential for maintenance of adequate calcium and phosphorus concentration in the extracellular fluid and for the formation of bone matrix. It is now established that 25-HCC is then converted to 1,25-dihydroxycholecalciferol. The latter is specifically helpful in promoting synthesis of “calcium transport protein” in the intestinal wall.

Etiology

Vitamin D deficiency produces rickets. Despite such a lot of sunshine, its incidence continues to be high in India and other countries of the Third World. This appears to be due to poor dietary intake of vitamin D and also due to poor exposure to sunlight. The latter seems to be related to the widely-prevalent practice of covering the infants with loads of clothes and from living in slums and crowded places. Poor exposure to

sunlight may also be related to the inactivity of the malnourished children.

Disturbed metabolism and poor synthesis of vitamin D from the skin, malabsorption state, diarrheal disease and excessive phylate with low calcium and low phosphate content of the diet may well be other causes of rickets in malnourished children. Our repeated observations of development of rickets in later age-group too, suboptimal intake of calcium and more gratifying response to a combination of vitamin D and calcium than to vitamin D alone in India strongly indicate both vitamin D and calcium (and perhaps phosphate too) deficiency contribute to the continuing high incidence of nutritional rickets in India and other developing countries. Obviously the problem of calcium deficiency (perhaps, in association with phosphate deficiency), in addition to vitamin D deficiency, in etiology of rickets in developing countries needs greater consideration. The preventive as well as therapeutic implications of this observation are vital.

Prevalence

Conservatively speaking, vitamin deficiency ricket should be the problem of temperate climate. Paradoxically, however, it has more or less disappeared from the temperate zones, except in migrant black population, in bed-ridden institutionalized children and in areas where milk supply is not fortified with vitamin D. This is ascribed to health education, enrichment of milk with vitamin D, wide use of vitamin D concentrates, and better standard of living and better health and medical care.

The problem of rickets in India is much greater than its extent suggested by the descriptions in various texts. In our experience, every other child in the age group 6 months to 5 years attending the Children Outpatient Department at the Jammu Medical College has evidence of active rickets which is often missed because of some other dominating presenting problem.

A high proportion of older children too have evidence of old rickets.

Congenital rickets is a rare entity occurring in neonates of mothers suffering from osteomalacia.

Clinical Features

Rickets is a disease of rapid growing period. The peak incidence is encountered in the age group 6 months to

1 2 years. It is uncommon in infants under 3 months of age.

The earliest manifestations are quite vague and nonspecific. These include irritability, restlessness and profuse sweating over the head (more so during sleep).

Major signs encountered in overt rickets are summarized below:

Head: Bossing (frontal and parietal) macrocephaly with flattening of vertex (box head, caput quadratum or hot cross bun), increased size and delayed closure of fontanels, craniotabes (a peculiar softening of occipital and posterior parietal bones which give in like a ping-pong ball under pressure from thumb). At times, craniotabes may be encountered in normal preterm babies. Remember, preterm infants have higher incidence of rickets compared to full-term infants.

Teeth: Delayed dentition.

Thorax: Rachitic rosary (smooth rounded, nontender costochondral beading as in Figures 14.10 and 14.11), pigeon-chest deformity (pectus carinatum), Harrison sulcus or groove (a depression along the insertion of diaphragm into the ribs), flaring of lower ribs. "Violin-shaped" deformed chest is characteristic. Infrequently, sternum is unusually depressed, the so-called *pectus excavatum* (Fig. 14.12). A concavity at inferior angle of scapula may be detected.

Spine: Scoliosis, kyphosis.

Limbs: Widening of wrists, ankles (with double malleoli) and other epiphyses due to expansion and cupping of growing ends of bones. Genu valgum (knock knees as in Figure 14.13) or genu varum (bowlegs as in Figure 14.14) may result.

Miscellaneous: As a result of poor muscle tone and relaxation of ligaments, the child may have delayed milestones, flat feet, pot-belly and some degree of visceroptosis so that liver may become palpable without its having been enlarged.

At times, laxity of ligaments may be of such a magnitude that the limbs can be bent in to any position. *Acrobatic rickets* is the name given to this condition. Constipation is often present. Rarely, tetany may accompany rickets due to reduced level of ionized calcium in plasma.

If rickets is not adequately treated in time, bone deformities may be left as scar the so-called "old rickets". Short stature may also follow.

Differential Diagnosis

Physiologic bowing of the legs seen in some healthy toddlers due to normal deposition of adipose tissue over the lateral aspects is not accompanied by other signs of rickets and disappears in due course of time without any treatment. Similarly, slight valgus position of the feet may cause some degree of *physiologic genu valgum* without any other rickety deformity.

Renal rickets may result from deficiency in the tubular reabsorption of phosphate or cystinosis. In the former condition, called phosphaturic rickets or late rickets, manifestations develop at a later age than is usual in the infantile rickets and it is resistant to usual doses of vitamin D. It is encountered more often in girls but is more advanced when boys are affected. In cystinosis (*Fanconi syndrome*), cystine crystals are found throughout the reticuloendothelial system and there are multiple renal tubular defects (glycosuria, aminoaciduria, tubular acidosis, phosphaturia, potassium loss, and, at times, uricosuria and sodium loss). The rickets associated with this condition needs heavy doses of vitamin D (50 thousands to 3 lakhs units/day) for healing.

Pseudodeficiency rickets (hereditary vitamin D-dependent rickets), an autosomal recessive disorder involving deficiency of α -25 (OH)₂ D₃, is characterized by severe rickets which develop in early infancy but which fail to respond to vitamin D therapy up to 4,000 units/day. It responds to long-term massive doses of it or still better to oral therapy with α -hydroxyvitamin D₃.



Fig. 14.10: *Vitamin D-deficiency rickets.* Note the prominent costochondral beading which is described as rounded, smooth but nontender (rachitic rosary). In contrast, the beading in scurvy (scurvitic rosary) is angular, sharp and tender

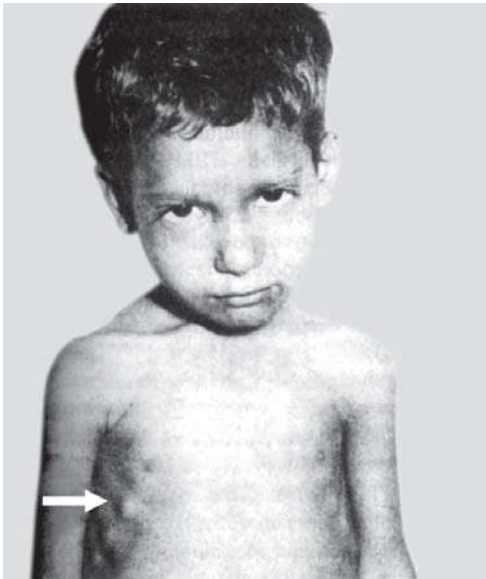

Fig. 14.11: Rachitic rosary. Unlike scorbutic rosary, it is smooth, rounded and nontender

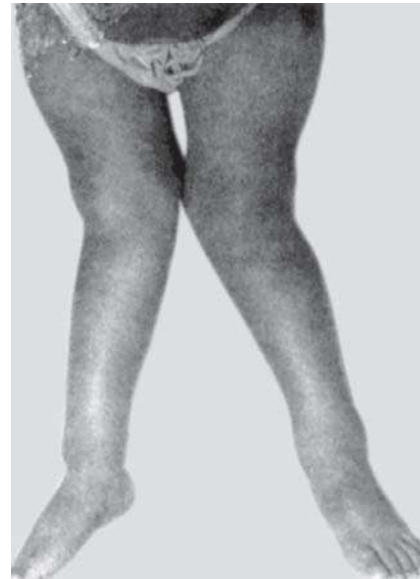

Fig. 14.13: Gross knock-knee deformity of rickets



Fig. 14.12: Funnel-chest deformity (pectus excavatum) in a child with advanced rickets

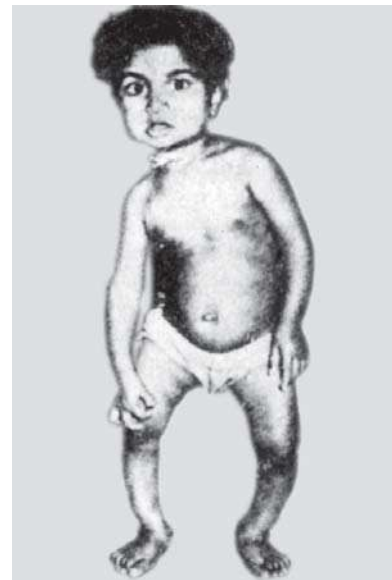

Fig. 14.14: Gross bowleg deformity of rickets. Note widening of ankles and “double malleoli”

Hypocalcemia is characteristic of this variety of rickets.

Celiac rickets, in fact rickets associated with any major malabsorption state, is most readily excluded by tests of intestinal absorption and histology.

Diagnosis

Biochemical findings include raised alkaline phosphatase (except in malnourished children), usually a

normal serum calcium and a reduced phosphorus. Today, reduction in the serum 25-hydroxyvitamin D level is considered a sensitive and reliable index of rickets even in malnourished children.

X-ray findings are best seen at the wrist (Fig. 14.15). These include cupping (saucer-like depression), flaring (widening) and fraying (rarefaction) of the lower ends of radius and ulna. Long bones, therefore, give the “champagne glass” appearance. There is an increase

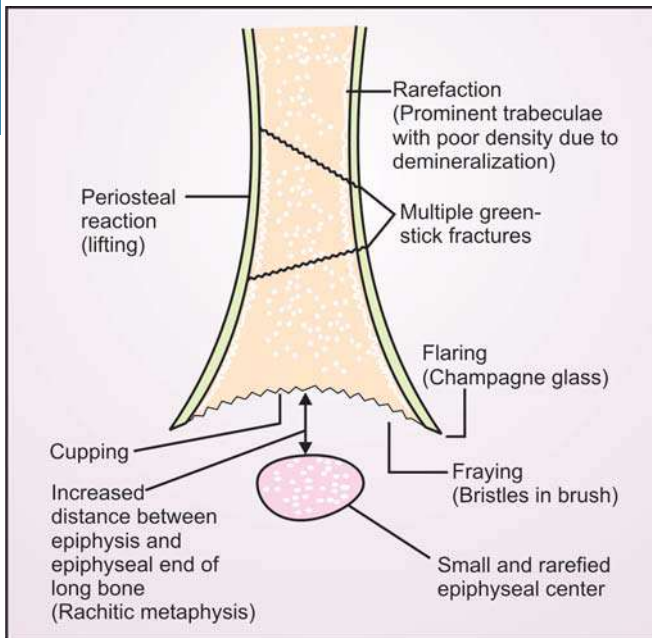

Fig. 14.15: Rickets: Diagrammatic representation of radiologic appearance of radius

in the distance between the epiphyseal center and shaft of long bones due to radio-translucency of the osteoid. Periosteal reaction is present, so is the prominence of trabeculae.

Treatment

Specific treatment (Stoss therapy) consists in administering a single massive dose of vitamin D₃ (3,00,000 units up to 1 year of age; 6,00,000 units for later ages) orally or intramuscularly together with supplementary calcium and phosphorus. Though serum alkaline phosphatase and phosphorus tend to return to normal within just 5 days, apparent healing (radiologically) can be seen in 10 to 14 days. Radiologic evidence of healing (say at wrist) is in the form of:

- appearance of provisional zone of calcification
- mineralization of “fraying” at the epiphyseal end
- recalcification of osteoid.

In order to achieve real consolidation of cure, it may be desirable to give additional one or two periodic massive doses of vitamin D as also supplementary calcium and phosphorus in the subsequent months.

Alternatively,

1. 60,000 units of vitamin D₃ daily orally for 10 days.
2. 20,000 units of vitamin D₃ daily orally for 30 days

Gross orthopedic deformities, especially in adolescents, may occasionally need surgical correction (say, osteotomy).

A poor response to adequate doses of vitamin D indicates refractory or resistant rickets due to malabsorption state, chronic renal disease (renal rickets), hypophosphatemia, hypocalcemia, Fanconi syndrome or Lowe syndrome. Prolonged anticonvulsant therapy, magnesium deficiency, chronic liver disease, etc. may also lead to unsatisfactory response.

Overdosage (at least 50,000 IU daily for a minimum of 3 weeks) may cause *hypervitaminosis D*. The manifestations resembling the so-called “*infantile cortical hyperostosis*” (Caffey disease) include irritability, anorexia, hypotonia, constipation, polydipsia, polyuria, dehydration, anemia, calciuria, metastatic calcification, aortic valvular stenosis, hypertension, retinopathy, cornea cloudiness and growth failure. ESR is usually high. There may be fever. Certain bones (usually mandible, clavicle and scapula) develop soft tissue swellings over them. A characteristic radiologic finding is hyperplasia of subperiosteal bone. Response to withdrawal of vitamin D and calcium and therapy with aluminium hydroxide, cortisone or chelating agent, sodium versenate, is good.

Prevention

Availability of at least 400 IU of vitamin D through sun-shine, diet or supplements must be ensured. Health education to parents against overclothing the infants and young children and proper housing should be given.

REFRACTORY RICKETS

The term, refractory rickets, refers to rickets that is resistant to the usually recommended doses of vitamin D.

Table 14.3 gives its etiologic classification.

Table 14.4 gives clues to etiologic diagnosis. Treatment varies with the etiologic diagnosis. In general, *vitamin D-resistant rickets* needs high doses of vitamin D, 2,000 units/day till bony maturation is complete. It must be supplemented with phosphates in the form of disodium hydrogen phosphate 13.6 g and phosphoric acid 5.9 g/day. In place of vitamin D, 1,25(OH)₂ vitamin D in a dose of 1 µg/day may be employed for better outcome.

Table 14.3: Etiology of rickets with special reference to refractory rickets in relation to type I and type II rickets

Type I rickets

Vitamin D deficiency: Poor consumption, malabsorption state, poor exposure to sunlight.

Disturbed vitamin D metabolism from liver disease: Poor formation of 25 OH vitamin D₃ degradation of vitamin D₃ to 25(OH)D-26, 23-lactone (chronic anticonvulsant therapy causing stimulation of microsomal enzyme in liver).

Disturbed vitamin D metabolism from renal disease: Enzyme, 1-hydroxylase, deficiency in tubules interferes with conversion of 25-OH vitamin D to 1,25-(OH)₂ vitamin D₃. This is termed *vitamin D-dependent rickets (type I)*.

Failure of target cells to 1,25-diOH vitamin D. This is termed vitamin D-dependent rickets (type II).

Failure of kidney to form 1,25(OH)₃ vitamin D₃. This is termed *renal dystrophy*.

Type II rickets

Poor intake or absorption of phosphates

Defective reabsorption of phosphates by the renal tubules:

Fanconi syndrome, familial hypophosphatemic vitamin D refractory rickets, isolated phosphaturia, renal tubular acidosis, oncogenous tumors (oncogenous rickets) as in von Recklinghausen disease, epidermal nevus syndrome or linear nevus syndrome.

In case of vitamin D-dependent rickets, the recommended dose of vitamin D is 10,000 to 50,000 units/day. Alternatively, 1,25 dihydrovitamin D₃ 0.5 to 2.0 µg/day may be employed for vitamin D-dependent rickets (type 1).

Rickets accompanying chronic anticonvulsant therapy may be prevented by ensuring adequate dietary intake of calcium and an extra 500 to 1,000 IU of vitamin D₃ each day.

VITAMIN E DEFICIENCY

Alpha-tocopherol is the most biologically active among the eight related fat-soluble compounds formed by the tocopherols and their unsaturated derivatives, the tocotrienols.

The compound, i.e. vitamin E, occurs naturally in foods eaten by humans, such as vegetable oils including *soyabean*, wheat, germ, safflower oil, egg yolk and leafy vegetables.

This vitamin is believed to be important in maintaining the stability of biological membranes. Many of its properties are yet in shade, earning it the designation “shady lady of nutrition”.

Table 14.4: Clues to diagnosis of refractory rickets

Clue	Diagnosis
Clinical	
Familial	Familial hypophosphatemic vitamin D refracting rickets, 1-OH deficiency vitamin D-dependent rickets, renal tubular acidosis (distal)
Manifesting before 6 months of age	Familial conditions like Fanconi syndrome, cystinosis, 1-hydroxylase deficiency
Manifesting after 6 months of age but before 12 months	X-linked dominant vitamin D refractory rickets
Manifesting in early childhood	Renal tubular acidosis
Manifesting in late childhood	Renal osteodystrophy, glycine phosphaturia
Gross muscle weakness	Renal tubular acidosis, glycine phosphaturia
Renal/ureteric colic	Renal stone, renal tubular acidosis
Nausea, vomiting, lethargy	Renal osteodystrophy, renal tubular acidosis, hypophosphatasia
Mental deficiency, buphthalmos	Lowe syndrome
Highly pigmented skin, cystine crystals in cornea on slit lamp exam	Cystinosis
Sutural diastasis, short ribs, cutaneous dimples, hypotonia, failure to thrive	Hypophosphatasia
Lab investigations	
Low phosphate with amino aciduria	Vitamin D deficiency secondary to malabsorption, liver disease, chronic anticonvulsant therapy
Low phosphate without amino aciduria, isolated phosphaturia, normal pH	Familial hypophosphatemic vitamin D refractory rickets, oncogenic tumors
Low pH	Renal tubular acidosis
High phosphate	Renal osteodystrophy.

Its requirement should, therefore, be according to the intake of polyunsaturated fats. It is claimed to be 0.5 mg for every gram of linoleic acid.

In man, vitamin E deficiency is fortunately uncommon. When it occurs, the causes include prematurity and malabsorption states.

In the premature infant, vitamin E deficiency produces hemolytic anemia 4 to 6 weeks after birth. Additional problems include edema, skin changes, retinopathy of prematurity (ROP), bronchopulmonary dysplasia and intraventricular hemorrhage. It is worth noting that the deficiency occurs most often in babies who are being fed the milk that is quite rich in linoleic acid. Another factor that may precipitate vitamin E deficiency and hemolytic anemia in the premature infant is the administration of supplementary iron without added vitamin E.

Impaired reproductive ability, muscular dystrophy (fatty type), growth retardation, etc. are some of the other disorders in which the contribution of vitamin E deficiency, though proved in experimental animals, remains to be convincingly demonstrated in humans.

The most accepted practical implication of the comments on vitamin E boil down to this: premature infants fed on formulas rich in linoleic acid and fortified with iron must receive 0.7 IU of vitamin E/100 kcal or 1 IU/g of linoleic acid to avoid occurrence of hemolytic anemia.

Some authorities recommended administration of vitamin E (IM) once daily for several days after birth in infants who receive excessive concentration of oxygen.

VITAMIN K DEFICIENCY

Vitamin K is concerned with synthesis of coagulation factors II, VII, IX and X in the liver. Green leafy vegetables, soyabeans and fish are its natural sources. Enough of this vitamin is produced by the intestinal flora.

Therapeutically, water-soluble analogues of vitamin K have been synthesized.

Deficiency of vitamin K may occur in the following situations:

1. Newborns before adequate colonization of the intestines by bacterial flora has indeed occurred.
2. Newborns fed on unsupplemented breast milk. Though both cow and human milk have low content of vitamin K, the former supplies four times more vitamin K than the latter.

Daily requirement of vitamin K is 12 µg but human milk provides only 1.5 µg/100 ml of it.

3. Infants fed unsupplemented milk formulas based on soyabean isolates
4. Chronic intestinal parasitosis
5. Malabsorption states
6. Biliary obstruction
7. Oral antibiotics.

The commonest manifestation of vitamin K deficiency is what is known as the *hemorrhagic disease of the newborn*. Its causes include a low level of vitamin K in breast milk, hepatic immaturity and inadequate synthesis of vitamin K in the GIT by the bacterial flora. It usually occurs in breastfed infants. Generally, bleeding from the GIT, intracerebral hemorrhage or bleeding from the umbilical stump occurs in the first week, usually round about the third day after birth. Therapy consists of blood transfusion and parenteral administration of vitamin K, 2 to 5 mg.

Recently, occurrence of vitamin K deficiency-related hemorrhagic disease in older neonates and infants is being increasingly reported. Whereas such factors as chronic diarrhea, malabsorption, ascariasis, biliary tract obstruction, poor vitamin K intake and broadspectrum antibiotics could well be the cause in many cases, there remain some cases without any well-defined etiologic factor.

Whether, as a prophylaxis against this complication, vitamin K should be given to every infant immediately after birth remains controversial. According to the American School of Thought, 1 mg of vitamin K should be given to all newborns intramuscularly to lessen the incidence of neonatal hemorrhage from 2 to 5% to as low as 0.3%. The British School of Thought would restrict such prophylaxis to infants born after a traumatic or instrumental delivery. Remember, excessive administration of vitamin K may cause hemolytic anemia, hyperbilirubinemia and kernicterus, especially in preterm and G-6-PD deficient infants.

FURTHER READING

Articles/Chapters

1. Akikusa JD, Garrick, Nash MC. Scurvy: forgotten but not gone. *J Pediatr Child Health* 2003;39:75-77.
2. Shah P. Kapil U. Vitamin A deficiency (VAD) disorders. In Gupte S (Ed): *Textbook of Pediatric Nutrition*. New Delhi: Peepee 2006:193-200.

3. Singh H, Gupta S, Kansal S. Rickets. In Gupte S (Ed): *Textbook of Pediatric Nutrition*. New Delhi: Peepee 2006: 213-217.
4. Sommer A. Vitamin A prophylaxis. *Arch Dis Child* 1997;77:191.
2. Browman BA, Russel RM. *Present Knowledge in Nutrition*, 8th edn. Washington DC: ILSI 2001.
3. Lerch C, Meissner T. Interventions for the prevention of nutritional rickets in term-born children. *Cochrane Database Syst Rev* 2007;4: CD006164.

Books/Monographs

1. Berger H, Gracey M. *Clinical Nutrition of the Young Child (Vol 2: Water-soluble vitamins)*. New York: Nestec Vevey/Raven 1994.
4. Thacher TD, Fisher PR, Strand MA, Pettifor JM. Nutritional rickets around the world. *Ann Trop Pediatr* 2006;26:1-16.



CLASSIFICATION

The human body minerals may be categorized as under:

- I. Those known to be essential.
 - A. Electrolytes, e.g. sodium and potassium
 - B. With structural role, e.g. calcium and phosphorus
 - C. As component of hemoglobin, e.g. iron
 - D. Minor minerals, e.g. copper, zinc, cobalt, iodine
- II. Those whose precise functions are not yet known, e.g. nickel, tin, silicon, and vanadium.

The term, *micronutrients*, denotes substances which are needed by the body in minute quantities, i.e. mg/day rather than g/day in case of macronutrients. Less than 0.01% of human body is formed by them.

The best known micronutrients are vitamin A, iron and iodine which already have prophylaxis programs at national and international levels.

IRON DEFICIENCY DISORDERS

Iron deficiency exists in two forms:

1. Iron deficiency anemia (IDA) with overt manifestations such as anemia, poor growth and development, reduced learning capacity, cognitive function and work capacity.
2. Iron-deficient stores which sooner or later end up as IDA.

For details about IDA, see Chapter 27 (Pediatric Hematology).

ZINC DEFICIENCY

Next to iron, it is the most abundant trace element in the human body. It is an essential component of at

least 20 enzymes, including alkaline phosphatase, carbonic anhydrase and pancreatic carboxypeptidase. It plays a vital role in protein synthesis and RNA. Its concentration in hair is deemed to reflect the zinc status of a subject. It is also present in erythrocytes, prostate, eye, bone and endocrine glands. Total body zinc content of a newborn is about 60 mg and that of an adult about 1,600 mg.

The dietary sources of zinc include meat, liver, fish nuts, grains, dry beans and legumes. Daily requirement is some 200 mcg.

Etiology

Zinc deficiency may occur in protein-energy malnutrition, malabsorption states, regional ileitis, rheumatoid arthritis, sickle-cell anemia, achondroplasia, chronic blood loss, excessive sweating and hyperzincuria in catabolic states or viral hepatitis. Prolonged parenteral nutrition, if not supplemented with zinc, may also cause zinc deficiency state. Consumption of fibres and phytates in excess hampers zinc absorption.

Clinical Features

Clinical manifestation of zinc deficiency include growth retardation, hypogonadism, anemia and hepatosplenomegaly. This peculiar syndrome called, "adolescent nutritional dwarfing", has been described particularly from Iran and Egypt, though cases have been seen in India and other developing countries. However, a convincing cause and effect relationship between this syndrome and zinc deficiency remains to be established. Also, it has been said that zinc deficiency in such cases may well be due to poor

absorption because of phytates, calcium and other dietary components rather than low dietary intake.

Additional features of zinc deficiency include protracted diarrhea, delayed wound healing, anorexia, failure to thrive, pica, impaired taste perception (hypogeusia), hyperkeratotic skin and, perhaps, infantile tremor syndrome.

Acrodermatitis enteropathica is an inborn error of zinc metabolism in which there are skin changes at the extremities and around the orifices, diarrhea, alopecia, atrophy of nails and failure to thrive. This autosomal recessive condition usually manifests shortly after weaning and shows dramatic and sustained response to therapy with zinc.

Diagnosis

The laboratory confirmation for zinc deficiency may be obtained from a plasma zinc level of below 70 µg/dL or a hair zinc level of below 70 µg/g dry weight.

Treatment

Treatment of zinc deficiency consist in giving zinc sulfate, 0.2 to 1 mg of elemental or 1 to 5 mg of the salt as such/kg body weight/day. In very severe deficiency states, as high a dose as 20 to 40 mg/day of elemental zinc may be administered.

COPPER DEFICIENCY

Copper, rightly called the “iron twin”, plays a vital role in the utilization of iron stores and in the activity of many important enzymes, including cytochrome oxidase, monoamine oxidase, dopamine beta-hydroxylase, delta-aminolevulinic acid dehydrogenase, ascorbic acid dehydrase, uricase and tyrosinase. Total body copper content of a newborn is about 14 mg and that of a young adult about 100 mg. Thus, there is an average growth requirement of 10 µcg/day. It is distributed in all tissues of body, including kidney, liver, brain, heart, bone marrow and bones.

Whereas in a newborn as much as 50% of body copper is found in the liver, the corresponding figure in a young adult is only 5%. Thus, just, as is the case with iron, copper stores of an infant are sufficient for the first six months of life. In the liver, copper is incorporated into a protein complex, “ceruloplasmin”.

Copper is widely distributed in foodstuffs with the exception of milk; breast milk contains 40 µg/dl and cow milk 20 µg/dl of it.

Deficiency may be encountered in the following situations:

- Protein-energy malnutrition, including nutritional rehabilitation employing predominantly soy milk and zinc supplementation in excess
- Malabsorption states
- Chronic diarrheal disease
- Prolonged parenteral feeding without copper supplements
- Premature infants being fed low-copper milk preparations.
- *Deficiency of copper* manifests as
 - Anemia, neutropenia, vasculer abnormalities.
 - Hypopigmental hair and skin
 - Osteoporosis, metaphyseal fraying and fractures
 - Deficient immune function.
- *Excess of copper*, usually genetic in origin, is associated with:
 - Wilson disease
 - Menke’s kinky hair disease
 - Indian childhood cirrhosis.

COBALT

It is apart of vitamin B₁₂ and is required for iodine utilization. It increases iron absorption. Its deficiency causes anemia and goiter. Its excess can cause dilated cardiomyopathy which is indistinguishable from primary dilated cardiomyopathy. Its excess may also cause goitre.

SELENIUM

Selenium is an integral part of glutathione peroxidase and is linked to vitamin E and is an important antioxidant cofactor.

Its deficiency leads to dilated cardiomyopathy which used to be common in certain geographical parts of China (“Endemic DCM/ Keshan disease”). It was first described in 1979 and may occur in young children and women. It is a preventable cardiomyopathy, but once DCM sets in, total reversal to normality is not possible even with selenium supplementation. Four forms of Keshan’s disease are recognized: an acute variety with shock, a subacute variety with both hypotension and CHF, a chronic variety with CHF and the fourth one, which presents as asymptomatic cardiomegaly. It is virtually indistinguishable from various presentations of primary DCM.

Deficiency may also cause liver necrosis, arthritis and myopathy.

Its excess may cause dental caries, alopecia and garlic odor in breath.

CHROMIUM

Chromium deficiency is associated with poor glucose tolerance and neuropathy. It facilitates insulin action. Its excess can lead to dermatitis and renal failure.

MANGANESE

Manganese is an enzyme cofactor in superoxide dismutase, oxidative phosphorylation and bone mineralization.

Deficiency may produce growth retardation, weight loss, red hair and hypcholesterolemia.

Excess may cause cholestasis, encephalopathy, basal ganglia disorder, goiter and cardiomyopathy.

FLUORINE

Fluorine is a component of bone and teeth. Up to 1 ppm in drinking water is desirable. Deficiency leads to dental caries and excess to fluorosis.

MOLYBDENUM

Molybdenum is important in uric acid metabolism. Deficiency may lead to tachycardia, irritability, central scotoma and upper GIT cancers. Excess may unmask gout and cause bony defects like genu valgum.

NICKEL

Nickel is a component of urease and nickel plasmin. Excess may produce dermatitis, liver necrosis and lung cancer.

VANADIUM

Vanadium deficiency is associated with nutritional edema.

SILICON

Silicon is important in cross linkage of collagen and deficiency may produce defective bone growth. Excess may cause fibrosis lung.

ARSENIC

Arsenic is important in skin and nail formation.

IODINE DEFICIENCY (ENDEMIC GOITER)

Enlargement, of the thyroid gland as a result of iodine deficiency is endemic in sub-Himalayan belt extending from Ladakh through Himachal Pradesh, Uttar Pradesh, Bihar, Bengal, Sikkim, Bhutan, Assam, Arunachal Pradesh, Meghalaya and Nagaland to Burma. Isolated pockets are being increasingly identified, e.g. Rajasthan, Gujarat, Maharashtra, Madhya Pradesh, Andhra and Kerala (Table 15.1).

Since sea-water is a rich source of iodine, goiter is rare in population living along the sea coast.

Subclinical deficiency of iodine may manifest in the form of goiter only at puberty or confining to the periods of stress.

The public health importance of goiter lies in the high incidence of deafmutism, mental retardation (often accompanying frank cretinism), ataxia and spasticity in the endemic areas.

Availability of iodized salt (common salt fortified with sodium or potassium iodate in a ratio of 1 in 40,000) is the most economic, convenient and effective means of mass prophylaxis in endemic areas. An alternative to iodized salt is iodized oil given as an intramuscular injection once in 3 years as a cheap, safe and long-acting prophylactic measure.

CALCIUM DEFICIENCY

By and large 99% of body calcium is found in bones and teeth. The remaining 1% is involved in clotting cascade, nerve conduction, muscle stimulation, vitamin D metabolism and parathyroid function.

Its metabolism is regulated by vitamin D, calcitonin and parathyroid hormone.

Table 15.1: Clinical grading of thyroid (revised)

Grade 0a:	Thyroid not palpable or, if palpable, not larger than normal.
Grade 0b:	Thyroid distinctly palpable but usually not visible with the head in a normal or raised position and considered to be definitely larger than normal, i.e. at least as large as the distal phalanx of the subject's thumb
Grade I:	Thyroid easily palpable with the head in either a normal or raised position. The presence of a discrete node qualifies a patient for inclusion in this grade
Grade II:	Thyroid easily visible at a distance
Grade III:	Goiter visible at a distance
Grade IV:	Monstrous goiter

In order that calcium performs its function well, adequate magnesium, phosphorus and vitamin A, C, D and E should be available in the body.

Whereas availability of fat facilitates its absorption from the gut, phytates (cereals) reduces its absorption. Sources of calcium include milk and its products and millets (say, ragi).

Clinical Features

1. Tetany: Muscle cramps, numbness, tingling
2. Impaired growth
3. Calcium-deficiency rickets
4. Osteoporosis
5. Nonspecific: Arthralgia, palpitations

MAGNESIUM DEFICIENCY

Next to potassium, it is the most abundant mineral cation in cells. It is involved in

- Synthesis of fatty acids, proteins cyclic AMP.
- Oxidative phosphorylation
- Autonomic control of heart.

Sources include plant foods and meat.

Requirements are:

- First 6 months 40 mg/day
- Second 6 months 60 mg/day
- Later 200-300 mg/day

Causes

These include PEM, diarrheal disease, malabsorption syndrome (MAS), and chronic renal failure.

Clinical Features

1. Irritability
2. Tetany
3. Increased or decreased reflexes

SODIUM DEFICIENCY

See Chapter 16 (Fluids, Electrolytes and Acid-base Balance...).

POTASSIUM DEFICIENCY

See Chapter 16 (Fluids Electrolytes and Acid-base Balance...).

INFANTILE TREMOR SYNDROME (ITS)

ITS is characterized by tremors, anemia, kwashiorkor-like hair changes and regression of milestones in a plump-looking infant despite fair evidence of

malnutrition. The entity appears to be nutritional in origin with zinc deficiency as the major contributor to the development of the clinical spectrum. For details, see Chapter 36.

LOW BIRTHWEIGHT (LBW) INFANTS

LBW infants (weight <2500 g), usually outcome of intrauterine growth retardation (IUGR) form 25-30% of all births in India compared to 17% globally. Improvement in survival of LBW babies has short-term implications in the form of poor growth and development in infancy long-term risk of developing degenerative disease (diabetes, coronary heart disease, hypertension, stroke) in adulthood.

IMMUNONUTRITION

Over the years, the concept of employing nutrients for improving the immune function of the body has come of age.

The so-called "immunonutrients", having favorable effect on the immune system, are added to standard nutritional support solutions for deriving immunological benefits. They may be administered in supranormal doses enterally or, at times, parenterally for modulating response to surgery, trauma or sepsis. The most commonly employed and researched immunonutrients are arginine (a nonessential amino acid), glutamine (precursor for nucleotide), omega-3 polyunsaturated fatty acids, nucleotides, vitamins A and E, iron, zinc, selenium, prebiotics and probiotics.

Undoubtedly, immunonutrition has the potential to cut down morbidity and mortality in critically ill children with gastrointestinal disease, immune deficiency disorders, polytrauma and sepsis. The preliminary reports strongly point to its promising role in cancer prevention.

FURTHER READING

Articles/Chapters

1. Bhaskaran P. Micronutrient malnutrition, infection and immunity: An overview. *Nutr Rev* 2002;60:S40-S45.
2. Diaz JR, de las Cagigas A, Rodriguez R. Micronutrient deficiencies in developing and affluent countries. *Eur J Clin Nutr* 2003;57:S70-S72.
3. Oken E, Duggan C. Update on micronutrients: iron and zinc. *Curr Opin Pediatr* 2002;14:350-353.

Book/Monograph

1. Elizabeth KE. *Nutrition and child Development*, 3rd edn. Hyderabad: Paras 2004.



Fluids, Electrolytes and Acid-base Balance and its Disturbances

Lalita Bahl, Suraj Gupte

PHYSIOLOGIC CONSIDERATIONS

Total Body Water

Water accounts for 70 to 80% of a neonate's body weight and 55 to 60% body weight by the age of 1 to 2 years. Total body water (TBW) is equal to $0.61 \times \text{weight (kg)} + 0.251$. However, TBW is relatively less in obesity since fat is known to have low water content.

TBW consists of two major compartments, *intracellular* (ICF) and *extracellular* (ECF), and the two minor compartments, *transcellular* (TCF) and *slowly exchangeable compartments* (SEF) (Fig. 16.1).

ICF volume represents 30 to 40% of body weight and is the sum-total of fluids from the cells in different locations.

ECF volume represents 20 to 25% of body weight and consists of plasma water and interstitial water. In normal children, ECF constitutes 20-25% of TBW total body weight. Out of this, 5% is plasma and 15% interstitial water. It is at peak at birth (more than ICF) but drops down postnatally secondary to diuresis. The adult ECF:ICF ratio is reached by one year of age.

$$\text{ECT} = \text{Weight (kg)} \times 0.239 + 0.325$$

TCF volume represents around 2% of body weight, its most important components being gastrointestinal secretions, urine in kidneys and lower urinary tract, CSF aqueous humor, and synovial, pleural and peritoneal fluids. TCF is affected by transepithelial transport and is accurately described as extracorporeal.

SEF volume, representing 8 to 10% of body weight, is contained in bones, dense connective tissues and cartilages. This fluid is not accessible to the TBW on account of slow exchange rate. However, the fluid infused into the bone can enter the plasma volume

due to the presence of haversian system, thereby acting as an important factor in situations where intraosseous fluid resuscitation is warranted.

Regulation of body water is controlled by its intake and excretion, the latter being the more vital regulating mechanism. Water intake is normally stimulated by the conscious desire to drink water, i.e. thirst. Thirst, regulated by a centre in the mid-hypothalamus as also by the volume of body water, is interrelated with the antidiuretic hormone (ADH), i.e. arginine vasopressin plus some ADH-independent thirst centers. Increased thirst (polydipsia) or decreased thirst (adipsia) may result from disorders of thirst mechanism as in psychologic/neurologic disorders, malnutrition, potassium deficiency, and defect in renin-angiotensin system.

Excretion refers to obligatory water losses which include insensible losses from lungs and skin, urinary losses, and stool losses. For every 100 kilocalories, fluid losses are 65 ml in urine, 40 ml in sweat, 15 ml in breath, and 5 ml in stools. Urinary water excretion is controlled by two complementary mechanisms:

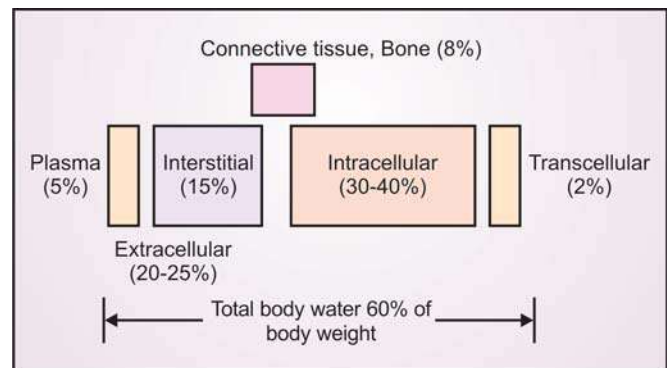

Fig. 16.1: Total body water and its breakup in different compartments as percentage of body weight in a child

1. ADH production, storage and release, and
2. Renal epithelial tubular cell response to ADH. ADH is synthesized in the supraoptic nuclei and is stored in the posterior pituitary. Its release into the blood stream occurs in response to stimuli from the hypothalamus. Effective osmotic pressure of ECF regulates secretion of ADH. The threshold for release of ADH is 280 mOsm/kg of H₂O. As small an alteration in plasma osmolality as 1 to 2% is capable of initiating or inhibiting its release.

Situations in which ADH secretion is high include administration of IV hypertonic saline solution leading to hypertonicity of ECF, fall in plasma or ECF volume, drugs like morphia, phenobarbital, epinephrine, acetylcholine, analgesics, histamine, etc. and emotional stress.

Situations in which ADH secretion is inappropriately high in relation to osmolality of blood include CNS disorders [meningitis, encephalitis, Guillain-Barré syndrome (GBS), tumors, subarachnoid hemorrhage, head injury], perinatal asphyxia, tuberculosis, pneumonias, and certain malignancies.

Conversely, ADH secretion is inhibited when excessive water is administered leading to hypotonicity (dilution) of the body fluids.

ADH acts primarily by increasing the permeability of the renal collecting ducts to water.

Aldosterone, a secretion of the adrenal cortex, enhances tubular reabsorption of sodium, thereby regulating the ECF volume.

Electrolytes

Body water is not just pure H₂O. It contains agents that have the distinction of conducting an electric current in solution. These substances, termed *electrolytes*, may be with positive charge (*cations*) or negative charge (*anions*). Important cations are sodium, potassium, calcium and magnesium. Important anions are chloride, bicarbonate, sulfate, organic acids and protein acids. Sodium exists predominantly in ECF whereas potassium and phosphates are primarily in ICF. Tonicity of body fluids is termed *osmolality* which means number of osmotically active particles per 1,000 g of water in a solution (mOsm/kg). From clinical point of view, osmolality and osmolarity carry similar meaning. Since sodium and the accompanying anions, chloride and bicarbonate are responsible for 90% of the plasma

osmolality, a rough estimate of ECF osmolality can be obtained by doubling the concentration of plasma sodium, except when there is an accompanying hyperglycemia or hyperlipidemia. A more accurate method of obtaining plasma osmolality is by employing the following formula:

$$\begin{aligned} \text{Osmolality (plasma)} &= 2 (\text{sodium} + \text{potassium in mEq L}) \\ &+ \frac{\text{Glucose in mg/dl}}{18} + \frac{\text{BUN in mg/dl}}{18} \end{aligned}$$

The usual expression employed to denote concentration of electrolytes is mEq/L, 1 mEq being one-hundredth of the equivalent weight which means the weight of the substance in g that is capable of combining or displacing 1 g of hydrogen.

The term, *molality* (also called *molarity*), refers to number of mols in a kg of solvent and a liter of solution, respectively.

The ECF and ICF compartments are normally in osmotic equilibrium except for transient changes. A change in the osmolality of either compartment from the normal (which in case of plasma is 285 to 295 mOsm/kg) results in rapid movement of water across the highly permeable cell membrane to achieve an equilibration of osmolality. As a rule, water flow from a region of low osmolality to that of high osmolality. Since sodium chloride is the principle osmotic agent in ECF, regulation of body water depends on regulation of sodium.

Sodium

It is the principal bulk cation responsible for maintenance of ECF volume. Its distribution in body is shown in Table 16.1.

Regulation of Na⁺ depends upon:

- *Intake* It is frequently related to cultural customs. Salt craving is occasionally encountered in patients with salt-wasting syndromes.

Table 16.1: Distribution of sodium in body

Body components	Percentage of sodium
Exchangeable form	71
Nonexchangeable form	29
Interstitial fluid	29
Plasma fluid	11
Bone	14
Connective tissue	8
Transcellular fluid	2.5
ICF	2.5

- **Absorption** It occurs through GIT, except stomach, being maximum in jejunum. Na^+ binds with glucose in presence of binding proteins and is transported into the cell by the Na^+/K^+ activated ATPase system. Aldosterone augments Na^+ absorption.
- **Excretion** It occurs either through sweat or renal system. Normally, it is 5-10 mEq/L in sweat. In cystic fibrosis and Addison's disease, it is raised. Renal excretion of Na^+ is related to glomerular filtration and tubular reabsorption which, in turn, depend upon renin-angiotensin system and atrial natriuretic peptide.

The kidney is the main organ involved in regulation of water and sodium balance. The main role in regulation of this balance is of ADH, aldosterone and thirst mechanism. In addition atrial natriuretic peptide is produced by the distention (stretching) of the right atrium in CCF leads to loss of water and sodium, thereby cutting down the load on the heart.

Potassium

K^+ is the major intracellular cation. As high as 90% is exchangeable. In ICF, K^+ concentration is around 150 mEq/L whereas it is just around 4 mEq/L in ECF.

Its functions include:

- Excitability of nerve and muscle tissue
- Contractibility of cardiac, skeletal and smooth muscles
- Maintenance of cell volume (intracellular)

It is mainly absorbed from the upper GIT.

Both renal and extrarenal mechanisms play role in regulation of potassium balance as follows:

- Hyperkalemia causes aldosterone production which acts on the distal convoluted tubules, thereby facilitating reabsorption of sodium. This leads to potassium excretion.
- Aldosterone further leads to potassium loss in saliva, sweat and GIT, thereby contributing to potassium homeostasis.
- Hyperkalemia stimulates sodium-potassium-ATPase pump which leads to nonmineralocorticoid-dependent exchange of sodium and potassium at the level of distal convoluted tubules.

Factors promoting potassium movement into the cells include:

- Alkalosis which causes exit of hydrogen ion from the cell and entry of potassium ion into the cell.

- Insulin which enhances potassium uptake by the cell by directly stimulating sodium-potassium-ATPase activity.

Acid-base Balance

An *acid* is a substance that donates a proton (hydrogen ion). A *base*, on the other hand, is a hydrogen ion acceptor. A *buffer* is a substance that reduces the change in free hydrogen ion concentration of a solution when an acid or base is added. *Aprotics* are cations (sodium, potassium, calcium, magnesium) that carry one or more positive charges, or anions (chloride, sulfate) that carry negative charges. They are not capable of either donating or accepting hydrogen ions. Hence, they are not acids, bases or buffers.

It is the concentration of hydrogen ions that determines the acidity of body fluids. If the concentration of hydrogen ion is higher, the fluid is acidic. If the concentration of these ions is less, the fluid is basic or alkaline. In a neutral solution, the number of H and OH ions is equal.

The term *pH* is employed to denote acidity, alkalinity or neutrality. Higher pH means alkalinity and reduced pH acidity. A neutral solution has a pH of 7, blood pH is 7.4 ± 0.05 which means that it is slightly alkaline. Blood pH under 7 and beyond 7.7 is not compatible with life.

Since hydrogen ion concentration is dependent on the ratio of PCO_2 and bicarbonate, pH too is given by this ratio rather than the individual values of the components. If PCO_2 rises by 1 mmHg, pH is lowered by 0.01, if HCO_3^- falls by 1 mEq/L, pH is lowered by 0.02.

Regulation of body pH is by:

- Chemical buffer system in the form of bicarbonate-carbonic acid system (ECF compartment), protein, organic phosphate, hemoglobin (ECF compartment), and phosphate in monohydrogen and dihydrogen forms (urine)
- Pulmonary mechanism which lends support to the bicarbonate-carbonic acid buffer system by eliminating excess CO_2 through rapid breathing

According to Kasires and Bleich equation (which clinically replaces Henderson-Hasselback equation)

$$[\text{H}^+] = 24 +$$

The equation shows that pH depends not on absolute levels of HCO_3^- and PCO_2 but on the ratio of the two concentrations. A decrease or increase in concentration of HCO_3^- does not modify pH if the PCO_2 is lowered or increased in proportion. By altering the rate at which CO_2 is excreted, the lungs can regulate PCO_2 and modify pH.

Thus, an increased respiratory rate, stimulated by increased CO_2 levels increases CO_2 excretion, resulting in reduced PCO_2 and increased pH.

- Renal mechanism by excreting hydrogen ions as phosphate buffer salts and ammonia ions and by reabsorption of bicarbonates in the proximal tubules.

- Renal mechanism

Under normal conditions, renal mechanism is the most important regulator for acid-base balance. It fulfills two requirements, i.e. preventing loss of HCO_3^- in urine and maintaining plasma HCO_3^- levels by excreting an amount of acid equal to daily production of nonvolatile acids and adding new bicarbonates to blood. This is accomplished by reabsorption of nearly all the filtered HCO_3^- , predominantly at the proximal convoluted tubules (80%) and excretion of H^+ ions along with addition of a new HCO_3^- to blood.

Table 16.2 gives the normal values of arterial and venous pH, pCO_2 and HCO_3^- .

Table 16.2: Normal levels of blood pH, pCO_2 and HCO_3^-

Criteria	Blood levels	
	Venous	Arterial
pH	7.35-7.40	7.38-7.45
pCO ₂	45-50 torr	35-45 torr
HCO ₃ ⁻	24-25 mEq/L	23-27 mEq/L

Buffer system is the mechanism provided to resist a significant change in the hydrogen ion concentration of the blood when moderate amounts of acid or base are added to it. Table 16.3 lists the various buffers provided in the body.

The following standard equation (*Henderson-Hasselbach equation*) governs the pH:

$$\text{pH} = \text{pK} (6.1) + \log \frac{\text{Base (Bicarbonate)}}{\text{Acid (Carbonic acid)}}$$

This system enables the body to make up for the various acid-base disturbances and to maintain the blood pH within the normal limits. As for instance, in

Table 16.3: The components of the buffer system provided in the body

- Bicarbonate-carbonic acid buffer: Abundant though weak
- Hemoglobin: Very powerful
- Proteins
- Bicarbonate-carbonic acid in renal tubules
- Monohydrogen phosphate- dihydrogen phosphate buffer
- Sodium-hydrogen exchange in the distal renal tubules
- Ammonia-ammonium buffer in the distal renal tubules

response to respiratory acidosis, kidney tends to retain bicarbonate, thereby resulting in the so-called *compensatory metabolic alkalosis*. On the other hand, in respiratory alkalosis, the kidney responds by eliminating bicarbonate, resulting in *compensatory metabolic acidosis*.

Similarly, metabolic acidosis or alkalosis may be followed by *compensatory respiratory alkalosis* or *acidosis* through increase or decrease in respiratory rate. Respiratory compensation is more rapid and more powerful than the metabolic compensation.

No doubt compensatory mechanism plays an important role in maintaining the pH of blood. What is equally important is the fact that it never overcorrects the underlying acid-base disturbance.

In order to determine the acid-base status of a child, a gadget, *blood gas analyser*, is employed. It measures pH, PCO_2 , and Hb concentration. The remaining indices can be calculated from them.

DISORDERS OF FLUID AND ELECTROLYTE BALANCE

Dehydration

Dehydration is a clinical state that results from loss of body fluids in excess of intake, from fluid deprivation, or from fall in total quantity of electrolytes. In order to restore or maintain the normal volume and composition of body fluids, oral or parenteral fluid therapy is mandatory. Such a therapy consists of three phases, namely *deficit replacement*, *supplemental replacement* and *maintenance*. The topic is discussed at length in Chapter 24.

Hyponatremia

It is defined as a serum sodium of less than 130 mEq/L.

Etiology

It is caused by conditions that lead to:

1. primary sodium deficit with sodium depletion from renal losses, extrarenal losses or nutritional deficits
2. primary water excess with water gain
3. abnormal retention of sodium and water.
For details, see Table 16.4

Table 16.4: Etiology of hyponatremia**Primary sodium deficit with sodium depletion**

Renal sodium losses Prematurity, renal salt wasting. Adrenal insufficiency with mineralocorticoid deficiency, recovery phase of acute tubular necrosis, chronic diuretic therapy, osmotic diuresis in diabetes mellitus, renal tubular acidosis
Extrarenal sodium losses Vomiting, gastroenteritis/diarrhea, nasogastric drainage, excess sweating, burns, cystic fibrosis.
Nutritional deficits Water intoxication (WIC) syndrome, IV fluids poor in sodium, CSF drainage, burns, paracentesis.

Primary water excess with water gain

Syndrome of inappropriate ADH secretion (SIADH), hypothalroidism, excess IV fluids, psychogenic polydipsia, glucocorticoid deficiency, tap-water enema.

Abnormal retention of sodium and water

Nephrotic syndrome, cirrhosis, CCF, renal failure (both acute and chronic)

Clinical Features

These include restlessness, confusion, seizures, hypotension, CCF and coma depending on the severity of hyponatremia. Most subjects with serum sodium under 130 mEq/L but above 120 mEq/L are asymptomatic.

Treatment

Symptomatic hyponatremia is treated by administering 3% solution of sodium chloride (saline), 10 ml/kg (maximum 12 ml/kg) at a rate of 1 ml/minute, intravenously. This would correct hyponatremia by approximately 5 mEq/L. Thereafter, extra sodium needed (calculated as per the formula given below) may be administered slowly spread over 24 to 48 hours. Rapid correction carries the risk of pontine myelinolysis.

Sodium deficit (mEq/L) = [serum Na expected (135) – serum Na (actual) × wt (kg) × 0.6.

In hyponatremia associated with SIADH, water-overloading and renal failure, fluid restriction is required to safeguard against pulmonary edema and CCF. In hyponatremia accompanying hypoproteinaemia, fluids must not be restricted.

Hypernatremia

It is defined as a serum sodium of more than 150 mEq/L.

Etiology

The causes are related to either excessive gain of sodium or excessive loss of water compared to sodium loss (Table 16.5).

Table 16.5: Etiology of hypernatremia**Excessive sodium gain**

Erroneously prepared ORS/formula, accidental substitution of sodium chloride for glucose in infant formula, excessive sodium bicarbonate during resuscitation, IV administration of hypertonic saline, sea-water ingestion, hypernatremic enema, Munchausen by proxy syndrome involving intentional salt poisoning, high breastmilk sodium.

Intentional water loss/deficit

Diabetes insipidus (both central and nephrogenic), diabetes mellitus, AGE with water loss more than solute loss, inadequate breastfeeding, poor water intake, prematurity accompanied by increased insensible water loss, adipisia, inadequate excess to free water

Clinical Features

These include tough and doughy skin and subcutaneous tissue, and, irritability, confusion, twitching and, seizures. Subdural, subarachnoid and intracerebral hemorrhages may occur. Associated metabolic acidosis may cause deep rapid breathing.

Treatment

- If the child is conscious, he is treated with ORS over and above continuation of breastfeeding and enough of water.
- If the child is in shock, give IV Ringer's lactate or NaCl to correct hypovolemia.
- Treat the underlying cause.
- Ensure slow correction of hypernatremia, not more than 0.5 mEq/L/hour or 10 mEq/L/day fall.
- The goal is to bring the serum sodium to 145 mEq/L.
- If serum sodium is over 180 mEq/L, peritoneal dialysis is indicated.
- In case of development of convulsions during treatment, (usually because of water intoxication), it is advisable to give 3-5 ml/kg of NaCl or 20% mannitol.
- Correct hypocalcemia.

Hypokalemia

It is defined as a serum potassium level of less than 3.5 mEq/L.

Etiology

Hypokalemia may result from reduced intake, renal losses, extrarenal losses, and fall in muscle mass (Table 16.6).

Table 16.6: Etiology of hypokalemia	
Reduced potassium intake	Protein-energy malnutrition
High renal losses	<i>Diuretics</i> Osmotic diuretics, carbonic anhydrase inhibitors
	<i>Tubular defects</i> Renal tubular acidosis
	<i>Acid-base disturbances</i> Diabetic ketoacidosis, alkalosis
	<i>Endocrinopathies:</i> Cushing syndrome, primary aldosteronism, thyrotoxicosis
High extrarenal losses	<i>GIT</i> Diarrhea, vomiting, catharsis, frequent enemas, biliary drainage, enterocutaneous fistulas
	<i>Skin</i> Profuse sweating
Miscellaneous	<i>Decrease in muscle mass</i> Myopathies
	Familial hypokalemic periodic paralysis

Clinical Features

These include weakness of skeletal muscles, hypotonia, hyporeflexia, abdominal distention, poor peristalsis, paralytic ileus, frank paralysis and considerable respiratory distress.

Prolonged hypokalemia leads to inability of kidneys to concentrate urine, polyuria, polydipsia and alkalosis. Poor renal function may persist even after correction of hypokalemia.

Cardiac involvement may be in the form of arrhythmias and ECG changes which include depression of ST segment, flattening or inversion of T wave, prominent U wave and prolongation of QTc beyond 0.425 sec. Yet severe hypokalemia may further cause prolonged P-R interval, sino-atrial block and extrasystoles (ventricular). Mental apathy may also be encountered.

Treatment

It consists in administering potassium 2 to 3 mEq/ kg/ 24 hour, over 24 hours. The IV fluid must not contain more than 40 mEq/L potassium.

Hypokalemia with massive urinary losses should be treated with oral potassium, 10 mEq/kg. Indomethacin and MgCl₂ are indicated in Barter syndrome and Gitelman syndrome, respectively.

Hyperkalemia

It is defined as a serum potassium of more than 5.5 mEq/L.

Etiology

It usually results from excessive intake (often through IV fluids), impaired excretion (acute/chronic renal failure, adrenal insufficiency, hyporeninemic hypoaldosteronism, potassium-sparing diuretics), shifting or release of potassium from tissues into ECF (acidosis, injury, hemorrhage, burns, hemolysis, insulin deficiency) and drugs (succinyl-choline, digitalis toxicity).

Clinical Features

Significant hyperkalemia may cause marked muscular weakness with flaccid paralysis, tetany, paresthesia, bradycardia, shock and cardiac arrhythmias. ECG changes include elevation and tenting of T-wave, widening of QRS complex, depression of ST segment, prolongation of PR interval and short QT interval.

Treatment

Initial therapy consists in rapid IV administration of sodium bicarbonate, 1 to 3 mEq/kg, or glucose and insulin (0.5 to 1 g of 10 to 20% glucose/kg plus 1 unit crystalline insulin/3 g of glucose) to lower the serum potassium level, and IV calcium gluconate, 0.3 to 0.5 ml/kg of a 10% solution, slowly to counter the cardiac toxicity. It would be under ECG monitoring.

Eventually, a negative potassium balance is attained by employing ion-exchange resins, e.g. kayexalate, 1 g/kg/24 hr (orally or as retention enema) in 2 to 4 divided doses, by hemodialysis, or by peritoneal dialysis.

DISTURBANCES OF ACID-BASE BALANCE

Metabolic Acidosis/Acidemia

Metabolic acidosis means accumulation of acid whereas *metabolic acidemia* means actual lowering of blood pH because of elevation of hydrogen ion concentration

1 above normal. The former need not necessarily be accompanied by the latter because the accumulation of acid might have been tackled well by the buffer defense mechanism or the compensatory respiratory mechanism.

Etiology

Two categories depending on the elevation or normality of the anion gap (difference between sum-total of cations, sodium and potassium, and sum-total of anions, chloride and bicarbonate; normal up to 16 mEq/L; high is associated with severe illness and greater mortality).

Metabolic acidosis associated with an elevated anion gap results from overproduction of endogenous acids (ketoacids in ketoacidosis, or lactic acidosis), underexcretion of fixed acids (advanced renal failure), or ingestion of excess exogenous acids (salicylates, alcohol).

Metabolic acidosis associated with a normal anion gap (hyperchloremia) results from net loss of bicarbonate from the kidney (renal tubular acidosis, nephrotoxin-related) or GIT (severe diarrhea).

Clinical Features

Manifestations in mild metabolic acidosis may be in the form of nausea, vomiting, headache and abdominal pain. In chronic acidosis, there may be fatigue and anorexia.

In significant metabolic acidosis (pH < 7.2), respiration becomes deep and rapid (Kussmaul breathing) and the child becomes drowsy, confused and stuporous. In severe acidosis, peripheral vasodilation, vascular collapse and shock may follow. Often, hyperkalemia may accompany it.

Treatment

Severe metabolic acidosis (pH < 7.2) is countered by administration of sodium bicarbonate, 1 to 2 mEq/kg, or, preferably as given by the following formula: Sodium bicarbonate (mEq) = Bicarbonate deficit (mEq/L) × body weight (kg) × 0.3

Half of the calculated sodium bicarbonate should be given immediately and the remaining half as an infusion in 12 to 24 hours period. The usually available 7.5% solution providing 0.9 mEq/ml of bicarbonate needs to be diluted in an equal volume of distilled water (alternatively, double volume of 5% dextrose).

In addition to management of underlying condition such as diabetes mellitus, simultaneous administration of potassium to safeguard against risk of development of hypokalemia is strongly recommended. Calcium gluconate is indicated if the subject develops hypocalcemic tetany following correction of metabolic acidosis.

In case of severe acidosis with hypernatremia, it is advisable to substitute sodium bicarbonate by tris-hydroxymethyl-aminomethane (THAM).

Metabolic Alkalosis/Alkalemia

Etiology

It is caused by either administration of large amounts of alkali, IV or orally (milk alkali syndrome), by loss of hydrogen ions (vomiting in hypertrophic pyloric stenosis, prolonged gastric aspiration), or by acute volume contraction with disproportionate losses of chloride.

Severe hypokalemia causes metabolic alkalosis by shifting hydrogen ions into the cells.

Aldosteronism, Barter syndrome and Cushing syndrome may cause saline-resistant alkalosis, i.e. alkalosis without volume and chloride depletion.

Clinical Features

These include hypoventilation, apathy, confusion, drowsiness, stupor and coma. In addition, alkanotic tetany due to low ionic calcium and cardiac arrhythmias due to hypokalemia may occur.

Treatment

Treatment is indicated only in cases of severe metabolic alkalosis with a pH over 7.5. Most cases respond to administration of saline (isotonic or 1/2 isotonic) infusion with added potassium.

Ammonium chloride or arginine hydrochloride infusion is indicated in cases of severe alkalosis resistant to saline, usually following massive loss of gastric contents.

Severe alkalosis in association with renal failure or hyperosmolar state is an indication for hemo- or peritoneal dialysis.

Respiratory Acidosis/Acidemia

It means marked reduction in blood pH primarily as a result of retention of carbon dioxide from poor ventilation.

Etiology

Acute respiratory acidosis may follow airway obstruction (bronchial asthma, foreign body, laryngeal edema, croup, aspiration), lung diseases (respiratory distress syndrome in the newborn, pneumonias, pneumothorax, pulmonary edema, pulmonary embolism), neuromuscular diseases (Guillain-Barré syndrome, poliomyelitis), brainstem lesions with central depression, oversedation (opium) and child abuse.

Chronic respiratory acidosis may be associated with chronic lung disease like asthma, cystic fibrosis, bronchiectasis, interstitial fibrosis, kyphoscoliosis, Werdnig-Hoffmann disease, etc.

Treatment

It consists in treating the underlying etiologic factor(s) and improving alveolar gas exchange by assisted ventilation rather than by IV sodium bicarbonate which may prove counterproductive by causing hyperosmolality and CCF.

Respiratory Alkalosis/Alkalemia

Etiology

It results from salicylate intoxication, hyperventilation (hysterical, assisted ventilation on a respirator), CNS disorders (severe hypoxia, trauma, infection, tumors), CCF, hepatic insufficiency and septicemia.

Clinical Features

These include numbness, tingling, paresthesia, light-headedness, and, in severe cases, tetany. At times, unconsciousness may result from vasospasm of cerebral vessels because of hypercapnia.

Treatment

It is aimed at correcting the underlying cause. Acidifying agents (ammonium chloride) are not indicated.

Mixed Acid-base Disturbances

The following four types of mixed acid-base disturbances may also be encountered:

1. Respiratory acidosis—metabolic acidosis (e.g. respiratory distress syndrome)
2. Respiratory acidosis—metabolic alkalosis (e.g. following use of excessive diuretic therapy in chronic respiratory acidosis in subjects with CCF)
3. Metabolic acidosis—respiratory alkalosis (e.g. hepatic failure)
4. Metabolic acidosis—respiratory alkalosis.

One should suspect a mixed acid-base disturbance when the compensatory response falls outside the expected range.

PRINCIPLES OF FLUID AND ELECTROLYTE THERAPY

Deficit Therapy

It is mandatory to ascertain the pre-existing deficit i.e. losses as in acute gastroenteritis/acute diarrhea and correct it as early as possible. Though it is best calculated based on weight loss, in practice (since baseline weight is usually not known), it is assessed on the bases of clinical signs such as sensorium, thirst, dryness of mucous membrane, anterior fontanel/sunken eyes. Therapy needs to be by fluid, similar in composition and amount.

Maintenance Therapy

A relationship exists between child's weight and his daily energy and fluid requirements. On an average, fluid requirement is 100 ml/100 kcal/day. Simultaneous needs for sodium = 1-3 mEq/100 ml kcal and potassium = 1-2 mEq/100 kcal/day. A 5% dextrose assists in providing not only energy but also safeguarding from ketosis and gross tissue catabolism. Isolyte P meets these conditions. It provides N/5 (0.18%) sodium chloride, 5% glucose and 20 mEq/L of potassium chloride.

Replacement of Ongoing Losses

It is important to replace the ongoing losses (vomiting, diarrhea, suction, aspiration) by fluids that are similar in composition and volume.

FLUID THERAPY IN SPECIAL SITUATIONS

Diarrheal Dehydration

See Chapter 24 (Pediatric Gastroenterology).

Malnutrition

The characteristic features of dehydration accompanying PEM are:

1. It is difficult to evaluate it because of pre-existing loss of subcutaneous fat in marasmus and presence of edema in kwashiorkor
2. It has a tendency to be "hypertonic" with low potassium

ORS is the therapy of choice in mild-moderate dehydration in PEM. In order to provide less sodium

and more potassium, a special “rehydration solution for severely malnourished child” (ReSoMal) is recommended by the WHO (Table 16.7). It may be prepared by dissolving a pack of standard ORS in 2 liters rather than 1 liter of water and adding sucrose 50 g and mineral mix solution 50 g.

Table 16.7: Composition of ReSoMal compared to standard ORS and hypoosmolar ORS (mmol/L)

	ReSoMal	Standard ORS	Hypoosmolar ORS
Sodium	45	90	
Potassium	40	20	
Chloride	70	80	
Citrate	7	10	
Magnesium	3	–	
Zinc	0.3	–	
Copper	0.045		
Total osmolarity	300	311	

Recommended regimen for ReSoMal is 75-100 ml/kg in 12 hours. It may be given orally or through nasogastric tube.

Intravenous fluid therapy is usually needed in severe dehydration in malnourished child:

- Initially, Ringer lactate or N/2 saline in 5% dextrose, 30 ml/kg in 2 hours
- Then, N/6 saline in 5% dextrose, 100 ml/kg in next 10 hours
- N/6 saline in 5% dextrose at half the rate in subsequent 12 hours
- Maintenance fluid, 75 ml/kg/day, may be continued until feeding is established
- It is advisable to add potassium to IV fluid after the child has passed urine.

Acute Renal Failure (ARF)

In order to be sure if the ARF is prerenal or intrinsic, “fluid challenge” is warranted. For this, a bolus of normal saline (which is similar to ECF) is given rapidly in a dose of 10 ml/kg. In prerenal ARF, higher urine output > 1 ml/kg/hour follows. If the challenge turns out to be negative, another bolus of IV infusion along with frusemide, 2 mg/kg. If this too fails to increase the urine output, the diagnosis of intrinsic ARF stands confirmed.

Management of intrinsic ARF revolves round restriction of fluid intake to insensible losses plus preceding day’s urine output. The recommended fluid is plain dextrose (which is electrolyte-free), around 45-

55 ml/kg/day (insensible losses 45 ml + urine output 10 ml/kg/day).

Congestive Cardiac Failure (CCF)

The characteristic features of CCF are:

1. Fluid overload which demands fluid restriction to 2/3rd of the normal requirement.
2. Hyponatremia from dilution and diuretic losses which does not demand increased sodium intake in view of the risk of worsening CCF.
3. Hypokalemia from diuretic usage/losses which demands correction.

The recommended maintenance fluid is 70 ml/kg/day N/5 in 5% dextrose with 2 ml KCl/100 ml. This provides restriction to 2/3rd volume with extra potassium but normal sodium. See Chapter 22 (Pediatric Cardiology).

Intestinal Obstruction

The gastric juice contain around 60 mEq/L sodium, 10 mEq/L potassium and 85 mEq/L chloride. The ileal fluid contains over double sodium (130 mEq/L), same potassium (10 mEq/L) and more chloride(115 mEq/L).

It is important to reduce the increasing abdominal distention by decompressing the stomach via an indwelling nasogastric tube. N/2 or N/3 saline (plus potassium) should be employed to replace the nasogastric aspirate, volume for volume.

In case of an ileostomy, subsequent losses should be replaced with Ringer lactate (volume for volume).

FURTHER READING

Articles/Chapters

1. Gennari FJ: Hypokalemia. *New Engl J Med* 1998;339:451.
2. Greenbaum LA: Pathophysiology of body fluids and fluid therapy. In: Kliegman RM, Behrman RE, Jenson HB stanton BF (eds) Nelson Textbook of Pediatrics, 18th edn. Philadelphia: Saunders 2008:191.
3. Logan RW: Fluid, electrolyte and acid-base disturbances. In: Campbell AGM, McIntosh N (eds) *Forfar and Arneil's Textbook of Pediatrics*, 4th edn. London: ELBS with Churchill Living-stone 1992:469.
4. Mengi Y, Digra NC, Goswamy HL. Fluid and electrolyte therapy in surgical child. In: Gupte S (ed): *Recent Advances in Pediatrics-13*. New Delhi: Jaypee 2003: 316.

Book/Monograph

1. Finberg L, Kravath RE, Hellerstein S. *Water and Electrolytes in Pediatrics*, 2nd edn. Philadelphia: Sainders 1993.

PART TWO

Neonatology



INTRODUCTION

First four weeks of life after birth are described as newborn period. Proper care of the newborn babies forms the foundation for the subsequent life not only in terms of longevity or survival but also in terms of qualitative outcome without any mental and physical disabilities.

IMPORTANCE OF THE NEONATAL CARE

Infant mortality rate (IMR), i.e. number of children less than 12 months or one year of age dying per 1000 live births per year, is a very sensitive indicator of the socioeconomic development including the status of health care of any country. IMR has two distinct components.

- The neonatal mortality (deaths during the first four weeks or one month of life)
- The postneonatal mortality (deaths after one month of age upto 12 months of age)

Due to several measures like Universal Immunization Program, use of ORS and Diarrheal Diseases Control Program, Acute Respiratory Infections (ARI) Control Program, etc., India has achieved considerable reduction in IMR which at present is around 55. But the reduction is mainly in the postneonatal period. During neonatal period, excepting reduction in neonatal tetanus, achievement has not been up to the mark.

Between 1972 and 2008, the postneonatal mortality has declined by 70 percent whereas neonatal mortality has dropped only by 38 percent.

Currently IMR at national level is around 55 per 1000 live births whereas NMR is 40 per 1000 live births.

Thus NMR constitutes about 65% of IMR. For achieving further reduction in IMR, it is imperative that we take urgent measures to reduce NMR.

NOMENCLATURE/DEFINITIONS RELATED TO PERINATAL/NEONATAL PERIOD

Box 17.1 lists the noteworthy definitions concerning the neonate.

Box 17.1: Noteworthy definitions in relation to the neonate

Neonatal period: First 28 days after birth

Early neonatal period: First 7 days of life

Late neonatal period: > 7th to 28 days of life

Perinatal period: From 28th week of gestation (or over 1000 g of birth weight) to 7th day of life.

Extended perinatal period: From 22nd week of gestation (or over 500 grams of birth weight) to 7th day of life.

Term baby: Neonate born between 37 weeks (completed) and 42 weeks (completed) of pregnancy, irrespective of the birth weight.

Preterm baby: Neonate born before 37 weeks (completed) or <259 days irrespective of birth weight.

Post-term baby: Neonate born after 42 weeks (completed) or >294 days irrespective of birth weight.

Low birth weight (LBW): Birth weight <2500 g, irrespective of gestational age.

Very low birth weight (VLBW): Birth weight <1500 g, irrespective of gestational age.

Extremely low birth weight (ELBW): Birth weight <1000 g, irrespective of gestational age.

Small for gestational age (SGA) or Small for date (SFD): Birth weight < 10th percentile for that period of gestation.

Large for gestational age (LGA) or Large for date (LFD): Birth weight > 90th percentile for that period of gestation.

Contd...

Contd...

Appropriate for gestational age (AGA): Birth weight between 10th and 90th percentile for that period of gestation.

Neonatal mortality rate: Defined as neonatal deaths of infants weighing above 1000 grams during first 28 days after birth per 1000 live births.

Perinatal mortality rate (PMR): Defined as late fetal deaths plus early neonatal deaths of neonates weighing above 1000 g at birth or of at least 28 weeks of gestation per 1000 total births (both live and still births) weighing over 1000 g (sometimes calculated per 1000 live births).

Extended perinatal mortality rate (EPMR): Defined as fetal deaths from 22 weeks of gestation (or more than 500 gram weight) and early neonatal deaths per 1000 deliveries (or 1000 live births)

Early neonatal mortality rate (ENMR): Defined as neonatal deaths of infants weighing more than 1000 g during the first seven days of birth per 1000 live births.

Late neonatal mortality rate (LNMR): Defined as neonatal deaths of infants weighing >1000 grams at birth during 2nd to 4th week of life for 1000 live births.

Live born: Product of conception that shows an evidence of life (breathing, heart beat, pulsation of umbilical cord or definite movements of voluntary muscles) after separation from the mother.

Still born: (late fetal death) is a product of conception that fails to show an evidence of life, (breathing, heart beat, pulsation of umbilical cord or definite movements of voluntary muscles) , provided that gestational age is 20 weeks or more or weight exceeds 500 grams. Such a baby is expected to have been alive *in utero* and died during passage through the birth canal.

- Hypertension, diabetes mellitus, thyrotoxicosis, heart disease and other systemic illnesses.

Examples of secondary factors are:

- Maternal infections
- Multiple pregnancy, especially second of twins
- Breech presentation, unstable lie and other abnormal presentations
- Cord presentation
- Pregnancy-induced hypertension
- Toxemias
- Rh isoimmunization
- Poor fetal growth
- APH
- Hydramnios
- Cephalopelvic disproportion
- Fetal distress as indicated by exaggerated fetal movements, slow and irregular heart rate and visceral overactivity in the form of passage of meconium
- Prolonged rupture of membranes (PRM)
- Early onset of labor.

All these high-risk factors during pregnancy and labor are pointers that the staff must be prepared to receive an asphyxiated neonate with availability of a well-trained pediatrician for resuscitation, including endotracheal intubation, if the need be. Also see heading "Neonatal Resuscitation" later in this very chapter.

NEONATAL AND PERINATAL MORTALITY IN INDIA

Current NMR in India is around 40 per 1000 live births. There are state to state variations within the country. Almost 50% of neonatal deaths occur within first one week life and majority of them within the first 24 hours of life.

Neonatal mortality is directly related to birth weight and gestational age of the infant. Low birth weight is a major determinant of neonatal mortality. Almost 75% mortality due to various causes occurs amongst low birth weight infants. The leading causes of neonatal mortality in India are neonatal septicemia (52%) birth asphyxia (20%) and prematurity (15%). Congenital malformations also contribute some significant proportion of neonatal deaths (3 to 5%). Until a recently, tetanus neonatorum was the leading cause of neonatal deaths in India. Now, barring a few pockets, it has been virtually eradicated from most parts of India.

HIGH-RISK PREGNANCY

A high-risk pregnancy is defined as the one in which the mother is suffering from either a preconceptional adverse factor or an adverse factor becomes evident during the course of the pregnancy.

Examples of preconceptional or primary factors are:

- Poor socioeconomic background
- Maternal malnutrition with weight under 40 kg, height under 145 cm and hemoglobin under 8 g%.
- Maternal age of less than 20 years (the so-called "teenage pregnancy") or over 35 years.
- Primigravida
- Grand multipara
- Bad obstetric history with abortions, stillbirths difficult or operative deliveries, perinatal deaths, LBW, congenital malformations
- Rh negative mother

Current PMR in India is around 30 per 1000 live births. Stillbirths are almost equal to that of early neonatal deaths.

Etiology

Various overlapping factors seem to be responsible for perinatal deaths (Table 17.1).

Table 17.1: Factors responsible for perinatal mortality

Antenatal

Maternal malnutrition, anemias, toxemias of pregnancy, twinning, diabetes mellitus, hypertension, chronic glomerulonephritis, ante-partum hemorrhage, hemolytic disease, drugs

Perinatal

Birth trauma, anoxia, hemorrhage

Postnatal

Low birth weight, preterm birth, respiratory distress, hemorrhagic disease, hemolytic disease, septicemia and other infections, congenital anomalies not compatible with life.

Strategy to Reduce Perinatal Mortality

Prevention of Birth Hypoxia/Trauma

Early recognition of fetal hypoxia, which should indeed be anticipated in a high-risk pregnancy, and prompt action to combat it are of paramount importance.

Prevention of Low Birth Weight

Perinatal mortality is some 50-folds higher in LBW infants than in normal neonates, former accounting for 75% of all neonatal deaths. Health and nutrition education of the target female population, adequate training of the trained birth attendants (TBAs) in the art of effective perinatal care with ability to recognize and refer the high-risk cases to a reasonable center and provision of Level 2 nonatal facilities at all district and maternity hospitals are urgently needed.

Good antenatal care with minimum two ultrasonographic assessments during pregnancy is likely to identify IUGR and, therefore, contribute to reduction in incidence of LBW infants.

Recently, there has been growing appreciation of the problem of teenage pregnancy as a significant factor in perinatal mortality.

Prevention of Neonatal Infections

This may be attained by the following measures:

1. Barrier technique in the nursery

Table 17.2: Perinatal risk scores

Risk factors	Scores
1. Foul-smelling liquor	2
2. Unclean vaginal examination	2
3. 1-minute Apgar scores 0 to 6	2
4. Prolonged labor (over 24 hours)	2
5. Prolonged rupture of membranes (PRM) beyond 24 hours	1
6. Prematurity/birth weight 2 kg or less	1
Total	10

Note: After calculating the total score in a given case, categorization is done as follows:

Scores	Probability of infection
0 to 3	less than 1%
4 to 5	About 17%
6 to 10	over 50%

It is suggested that all neonates above score 3 be screened for infection. In case of a score exceeding 5, antibiotic therapy must seriously be considered

2. Minimal handling and handwashing by the staff/ attendants.
3. Colonization of the neonate
4. Cleaning of the nursery
5. Cleaning and disinfection of the nursery equipment
6. Surveillance of nursery flora, especially at the time of outbreak of an infection
7. Screening of referred neonates
8. Active immunization of mothers during pregnancy against tetanus
9. Antibiotic prophylaxis.

For details on points 1 to 7, see Chapter 13.

Prophylactic antibiotics are strongly indicated in situations where there is a reasonable doubt of infection. A perinatal risk scoring system (Table 17.2) may be of considerable value for the guidelines in this respect.

Prevention of Congenital Malformations

This can be, to some extent, attained by such measures as avoidance of consanguinous unions, promotion of rubella vaccine for all girls before they get married, avoidance of irradiation and medication, drug abuse, alcohol, smoking during pregnancy, discouraging active reproduction after the age of 35 years, etc.

Prevention of Rh Incompatibility

This may be achieved by avoiding incompatible unions (a very difficult task in a country such as ours where

the priest rather than logic and reasoning operate considerably in deciding the marriages), or administering prophylactic injection of anti-D immunoglobulins in the following situations:

- After each Rh positive abortion
- After each Rh positive birth

The injection requires to be given within 72 hours of delivery/abortion.

It may be appropriate to administer anti-D immunoglobulins antenatally during 28th week to Rh negative mothers with Rh positive husbands since in 2% cases sensitization can occur before birth.

BIRTH TRAUMA

Birth trauma can cause fracture of skull, clavicle and extremities and various paralysis such as *Erb paralysis* (due to involvement of fifth and sixth cervical roots) (Fig. 17.1), *Klumpke paralysis* (due to involvement of eighth cervical and first thoracic roots with or without injury to cervical sympathetic plexus) and facial palsy (due to seventh nerve paralysis) (Fig. 17.2). Breech extraction may cause fracture of a long bone (Fig. 17.3). Sternomastoid tumor may occur in difficult breech deliveries in particular. For its details, see Chapter 24.

Whereas intracranial hemorrhage is a serious condition, **cephalhematoma** is rather benign, self-limiting and resolves in a few weeks time. The swelling is nonpulsatile, does not increase in size on crying, and does not cross a suture line (Figs 17.4 and 17.5). The most common site is the parietal or occipital bone. It needs no treatment.

Caput succedaneum consists of serosanguinous fluid collection over the presenting part between the pericranium and the scalp tissue. It is present at birth, crosses the suture line and disappears within a few hours to a day or so (Fig. 17.5).

CONGENITAL AND OTHER DEFECTS

A variety of malformations (Figs 17.6 to 17.17) may occur. The newborn's survival may be in danger because of congenital defects like heart disease, choanal atresia, omphalocele (bowel and other viscera herniating through a defect in the abdominal wall), diaphragmatic hernia, tracheoesophageal fistula (TOF), intestinal obstruction, anorectal anomalies, Pierre Robin syndrome (micrognathia, i.e. a small mandible, cleft palate and posterior displacement of

tongue) and neural tube defects such as meningomyelocele (spina bifida with herniation of meninges, nerve roots and spinal cord) (Figs 17.8 to 17.16). Immediate recognition of such anomalies is important. These conditions are discussed elsewhere in different chapters.

A careful examination may also help in recognizing diseases such as cretinism, Cushing syndrome, Down syndrome and Turner syndrome right at birth.

NEONATAL RESUSCITATION

Resuscitation of the newborn is a real emergency, requiring participation of every one in the labor/delivery room. The fact that 70% of the babies with absent heart beat can be resuscitated shows how rewarding the maneuver is. Often a good antenatal check-up indicates whether resuscitation is likely to be needed. A weak fetal heart of less than 100 beats/minute or its irregularity during the late stage of labor is a sign of progressive asphyxia that will need resuscitative measures.

Today, globally, the trend is to follow the Neonatal Resuscitation Program (NRP) based on the 2005 American Heart Association (AHA) Guidelines which are duly endorsed by the International Liaison Committee on Resuscitation. In India, The National Neonatology Forum (NNF) and the Indian Academy of Pediatrics are propagating these guidelines through Neonatal Advanced Life Support (NALS) Course workshops across the country.

High-risk Situation

- A. *Maternal*: The situations have already been listed under the heading "High-risk Pregnancy" in this very Chapter.
- B. *Fetal*: Preterm birth, LBW infants, multiple pregnancies, fetal malformations (identified on ultrasonography), IUGR, fetal distress manifested by certain signs (meconium-stained liquor amnii, abnormal variation in fetal heart rate or rhythm, ECG changes in fetal monitoring records, changes in fetal blood pH and gases on fetal blood samples).

Resuscitation Equipment

It should be obligatory on the part of each and every delivery room to maintain an easily accessible neonatal resuscitation tray which is crosschecked and replenished from time to time (Box 17.2).



Fig. 17.1: *Erb paralysis*. Note the characteristic position of the left arm which is adducted and internally rotated with pronation of the forearm. The cause is injury to the 5th and 6th cervical nerves



Fig 17.3: Fracture of the left femur following breech delivery



Fig.17.2: *Facial palsy*. There was h/o birth trauma



Fig 17.4: *Cephalhematoma*. The lesion is soft and fluctuating. It does not cross the suture lines

Adequate Preparation for Resuscitation

Every delivery warrants availability of:

- A radiant warmer ready for use

- All resuscitation equipment immediately available and in good working order
- At least one trained person (preferably two) skilled in neonatal resuscitation

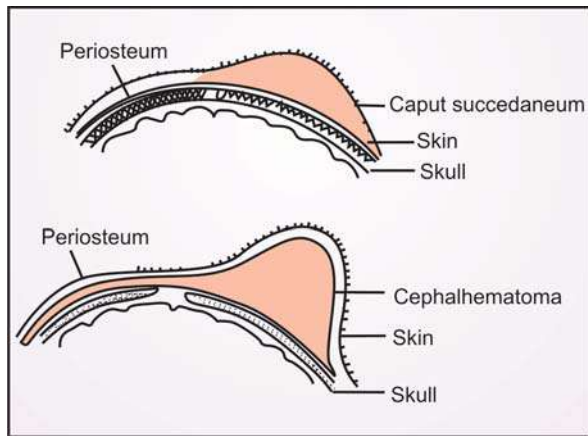

Fig. 17.5: Development of caput succedaneum and cephalhematoma. *Caput succedaneum*: serosanguinous fluid collection in the soft tissue, not limited by suture lines, disappears speedily. *Cephalhematoma*: Collection is blood, between skull bone and overlying pericranium, limited by suture line; disappears slowly in a few weeks



Fig. 17.7: Extroversion of cloaca



Fig. 17.6: *Dysmorphic facies*. Note the remarkably depressed bridge of nose

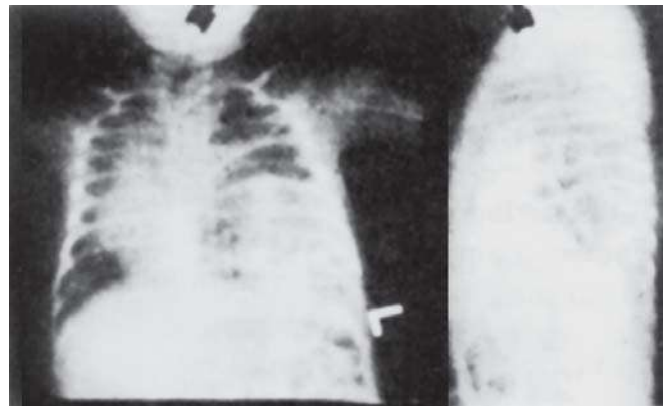

Fig. 17.8: Congenital diaphragmatic hernia



Fig. 17.9: Pierre Robin syndrome. Note the shrewlike facies due to hypoplastic mandible (micrognathia), glossoptosis and high-arched cleft palate

ABC of Resuscitation

Maintenance of Temperature is achieved by:

- Placing the neonate under a preheated radiator warmer or, alternatively, overhead 200 Watt bulb/ room heater.
- Drying the neonate as soon as he is placed under the warmer using a prewarmed towel.
- Removing the wet towel and replacing it with a dry and prewarmed one.



Fig. 17.10: Frontal encephalocele. The sac contains both meninges and brain in about 2/3rd patients with encephalocele, there is accompanying hydrocephalus that may be detected only on CT scan



Fig. 17.12: Occipital encephalocele. It needs to be differentiated from cranial meningocele by palpation, transillumination, and, if needed, CT scan



Fig. 17.11: Occipital encephalocele. The swelling fluctuates in size with coughing or crying which alter the intracranial pressure. Note that this stillborn baby also had anencephaly and hemicrania, the defects that are known to be incompatible with life

Over and above the maintenance of temperature, the major steps in neonatal resuscitation follow the time-honored ABC (airway, breathing, circulation) pattern and should be completed as far as possible within 15 seconds of birth.

A. *Airway:* Anticipate and establish an open airway by:

- positioning of the neonate
- suction of mouth, nose and, at times, trachea
- performing endotracheal intubation and aspiration



Fig. 17.13: Microcephaly with herniation of brain tissue

- B. *Breathing:* Initiate breathing using:
- tactile stimulation, such as slapping the foot, rubbing the back, etc. or
 - positive pressure ventilation (PPV) with a bag and mask or through an endotracheal tube
- C. *Circulation:* Maintain the circulation with:
- chest compression and
 - medications, if needed.

Opening the Airway

Positioning The neonate should be placed on his back/ side with the neck slightly extended to straighten the



Fig. 17.14: Anencephaly. In this infant, who died within 24 hours of birth, membranous skull as well as cerebral hemisphere were absent



Fig. 17.16: *Meningomyelocele*. A relatively higher site, poor transillumination and neurologic deficit are the hallmarks of this anomaly



Fig. 17.15: *Meningocele*. The swelling, containing primarily meningeal tissue, shows good transillumination and no significant functional disability. In order to safeguard against infection and perforation, immediate surgical excision is recommended



Fig. 17.17: Abnormal tuft of hair in an infant with radiologically proven underlying spina bifida occulta. Besides "hair tuft", other conditions that should arouse suspicion of spina bifida occulta include telangiectasia and subcutaneous lipoma. The anomaly is most common at L5 and S1 but it may involve any portion of the vertebral column

airway and head kept slightly down to prevent aspiration with a shoulder roll made out of a towel or a blanket.

Suction If no meconium is present, first the mouth and oropharynx and then the nose and nasopharynx should be gently suctioned. If there is

meconium-stained amniotic fluid, suction should be done when head is delivered but shoulders are yet to be out. This is termed "intrapartum suctioning". After the delivery of the infant, residual meconium in the hypopharynx should be suctioned out under direct vision laryngoscopy.

Box 17.2: Checklist of neonatal resuscitation equipment and supplies

For Suction: Mucus aspirator, meconium aspirator, mechanical suction, suction catheters 10 F or 12 F, feeding tube 6 F, 20 ml syringe

For Bag and Mask Ventilation: Neonatal resuscitation bag, face masks (full-term and preterm sizes), oxygen with flowmeter and tubing

For Endotracheal Intubation: Endotracheal tubes 2.5, 3.0, 3.5, 4.0 and 1 D, laryngoscope with straight blades of size 0 (preterm) and 1 (term) with extra batteries and bulbs for laryngoscopy, stylet, scissors

Medications: Epinephrine, normal saline, sodium bicarbonate, naloxone, sterile water

Miscellaneous: Radiant warmer, umbilical catheters, watch with seconds hand, linen and shoulder roll, stethoscope, adhesive tape, syringes 1 to 50 ml, gauze, 3-way stopcock, gloves

Endotracheal intubation It is done after the baby is delivered to remove secretions from the lower airway. It is indicated in all babies who are depressed and meconium stained (Box 17.3 and Figs 17.18 to 17.20).

Initiating Breathing

Tactile stimulation If the depressed baby fails to have respiration despite drying and suctioning, additional tactile stimulation may be provided by slapping or flicking the soles of the feet and rubbing the back firmly once or twice.

Positive pressure ventilation (PPV) If the baby is still depressed (apnea, heart rate < 100/minute, he should be administered free-flow oxygen (bag and mask ventilation) as per (Box 17.4). If it fails, endotracheal intubation should be performed.

Maintaining Circulation

Chest compression (external cardiac massage) If heart rate remains <60/min It consists of rhythmic compressions (120/min; ratio 3:1) of lower third of the sternum that compress the heart against the spine, raise the intrathoracic pressure and circulate blood to the vital organs. Details are given in Box 17.5.

Medication is only rarely needed. Depressed neonates with heart rate remaining <60/min despite adequate ventilation with 100% oxygen, air-oxygen mixture, or room air (the last two may be preferred) and chest compressions are candidates for receiving medication in the form of epinephrine, volume

Box 17.3: Endotracheal intubation

Indications (1) Failure of bag and mask ventilation as well as medication, (2) When PPPV is needed, (3) When tracheal suction, especial for aspiration of meconium, is needed, (4) Diaphragmatic hernia.

Equipment Endotracheal tube of appropriate size, neonatal laryngoscope with straight blades of size 0 for preterms and 1 for term babies.

Procedure The newborn is placed on a resuscitation table (high enough and with flat surface) in a supine position with fully extended neck at the edge of the table. It is good to place folded towel or blanket beneath the shoulders to facilitate this position. The operator sits on a stool at the head end. As he opens the infant's mouth with the index finger and the thumb of the right hand, his left hand introduces the lighted laryngoscope (infant size) into the nasopharynx up to the epiglottis. The glottis is cleared by gentle suction. This makes it easier to clearly see the epiglottis and the surrounding structures. When the glottis is visible, a curved endotracheal tube is gently inserted through the larynx. Make sure that it is not pushed too far to prevent its entry into the right bronchus. The laryngoscope is now withdrawn. The intermittent positive pressure respiration (IPPR) is given through the tube either by simply puffing in air from operator's mouth or with a bag or mechanical respirator. As soon as respiration gets established, the tube should be withdrawn. If the response is poor, still efforts have got to be continued as long as the heart beat exists.

Precautions during intubation In order to prevent hypoxia during intubation, provide free flow oxygen, limit intubation attempt to 20 seconds and avoid excessive flexion of neck.

Precautions during extubation (1) Give free-flow oxygen through the lid of the endotracheal tube for a few seconds, (2) Always take help of a laryngoscope during extubation, (3) Continue bag and mask ventilation for 15 seconds after extubation.

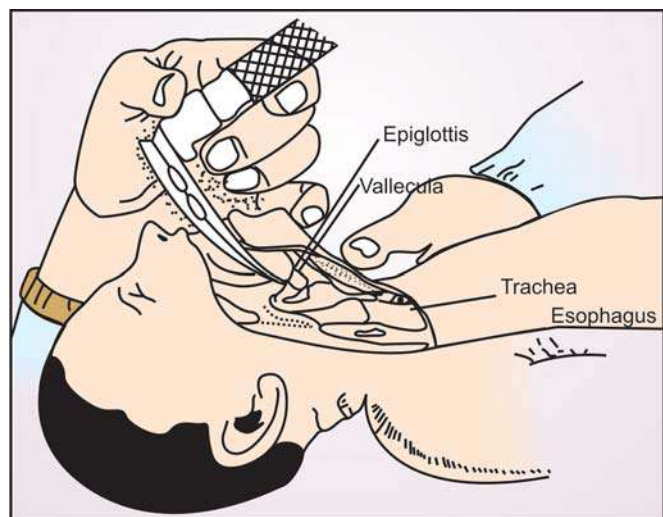

Fig. 17.18: Endotracheal intubation technique: Note the endotracheal tube in position. It is inserted upto 2.5 cm beyond the vocal cord

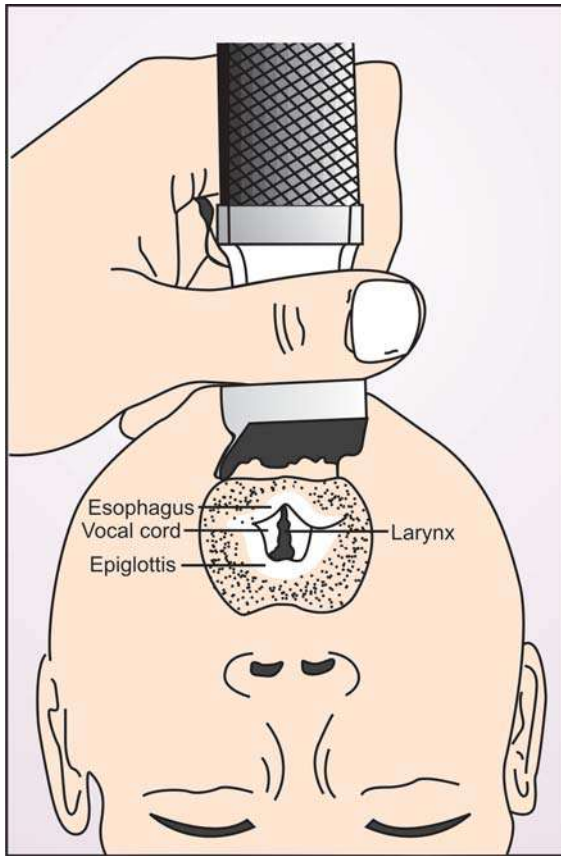

Fig. 17.19: Endotracheal intubation technique. The glottis (triangular opening formed by vocal cord and arytenoid cartilage) as viewed through laryngoscope

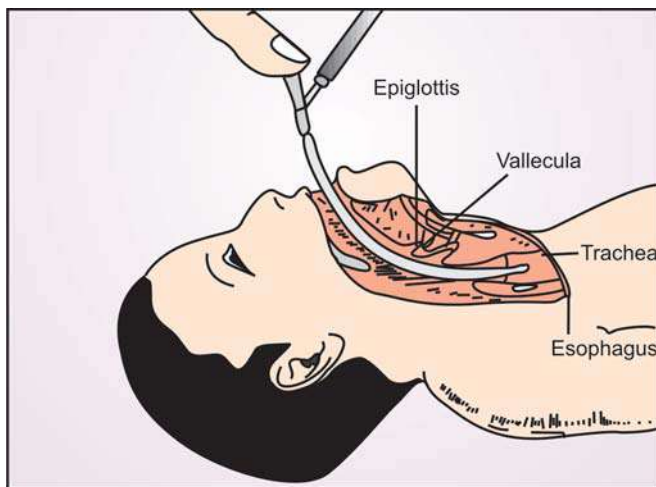

Fig. 17.20: Endotracheal intubation technique. Note the tube in position 2.5 cm beyond the vocal cord

Box 17.4: Bag and mask ventilation

Indication: (1) Apnea/gasping (2) Heart rate < 100/minute

Equipment; (1) Resuscitation bag (self-inflating, capacity 240-260 ml) (Fig. 17.21) (2) Oxygen (90-100%) (3) Masks (well-fitting, cushioned) (4) Oxygen equipment (source, flowmeter, tubing, etc)

Procedure: The baby's neck should be slightly extended to ensure an open airway while he lies on his back. An appropriate-sized bag and mask is selected. The mask is placed in position so that it covers the mouth and the nose but not the eyes. Then, bagging is started at a rate of 40-60 / minute for 15-30 seconds, using enough pressure to cause chest movements.

Evaluation: If heart rate > 100/minute and infant having spontaneous breathing, stop bagging (ventilation). If heart rate > 100 but infant yet not having spontaneous breathing or is gasping, continue ventilation. If heart rate 60-100/minute and not increasing, continue ventilation and check for adequacy of ventilation from chest elevation. If heart rate 60-100/minute and increasing, continue ventilation. If heart rate < 80/minute, start chest compressions. If heart rate < 60/minute, continue to ventilate, start chest compressions and consider intubation.

Signs of Improvement: (1) Rising heart rate, (2) Spontaneous breathing, (3) Improving color.

Risks: Abdominal distention because of gastric distention from entry of air into stomach during ventilation exceeding 2 minutes.

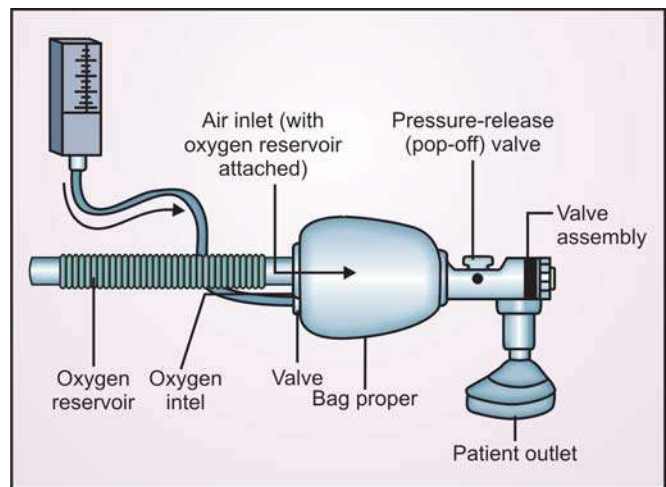

Fig. 17.21: Self-inflating bag. A 250-750 ml size bag comprising 4 major components (inlet, bag proper, patient outlet and O₂ reservoir) is appropriate for a neonatal. The most often employed gadget is AMBII (artificial manual breathing unit)

Box 17.5: Chest compression

Indications: If after 15-30 seconds of PPV with 100% oxygen, heart rate remains < 60/minute or it is 60-80/minute but not increasing.

Site: Lower third of the sternum below the imaginary line drawn between two nipples.

Procedure: In the thumb technique thumbs are employed to compress the sternum while the fingers support the back and the hand encircles the torso. In the two-finger technique, the finger tips (middle finger with index finger or ring finger) one hand are employed to compress the sternum. The other hand supports the neonate's back. The rate of chest compressions should be 120/minute and depth 1-2 cm. During the procedure, fingers of thumbs must never be taken off the sternum in between compressions.

Evaluation: Thirty seconds of chest compression should be followed by rechecking of the heart rate. If it is below 80/minute, the procedure should continue along with bag and mask ventilation with 100% oxygen, plus medication (vide text). If heart rate is >80/minute, stop chest compression but continue ventilation until heart rate crosses 100/minute and the baby is breathing spontaneously.

Risks: Trauma to the chest in the form of fractures, pneumothorax and laceration of liver.

expanders, sodium bicarbonate, naloxone and dopamine. There is no place for dexamethasone, atropine, mannitol, calcium, dextrose in resuscitation in the delivery room.

1. *Epinephrine* A 1 in 10,000, 0.1- 0.3 ml/kg (IV, IT) is given rapidly. The same dose may be repeated every 5 minutes
2. *Volume expanders* Normal saline, whole blood, 5% albumin or Ringer lactate is indicated in the event of an acute bleeding with signs of hypovolemia.
3. *Sodium bicarbonate:* 1 to 2 mEq/kg/minute of 4.2% solution slowly over 2-minute period after effective ventilation has been established. It is indicated only in the event of documented metabolic acidosis. Else, there is risk of such a therapy producing respiratory acidosis.
4. *Dopamine* 5 to 20 mcg/kg/minute as a continuous IV infusion in poor peripheral perfusion, weak pulses, hypotension, tachycardia and urine output persisting after the initial resuscitative efforts.

5. *Naloxone* 0.01 mg/kg (IV, SC, IM, intratracheal) is indicated in case of history of maternal narcotic drug administration. Along with this, adequate ventilation is maintained.

Resuscitation Steps

The neonatal flow algorithm in (Fig. 17.22) gives steps of action for neonatal resuscitation.

Don'ts in Neonatal Resuscitation

These are listed in Table 17.3.

As the baby starts breathing on his own, the endotracheal tube should be removed. Brushing the soles of the feet stimulates crying and is recommended. *It is a sound principle never to leave a baby needing resuscitation until and unless he is crying well.*

APGAR SCORE

First put forward by Professor Virginia Apgar, a renowned New York-based anesthesiologist, in 1953, Apgar score is a quantitative assessment of neonate's condition at birth, especially with reference to the respiratory, circulatory and neurologic status (Table 17.4). It is of no use for taking a decision regarding the steps of resuscitation since the latter would be needed within a minute i.e. before the scoring is actually done.

Table 17.3: Certain vital "don'ts" in neonatal resuscitation

- Don't administer heavy sedation to the mother
- Don't do heavy and continuous suction.
- Don't let the neonate develop hypothermia.
- Don't carry on with tactile stimulation beyond 2 and never beyond 4 flicks.
- Don't delay endotracheal intubation in an apneic neonate.
- Don't blow your lungs into neonate's mouth.
- Don't use full palmar grasp for giving bag and mask ventilation.
- Don't give respiratory stimulants.
- Don't suck the nose first and the mouth later. The breathing effort that follows sucking the nose first may allow secretions in the mouth to be suddenly aspirated into the lower airway
- Don't slap the back
- Don't squeeze the rib cage
- Don't force thighs on the abdomen
- Don't dilate the anal sphincters.

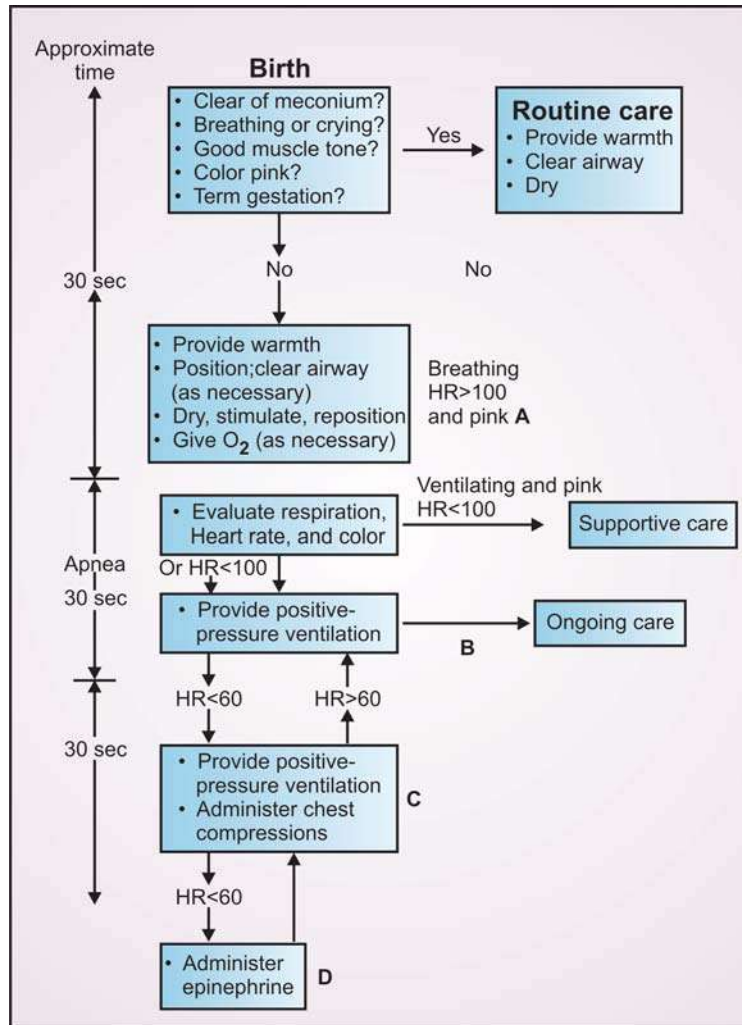

Fig. 17.22: Algorithm regarding the brief outline of steps of action for neonatal resuscitation

Table 17.4: Apgar scoring system

Clinical features	Score 0	Score 1	Score 2
Appearance (Color)	Blue or pale	Body pink, limbs blue	Pink all over
Pulse (Heart rate)	Nil	Less than 100 per minute	Over 100 per minute
Grimace (Response to catheter put into nostril or stimulation of sole of foot)	Nil	Grimace or feeble cry	Cry or sneezing
Activity and tone	Limp	Some flexion of limbs	Active movements
Respiration	Nil	Slow, irregular	Good, strong cry

Apgar scoring system is employed to plan management of the newborn after resuscitation has been accomplished. Contrary to the commonly-held belief, it has absolutely no role in deciding steps of resuscitation in the labor room.

Interpretation of one minute score It is categorized in Table 17.5.

THE FULLTERM NEWBORN (Box 17.6)

Physical Characteristics

The normal full-term newborn weighs around 3.4 kg (range 2.5 to 4.6 kg), and the length averages around 50 cm (range 45 to 55 cm).

The head circumference is about 35 cm (range 32.6 to 37.2 cm).

Table 17.5: Interpretation of one minute Apgar score

Apgar score	Interpretation	Action needed
7-10	Excellent condition with no birth asphyxia	Needs no particular observation
4-6	Moderate birth asphyxia	May be shifted to mother but needs to be carefully observed
0-3	Severe birth asphyxia	Needs care in NICU

Interpretation of the Later Score The 5 minute score predicts possible prognosis. The extended score at 20 minutes is far more specific for predicting morbidity and mortality.

Criticism/Limitations of the Apgar Score (1) Apgar score is of no particular utility in deciding steps of resuscitation in the labor room. In fact, at the end of 1 min, precious time has already been lost for effective resuscitation. (2) Gestation age has significant bearing on muscle tone and reflex response (3) Acrocyanosis, a normal finding in the newborn, is assigned Score 1. (4) The score may give erroneous information. For instance, low score may well be secondary to causes other than birth asphyxia, namely immature CNS, naso-pharyngeal suction, maternal medication, maternal anesthesia or neonatal sepsis. (5) It provides no clue even for future neurologic outcome,

The chest circumference is approximately 3 cm less than the head circumference at birth. The chest is rounded rather than flattened anteroposteriorly. The abdomen is prominent.

The upper segment/lower segment ratio is 1.7: 1. In other words the trunk is relatively larger and the extremities short. The midpoint of the length (stature), therefore, lies at the umbilicus instead of the symphysis pubis as in grown-up children and adults.

The newborn's posture is a prototype of the partial flexion attitude *in utero*.

The external auditory canal is relatively short and straight and the eardrum thick. The eustachian tube is short and broad. The mucoid material in the middle ear may simulate an exudate of infection.

The maxillary and ethmoid sinuses are small. The frontal and sphenoidal sinuses are poorly developed.

The kidneys are often palpable; so are the liver and spleen just below the costal margins.

The traumatic effects of labor may be encountered in the form of edema of the vertex and overriding of the cranial bones.

The pinkish or mottled skin on the dorsal aspects of extremities and upper back is covered with lanugo hair.

The sclerae tend to be somewhat bluish. The ear cartilage is fully curved and firm, showing quite good elastic recoil.

Box 17.6: Noteworthy peculiarities of the full-term neonate in nutshell

Anthropometry

Weight 3 kg (2.5 – 4.6 kg)

Length 50 cm (45 – 55 cm)

Head circumference 35 cm

Chest circumference 32 cm

Upper segment/lower segment ratio 1.7:1

(crown-rump/rump-heel ratio)

Midpoint of length lies at umbilicus rather than at pubic symphysis

Vitals

Respiratory rate 40/min (35-50/min)

Heart rate 140/min (120-160/min)

Hematologic Status

Hemoglobin 18 g/dL

Miscellaneous

Posture is of partial flexion

Palpability of liver and spleen is usual

Palpability of kidneys may be present in some

Sinuses are small and underdeveloped

Only solitary mastoid cell in antrum

Eustachian tube is short and broad

Ear drum placed more obliquely

External auditory canal short and straight.

The breast nodule is palpable, measuring over 5 mm in diameter.

The scrotum shows adequate rugae and deep pigmentation. At least one testis is fully palpable in the scrotum. The labia majora covers the labia minora.

The sole of foot shows prominent deep creases in anterior 2/3rd or more area.

Physiologic Characteristics

The established respiratory rate varies between 35 and 50/minute. Crying tends to enhance the rate up to 60/minute. Peripheral cyanosis may be encountered for a short while after birth.

The heart rate varies between 120 and 160/minute. Besides high cardiothoracic ratio as compared to an adult, transient benign murmurs are often heard.

The cry is, as a rule, vigorous. Rooting (turning the head towards and to root about a stimulus placed close to the mouth), suckling, gagging and swallowing reflexes are well developed. The newborn is, therefore, capable of accepting breastfeeding within a few hours

following delivery when the recovery from exhaustion of birth is over.

The initial demand for feed at irregular intervals gives way, by the end of the first week, to a fairly regularized pattern of demand at 2 to 5 hours.

The first stools (meconium) are passed within 24 hours and are black-colored, thick and viscid. On third to fourth day, these are replaced by greenish-brown stools with milk curds, the so-called "transitional stools". After another gap of 3 to 4 days, typical milk stools follow.

The first urine is passed during or shortly after birth. A proportion of the newborns may take 24 hours or even longer to pass urine. Failure to pass urine by 48 hours is a matter of concern. The output and GFR show rapid increase in the first two weeks. Abundance of urates gives the diaper a pink stain.

The body temperature quickly falls after birth but is reverted within 4 to 8 hours.

The energy requirements initially are 55 kcal/kg/day but rise to 110 kcal/kg/day by the end of the first week.

On an average, the term newborn loses about 6% of body weight during the first week. The weight loss may be up to 10% (up to 15% in preterms). If the loss is in excess of 10%, dehydration fever on the third to fourth day may develop. The initial weight loss is made up by the tenth day.

The hemoglobin is high (around 18 g/dl) with slight reticulocytosis, normoblastemia and leukocytosis (up to 35,000/cmm) on first couple of days after birth. Notably, stressful situations (say fulminant infections) may cause only negligible leukocytosis and even leukopenia.

Establishment of normal homeostatic mechanism depends on acquisition of normal intestinal flora and elaboration of vitamin K rather than on minimal passage of clotting factors from the mother.

Blood sugar is relatively low in the newborn and a fall below 20 mg/dl may cause seizures. Likewise, blood calcium is low and a falls below 7.5 mg/dl may lead to seizures.

Though IgG level of the newborn is quite high, his IgM, IgA and IgE levels are negligible. IgM near absence in the newborn predisposes him to gram-negative bacillary infections. T lymphocyte functions too are reduced in the neonate.

Fat is not as efficiently digested by the newborn as protein and carbohydrates.

At cellular level, red cells are more vulnerable to hemolysis. There is greater risk of unconjugated hyperbilirubinemia, and enhanced risk from drug therapy because of reduced capacity to metabolize certain drugs.

Neurodevelopment

The following 6 levels of behavioral state or the level of arousal (wakefulness) are recognized:

Level 1: Deep sleep

Level 2: Sleep with rapid eye movements (REM)

Level 3: Drowsy state (quiet wakefulness)

Level 4: Quiet active, alert state; good interaction with environments

Level 5: Awake and active state

Level 6: State of active intense crying.

Within the first hour or two after birth, the newborn spends a substantial time in level 4. In the subsequent few days, the infant spends just around 10% of the day in this state.

During the first week, the infant is capable of maintaining visual fixations on faces (human faces in particular), light, or movements against passive movements of his body, the so-called *doll's eye reflex*.

The *orienting response* refers to the spectrum of behavior of a newborn to environmental stimuli in the form of "startle", altered heart rate, alertness, and suppression of spontaneous movements. As a result of repetition of the stimulus, *habituation* of the response occurs and there is less startle and cardiac acceleration.

The *neonatal behavioral assessment scale (NBAS)* is designed to provide a far better assessment of the neonate's behavior than the conventional neurologic examination. In predicting future development and function, NBAS perhaps provides a more accurate prognosis during the first couple of weeks than the Apgar score at 1 and 5 minute. The scale determines the behavior in the following 4 dimensions:

- Interactive processes: orientation, alertness, consolability, cuddliness.
- Motor processes: muscular tone, motor maturity, defensive reactions, hand-to-mouth activity, general activity level, reflex behavior.
- Control of physiologic state: habituation to a bright light, rattle, and pinprick; self-quieting behavior.
- Response to stress: tremulousness, lability of skin color, startle reaction.

Psychosocial Development

Experiences during pregnancy, labor, and first hours after delivery have the effect of *bonding* the parents to some degree to the infant. This realization has led to revision in traditional practices, leading to involvement of parents in prenatal programs, encouragement of family-centered activities for pregnancy and childbirth, boosting of breast-feeding, and rooming-in arrangements in the neonatal period.

PRIMITIVE NEONATAL REFLEXES

Among the large number of primitive neonatal reflexes, the following should be elicited for their normalcy, sluggishness or exaggeration, and symmetry (Figs 17.23 to 17.31).



Fig. 17.23: Grasp reflex (Grade I)

Moro Reflex

It consists of rapid abduction (at shoulder) and extension (at elbows) as also complete opening of the hands followed by adduction and flexion of the arms or embrace equivalent.

This is elicited by any of the following maneuvers:

1. The baby is put supine on the cot or table. Then his hands are grasped and he is pulled so that the shoulders are lifted a few cm but the head remains in touch with the surface, causing an angulation between the head and the trunk. At this point, the hands are suddenly released to cause sudden extension of the neck.
2. The neonate is held supine over the hand and arm. Then, the flexed head is suddenly allowed to drop by around 30°.



Fig. 17.25: Rooting reflex



Fig. 17.24: Grasp reflex (Grade III)

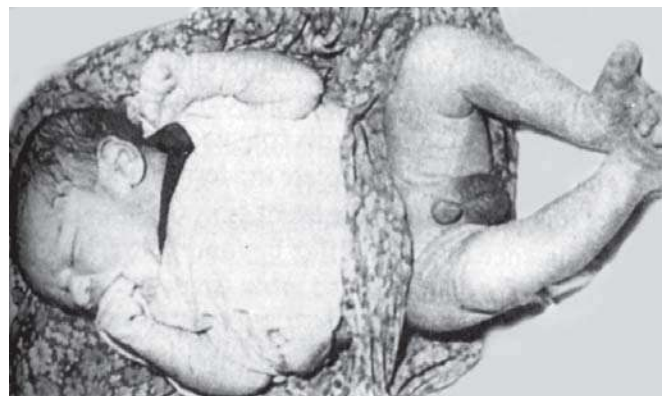

Fig. 17.26: Suckling reflex

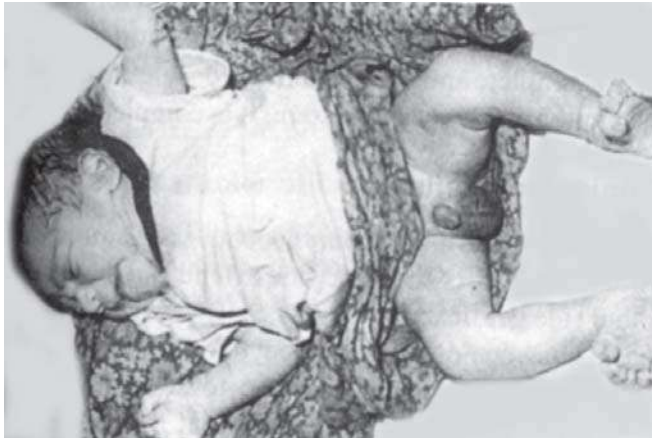

Fig. 17.27: *Moro reflex (phase I):* Sudden drop of the flexed head by 30 degrees, results in rapid abduction and extension of upper limbs

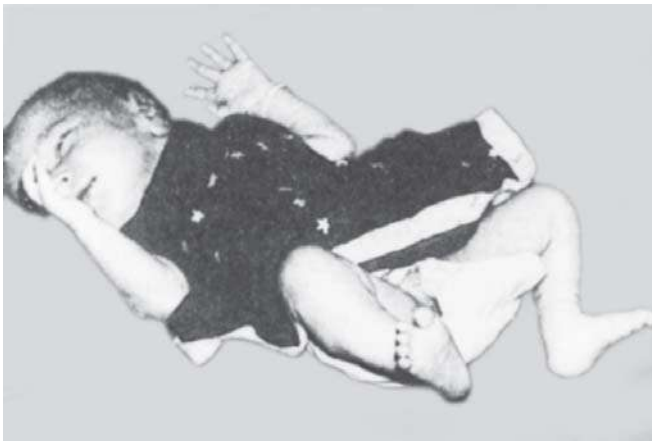

Fig 17.28: *Moro reflex (phase II):* The response in phase I is followed by adduction and reflexion of the arms



Fig. 17.29: *Glabellar reflex:* On tapping the nasion; the eyes close



Fig. 17.30: *Stepping reflex:* Note that the neonate shows movements of walking when held upright and inclined forward with soles touching a flat surface. Placing reflex consists of flexion followed by extension when the dorsum is drawn along the under edge of a table



Fig. 17.31: Extensor plantar (Babinski) response

Moro reflex is complete after 32 weeks of gestation though it may be elicitable in only 20-25% of the neonates. It can be elicited even after 28 weeks of gestation but the abduction component is rather weak.

A depressed or absent Moro reflex suggests cerebral depression. In cerebral irritability, on the other hand, it is exaggerated. Asymmetrical reflex points to fracture of clavicle or humerus, brachial palsy (Erbs palsy) or spastic hemiplegic CP. In kernicterus, the second component shows no flexion of arms; instead it is replaced by downward rolling of eyeballs as in "sunset" sign, lid lag and a characteristic grin.

Persistence of Moro reflex beyond 12 weeks of age is pathognomonic of CNS pathology.

Startle Response

A sudden, sharp blow is given over the cot or table close to the neonate's head. A positive response consists of sudden abduction (at shoulders) and extension (at elbows) of the arms as also complete opening of hands followed by adduction and flexion (slow) or embrace equivalent.

Rooting and Suckling Reflexes

Stimulation of the lip or angle of the mouth, say with a finger tip or the breast nipple as such, causes the infant seek the stimulus (rooting reflex) and movements of the lips and tongue in the direction of the stimulus (suckling reflex). Suckling reflex can be further evaluated by introducing a finger into the infant's mouth and noting the strength as well as the rhythm of suckling. It is strong and well synchronized with swallowing at 32 weeks. At 28 weeks, it is weak and not synchronized with swallowing. In sick infants too, it is weak.

Glabellar Reflex/Tap

It comprises tapping of the glabella or nasion (the meeting point of forehead and nose). The neonate reacts by closure of eyes or blinking.

Grasp Reflex

It consists in placing the examiner's index finger on the neonate's palm. The infant immediately grasps it. The grasp is so firm that he can be lifted off the cot by means of this only. On stroking the dorsum of the hand, he opens the fist, thereby releasing the examiner's finger.

A prototype of palmar grasp can be elicited by stroking the plantar surface of toes of the neonate. The infant responds by flexing the digits (plantar grasp).

The grasp reflex is complete in a term neonate. By 34 weeks it is only partially present.

Persistence of grasp reflex beyond 12 weeks of age points to brain damage.

Crossed Extension Reflex

Stroking the foot as the leg is held extended at knee causes flexion, abduction and extension, and

adduction together with fanning of the toes of the other leg. The response stimulates warding off painful stimuli.

Incomplete and in a random purposeless manner, it is elicited at 32 weeks. At term, it is complete.

Tonic Neck Reflex

On suddenly turning a supine neonate's head to one side, the arm and leg of the same side extend and those of the other side get flexed.

Persistence of the reflex beyond the age of 6 to 9 months, or maintenance of the tonic neck posture constantly even at an early age point to existence of cerebral palsy.

Traction Reflex

This reflex is elicited by holding the supine neonate at the wrists and then pulling him up. The infant responds by flexing the arms and neck.

Plantar (Babinski) Reflex

It is elicited by stimulating the lateral aspect of the sole of the foot, beginning at the heel and extending to the base of the toes, with a firm object such as examiner's thumb or a handy key. The positive response is characterized by extension of the great toe and fanning of the other toes. Before showing characteristic extensor response, most neonates show an initial flexion of the great toe.

Asymmetry of the Babinski reflex between extremities is a vital lateralizing sign.

Chvostek Sign

This well-known sign of latent tetany may be present in normal neonates. It is elicited by tapping the area anterior to the external auditory meatus, thereby stimulating the facial nerve. The neonate responds by a twitch of the upper lip or the full mouth as a result of contraction of the orbicularis oris.

Two primitive reflexes (not neonatal) appearing at 8-9 months of intrauterine life are:

Parachute Reflex

This reflex consists in suddenly lowering the neonate from a short distance in ventral suspension. The maneuver is followed by extension of arms, hands and fingers.

Landau Reflex

When the neonate is suspended in prone position with the examiner's hand under the abdomen, he responds by extension of head, trunk and hips. On flexing the head, trunk and hips also show flexion.

2 SOME MINOR PROBLEMS OF THE NEWBORN THAT MAY CAUSE PARENTAL ANXIETY

Physiologic Jaundice

This benign condition has already been dealt with under "Neonatal jaundice" in this very chapter.

Vomiting

Swallowed amniotic fluid may be responsible for some vomiting on the first day in most normal neonates. It needs no intervention. In case it persists, stomach wash should be done with normal saline and the infant given only 5% glucose in water in place of the subsequent two feeds.

Aerophagy or erratic feeding may be responsible for regurgitation/vomiting. Proper burping usually solves the problem.

Transitional Stools

Within 12 to 24 hours, the infant passes dark meconium. In 2 to 3 days, stools change color to yellow-green and are loose and frequent. These are called "transitional stools" and are perfectly normal in infants fed on mother's milk.

Constipation

Whereas breastfed infants may pass several motions, in bottlefed babies the usual complaint is constipation as a result of hard casein curds. Mothers must never be encouraged to give laxatives to such a baby. Instead, simple measure such as administration of a juice, glucose water or extrasugar in milk gives gratifying results.

Toxic Erythema (*Erythema Toxicum*)

In term infants, an erythematous rash (like a flea bite) may appear on the second day and disappear on its own by fourth day without any treatment. There are no systemic manifestations. The cause is unknown. No bacteria have been cultured from the lesions.

Milia

These are multiple yellow-white, 1 mm size, cysts which may be few or numerous. The sites are nose, nasolabial folds, cheeks and forehead. No treatment is needed since they disappear spontaneously in the first few weeks.

Mongolian Spots

These are blue-black macules usually found over the lumbosacral area, buttocks (Fig. 17.32) and, occasionally, back and shoulders in 70% of the oriental newborns. The macule may be as big as 10 cm in diameter and even larger. The cause is infiltration of melanocytes in deep layer of dermis. Disappearance occurs gradually as the infant grows, usually during first few years. Traces may persist into adult life. The condition is harmless.



Fig. 17.32: Mongolian spots. Note the large blue-black macules. These spots tend to disappear as the infant grows, usually in the first few years. These are harmless

Salmon Patches (*Macular Hemangioma, Nevus Simplex, Stork Bites*)

Pinkish capillary hemangiomas may be present over nape, eyelids (upper) and glabella in 30 to 50% of normal newborns. Disappearance occurs in the first year though nuchal lesions may persist in one-fourth of the adult population.

Benign Neonatal Hemangiomatosis (BNH)

Multiple capillary hemangiomas, varying from pinhead to 20 mm in diameter, may be present only over the skin right at birth or appear somewhat later. They show rapid increase in size till 2 weeks of age. Then, they begin to regress spontaneously. By fourth month, complete involution occurs.

BNH needs to be differentiated from diffuse neonatal hemangiomatosis which also involves the viscera and may bleed profusely.

Harlequin Color Change

When the newborn is placed on his side, a sharp midline divides the body into a pale upper half and a very red lower half. The cause appears to be temporary imbalance in the autonomic regulatory mechanism of the cutaneous vessels. Such an episode has no pathologic significance.

Epstein Pearls

Lateral to the midline of the hard palate may be seen whitish spots (one on each side) which are supposedly epithelial inclusion. These are of no significance.

Sucking Callosities

These signify attempts of the baby at sucking during intrauterine life. These are seen as buttonlike cornified plaque over center of the upper lip.

Subconjunctival Hemorrhage

It may manifest as a semilunar area at the outer canthus. Total disappearance occurs within a few days time.

Physiologic Mastitis

Bilateral swelling of the breasts, which is hormonally induced, may occur about the fourth day and disappear spontaneously by 2 to 3 weeks. No

treatment is indicated. The common practice of massaging and expressing milk (the so-called "witch's milk") is unfounded and may do harm rather than any good. The condition should, however, be differentiated from the mastitis or breast abscess which may result from infection with *staphylococcus* or *E. coli*. Breast abscess is usually unilateral.

Vaginal Bleeding

Withdrawal of maternal hormonal supply may cause slight vaginal bleeding on third day. It disappears by seventh day and is harmless.

Natal Teeth

Rarely the newborn may be born with one or two already erupted teeth (Fig. 17.33). These need not be extracted unless they interfere with breastfeeding or they are loose. Julius Caesar had natal teeth.

Cephalhematoma

Already dealt with under "Birth injuries" in this very chapter.

Caput Succedaneum

Already dealt with under "Birth injuries" in this very chapter.



Figs 17.33: Natal teeth. The condition is rare and harmless. Extraction is indicated if teeth are loose or if they interfere with feeding

Hiccup (*Hiccough*)

The term refers to sudden, involuntary, jerky diaphragmatic contractions, causing abrupt inspiratory episodes against a closed or closing glottis. It occurs intermittently after feeds in normal infants and is of no significance. If the attacks are prolonged, discomfort, fatigue and malnutrition may develop. The remedial measures include tickling the nostril, orbital pressure, carotid sinus pressure, induction of vomiting and therapy with such drugs as chlorpromazine or metoclopramide.

Nasolacrimal Duct Blockade

A proportion (2%) of the newborn may have persistent watery discharge and even conjunctivitis (usually unilateral). It is usually due to simple congenital obstruction of the nasolacrimal duct and clears spontaneously by 1 to 3 months. All that is needed is frequent "wash" of the eye with a moist sterile swab, and gentle massage of the skin over the tear passage. In the presence of an infection, antimicrobial eye drops may be indicated. In case of blockade persisting in later months, surgical correction is necessary after the child has attained the age of 2 years.

Umbilical Hernia (Fig. 17.34)

It is a commonly encountered condition in newborns. The cause is weakness or faulty closure of the umbilical ring. It may be found in otherwise normal infants but may well be a manifestation of cretinism or gargoylism in the presence of some other manifestations of the disease. Two types are recognized. First: *false* in which hernia occurs into the cord itself. It is persistence of the physiologic condition. In the second, i.e., *true*,

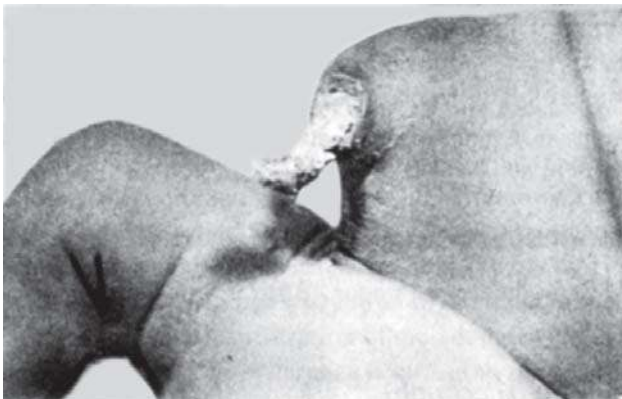

Fig. 17.34: Umbilical hernia

protrusion is through the umbilical cicatrix. It occurs in 25 to 50% of oriental infants which is 6 to 10 times higher than the incidence in the whites.

Normally, it has a tendency to reduce in size after 6 months (when the infant begins to sit and abdominal muscles develop), and subside by the age of 18 months spontaneously. The old practice of strapping it (with or without a large coin) may actually interfere with its spontaneous regression. Unlike paraumbilical or inguinal hernia, it seldom causes strangulation or incarceration.

Hydrocele

Noncommunicating hydrocele, more often on the right side, presenting with a well transilluminated scrotal swelling is quite common in neonates. It usually disappears spontaneously by 6 months of age. In case of its persistence beyond one year of age, herniotomy is needed.

Physiologic Phimosis

Many male newborns may have a prepuce that is adherent to the underlying glans. This is physiologic finding and disappears in due course. The condition should be considered pathologic only if the difficulty in retracting the prepuce over the glans is persistent beyond 3 years of age and causes bulging of the foreskin on passing urine.

Mothers need to be advised not to attempt to forcibly retract the so-called "nonretractable" foreskin.

Hymenal Tags

About 60% of normal baby girls show mucosal tags at the margin of the hymen. These are of no particular significance.

THE PRETERM INFANT

By definition, the term refers to a baby born before a gestation period of 37 weeks. This replaces the old term *prematurity*.

Preterm neonates contribute to a large chunk of low birthweight (LBW) i.e. weighing < 2500 g. Such a baby measures 46 cm or less in length (crown-heel) and has head circumference of 32 cm or less. The chest circumference is usually less than 30 cm.

Predisposing Causes

- Poor nutritional status of the mother
- Maternal illness like toxemias, antepartum hemorrhage (APH), anemia and chronic infections
- Excessive smoking, drugs
- Overwork, fatigue, mental tension etc
- Twinning
- Increasing parity
- High altitude.

Characteristic Features

The special features of the preterm infant are shown in Figure 17.35 and Table 17.6.

Handicaps/Risks

The immaturity, both functional and anatomic, predisposes a preterm to, among others, the following handicaps.

- Respiratory distress syndrome. The hyaline membrane disease occurs exclusively in babies born before term. It is never seen in term infants.
- Neonatal jaundice. Physiologic jaundice is relatively, severer, prolonged and more frequent in these babies
- Greater susceptibility to infections, e.g. septicemia
- Higher frequency of apneic spells, aspiration, bradycardia, neurologic immaturity
- Anemia of prematurity
- Hypothermia
- Hypoglycemia
- Feeding difficulties
- Functional ileus

Table 17.6: Special feature of preterm neonates

- Relative head is large
- Craniotabes present
- Fine fuzzy, scanty hair
- Large fontanelle and sutures
- Poor ear cartilage
- Absent eyebrows but prominent eyes
- Buccal pad of fat is minimal
- Excessive lanugo hair present all over the body
- Small chest
- Breast nodules very small or absent with small nipple
- Relatively large abdomen
- Liver, spleen and kidneys are often palpable
- Umbilical hernia may be present
- Visible gut peristalsis may be there
- Undescended tests, light-coloured scrotal skin with few rugosities are seen
- In girl child labia majora does not cover labia minora (Fig. 17.36)
- On soles—very few creases are seen
- Nails are soft
- Overall poor musculature and less subcutaneous fat

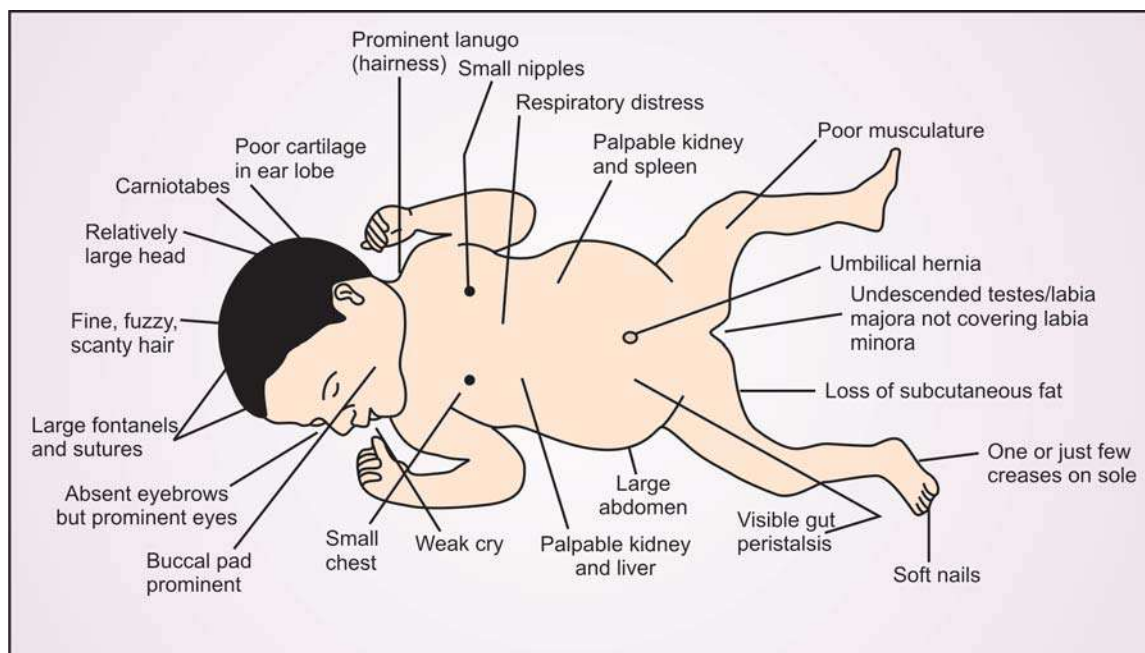

Fig. 17.35: Special features of a preterm baby



Fig. 17.36: Prematurity, showing papilla angle of 180 degree. Also note that labia minora and clitoris are edematous so that labia majora are widely placed and not covering labia minora

- Intraventricular hemorrhage
- Necrotizing enterocolitis
- Retrolental fibroplasia (retinopathy of prematurity) (Fig. 17.37).
- Hemorrhagic disease of the newborn

Though until recently believed to be entirely the result of supplemental oxygen, ROP is now hypothesized to have “light” as a significant contributory factor in its development. Bright light is supposed to act by producing chemically excited state and generating free radicals.

In short, a preterm baby has several disadvantages that predispose him to risks. The more the immaturity, the poorer are the chances of survival of such a baby.

LOW BIRTH WEIGHT (LBW) INFANTS

According to the WHO, babies with a birth weight of 2,500 g or less should be designated as low birth weight (LBW) babies. The term, *very low birth weight*, refers to a birth weight between 1,000 g and 1,500 g, and *extremely low birth weight* to a birth weight less than 1,000 g. The term, *micropremie*, is being applied for babies below 5,00 g birth weight.

LBW may either be due to prematurity or intrauterine growth retardation (IUGR).

The magnitude of low birth weight infants in developing world is enormous. Out of a total of

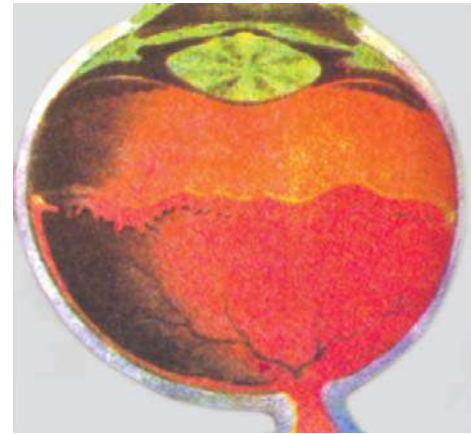

Fig. 17.37: Retinopathy of prematurity (ROP). An artist's depiction of the condition developing in a premature infant's eye as a result of blood vessels growing into the vitreous humour anteriorly

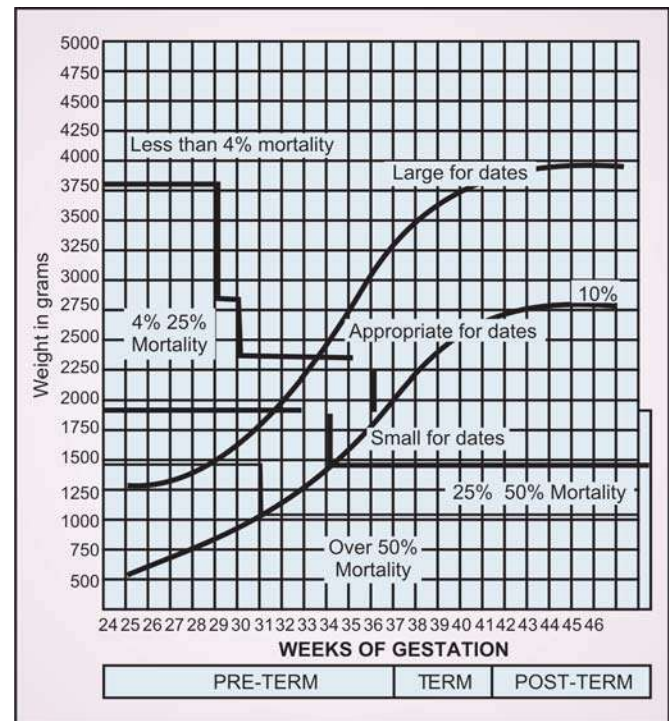

Fig. 17.38: Practical classification of newborns by weight and gestational age

22 million such infants in the world, 21 million belong to the developing countries. India's share is quite substantial: 7 to 10 million. LBW constitutes 30% of live births in India.

Figure 17.38 provides practical classification of newborns by weight and gestational age.

Classification

1. *Malnourished* The baby appears marasmic, long and thin, skin losing its normal elasticity and hanging in folds over the buttocks. Internal organs with the exception of brain are shrunk. Head circumference remains nearly normal and is over 3 cm more than the chest circumference. Ponderal index* is below 2 against the normal of over 2.5. Since cell number is not affected, these infants are responsive to nutritional rehabilitation.
2. *Hypoplastic* Such a baby is proportionately small in all parameters. Since cell population is reduced, growth potential is considerably affected, resulting in permanent retardation of physical and mental growth. Incidence of accompanying congenital malformations is high.
3. *Mixed* Such a baby neither appears as malnourished as in type I nor as hypoplastic as in type II. Reduction in cell size as well as number is characteristic of this type of IUGR.

Etiology

1. *Maternal malnutrition* Food deprivation, particularly during the last weeks of pregnancy, more so when the mother is already undernourished (weight under 40 kg, height under 145 cm) leads to birth of malnourished infant. There is evidence that adequate food supplementation in pregnancy considerably reduces the incidence of IUGR.
2. *Intrauterine infections* Such intrauterine infections as toxoplasmosis, cytomegalovirus disease, rubella, herpes, syphilis, etc. may exert their adverse influence early in embryonic life, causing hypoplastic type of IUGR.
3. *Placental dysfunction* Such maternal problems as toxemias of pregnancy and hypertension may be responsible for placental dysfunction and IUGR.
4. *Maternal diseases* Chronic maternal diseases such as heart disease, tuberculosis, renal disease, bronchial asthma, etc. are likely to cause IUGR.
5. *Genetic/chromosomal disorders* Certain genetic disorders (short-limbed dwarfism) and chromosomal disorders (Turner syndrome, trisomies) exert their adverse influence early during gestation, reducing both cell number and cell size.

* Ponderal index = $\frac{\text{Weight (g)}}{\text{Length (cm)}^3} \times 100$

The result is hypoplastic IUGR with reduced growth potentials.

6. *Twin pregnancy* After 35 weeks of gestation, the mother is not capable of providing adequate nourishment to more than one fetus.
7. *Miscellaneous* Teenage pregnancy, narcotic addiction, teratogenic agents, tobacco smoking, high altitude, irradiation, pregnancy-out-of-wedlock.

Handicaps/Risks

1. Aspiration of meconium, amniotic fluid or vernix caseosa
2. Asphyxia as a result of cerebral anoxia
3. Fetal hypoxia/death from placental dysfunction
4. Symptomatic hypoglycemia
5. Polycythemia from chronic hypoxia
6. Pulmonary hemorrhage
7. Congenital malformations
8. Poor temperature regulation
9. Hyperbilirubinemia
10. Permanent retardation in linear growth and psychomotor development.

Management

The pediatrician should be prepared to prevent/ tackle the risks/handicaps mentioned above. For instance, he should have arrangements for resuscitating an asphyxiated infant, a baby with aspiration, or a baby with congenital malformations. Early feeding not only prevents hypoglycemia but also leads to rapid weight gain after 3 to 4 days of age.

Prognosis

IUGR infants are easy to feed and show rapid weight gain after age of 3 to 4 days which slows down after age of 6 months.

Though prognosis is much better than in preterm infants, mortality is 2 to 3 times higher than in normal babies.

Whereas permanent retardation in physical growth is a feature of hypoplastic babies, the malnourished infants, particularly those with hypoglycemia, show higher incidence of brain damage (learning disability, MBD) and suboptimal physical growth later in life.

Prevention

1. *Female literacy and formal education* A well-informed, educated mother is likely to have better health

before and during pregnancy, avoid harmful agents and influences during pregnancy and show better reproductive performance and outcome. Education and training of the traditional birth attendants (TBAs) to ensure adequate care of the mothers during pregnancy and their referral to a nearby health center in case of high-risk pregnancy is also important.

2. **Maternal health status** Adequate nutrition of the female throughout childhood and adolescence is a very effective way of ensuring good health status of pregnant women, provided that the so-called "previous nutritional status" is maintained by continued good nourishment and freedom from medical ailments.
3. **Antenatal care** There is evidence that birth weight is directly proportional to the number of antenatal check-ups. Early detection of high-risk factors such as intrauterine infections, hypertension, toxemias of pregnancy and early intervention can prevent occurrence of IUGR.
4. **Maternal infections** such as malaria UTI, TORCH/STORCH, etc., if prevented or if tackled in time, can considerably reduce the incidence of IUGR.

Feeding

Feeding of the LBW infants is discussed in Chapter 12 (Infant Feeding).

STAGES OF NEWBORN CARE

Care of the newborn should start much earlier than the time of birth. Newborn period is not a beginning but a continuation of what has gone before.

Following important five stages are recognized for improving neonatal outcome in our country. "Life cycle approach"

First Stage: Care of the Girl Child

Particularly in developing countries like India measures to improve newborn care should start from care of the girl child who is the future mother.

Her nutrition, immunization and education play a very crucial role in the well-being and outcome of her future progeny.

Second Stage: Care of the Adolescent Girls

Improving her nutritional status including anemia prevention, adequate immunizations including rubella

vaccine wherever possible, life cycle education, improving personal and reproductive hygiene, prevention of early marriages (Before 18 years of age), early motherhood (Before 21 years of age), improving general educational status are crucial for better neonatal outcome in future.

Third Stage: Care during Pregnancy

Essential minimum antenatal care includes following measures aimed at improving neonatal outcome.

- (a) Early registration of pregnancy
- (b) At least three antenatal check ups
- (c) Universal prophylaxis against nutritional anemia and tetanus.
 - Minimum of 2 injections of tetanus toxoids to be given at one monthly interval as early as possible during pregnancy. The second dose should have been given at least one month before the expected date of delivery.
- (d) Iron folic acid tablets through pregnancy and lactation period.
- (e) Identification of high-risk pregnancy and early referrals.
- (f) Promotion of institutional deliveries, which are well equipped and have trained persons.

High-risk pregnancy is defined as the one in which the mother is suffering from either a preconception adverse factor or an adverse factor become evident during the course of the pregnancy.

Examples of preconception or primary factors:

- Poor socioeconomic background
- Maternal malnutrition with weight under 40 kg. Height under 145 cm. and hemoglobin under 8 G%.
- Maternal age of less than 20 years (so called "teenage pregnancy") or over 35 years
- Primigravida
- Multigravida
- Bad obstetric history with abortions, stillbirth, difficult or operative deliveries, perinatal deaths, LEW, congenital malformations
- Rh negative mother
- Hypertension, diabetes mellitus, thyrotoxicosis heart disease and other systemic illness.

Examples of secondary factors are:

- Maternal infections
- Multiple pregnancy, especially second of twins
- Breech presentation, unstable lie and other abnormal presentations

- Cord presentation
 - Pregnancy induced hypertension
 - Toxemias
 - Rh isoimmunization
 - Poor fetal growth
 - APH
 - Hydramnios
 - Cephalopelvic disproportion
 - Fetal distress as indicated by exaggerated fetal movement, slow and irregular heart rate and visceral overactivity in the form of passage of meconium
 - Prolonged rupture of membranes (PRM)
 - Early onset of labor
 - All these high-risk factors during pregnancy and labor are determinates for neonatal problems like birth asphyxia, low birth weight or even still birth and many such dangerous neonatal outcomes.
- Prevention or early detection and management can improve the neonatal outcome in many ways.

Fourth Stage: Immediate Care at the Time of Delivery

- Clean and safe delivery by properly trained birth attendants including doctors, nurses or other category of health workers in a well equipped institution.
- Prompt and systematic resuscitation whenever indicated
- Adoption of minimum five cleans during every delivery
 - I. Clean surface
 - II. Clean hands
 - III. Clean cord tie
 - IV. Clean cord cut
 - V. Clean cord
- Maintenance of “warm chain” or measures to prevent hypothermia
- Promotion of early and exclusive breastfeeding preferably within ½ to 1 hour of birth for every normal newborn.

Fifth Stage: Routine Care of Newborn and Subsequent Follow up

- Warm chain
- Exclusive breastfeeding
- Measures to prevent neonatal infections
- Management of common problems of neonates

- Early detection of high-risk cases and management
- Safe and suitable referral to special care / intensive care centers
- Appropriate Immunizations
- Regular growth monitoring
- Developmental assessment and follow-up, if required.
- Health education to mothers
- Proper mother care techniques like feeding, bathing, infection prevention measures, etc.

At every stage, local traditional practices involving neonatal health should be studied in detail and then encourage the useful ones and stop the harmful ones. Some of them may be harmless. They may be allowed to continue till community persons realize its futility and stop them on their own.

BASIC PRINCIPLES OF ESSENTIAL NEWBORN CARE

1. To ensure adequate oxygenation through clear airways and proper breathing
2. To prevent hypothermia in the neonates
3. To encourage early and exclusive breastfeeding for healthy neonates or suitable method of providing nutrition to weak and sick babies who cannot feed on breast and get adequate nutrition.
4. Suitable measures to prevent neonatal infections.
5. Early identification of at-risk newborn, offer suitable initial management and stabilization of the baby if possible or arrange for safe transfer to suitable advanced neonatal care center.

For care of every baby, above mentioned principles should be followed and adapted according to the maturity and wellbeing of the baby.

THE 3-TIER SYSTEM OF NEONATAL CARE

Box 17.7 summarizes salient features of 3-tier system of neonatal care

DETERMINATION OF GESTATIONAL AGE

It is important to differentiate between the preterm and the IUGR babies. This has a bearing on management, including that of complications, and the prognosis.

Since the dates of last menstruation are frequently not forthcoming from the illiterate mothers,

Box 17.7: The 3-tier system of neonatal care

Level 1: This is meant for neonates weighing over 2,000 g or with a gestational age of 37 weeks or more. It is provided at home with guidance from basic health professionals such as a trained birth attendant (TBA). Its components are basic care at birth, maintenance of aseptic conditions, promotion of breastfeeding, etc.

Level 2: This is meant for neonates weighing 1,500 to 2,000 g or with a gestational age of 32 to 36 weeks. It is provided by experts at a district hospital, teaching hospital or a nursing home suitably equipped for intermediate care. Its components are resuscitation, incubator care, IV infusion, gavage feeding, phototherapy, exchange blood transfusion, etc.

Level 3: This is meant for neonates weighing less than 1,500 g or with a gestational age of 32 weeks. It is provided by specially trained neonatologists and nurses at neonatal intensive care units (NICU) with sophisticated facilities such as centralized oxygen and suction equipment, ventilators, infusion pumps, etc. In view of the exorbitant expenditure involved in setting up and maintenance of NICU, this type of care should be restricted to apex or regional perinatal centers only.

assessment of gestational age may be made on the basis of the physical and neurologic criteria.

Box 17. 8 presents the physical signs suggesting a gestational age < 37 weeks.

Box 17.8: Physical signs suggesting a gestational age of < 37 weeks**1. Genitalia***Male*

Small scrotum with few rugosities

Testes at external inguinal ring

Female

Widely separated labia majora with exposed labia minora and clitoris

2. Breast Nodule

< 5 mm diamer

3. Ear cartilage

Deficient with poor elastic recoil

Hair

Wooly (fine) or fuzzy (fluffy)

DANGER SIGNS

A healthy neonate is warm to touch, has pink palms and soles and feeds well. The signs listed in Box 17.9 point to existence of an illness. Presence of one or more of these signs is an indication for prompt evaluation.

Box 17.9: Danger signs warranting monitoring**General**

Poor feeding

Cold skin (hypothermia)

Pyrexia

Poor weight gain/excessive weight loss in first week

Bleeding

Pulmonary

Tachypnea (respiratory rate >60/min)

Chest retractions

Apnea/grunting

Gastrointestinal

True diarrhea

Persistent vomiting

Distention of abdomen

Failure to pass meconium within 24 hours

Neurologic

Seizures

Genitourinary

Failure to pass urine by 48 hours

Skin

Umbilical sepsis, pyoderma, sclerema

NEONATAL HYPOTHERMIA**Etiology**

The newborn, a preterm infant in particular, is highly susceptible to exposure to low environmental temperature. This can happen in situations such as:

1. Winter months,
2. Sudden change in weather conditions,
3. Resuscitation procedure, and
4. Cold snap.

Clinical Features

- Low body temperature (35 to 30°C or even less), cold skin with or without acrocyanosis(from peripheral vasoconstriction) , Further drop in temperature, say around 25°C, may cause *sclerema* (i.e. solidification of the subcutaneous tissue with the result that the skin feels hard and fixed to the underlying structures).
- lethargy, refusal to accept feed and bradycardia with pulse <60/min (from CNS depression).
- Hypoglycemia, hypoxia and metabolic acidosis (from high metabolism)
- Tachypnea and respiratory distress (from high pulmonary artery pressure)

- DIC may occur, leading to hemorrhagic manifestations including massive, pulmonary hemorrhage.
- Septicemia may further complicate the picture.

Treatment

Mild-Moderate Hypothermia (32-36° C)

- Immediate rewarming by skin-to-skin contact on a warm bed room in a warm room; may use radiant warmer, convection-warmed incubator

Severe Hypothermia (body temp < 32°C)

- Rewarming the infant using suitable facility (air-heated incubator, radiant warmer, thermostatically-controlled heated mattress)
- Slowly giving 10 to 20 ml of 25% glucose intravenously,
- Maintenance of electrolyte balance,
- Oxygen,
- Steroid therapy in case of sclerema,
- Vitamin K in case of bleeding and
- Exchange transfusion if DIC is the likely cause of hemorrhages,
- Antibiotics.

Prognosis

Mortality is in the range of 25 to 50%. Survivors show high incidence of brain damage.

Prevention (Measures for Warming The Baby)

Warm chain

The term is employed for a set of interlinked procedures aimed at preventing hypothermia in neonates at birth or later

1. Warm delivery room
2. Warm resuscitatio
3. Immediate drying
4. Skin-to-skin contact
5. Breastfeeding
6. Postponement of bathing (beyond 24 hours after birth)
7. Appropriate clothing and bedding
8. Nursing of baby and mother together
9. Warm transportation
10. Training and awareness of healthcare providers.

KANGAROO MOTHER CARE (KMC)

It is a very effective method of providing nursing and warmth through skin-to-skin contact to

preterms/LBW infants in developing countries (as a substitute for the expensive incubator) (Fig. 17.39).

Benefits

- Maintenance of infant's temperature
- Promotion of exclusive breastfeeding
- Promotes extrauterine adaptation
- Builds up mother's confidence
- Better growth
- Protection against infection
- Reduction in frequency of apneic spells
- Better mother-infant bonding.

Method

Essentially, the naked baby is placed between mother's breasts for skin-to-skin contact for many days at a stretch. Appropriate clothing is employed to hold the baby in position. During sleep, she maintains a semi-recumbent posture at an angle of 60 degree so that the baby remains upright. This assists in keeping the baby warm all times. He is made to feed at the breast on demand (minimal 2 hourly). In between, when she is take bath or take rest, father of some other amily member may do kangarooing. Else, the baby may be wrapped in a woolen clothing. KMC should be continued even after the discharge from the hospital until the baby has reached 2 kg weight.

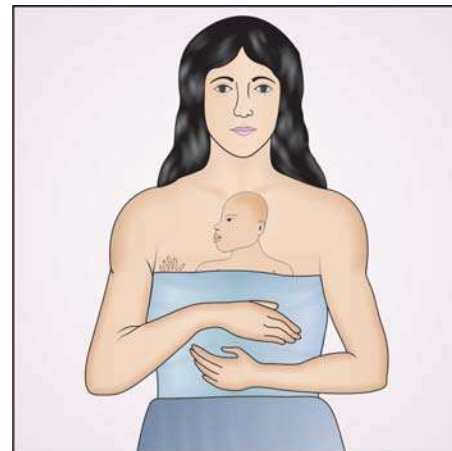

Fig. 17.39 : Kangaroo mother care (KMC): Note that the baby is held upright against the mother's skin and between the breasts and covered with mother's clothes plus an additional shawl/blanket. A belt around mother's waist may assist in keeping the baby in position

Prerequisites

- The neonates should have no medical problem or should have received initial stabilization

- The neonate should be able to breastfeed, at least partially
- The mother should be healthy and cooperative.

INCUBATOR CARE

A modern incubator, available in most specialized nurseries, is an excellent device to maintain temperature and humidity according to baby's requirements.

The recommended *nursery temperature* is around 30°C. The *incubator temperature* should be such as will maintain the axillary temperature of the baby between 35 to 37°C as clarified in Table 17.7.

A low reading rectal thermometer, graduated for 20 to 40° range, is a "must" for accurate recording of the baby's temperature.

Table 17.7: Incubator temperature setting

Weight of the baby	Recommended temperature
Below 1,000 g	35 to 36°C
1,000 to 1,500 g	32 to 35°C
1,500 to 2,000 g	30 to 32°C

A humidity of 60 to 70% suffices under most circumstances.

Lastly, an incubator infant should be left unclothed. This enables accurate observations of his general condition, color, respiration, etc. Further, such a baby should not be given bath.

Whereas an incubator is an excellent device for thermoregulation of ELBW and gravely sick neonates, its disadvantages include difficult access to the baby, difficulty in carrying out prolonged procedures such as exchange transfusion, high-risk of infection and high cost.

OPEN CARE SYSTEM

This is an economic alternative for the expensive incubator for providing microenvironment for high-risk neonates. Though it is not preferred for ELBW and gravely sick neonates, its positive points include easy access to the baby, less risk of nosocomial infection, most appropriate for doing prolonged procedures like exchange transfusion or surgery and affordable cost.

BREASTFEEDING

Once oxygenation and temperature is maintained, breastfeeding should be started within half to one

hour. It is best suited for a newborn. It is not only species specific but also baby specific. It contains all the nutrients for normal growth and development of a baby from time of birth to first six month of life.

Composition of Breast Milk

Energy	67 Kcal/dl.
Protein	0.9-1.3 gm/dl.
Fat	3.8-4.5gm/dl.
Carbohydrate	6.8 gm/dl.

Benefits of Breast Milk

- Adequate calories, easily digestible and bioavailable proteins and adequate amount of necessary fat.
- 88% of water with low osmolarity, thus decreasing the solute load on kidney.
- Prevents against infection.
- Helps in mental development and enhance bonding.

Breastfeeding should be initiated as soon as possible after birth (within ½ to 1 hour after vaginal delivery and 2-4hours after Cesarean Section). Colostrum should not be thrown away. Exclusive breastfeeding should be continued till 6 months of age. No gripe water no multivitamin drop should be given and complement food should be started after 6 months of exclusive breastfeeding. BF can be continued till child reaches 2 years of age. If the baby is not able to take direct breastfeeding than expressed breast milk (EBM) can be given through *katori* spoon (KS) or nasogastric tube.

Reflexes with Breastfeeding

- Rooting reflex: Helps baby to find the nipple and proper attachment to breast.
- Suckling reflex: Helps the baby draw out milk from mother's breast .It consist of:
 1. Drawing in the nipple and areola to form an elongated teat inside the mouth.
 2. Pressing the stretched nipple and areola with jaw and tongue against the palate.
 3. Drawing milk from lactiferous sinuses by wave like peristaltic movement of the tongue.
- Swallowing reflex

Technique of Breastfeeding

- *Position:* Comfortable position for mother and her baby either sitting or lying down. Baby's head and neck should be supported in a straight line with

his body and should face the breast. Baby's cheek should touch the mother's breast.

- *Latching*: It means attachment of nipple along with areola in baby's mouth and not nipple alone. Good attachment at breast is a key to successful breastfeeding to suckle effectively a baby should be well latched on the breast and should be able to take nipple and enough areola into the mouth for effective sucking.
- *Burping*: It means baby can be put on left shoulder the head has to be supported with mother's left hand and then with the right arm support the buttocks and gently pat on the baby's back with right hand. Is a must after feeding the baby to avoid regurgitation.
- *Adequacy of breastfeeding*: If the mother is confident, baby is passing urine 6-7 times a day, passing well formed stools, sleeping comfortably after feed for at least 2-3 hours at a stretch, gaining weight adequately.

Ten Steps of Successful Breastfeeding

- Have a written breastfeeding policy that is routinely communicated to all health care staff.
- Train all health care staff in skills necessary to implement this policy.
- Inform all pregnant women about the benefits and management of breast-feeding.
- Help mothers initiate breastfeeding within a half-hour of birth.
- Show mothers how to breastfeed and how to maintain lactation even if they should be separated from their infants.
- Give newborn no food or drink other than breast milk, unless medically indicated.
- Practice rooming-in: Allow mothers and infants to remain together 24 hours a day.
- Encourage breastfeeding on demand.
- Give no artificial teats or pacifiers (also called dummies or soothers) to BF infants.
- Foster the establishment of breastfeeding support groups and refer mothers to them on discharge from the hospital or clinic.

FEEDING THE LOW BIRTHWEIGHT (LBW) INFANT

This is detailed in Chapter 12 (Infant Feeding).

HYPOXIC-ISCHEMIC ENCEPHALOPATHY (Perinatal Asphyxia)

The term, *hypoxia*, means inadequate arterial oxygen concentration and, *ischemia*, inadequate blood flow to cells or organs so that their normal functioning suffers. This encephalopathy is an important cause of neonatal death, cerebral palsy or mental retardation.

Etiopathogenesis

Two major groups are recognized: fetal hypoxia and postnatal hypoxia (Table 17.9).

The fundamental insult, perinatal hypoxia and birth asphyxia, initiate a spectrum of neuronal biochemical alterations and alterations in cerebral perfusion, leading to selective necrosis of the neurons of deeper cerebral cortical layers with the resultant various neurologic manifestations of HIE. A notable feature is that whereas in full-term babies major area of involvement is parasagittal cerebral, in case of preterm babies it is deeper periventricular white matter.

Nonbrain involvement includes damage to CVS (CCF, myocardial ischemia), kidneys (acute tubular necrosis, SIADH), GIT (NEC), blood (DIC), liver and lungs (reduced surfactant, persistent pulmonary hypertension, pulmonary edema, pulmonary hemorrhage).

Clinical Features

Before delivery, manifestations include IUGR, slowing of fetal heart rate with variable or late deceleration pattern, and acidosis in scalp blood analysis. To safeguard against fetal death or CNS damage to the infant, mother must be administered high concentration of oxygen and the delivery conducted immediately.

At delivery, meconium staining of the amniotic fluid indicate fetal distress. Manifestations in these infants include failure to breath spontaneously, hypotonia, change from hypotonia to hypertonia, pallor, cyanosis, slow heart rate, unresponsiveness to external stimuli, seizures, CCF, cardiogenic shock, respiratory distress syndrome, persistent pulmonary hypertension, gastrointestinal perforation, hematuria and acute tubular or cortical necrosis.

After delivery hypoxia is characterized by dyspnea and cyanosis, in particular, appearing within minutes

of birth and is secondary to respiratory failure and circulatory insufficiency.

Box 17.10 gives the time-honored Sarnat and Sarnat staging system for HIE.

Box 17.10: Sarnat and Sarnat staging of hypoxic-ischemic encephalopathy (HIE)

Signs	Stage 1	Stage 2	Stage 3
Level of consciousness	Hyperalert	Lethargic	Stuporous, coma
Muscle tone	Normal	Hypotonic	Flaccid
Posture	Normal	Flexion	Decerebrate
Tendon reflex	Hyperactive	Hyperactive	Absent
Myoclonus	Present	Present	Absent
Moro reflex	Strong	Weak	Absent
Pupils	Mydriasis	Miosis	Unequal, poor light reflex
Seizures	None	Common	Decerebration
EEG	Normal	Low voltage changing to seizure activity	Early periodic pattern, later totally isopotential
Duration	< 24 hr	2-14 days	Days to wk
Outcome	Good	Variable	Death, severe deficits

Differential Diagnosis

A large number of conditions fall in the differential diagnosis of HIE. These include hypoglycemia, sepsis, severe hyperbilirubinemia, ICH, idiopathic cerebral infarction, congenital neuromuscular diseases, congenital dysmorphic syndromes and inborn errors of metabolism.

Diagnosis

Clues in the history and a thorough neurologic examination may be supported by EEG, visual-evoked responses (VER), brainstem auditory-evoked responses (BAER), cranial sonography, CT scan, MRI, nuclear magnetic resonance spectroscopy (MRS), near infrared spectroscopy (NIRS), single photon emission computed tomography (SPECT), positional emission tomography scan (PET) and intracranial pressure measurements.

Treatment

It consists in restricting fluids to 2/3rd of the total maintenance requirement, correction of hypoglycemia (maintaining blood glucose at 75-100 mg/dl),

hypocalcemia and acidosis, control of seizures and provision of hyperventilation with 100% oxygen in order to maintain PaO₂ at 100-200 torr. In addition, the infant must be kept warm and his blood pressure maintained. Potassium needs to be avoided during first 24 hours.

New therapeutic modalities include:

1. Prevention of free radical formation (allopurinol and its active metabolites)
2. Free radical elimination (antioxidant enzymes, antioxidant free scavengers such as vitamin E)
3. Excitatory amino acid antagonists
4. Calcium channel blockers (flunarizine, nimodine)
5. Substrate availability (glucose supplementation), and
6. Hypothermia (induced by cooling the head employing ice-helmet).

Prevention

Careful monitoring of the fetus during labor and prompt and appropriate intervention at the earliest sign of fetal distress constitutes the hallmark of prevention of hypoxic-ischemic encephalopathy.

Prognosis

Untreated severe HIE proves fatal in almost 30% of the cases.

The following features are accompanied by bad prognosis:

1. Severe encephalopathy characterized by flaccid coma, apnea, absent oculocephalic reflexes, refractory seizures and significant reduction in cortical attenuation on CT scan
2. Prematurity
3. Inability to control metabolic and cardiopulmonary complications like hypoxia, hypoglycemia, shock, etc.
4. A low Apgar score at 20 minutes
5. Absence of spontaneous respiration and persistence of abnormal neurologic signs at 2 weeks of age.

Long-term Sequelae

These include impaired attention span, hyperactivity, mental retardation, cerebral palsy (spastic diplegia or quadriplegia, choreoathetosis, ataxia), bulbar and pseudobulbar palsies, auditory deficits and seizures.

Table 17.8: Scoring system for respiratory distress syndrome

Score	0	1	2
Respiratory rate	<60	60 to 80	80 or apnea
Cyanosis	None in room air	in 40% oxygen	in more than 40% oxygen
Retraction	None	Mild	Moderate or severe
Grunting	None	Audible with stetho	Audible without stetho
Air entry (crying)	Clear	Decreased	Barely audible

Note:	Score	Action needed
	0 to 4	less than 40% oxygen
	5 to 7	CPAP
	Over?	assisted ventilation

RESPIRATORY DISTRESS SYNDROME

A neonate is said to be suffering from respiratory distress

- when he has tachypnea with a respiratory rate of 60/minute or more, when quiet, and,
- when he has an inspiratory costal retraction or expiratory grunt, with or without cyanosis.

In each and every infant with respiratory distress, it becomes mandatory to assess the gravity of the situation and to determine the factor(s) underlying the problem. Only then, one can initiate right type of management.

Table 17.8 gives a scoring system for assessing the severity of the respiratory distress.

As is evident from an appraisal of Table 17.9, a large number of conditions can cause respiratory distress in a newborn.

Here the details will be limited to idiopathic respiratory distress syndrome (IRDS) or *hyaline membrane disease* (HMD).

HYALINE MEMBRANE DISEASE (HMD)

HMD is not as infrequent in India as has been held over the years. Undoubtedly, its incidence is much higher in the West where it is the top most cause of neonatal respiratory distress and mortality. In India, incidence appears to be 1% among live births, rising to about 8% among preterm infants.

Table 17.9: Causes of hypoxic-ischemic encephalopathy

Fetal Hypoxia

- Hypoventilation during anesthesia, cardiac failure or carbon monoxide poisoning leading to inadequate oxygenation of maternal blood.
- Spinal anesthesia or compression of vena cava and aorta by gravid uterus leading to maternal hypotension. Uterine tetany from excessive use of oxytocin leading to poor relaxation of the uterus and poor placenta) filling.
- Premature separation of placenta.
- Compression or knotting of the umbilical cord, leading to impedance to the circulation of blood through the cord.
- Cocaine causing uterine vessel vasoconstriction
- Toxemias and postmaturity leading to placental insufficiency.

Postnatal Hypoxia

- Anemia from severe bleeding or hemolytic disease
- Shock from adrenal hemorrhage, IVH, fulminant infection or massive blood loss
- Poor arterial oxygen saturation from cerebral defects, necrosis or injury
- Poor oxygenation of blood from cyanotic CHD or deficient pulmonary function.

Etiopathogenesis

As the name indicates, exact etiology is not known. Reduction or absence of a substance, called surfactant, that normally covers the surface epithelium of the air passages, is said to be the fundamental lesion. As a result, alveolar collapse and lack of adequate expansion occur. Pulmonary capillaries secrete fibrin that gets precipitated to form eosinophilic hyaline membranes over the bronchioles and alveoli. These membranes make the exchange of gases in the lungs difficult.

The earlier impression that aspiration of amniotic fluid plays a significant role in causation of HMD is now found to be erroneous.

HMD is principally a disease of preterm babies, born to diabetic mothers, after Cesarean section, or following intrauterine respiratory distress. It is never seen in full-term babies even though they may be SFD.

Clinical Features

The disease usually manifests right at birth (in some cases symptoms may be delayed for a few hours, often 6 hours) with progressively increasing respiratory distress. Grunting respiration, flaring of alae nasi, retraction of ribs and sternum and cyanosis are usually prominent. Low blood pressure, hypothermia and

hemorrhagic manifestations (DIC, pulmonary hemorrhage, intraventricular hemorrhage) hypoglycemia, gross metabolic disturbances, CCF, pneumothorax, respiratory infection, etc. may complicate the clinical picture.

Auscultatory findings are poor air entry and widespread crepitations over both lungs.

Diagnosis

X-ray chest reveals ground-glass appearance and prominence of bronchial air shadows, the so-called *air bronchogram* pattern, extending beyond the left border of the heart. An X-ray taken at a later stage may show the lung field as absolutely opaque. Generalized but patchy atelectasis occurs little later.

A negative gastric aspirate shake test, provided that the gastric aspirate is not contaminated with blood or meconium, supports the diagnosis.

Definitive diagnosis is only possible at autopsy which shows, among other findings, lungs with liver-like consistency and a hyaline membrane uniformly lining the respiratory bronchioles.

Prevention

HMD can be suspected intranatally in susceptible situations (maternal diabetes) by the following tests:

- Lecithin/sphingomyelin ratio in the amniotic fluid under 1.5 (a ratio exceeding 2 signifies maturity of the lung).
- Amniotic fluid shake test/density by spectrophotometry, if negative.
- Phosphatidyl glycerol, if absent. This is the most specific and most reliable test for testing the lung maturity and, thus, diagnosing HMD during intrauterine life.

All possible efforts must, therefore, be made by the obstetricians to avoid premature labor so that gestational and pulmonary maturity is attained.

Other measures, especially in unavoidable premature induction of labor and diabetic mothers with risk of premature delivery include

- Administration of steroids (dexamethasone or betamethasone) 48 to 72 hour before delivery in case of fetuses of 32 week or less gestation, especially if lecithin in amniotic fluid indicates immaturity of the fetal lungs

- Administration of one dose of surfactant into trachea of premature neonates during 24 hours after birth. It reduces mortality from HMD.

Differential Diagnosis

A large number of conditions (Table 17.10) need to be considered in the differential diagnosis of HMD.

Table 17.10: Causes of neonatal respiratory distress

Maternal	: Toxemia, severe anemia, cardiovascular disease, abnormal uterine contractions, anesthesia or drugs
Obstructive	: Aspirated material, macroglossia, gloss-optosis, choanal atresia, vascular rings pressing on trachea, goiter, diaphragmatic hernia, tracheoesophageal fistula
Pulmonary	: Idiopathic respiratory distress syndrome, pneumonia, pneumothorax, pneumomediastinum, pulmonary edema or hemorrhage, pleural effusion, atelectasis, Wilson-Mikity syndrome*, bronchopulmonary dysplasia*, wet-lung syndrome**
Neurologic	: Central depression due to birth trauma, anesthesia, drugs, intracranial hemorrhage, phrenic nerve paralysis, intercostal muscle paralysis as in congenital poliomyelitis, Werdnig-Hoffmann disease, myasthenia gravis
Cardiac	: Congestive cardiac failure
Metabolic	: Acidosis, alkalosis, organic acidemia

* These two conditions occurring in SFD, appear to result from oxygen toxicity. The prognosis is poor. Many of the affected infants die from a progressive respiratory illness like cor pulmonale or CCF.

** This almost benign condition is characterized by perihilar congestion and clears on its own in 2 to 4 days. Poor lymphatic clearing of alveoli appears to be the cause. The other name given to this condition is transient tachypnea of the newborn.

Of special interest is the early-onset Group B streptococcal infection (the late-onset group B streptococcal infection causes meningitis). Important differentiating points are:

- The disease is manifested with dyspnea, apnea and shock, nearly always before the infant is 3 hours old. HMD manifests during the first 6 hours
- Prolonged rupture of membranes (PRM) and maternal febrile illness are usually present whereas these are unusual for HMD
- Course of disease is short and fulminant whereas it is variable in HMD

- X-ray chest may show, in addition to the findings seen in HMD, lower lobe opacities and exaggerated interstitial markings
 - Gastric aspirate cytology shows polyp and streptococci. In HMD, it is negative.
2. Prenatal steroid (betamethasone, dexamethasone or glucocorticoid) therapy
 3. Surfactant (endotracheal) first dose to symptomatic premature infants soon after birth or during the first few hours of life (*early rescue*).

Treatment

The patient should be treated in a *humidified incubator*. Oxygen flow should be so regulated as to maintain the arterial oxygen concentration between 70 to 90 mmHg. The oxygen should be cut down as soon as possible to minimize the danger of retrolental fibroplasia and/or bronchopulmonary dysplasia. Humidity should be 60 to 80% in the incubator. The rectal temperature needs to be kept around 36.5°C. If the baby continues to be “bad”, continuous positive airway pressure (CPAP) by a respirator, a mask or intranasal tube should be given. If, despite 100% oxygen or CPAP, the infant shows poor response, assisted ventilation—a very expensive, sophisticated and specialized modality—may be resorted to by an expert.

The use of *intravenous fluids*, especially 1 to 2% sodium bicarbonate in 5 or 10% dextrose in water, to counter acidosis, is of value. Its dose is 3 to 5 mEq/kg in 24 hours. It is better if the dose of sodium bicarbonate can be monitored by the pH of the arterial blood. For instance, the dose for a pH of less than 7.00 is 7 mEq/kg whereas for a pH of 7.25 to 7.30 it is only 1 mEq/kg.

Broad spectrum antibiotic cover (say ampicillin/cefotaxime plus gentamicin) should be given for underlying/superadded infection.

Indomethacin, 0.2 mg/kg (0, IV) may be given 12 hourly for a total of 3 doses for the associated PDA which can worsen existing hypoxemia.

Exogenous surfactant, instilled endotracheally, yields gratifying results. Natural surfactants (derived from animal source, say calf) are superior because of their surfactant-associated protein content. Therapeutic indication for surfactant is VLBW infants needing 30% oxygen and mechanical ventilation (*rescue therapy*).

Exchange transfusion has a debatable role in the management of HMD.

Prevention

1. Avoidance of premature deliveries and, thereby prevention of pulmonary immaturity.

Prognosis

HMD carries a bad prognosis. If the baby tides over first 2 to 5 days, natural remission (heralded by spontaneous diuresis) may occur. The survivors may suffer from neurologic, pulmonary or ophthalmic sequelae.

MECONIUM ASPIRATION SYNDROME (MAS)

About 13% of all deliveries have meconium staining of amniotic fluid (MSAF). Around 6% of such neonates aspirate meconium into the lungs *in utero*, during delivery or immediately after birth, and develop respiratory distress. This is termed *meconium aspiration syndrome* (MAS).

Clinical Features

The most common presentation is a postmature and SFD infant with staining of nails, skin and umbilical cord with meconium and neurological and respiratory depression followed by varying degree of respiratory distress that may persist for several weeks.

Complications

- Airleak syndromes: Pneumothorax, interstitial emphysema, pneumomediastinum, pneumopericardium, pneumoperitoneum, subcutaneous emphysema.
- Persistent pulmonary hypertension of the newborn (*vide infra*).
- Hypoxic-ischemic encephalopathy.
- Pulmonary/cerebral hemorrhage.
- Superadded bacterial sepsis.
- Subglottic stenosis (due to prolonged endotracheal intubation).

Diagnosis

Chest radiograph shows overinflated lungs, flat diaphragm, retrosternal lucency, segmental collapse, bilateral pneumonia and signs of air leak syndromes. Cardiomegaly may also be present.

Treatment

MAS with mild respiratory distress shows encouraging response to (intravenous) IV infusion and oxygen. MAS with severe respiratory distress needs ventilatory support (including high frequency ventilation as a rescue therapy). Role of steroids, antibiotics and surfactant therapy is controversial. In selected situations, extracorporeal membrane oxygenation (ECMO) is life-saving.

Prevention

All infants with evidence of MSAF should have oropharyngeal suction before delivery of shoulder and endotracheal suction under laryngoscopic visualization after delivery (but before he takes his first breath) in order to safeguard against meconium aspiration into the lungs.

PERSISTENT PULMONARY HYPERTENSION OF THE NEWBORN (PPHN)

The term refers to severe respiratory distress as a result of persistent elevation in pulmonary resistance due to failure of normal circulatory transition at birth when pulmonary vascular resistance (PVR) falls drastically and systemic vascular resistance (SVR) increases, triggering closure of ductus arteriosus and foramen ovale. The PVR remains high and SVR low. The result is right to left shunt across the foramen ovale, manifesting as persistent central cyanosis.

Echocardiography assists in differentiating it from cyanotic congenital heart disease.

Treatment is in the form of ventilatory support and medication with vasodilators such as nitric oxide, tola-zoline, magnesium sulfate, adenosine, nitroglycerine, calcium channel blockers and bicarbonate and intropes. Prognosis is unfavorable.

TRANSIENT TACHYPNEA OF THE NEWBORN (TTN)

The term refers to a benign self-limiting condition secondary to delayed clearance of lung fluid that may cause tachypnea or minimal respiratory distress usually in full-term neonates delivered by cesarean section. Chest radiograph shows prominent vascular markings and interlobar fissure.

Treatment is only symptomatic measures which lead to excellent outcome.

NEONATAL SHOCK

The term denotes a clinical state of poor perfusion of the body tissues so much and so that the body demands are not adequately met as a result of either great increase in oxygen consumption and/or great decrease in oxygen delivery.

Etiopathogenesis

The fundamental problem is sudden fall in arterial blood pressure as a result of factors affecting the cardiac output or myocardial contractibility (severe hypoxia, toxins, anaerobic metabolites, toxins, hyperkalemia) and peripheral circulatory resistance (vascular wall tone and viscosity, blood volume). The immediate response of body is to shunt blood to brain and myocardium and to cut down blood supply to skin, kidneys and GIT through vasoconstriction.

Table 17.11 gives the broad etiology of neonatal shock.

Classifications

- A. *Etiologic*: Hypovolemic, distributive and cardiogenic
- B. *Based on magnitude of cardiac dysfunction*: Compensated, decompensated and irreversible
- C. *Based on cardiac output and flow*: Low cardiac output and high cardiac output

Table 17.11: Etiology of neonatal shock

Hypovolemic Shock

Blood loss: Antepartum (twin to twin transfusion, fetomaternal transfusion, placenta previa), Intrapartum (ICH, birth trauma, excessive bleeding, umbilical vessels), Postpartum (DIC, IVH)

Fluid and electrolyte loss: Vomiting, diarrhea, phototherapy, hyperthermia, poor fluid intake, iatrogenic renal disease, abdominal surgery

Distributive Shock

Infections: Septicemia

CNS: Trauma (neurogenic shock), HIE

Drugs: Phenobarbital, muscle relaxants, anesthetics

Cardiogenic Shock

Myocardial Dysfunction: CCF, viral myocarditis, cardiomyopathy, arrhythmias, myocardial depressants (hypoglycemia, acidosis, sepsis)

Outflow (Mechanical) Obstruction: Pneumo- or hemo-pericardium, tension pneumothorax, diaphragmatic hernia, severe interstitial emphysema, pulmonary embolism

Congenital Heart Disease: TOF (severe), TOGA, HLHS, TA, PDA, AS, COA, PA with intact ventricular septum.

D. *Advanced trauma life support classification*: Class 1: Upto 15% blood loss, class 2: 20-25% blood loss, class 3: 30-35 % blood loss, class 4: 40-50% blood loss.

Clinical Features

These include marked pallor despite adequate hematocrit, lethargy, irritability, hypotonia, circumoral grayish discoloration, cold-clamy skin of limbs, difference of $> 2.5^{\circ}\text{C}$ between core and surface temperatures, capillary refill time > 2 seconds, tachycardia, tachypnea and sclerema. In addition, systemic manifestations due to involvement of CNS, CVS, respiratory system, GIT and kidneys may be present.

Complications

These include DIC, shock lung, ARF, NEC, hemorrhage (pulmonary, IVH, PVH).

Diagnosis

It is based on a carefully recorded history and physical examination with special reference to predisposing causes, blood pressure (intraarterial line should be preferred over Doppler method), focus of infection, peripheral circulation and cardiopulmonary status. Special investigations include hematocrit, CBC, coagulation profile, serum calcium, glucose, BUN, creatinine, blood culture and sepsis screen, pulmonary artery catheterization for LFT, CVP, LAP and SVR, arterial blood gases, ECG, chest X-ray and echocardiography.

Treatment

Aggressive therapeutic approach consists in maintaining CVP at 5-8 cm of water, monitoring heart rate, oxygenation and BP round the clock, correcting hypoxia, acidosis or hypoglycemia, correcting dyselectrolytemia, blood transfusion, vitamin K, antibiotics, inotropic drugs (digoxin, dopamine, isoproterenol, dobutamine), massive doses of steroids. Direct current cardioversion in case of cardiogenic shock and pericardiocentesis in case of pneumopericardium are indicated.

Prognosis

With modern treatment, around 50% patients can be saved.

RECURRENT NEONATAL APNEA (Apneic Spells)

This condition is characterized by intermittent respiratory pause for more than 20 seconds or apnea (sudden cessation of respiration) followed by cyanosis, bradycardia and limpness with unresponsiveness to tactile stimuli.

Etiopathogenesis

Predisposing conditions include low birth weight (under 1,500 g) and/or gestation under 32 weeks, HMD aspiration, pneumonia, pulmonary hemorrhage, congenital heart disease, birth trauma, maternal sedation, accidental injection of local anesthetic during labor, tracheoesophageal fistula, diaphragmatic hernia, choanal atresia, Pierre Robin syndrome, hyperbilirubinemia, hypoglycemia, acidosis, dehydration, septicemia and methemoglobinemia.

Triggering factors include frequent handling, environmental heat, rapid reawakening, vigorous suction, sudden flexion of neck, and lung inflation (head paradoxical reflex).

The fundamental pathologic defect appears to be an immaturity of the medullary respiratory center which lacks effective respiratory drive.

Diagnosis

It is primarily clinical. Such conditions as periodic breathing, cyanotic spells, convulsions, esophageal atresia, HMD, aspiration pneumonia, diaphragmatic hernia, and congenital heart disease should be considered in the differential diagnosis.

Treatment

If cutaneous stimulation and artificial respiration fail to initiate breathing, a respiratory stimulant, theophylline 5 mg/kg (IV) followed every 8 hourly by 2 mg/kg (IV or O) may bring about gratifying response. Caffeine citrate (IV) is an equally good alternative.

Doxapram, 1-2.5 mg/kg (IV infusion), may prove effective in apnea refractory to xanthines.

Supportive measures include nursing in an incubator to maintain temperature at the lower end of the environment range, oxygen inhalation, IV drip of 10% glucose, correction of hypoglycemia, hypocalcemia, acidosis and antibiotic therapy when apneic attacks manifest after 3 days of birth.

Prognosis

Survivors, especially with immaturity, show high incidence of brain damage.

STRIDOR

See Chapter 38 (Pediatric ENT Problems).

INFECTIONS IN THE NEWBORN

Quite a number of factors contribute to uniqueness of neonatal infections (Box 17.11).

Box 17.11: Factors contributing to uniqueness of neonatal infections

- Diverse modes of transmission from mother to the fetus or neonate: hematogenous transplacental, vertical postnatal
- Disturbed immunocompetence leading to reduced capability to respond to infection
- Coexistence of one or more diseases of the neonate complicating the diagnosis and treatment of infection
- Remarkably variable manifestations of neonatal infections, the expression depending on time of exposure *in utero*, size of inoculum, immune status and etiologic agent.

The term, *intrauterine infection*, refers to infection acquired *in utero*. The TORCH (more appropriate STORCH) group of infections (syphilis, toxoplasmosis, others like HIV, HBV, etc, rubella, *cytomegalovirus*, and herpes simplex) belong to this category.

The term, *perinatal infection* refers to an infection that is acquired just before or during delivery from the mother. Such an infection may occur from the organisms colonizing the birth passage (group B streptococci, gonococci, *E. coli*, *L. monocytogenes*, *Chlamydia*, *Mycoplasma*, herpes simplex and enteroviruses), or as a result of maternal-to-fetal transfusion at delivery (HBV and HIV). The bacterial invasion of the amniotic fluid, usually as a consequence of prolonged rupture of membranes, is termed *amniotic infection syndrome*. Besides this syndrome, difficult or traumatic delivery as also premature delivery may also be accompanied by perinatal infections.

At times, a perinatal infection may actually manifest after some interval following birth.

The term, *early neonatal infection*, should be limited to perinatal infection with manifestations occurring within 72 hours of birth.

The term *late-onset infection* is applied to sepsis occurring after 8th day.

The term, *postneonatal infection*, refers to infection acquired after 28 days of life.

Prematurity and low birth weight, intubation and umbilical catheterization are accompanied by an increased risk of bacterial infection. This kind of infection is also called *late-onset neonatal infection*. Neonatal infections that develop later than 48 to 72 hours after birth and during stay in the hospital are considered “nosocomial”.

The organisms responsible for postnatal neonatal infection include *E. coli*, *Klebsiella*, *Pseudomonas*, *Aerobacter*, enterococci, *Proteus*, *Staphylococcus aureus* and *Candida*. Umbilicus is the most common route of entry of the organism into the body. Alternatively, it may invade the body through skin or mucosa.

Table 17.12 outlines predisposing factors for postnatal neonatal infections.

Table 17.12: Predisposing factors for neonatal infections

- Low birth weight/prematurity
- Contaminated environments in uterus
- Infected birth passages → Infected postnatal environments
- Congenital anomalies
- Hospital procedures
- Artificial feeding
- Male sex

Table 17.13 outlines preventive measures for nosocomial neonatal infections.

CONGENITAL SYPHILIS

Maternal syphilis, even in first trimester, may cause transplacental infection to the fetus, the risk being almost 100%. During passage through the birth canal; risk is certainly there but only minimal.

Clinical Features

In the first place, syphilis may cause still birth or hydrops fetalis.

Early manifestations include skin lesions (bullous, maculopapular or condylomatous over palms and soles), rhinitis or snuffles (frequently blood-stained discharge), jaundice, hepatosplenomegaly, generalized lymphadenopathy. Coombs negative hemolytic anemia, thrombocytopenic purpura, bony lesion (osteitis, osteochondritis, pseudoparalysis

Table 17.13: Prevention of postnatal neonatal infections (nosocomial)

- Proper washing of hands and forearms with soap and water.
- A 2-minute scrub before entering nursery, 15-second scrub between two neonates, are strongly recommended
- Avoidance of overcrowding
- Minimum handling of the infants
- A check on the entry of individuals harboring infection, including carriers, into the nursery
- Change in hand-washing solutions and protocols
- Proper cleansing and maintenance of nursery
- Equipment sterilization
- Proper cleansing of babies, and the cord care in particular
- Use of separate/disposable kits for infants
- Chemoprophylaxis as and when indicated
- Breastfeeding

usually unilateral involving upper-limbs), and perioral and perianal ulcerations. Intrauterine growth retardation is invariably present. Head may be microcephalic or hydrocephalic.

Late manifestations seen after age of 2 years, include interstitial keratitis, frontal bossing, saber shins and tooth changes.

Diagnosis

It is based on clinical suspicion, examination of placenta, serology (VDRL, FTA-ABS, FTA-ABS-IgM on mother and infant, and hematology, radiology of bones and CSF.

Treatment

If CSF is normal, procaine penicillin, 50,000 units/ kg/ day (IM) for 10 to 14 days suffices.

If CSF is abnormal, crystalline penicillin, 100,000 to 150,000 units/kg/day in 2 or 3 divided doses (IM, IV) for at least 10 days is required.

CONGENITAL TOXOPLASMOSIS

Congenital toxoplasmosis usually occurs when the infection is acquired by an immunologically normal pregnant woman. Though fetal manifestations are severest early in gestation, the rate of transmission is least early in gestation and highest later in gestation.

Clinical Features

If the fetus escapes abortion, a wide variety of manifestations involving different systems may be encountered.

Neonatal manifestations include low birth weight, hepatosplenomegaly, jaundice, anemia, meningoencephalitis, thrombocytopenic purpura and fever.

Congenital defects include hydrocephalus or microcephaly.

Late sequelae include chorioretinitis and mental retardation.

Diagnosis

The protozoon may be demonstrated in the CSF or tissues.

Additional tests include specific IgM indirect fluorescent antibody, paired maternal and cord sera for complement fixation and hemagglutination inhibition tests.

Treatment

A combination of pyrimethamine and sulfadiazine plus folinic acid should be administered for 1 year. Steroids are indicated in the presence of inflammatory lesions such as chorioretinitis involving the macula, CSF protein above 2 g/dl at birth or a generalized infection.

Prevention

The pregnant women must avoid contact with oocytes excreted by cats and eat only well-cooked meat.

Serologic screening and ultrasound monitoring of pregnant women contributes to prevention of congenital toxoplasmosis.

Treatment of maternal toxoplasmosis with spiramycin (not pyrimethamine and sulfadiazine which are known teratogenics) is yet another vital preventive measure.

CONGENITAL RUBELLA

There are two peaks for maternal rubella to infect the fetus, causing embryopathy—first 4 weeks of gestation (risk 50%) and after 26 weeks (risk 75%), the former being responsible for most florid embryopathy.

Clinical Features

Rubella embryopathy may end up as abortion. Neonatal manifestations include low birth weight, hepatosplenomegaly, icterus, hemolytic anemia, thrombocytopenic purpura, petechiae or maculopapular rash, and osteitis.

Congenital defects include cardiovascular malformations, microcephaly, cataracts and microphthalmia.

Late sequelae include deafness, mental retardation, thyroid disorders, diabetes mellitus, degenerative brain disease, infantile autism, etc.

2 Diagnosis

Isolation of the agent is possible from throat swab, urine and CSF.

Additional tests include cord serum for IgM and specific IgM fluorescent antibody, paired maternal and cord sera for complement fixation, and neutralizing and hemagglutination inhibition titers.

Prevention

The only foolproof means of prevention of congenital rubella is vaccination of the girls before puberty.

CYTOMEGALOVIRUS DISEASE

Transmission of the CMV from mother to fetus may occur at any stage of pregnancy.

Neonatal manifestations include low birth weight, hepatosplenomegaly, jaundice, petechiae, anemia, thrombocytopenic purpura, encephalitis and respiratory distress from pneumonia.

Congenital defects include microcephaly, microphthalmia and retinopathy.

Late sequelae include deafness, psychomotor retardation, seizures, and cerebral calcification.

Diagnosis

The organisms may be isolated from freshly voided urine, throat swab and leukocytes.

Additional tests include specific IgM fluorescent antibody, cytomegalic inclusion cells in urine, paired maternal and cord sera for complement fixation.

Treatment

As yet no satisfactory treatment is available. The mortality is, therefore, high.

Prevention

The search for an effective CMV vaccine is in progress.

HERPES SIMPLEX

HSV, usually type 2 and occasionally type 1, generally infects the infant during intrapartum period following

contamination by infected external genitalia. A proportion of the infants acquire the infection during intrauterine life, or from mother or caretaker during postnatal period.

Clinical Features

Abortion may be the outcome of the infrequent fetal infection occurring early in pregnancy.

Three clinical patterns of neonatal infection are known, namely (i) disseminated, (ii) skin-eye-mouth disease, and (iii) encephalitic disease.

Disseminated disease is characterized by multiorgan involvement with lesions in skin, lungs, trachea, CNS, esophagus, kidney, adrenals, spleen, heart, etc. Manifestations, which start from 4th to 10th day after birth, mimic fulminant septicemia. These include fever, apnea, respiratory distress, seizures, lethargy, irritability, conjugated hyperbilirubinemia, shock, DIC and vesicles.

Skin-eye-mouth disease is characterized by cutaneous vesicles and ocular lesions (keratoconjunctivitis, late chorioretinitis, microphthalmia, cataracts). If not treated with antiviral therapy, this type may progress to disseminated disease.

Encephalitic disease (isolated), due to retrograde axonal transmission of virus to CNS and not viremia, is characterized by pyrexia, irritability, lethargy, change in sensorium (even coma), seizures, bulging fontanel, high-pitched cry and focal temporal lobe lesions on CT scan, or EEC.

Diagnosis

HSV can be isolated in tissue cultures obtained from vesicles, nasopharyngeal or throat swabs, urine, stool, tracheal secretions, duodenal aspirate and CSF.

Additional tests include specific fluorescent antibody, CMV inclusion cells in urine, paired maternal and cord sera for complement fixation antibody.

Treatment

Two antiviral agents, acyclovir and vidarabine, are recommended. Acyclovir is particularly superior to vidarabine in HSV encephalitic disease.

Topical antiviral agents for ophthalmic involvement include vidarabine, idoxuridine and trifluorothymidine.

Prevention

Mothers with genital herpes should have delivery by cesarean section. The latter should preferably be done within 4 to 6 hours of rupture of membranes.

Prognosis

Disseminated and encephalitic herpes have worse prognosis than skin-eye-mouth herpes. HSV type I encephalitis has better outcome than HSV type 2 encephalitis.

PERINATAL AIDS

A HIV-positive mother may pass on the infection to the infant *in utero*, during delivery or through breastfeeding. The risk following breastfeeding is only 14% but the overall risk varies from 50 to 60%. Existence of vitamin A deficiency in the mother boosts the risk of vertical transmission 3 to 4 times.

Usually, the infant is asymptomatic at birth and may remain so during the first 6 months. The facial dysmorphism includes hypertelorism, prominent box-like forehead, short nose with depressed bridge of nose, oblique eyes with long palpebral fissures and blue sclerae, patulous lips and prominent triangular philtrum. Differential diagnosis should include fetal-alcohol syndrome and familial traits.

Seropositivity alone, unless it persists beyond 15 months, cannot be counted for establishing diagnosis of perinatal HIV infection. On the other hand, actually infected infants may turn out to be seronegative at 15 months. The ELISA and Western blot tests, therefore, have limited diagnostic value in perinatal AIDS.

Culture and polymerase chain reaction (PCR) are recommended for early and dependable diagnosis of perinatal HIV infection.

Good nursing care and good nutrition constitute the mainstay of management of perinatal HIV infection. Exclusive breastfeeding in the underprivileged needs to be continued because of its unmatched nutritive and anti-infective values and only limited risk of passing the HIV to the baby. To safeguard against intercurrent infections, IV immunoglobulins are advocated. Cotrimoxazole as a prophylaxis against *Pneumocystis carinii* is in order. To prevent *Candida esophagitis*, oral application of ketoconazole early in course of disease may be helpful.

The use of specific antiviral agent, azidothymidine (AZT, or zidovudine) and nevirapine in perinatal HIV infection has shown encouraging results.

SEPTIC UMBILICUS (*Omphalitis*)

Umbilical infection in the newborn is a common problem. The etiologic factors include poor sanitary conditions and local application of unsterile dressings. *E. coli* and *Staphylococcus* are the most common organisms responsible for it.

It may present as: (a) slight purulent discharge from localized infection of the stump, (b) umbilical abscess, (c) periumbilical cellulitis, or (d) umbilical gangrene. Even septicemia and neonatal tetanus may well be regarded as forms of umbilical sepsis. If left untreated or inadequately treated, localized infection may be accompanied by formation of a pinkish, rounded, berry-like mass with granulation tissue (*umbilical granuloma*). It is responsible for persistent serous discharge for several weeks or even months.

Prevention lies in aseptic care of the umbilicus, including its cutting. It is best left uncovered rather than dressed with a binder.

Treatment consists in administering a broad-spectrum antibiotic and local application of tripe-dye, gentyian violet paint or a powder/cream containing bacitracin and neomycin. An umbilical granuloma needs cauterization by touching it with silver nitrate or copper sulfate crystal.

SEPTICEMIA

Septicemia is a serious neonatal problem. Failure to recognize and treat it early is met with high mortality.

Etiopathogenesis

Predisposing factors include febrile maternal illnesses, prolonged rupture of membranes, frank amnionitis, instrumentation and equipment (use of catheters, respirator, resuscitator, feeding bottles, solutions for cold sterilization, incubator, face masks, white aprons, etc), mouth to mouth breathing and umbilical sepsis. Medical personnel, including doctors and nurses, may be responsible for passing on infection to the neonates. Thus, infection may be contracted antenatally, or during or after birth.

The portal of entry in vast majority is the umbilical vein. At times, GIT or some other infection may also cause septicemia.

The common causative pathogens are *E. coli*, *Staphylococcus aureus*, *Pseudomonas aeruginosa* and *Klebsiella pneumoniae*. Any pathogenic organism can lead to this condition, including *Streptococcus hemolyticus*, *Staphylococcus albus*, *Listeria monocytogenese*, *Enterobacter*, *Alkaligenase fecalis*, *Proteus mirabilis*, *Salmonella typhimurium*, *Citrobacter*, *Serratia*, *Bacteroides sp*, *Peptococcus*, *Peptostreptococcus*, *Clostridium perfringens* and *Candida*.

Remember that, like anywhere in the world, in India too the microbiologic pattern of neonatal septicemia varies from time to time and from institute to institute. The neonatal units must, therefore, have an ongoing review of the causative organisms and their antibiotic sensitivity pattern.

Clinical Features

Except when the infant is infected *in utero*, during delivery or immediately after birth, manifestations usually become evident towards the fag-end of the first week or in the second week. These are identical despite varying causative agents and may vary from "inapparent" or "silent" to "fulminant", depending on severity of infection, maturity and birth weight of the infant.

The earliest manifestations may be just lethargy, refusal of feeds, vacant listless look, circumoral cyanosis, vomiting, irritability, restlessness apneic spells, and cyanosis. Loose motions, abdominal distention, fever or hypothermia (latter is more common and more dangerous), failure to gain weight, jaundice, respiratory distress and skin eruptions are other prominent features. Umbilicus is often septic. Hepatosplenomegaly and pallor are present in some cases.

Associated meningitis is frequent. The occurrence of convulsions should arouse suspicion of its existence.

Depending on involvement of various systems, there may be pneumonia, urinary tract infection, sclerema, DIC, shock, necrotizing enterocolitis, etc.

Diagnosis

It is primarily clinical. One should take advantage of the clinical clues for probable etiologic diagnosis (Table 17.14). Of the recommended investigations, the most important are blood culture and swab from septic umbilicus or any other location of superficial infection.

Table 17.14: Clinical clues to etiologic diagnosis

Clues	Organisms
Such superficial infections as pyoderma, abscess, conjunctivitis, umbilical sepsis, osteomyelitis; onset of manifestations after 72 hours of birth	<i>Staphylococcus</i>
Grayish-black gangrenous lesions over skin	<i>Pseudomonas</i>
Peripartum flu-like maternal illness, gastroenteritis, meconium-stained liquor amnii, baby is unwell right at birth with limpness and develops respiratory difficulty, apneic spells, rash and hepatosplenomegaly on the first day	<i>Listeria</i>
Maternal fever during labor, prolonged rupture of membranes (PRM); respiratory distress within 3 hours of birth, apneic spells, shock	<i>Streptococcus</i> group B

For early diagnosis of septicemia, the following screening procedures are available:

1. Direct
 - Blood culture
 - Buffy coat smear examination
2. Indirect
 - White cell count
 - Band cell count
 - Band count/neutrophil ratio
 - Morphologic changes in neutrophils
 - Microerythrocyte sedimentation rate (m-ESR)
 - Gastric aspirate for polymorphs
 - C-reactive protein (CRP)
 - Counter immunoelectrophoresis (CIE)
 - Limulus lysate test
 - NBT test
 - Serum IgM level
 - Alpha hepatoglobins
 - Serum fibrinogens.

Presence of two or more parameters (TLC < 5,000/mm³, band/total neutrophil) count ratio > 0.16, m-ESR > 15 mm, positive CRP) means a *positive sepsis screen*. A repeat screen is indicated in case of a negative result after 12 hours; every 48 hours in ventilated neonates.

Lumbar puncture is of value if meningitis is also suspected. Chest X-ray, blood sugar, urine for routine and culture and serum bilirubin are other useful investigations.

Treatment

Specific chemotherapy In early septicemia, in order to cover most gram-positive and negative pathogens, ampicillin + gentamicin/amikacin is the recommendation. In ampicillin resistance, the choice is a third generation cephalosporin + gentamicin/amikacin. In case of accompanying meningitis, a third generation cephalosporin + ampicillin/amikacin make the ideal therapy.

In late onset septicemia, first-line therapy should be ampicillin + gentamicin/amikacin and the second line cefatoxime + amikacin. If Staph. is suspected, cloxacillin needs to be added. For resistant Staph., coamoxyclov or vancomycin is the best.

In nosocomial septicemia (*Staph*, *Klebsiella*, *Pseudomonas*), ceftazidime/cefepazone + netilmicin make an excellent combination. Nevertheless, vancomycin is the best.

If the culture and sensitivity report warrants a change in the antimicrobial therapy, it should be made.

Minimum duration of chemotherapy for uncomplicated septicemia, urinary tract infection and meningitis or osteomyelitis is 10 to 14 days, 14 days and 3 weeks respectively.

Chemotherapy initiated for presumptive septicemia which fails to be confirmed by blood culture or follow-up observations needs to be discontinued after 5 days.

Supportive measures These include IV drip, oxygen for hypoxia, blood transfusion for anemia and shock as also to boost defense mechanism through opsonins and polymorphs.

Promising new therapeutic modalities include high dose intravenous immunoglobulin (IVIg), exchange transfusion, granulocyte transfusion, fibronectin and cytokines. Available cytokines are:

- Granulocyte colony stimulating factor (G-CSF)
- Granulocyte macrophage colony stimulating factor (GM-CSF)
- Tumor necrosis factor-alpha (TNF-alpha)
- Gamma interferon.

Indications of such a therapy include poor response to appropriate antibiotic therapy with persistent neutropenia, depleted marrow neutrophil storage pool (NSP) or disturbance in myeloid progenitor proliferation.

Its risks are transmission of HIV and cytomegalovirus.

In case of scleroma, endotoxic shock and meningitis, administration of hydrocortisone may be considered.

In DIC, fresh blood transfusion followed by heparin and platelet and fibrinogen therapy is indicated.

Prolonged chemotherapy should be supplemented with vitamin K and other vitamin therapy.

Prognosis

Despite availability of newer broadspectrum chemotherapy, almost 25 to 50% of neonates with septicemia die. Mortality is higher in:

- early-onset (within 72 hours of birth) septicemia
- the presence of serious congenital anomalies.
- the presence of meningeal involvement
- gram-negative septicemia
- *pseudomonas* infection where it is worst
- LBW and premature babies.

CONJUNCTIVITIS

Neonatal conjunctivitis may (Fig.17.40) be caused by such agent as *Chlamydia trachomatis*, *N. gonococcus*, and *Staphylococcus aureus*. Uncommon causative agents include *Streptococcus* (group A and B), *Pseudomonas aeruginosa*, and herpes virus hominis type 2. Use of silver nitrate drops may also cause conjunctival inflammation which manifests within 6 to 12 hours after birth and disappears by 24 to 48 hours.



Fig. 17.40: Neonatal conjunctivitis, showing edema of the eyelids with chemosis. Delay in instituting proper treatment may lead to involvement of the deeper layers of conjunctiva as also cornea

Simple sticky eyes with no purulent discharge, a common observation during the first couple of days, needs only saline irrigation or sulfacetamide drops (10%).

Purulent conjunctivitis due to gram-positive cocci needs to be treated with penicillin (2,500 units/ml), framycetin or chloramphenicol eye drops.

Gonococcal ophthalmia is treated with (it is responsible for profuse purulent discharge), systemic penicillin therapy (100,000 to 150,000 units/ kg/day in 2 or 3 divided doses) and penicillin, gentamicin or chloramphenicol eye drops. A single dose of kanamycin (75 to 150 mg IM), is also effective. Currently, the treatment of choice is ceftriaxone, 25 to 50 mg/kg/day for 7 days.

Conjunctivitis caused by *Chlamydia trichomatis* (inclusion blenorrhea) needs treatment with 10% sulfacetamide eye drops. In case of poor response, oral erythro-mycin should be given.

PYODERMA

Superficial skin eruptions, usually caused by *Staphylococcus aureus* and albus, result from contaminated hands of the personnel responsible for caring the neonate. No treatment other than local application of triple-dye is indicated.

Pyoderma, manifesting as pustules over scalp, neck, axillae and groins, may spread to cause abscesses, osteomyelitis, parotitis, septicemia and, what is worst, remarkable erythema, bullae and exfoliation (*pemphigus neonatorum*).

Treatment of these lesions is puncturing followed by application of triple dye. Any suggestion of spread of infection is an indication for administering erythromycin or some such antibiotic agent.

ORAL THRUSH (Moniliasis, Candidiasis)

This condition, caused by *Candida albicans*, may occur even in healthy neonates from the infected birth passage during delivery, infected feeding equipment and prolonged antibiotic therapy.

The lesions, usually preceded by redness of oral mucosa and tongue, are characteristically discrete whitish patches/spots over the tongue mucosa, gums and lips; extension over to the posterior oropharynx may occur, leading to swallowing difficulties. Involvement of the perianal region is frequent, so is

the monilial diarrhea. The lesions are difficult to be removed by scraping.

Response to local application of gentian violet (0.5%), nystatin (2,00,000 units/5 ml), or cotrimazole, after each feed, is gratifying. A 5 to 7 days course suffices.

NOMA NEONATORUM

Occasionally, *Pseudomonas aeruginosa* infection may cause superficial gangrenous lesions involving nose, lips, mouth, anus, eyelids and scrotum. The condition proves fatal within a few days.

NEONATAL MALARIA

On account of the protection provided by the trans-placental passage of maternal IgG antibodies which may act as opsonizing agents or block the merozoitic invasion of erythrocytes so that the erythrocytic (hepatic) phase is absent, neonatal malaria is infrequent in highly malarious areas.

Etiology

Neonatal malaria is of three types:

1. *Congenital*: It is due to transplacental transmission of the malarial parasite and is rare since placenta, as a rule, is supposed to act as a barrier to such a transfer. In a span of over two decades, we could diagnose it in only 50 instances though we have all along been actively looking for it.
2. *Transfusion malaria*: It follows infected blood transfusion.
3. *Naturally-acquired malaria*: It results following an actual bite of a previously infected female Anopheles mosquito.

Clinical Features

Clinical manifestation include unexplained pyrexia with hepatosplenomegaly, anemia, slight jaundice, poor feeding, irritability and jitteriness. Intrauterine growth retardation may be seen in congenital malaria, especially if the baby is first born and was affected early in intrauterine life.

Diagnosis

The points favoring diagnosis of congenital malaria are:

- Malaria in the mother during pregnancy
- Manifestations occurring before the minimal incubation period (12 to 16 days for *P vivax* and *P ovale*, 10 to 13 days for *P falciparum* and 27 to 37 days for *P malariae*).
- Absence of history of blood transfusion.

Treatment

Chloroquin, 10 mg/kg (0) or 5 mg/kg (IM), should be given after taking blood for peripheral film. The same (half dose) may be repeated after 6 hours, 24 hours and 48 hours.

Supportive treatment directed at controlling fever, raising hemoglobin level and maintaining water and electrolyte balance and nutrition is also warranted.

Prophylaxis

- Timely treatment of maternal malaria and even empirical administration of chloroquin to pregnant mothers during the third trimester.
- Blood for transfusion must be tested for malarial parasite.
- Standard measures for control and eradication of malaria.

TETANUS NEONATORUM

A detailed account about tetanus has already been given in Chapter 19.

Neonatal tetanus follows contamination of the umbilical stump following cutting of the cord with an infected blade, knife or scissors, or application of cowdung, etc. on it—a common practice with untrained traditional birth attendants (TBAs).

Manifestations usually occur between 2 days to 2 weeks of age. To start with, the baby has unexplained crying, refusal of feeds and apathy. On forcing the feed, reflex spasm of masseters, pharyngeal muscles leads to trismus (lock jaw) (Fig. 17.41), dysphagia and choking. Spasms of limbs and generalized rigidity (Fig. 17.42) with opithotonos in extension follow. Reflex laryngeal spasm may cause apnea and that of respiratory muscles the cyanosis. Continued spasm may lead to pyrexia, tachypnea, tachycardia, dehydration and acidosis. Superimposed infections are common.

Immediately on diagnosis, IV drip must be started not only for providing adequate fluid, electrolyte and



Fig. 17.41: Neonatal tetanus. Note the gross trismus, leading to feeding difficulties



Fig. 17.42: Neonatal tetanus

nutritional intake but also for administration of drugs. The infant must be isolated in a quiet room with good nursing care and minimum of disturbance. Periodic suction of secretions and maintenance of temperature are important.

ATS (IV) in a single dose or tetanus immunoglobulin (TIG) form the lifeline of the specific treatment. It neutralizes the circulating toxin.

Muscle spasms need to be controlled with diazepam 0.5 to 2 mg/kg/dose and chlorpromazine 2 to 3 mg/kg/dose or paraldehyde 0.15 ml/ kg/dose.

Administer each drug alternately, ensuring that the child receives sedation every 1 to 2 hours.

Antibiotic cover with penicillin and gentamicin is strongly recommended.

Tracheostomy, oxygen, tube feeding, CPPR and assisted ventilation may improve the prognosis considerably.

Overall mortality is about 50 to 75%. Preventive measures include:

- Active immunization of the mother during pregnancy, and
- Education of the traditional birth attendants to use sterilized instrument for cutting the cord.

HEMORRHAGIC DISEASE OF THE NEWBORN

This entity is discussed in Chapter 27 (Pediatric Hematology).

NEONATAL JAUNDICE

Jaundice is a common manifestation among newborns. Unlike adults in whom it is clinically detectable with a serum bilirubin of >2 mg/dl, in neonates it is apparent only when serum bilirubin is >5 mg/dl. Approximately, it is encountered in about 75% of them with a relatively higher incidence in preterm neonates.

Etiologic Considerations

A. Classification Based on Time of Onset

Table 17.15 lists the important causes of jaundice in accordance with the time of its appearance.

B. Classification Based on Conjugation of Bilirubin

Conjugate hyperbilirubinemia which is usually secondary to hypertrophic biliary atresia or neonatal hepatitis in newborns has already been discussed in details in Chapter 25 (Pediatric Hepatology). Table 17.16 gives etiology of unconjugated hyperbilirubinemia.

Frequently Encountered Types of Jaundice

Physiologic Jaundice (Fig. 17.43)

Most of the neonates (50-60 % full-term, 70-80% preterm) develop it on account of:

- increased production of bilirubin (outcome of low lifespan of fetal RBC and very high hemoglobin level in the neonate)

Table 17.15: Important causes of neonatal jaundice based on age of onset

First Day

- Rh and ABO incompatibilities (hemolytic disease of the newborn)
- Intrauterine infections like toxoplasmosis and cytomegalic inclusion disease
- G-6-PD deficiency
- Hereditary spherocytosis
- Drug administration to mother (vitamin K, sulfisoxazole, salicylates)
- Homozygous alpha-thalassemia

Second and Third Days

- Physiologic
- Hyperbilirubinemia of newborn
- Birth asphyxia
- Cephalhematoma
- Acidosis
- Hypothermia
- Hypoglycemia
- Drugs
- Familial nonhemolytic icterus as in Crigler-Najjar disease, Gilbert disease, Dubin-Johnson syndrome

Fourth to Seventh Days

- Septicemia
- Syphilis
- Toxoplasmosis
- Cytomegalic inclusion disease
- Extrahepatic atresia of bile duct
- Breast-milk jaundice

After First Week

- Septicemia
- Extrahepatic atresia of bile duct
- Hereditary spherocytosis
- Neonatal hepatitis
- Drug-induced hemolytic anemia
- Galactosemia

Persistent Jaundice during First Month

- Inspissated bile syndrome
- Cretinism
- Congenital hypertrophic pyloric stenosis

- decreased hepatic uptake of bilirubin from plasma,
- defective bilirubin conjugation,
- defective bilirubin excretion and
- increased enterohepatic circulation.

Physiologic jaundice is a self-limiting condition. In term infants, it appears on second or third day (between 30-72 hours) and reaches peak on 4th or 5th day. It is generally mild, the serum bilirubin seldom exceeding 12-15 mg%. It disappears by 10th day.

Table 17.16: Causes of unconjugated hyperbilirubinemia

Physiologic**Pathologic***Increased Production of Bilirubin*

- *Hemolytic disease of the newborn*: Rh isoimmunization, ABO incompatibility, minor blood group incompatibility
- Hereditary spherocytosis
- *Nonspherocytic hemolytic anemia*: G-6-PD deficiency, pyruvate kinase deficiency, alpha-thalassemia
- *Acquired hemolysis disorders*: Vitamin K₃-induced hemolysis, microangiopathies
- Septicemia
- *Increased enterhepatic circulation*: Intestinal obstruction, congenital hypertrophic pyloric stenosis, meconium ileus paralytic ileus, Hirschsprung disease

Decreased Clearance of Bilirubin

- *Inborn errors of metabolism*: Familial nonhemolytic jaundice (Crigler-Najjar syndrome) type I and II, Gilbert disease
- *Medications*: Vitamin K₃
- *Hormones*: Breastmilk jaundice, hypothyroidism, hypopituitarism

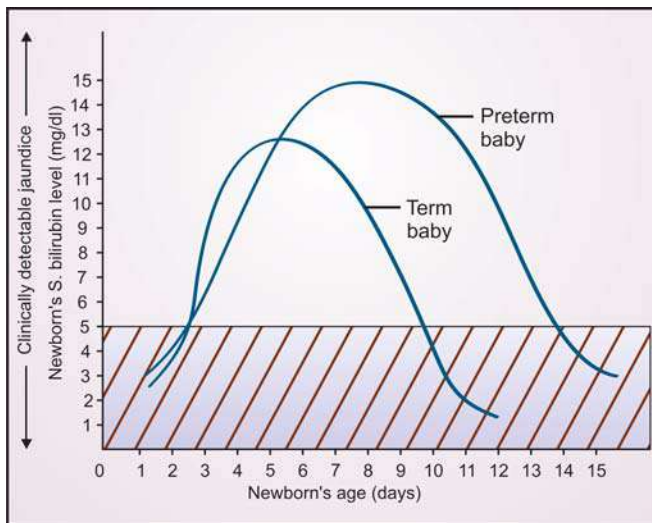

Fig. 17.43: Physiological jaundice: Time table in term and preterm neonates. Note that onset of jaundice is about the same time in both, i.e. after 24 hours of birth. Serum bilirubin level at which jaundice becomes clinically detectable is 5 mg/dl

In case of the preterm baby, physiologic jaundice may appear little earlier (but always after 24 hours), may be relatively deeper (up to 15 mg/dl), and reaches peak on 6th or 7th day. It disappears by 14th day.

Physiologic jaundice is a benign condition, needing no treatment, except in preterm infants in whom phototherapy and exchange transfusion may be needed to safeguard against kernicterus. Nevertheless, the infant needs to be closely followed up for undue

rise or persistence of hyperbilirubinemia. In the later situation, he should be investigated for pathologic jaundice.

In certain situations, (IDM, IVH, cephalhematoma, hypothyroidism, inhibitors in breast-milk, hypoxia, CHD, delayed passage of meconium, congenital infections, polycythemia), physiologic jaundice may be exaggerated and/or prolonged beyond the usual limits. This is termed *exaggerated physiologic jaundice*.

Pathologic Jaundice (Unconjugated Hyperbilirubinemia)

The neonatal jaundice not conforming to time table or serum bilirubin level typical of physiologic jaundice is termed “pathologic”. Immaturity, blood group incompatibilities, intrauterine and postnatal infections, G-6-PD deficiency, congenital hypothyroidism, breastmilk jaundice, cephalhematoma and drugs are common causes of pathologic jaundice in India,

Breastfeeding Jaundice

Exclusively breastfed neonates have a tendency to develop higher serum bilirubin levels during first few days of life. The cause may be insufficient lactation leading to inadequate feeding, dehydration and hemoconcentration. It needs no intervention.

Breastmilk Jaundice

A small proportion of exclusively breastfed infants also tend to develop persistence of physiologic jaundice or exaggerated jaundice (serum bilirubin touching 18-20 mg/dl in some) in the second week of life as a result of such substances as 3 alpha, 20 beta pregnanandiol and free fatty acids in mother's milk which inhibit conjugation of bilirubin. It resolves on its own. Occasionally, undue anxiety in the parents may warrant temporary withdrawal of breastfeeding just for 2-3 days.

An Evidence-based Diagnostic Approach

History

The following points should be particularly noted:

- Maternal and family history with special reference to maternal infections during pregnancy, drugs given during pregnancy or labor, previous sibling(s) affected by jaundice or anemia, diabetes, previous blood transfusions

- Ethnic group of the parents and ancestors; h/o consanguinity for hemoglobinopathies
- Delayed passage of meconium
- Time of onset of jaundice
- Whether jaundice decreasing or increasing in intensity
- General condition of the infant: whether healthy, having no feeding difficulty, no fever, no rash?
- Type of feeding: whether breastfed?

Clinical Examination

- Gestational age, activity and general condition of the infant
- Whether umbilicus is septic?
- Whether any evidence of hemorrhage, petechiae, etc.?
- Any congenital malformation?
- Any neurologic finding?
- Size of liver and spleen
- Pallor
- Cephalhematoma
- Hepatosplenomegaly
- Color of urine and stool.
- Clinical detection and grading of severity of jaundice (Box 17.12).

Laboratory Investigations

- Serum bilirubin, both direct and indirect
- ABO and Rh blood grouping of mother as well as baby
- Hemoglobin/ peripheral smear
- Reticulocyte count
- Coombs test of mother as well as baby
- Blood culture
- Liver function tests
- G-6-PD enzyme studies.

Principles of Management

Phototherapy and exchange transfusion are the two major effective therapeutic modalities available today. Additional options include pharmacotherapy in the form of phenobarbital, agar-agar, albumin infusion, n-mesoporphyrin, charcoal, etc.

Phototherapy

First introduced by Cramer, phototherapy has emerged as the most widely used tool for treating unconjugated pathologic hyperbilirubinemia.

Box 17.12: Clinical methods of detection of neonatal jaundice

- **Blanching** Blanching the skin of tip of nose, sternum, abdomen, palms and soles with digital pressure.
In accordance with the Cramer's guidelines based on the observation that neonatal jaundice progresses in a cephalocaudal direction, a rough estimate of the bilirubin level can be made as follows: Face 5 mg/dl, chest and upper abdomen 10 mg/dl, lower abdomen, thighs and upper arm 12 mg/dl, legs and forearm 15 mg/dl, palms and soles > 15 mg/dl (Fig. 17. 44)
- **Icterometer** This is a noninvasive method which is more accurate and less subjective. The tool used is a transparent plastic with 5 graded yellow stripes of different shades corresponding to the serum bilirubin levels. It is pressed against the tip of the nose (in case of very dark skin, gums make a better option). The color of the skin is matched with the yellow stripes to obtain the bilirubin level.
- **Transcutaneous bilirubinometer** This more accurate and more objective but expensive instrument measures the total serum bilirubin employing a photoprobe. The photoprobe is pressed against the skin of forehead or sternum (in case of very dark skin, a drop of blood on a filter paper make a better option). Following analysis by the computerized spectrophotometer, digital display of the bilirubin level is immediately made.

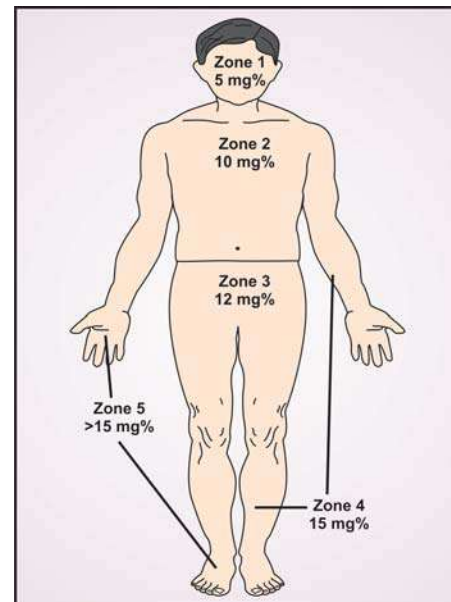

Fig. 17.44: Dermal zones as an index of magnitude of neonatal jaundice (level of serum bilirubin)

Indications

These are listed in Table 17.17.

Table 17.17: Indications of phototherapy

Birth weight	Serum bilirubin at which phototherapy is indicated
2500 g	15 mg/dl
2000-2500 g	12 mg/dl
1500-2000 g	10 mg/dl
1000-1500 g	7 mg/dl
< 1000 g	5 mg/dl

Mode of Action

The value of phototherapy in lowering unconjugated hyperbilirubinemia is widely accepted.

In order to understand its mode of action, it should be remembered that bilirubin absorbs light maximally at 450 to 476 nm. With light sources of this range, most of it (80%) undergoes photoisomerization to bilirubin (of better soluble form). A small portion gets oxidized to biliverdin. These are excreted in bile and to a lesser extent in urine.

That bilirubin is broken down in the skin is now well-documented. A common observation during photo-therapy is the bleaching of the exposed areas. The areas of skin that remain covered continue to have yellow touch.

Whether liver also plays significant role during photoexposure is being currently investigated.

Technique It is now generally opined that blue light is superior to white light. Though simple sunlight is useful, artificial light sources are far better. Most neonatal units employ standard length tube lights (STL) phototherapy. Alternatively, compact fluorescent lamp (CFL) phototherapy units, now available in India, may be employed. These lamps can be mounted with reflectors in frames. It is claimed that these are superior to conventional (STL) units on account of smaller size, focused area, lower scatter and higher irradiance. The advantages include greater efficacy and more acceptability to nursing staff.

Such a phototherapy unit delivers about 200 foot candles of light to the infant. It can also be placed over an incubator.

The only problem with blue light is that it interferes with reasonable observations of the baby. Alternatively, white day-light lamps/tubes are reasonably effective and may be employed. A unit with a combination of both blue and white light tubes may also be employed.

Length of Phototherapy

Just 24 to 48 hours exposure is generally long enough to bring down serum bilirubin level to safe limit. Though many authorities insist on giving continuous therapy, there is evidence to the effect that intermittent exposure is almost equally good.

Skin color is not a reliable criteria for stopping or con-tinuing phototherapy. The yellow color of the skin dis-appears or regresses much earlier than the return of serum bilirubin to near normal. It is, therefore, desirable that serum bilirubin estimation is done at intervals of 12 hours. Termination of phototherapy is indicated at serum bilirubin < 11 g /dl on 2 consecutive sittings 24 hours apart.

Special Precaution

During exposure to phototherapy, infant's eyes should always be protected with something like a mask (Fig. 17.45). This is essential if chances of retinal damage are to be nullified. In case of the male neonate, the external genitalia too need to be covered to prevent gonadal insult.

Contraindication

Congenital erythropoietic porphyria.



Fig. 17.45: Neonatal jaundice. Note the yellow discoloration of the skin. ABO incompatibility was responsible for elevation of the serum bilirubin to 16 mg% by third day in this full-term neonate. Response to phototherapy was excellent

Side Effects

A. Immediate

- Loose motions (greenish or dark-brown), are due to high content of photodegeneration products
- Dehydration, generally mild, occurs in some cases
- Fever (hyperthermia) or hypothermia
- Hypocalcemia
- Skin rashes are usually mild and self-limiting, disappearing rapidly
- Bronzing of skin, urine and serum (*bronze baby syndrome*) which may occur in conjugated hyperbilirubinemia. It disappears soon after cessation of phototherapy with no permanent sequelae
- Electric shock.

B. Delayed

- Retinal damage and possible retardation of brain growth
- Late anemia and hemolysis
- Skin malignancy
- Delayed puberty because of long-term adverse effects on endocrines and sexual maturation.

C. Nursing Staff

- Headache and giddiness

Fiberoptic Phototherapy (Bili Blankets)

An alternative phototherapy is what is termed fiberoptic phototherapy. This relatively new technique employs light from a fiberoptic source which is fanned out on a cummerbund wrapped round the neonates torso. Eye padding/shielding (covering) is not needed. Unlike the conventional photo-therapy in which irradiance is maximal at the body surface nearest to the light source, irradiant energy in this technique is uniformly distributed. Further, it is simple causing no side effects. It is as effective as the conventional phototherapy. Since it is small, light weight and portable unit, it can be used at home too. The mother can pick up the baby without discontinuing phototherapy. It, therefore, does not interfere with mother-baby bonding.

Exchange Blood Transfusion

Aims and Objectives

It is by far the best method to:

- Remove excess bilirubin and other harmful substances (say, Rh positive cells which have become

noxious to baby from blood) and to replace the blood by healthy donor blood.

- Correct severe anemia by replacing blood of low packed cell volume (PCV) by that of normal PCV. Thus, overloading of the circulation as also congestive cardiac failure are avoided.

Indications

- Any nonobstructive jaundice with serum bilirubin level of 20 mg/dl or more in full-term and 15 mg/dl in preterm infants.
- Kernicterus irrespective of serum bilirubin level.
- Hemolytic disease of the newborn under the following situations:
 - a. All above, plus
 - b. Cord hemoglobin 10% or less
 - c. Cord bilirubin 5 mg/dl or more
 - d. Rise of serum bilirubin of more than 1mg/dl/hour. Thus, a level of 12 mg/dl within 24 hours and 15 mg/dl% within 48 hours are indications for an exchange
 - e. Maternal antibody titer of 1: 64 or more, positive direct Coombs test and previous history of a severely affected baby.

Some workers consider congestive cardiac failure, reticulocyte count of 6% or more, normoblast count of 10% or more, serum bilirubin/protein ratio above 3.5 and salicylate saturation index of more than 7 as additional indications for an exchange.

Choice of donor blood The donor blood should be fresh (less than 3 days old). The amount needed for an adequate exchange is about 160 ml/kg (double the blood volume). For the usual type of Rh hemolytic disease. Rh negative blood of appropriate ABO group is used. It should be crossmatched against mother's blood. Also, it should be made sure that the blood is slowly warmed to infant's temperature.

If citrated or heparinized donor blood is used, one should be prepared for hypocalcemia, hypoglycemia, hyperkalemia and metabolic acidosis. Further, citrated blood leaves the infant with a relatively low hemoglobin. As a precaution, some authorities like to give injections of calcium gluconate at regular interval when using citrated blood for exchange.

Technique (Fig. 17.46)

Environment The procedure should be performed in the operation theatre, the nursery or intensive-care room. Two doctors should be present; at least one

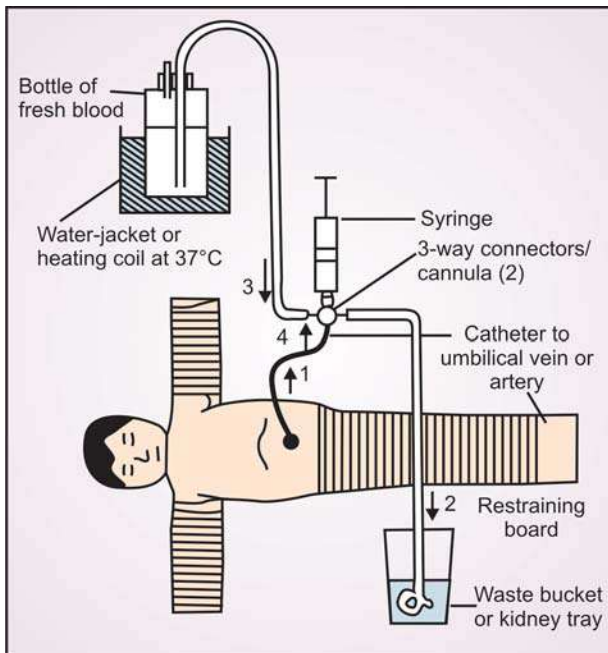

Fig. 17.46: Exchange blood transfusion technique: Note the salient features. First 10 ml blood is drawn from the infant (1) which is discarded into a waste bucket or kidney tray, (2). Then, 10 ml blood is drawn from the bottle of blood, (3) which is injected into the infant (4). By repeating the procedure, 180 ml/kg of blood is exchanged

Note: In certain situations, instead of umbilical vessel, a peripheral vein may be employed for exchange

should be able to intubate and resuscitate the baby if the need be. The assistant should be entrusted with the monitoring work like watching the condition of the baby and recording the time and the amounts of blood removed and transfused.

The whole procedure should be conducted with all the aseptic precautions.

Room temperature It should be around 27°C. If that is not workable, the procedure may be carried out in an incubator maintaining the temperature at 27 to 30°C.

Feeds Four hours before the procedure, no feed-in fact, nothing by mouth-should be given. The stomach should be aspirated before the exchange to minimize the risks of vomiting and aspiration into the lungs.

Premedication Vitamin K₁ should be given in the dose of 1 mg intramuscularly, before initiating transfusion.

Some centers advocate that, 1 to 12 hours before actual exchange, 25% solution of salt poor albumin in the dose of 1 g/kg should be given. This is claimed to assist in getting rid of the bilirubin. When congestive

cardiac failure is present, such a procedure may further overload the circulation and is best if not done.

Immobilization Some degree of immobilization is essential, especially for inserting the umbilical catheter. A restraining board is of value in this behalf.

Heparinized saline It is made by mixing 2 ml of heparine (1,000 units/ml strength) to 250 ml of saline. It should be available in a bowl. Before beginning the exchange, the whole apparatus should be washed with this saline. It is also to be used if the syringe becomes sticky.

Catheterization Umbilical cord is cut less than 2.5 cm from the skin surface. The vein can be located as a flattened thin-walled structure containing a small amount of blood which should be gently removed. Having attached loosely a ligature round the base of the cord, insert the umbilical catheter into the vein. The catheter should be filled with a flushing solution, or donor blood before insertion. This precaution minimizes the risk of air embolism.

When free flow of blood is obtained, ligature is tightened.

The catheter should be deep enough to reach the inferior vena cava.

Some workers prefer to cannulate the umbilical artery rather than the vein. It is pushed into the artery until it reaches the aorta at the level of the diaphragm.

An alternative method of exchange transfusion using a peripheral vessel rather than umbilical vessel may be employed in the following situations:

1. Partial transfusion in sick neonates.
2. Premature sick neonates at risk of developing necrotizing enterocolitis.
3. Presence of omphalitis hampering use of umbilical catheterization.
4. Difficulty in inserting a catheter of minimal size into the umbilical vein through the ordinary route.

Exchanging the blood Ten ml of infant's blood is withdrawn with gentle suction followed by replacement with an equal amount of fresh donor blood. The procedure is repeated until 180 ml of blood/kg of body weight has been exchanged. This is called *two volume exchange*, i.e. twice the blood volume of 85-90 ml/kg.

The total time taken for the exchange varies between 45 to 90 minutes.

Removing the catheter The catheter should never be left in the vein/artery after the exchange. After its removal, the umbilical stump should be dressed with

sterile saline. The moist stump is of value for repeat exchanges.

Postexchange period For about 3 hours after the exchange, oral feeds should not be given. In the incubator, infant's head should be slightly raised.

What about prophylactic antibiotics? Most authorities feel there is no place for routine antibiotics unless sepsis is suspected.

An important issue is as to who should get a repeat exchange transfer. Generally, the candidate is a preterm baby, especially the one who received intrauterine transfusion.

There is another situation too. Most infants show some rise in serum bilirubin 3 to 4 hours after exchange. This is, as a rule, transitory. In an occasional infant, the level may continue to rise after the postexchange fall. It may touch the level warranting another exchange (Table 17.18).

Exchange by Alternative Routes

Indications of such an exchange have already been mentioned.

Attempt should be made to use the umbilical vein above the umbilicus. This will need a *cut-open* either by a vertical incision at 12 O'clock position or by a crescentic incision in the skin about 1 cm above the umbilical ring.

The umbilical vein cut-open may, however, fail. The best alternative in such a situation would be to use the saphenous vein.

The saphenous vein may be good enough for introducing donor blood. At times, withdrawal of blood is, however, a real problem. For the latter purpose, the radial artery may be used.

Experience has shown that thrombosis of the femoral vein often follows when saphenous vein is employed for exchange. This, however, is a transitory phenomenon. No after-effects have so far been reported.

Table 17.18: Guidelines for distance for introduction of catheter into the umbilical vein

Infant's length (cm)	Catheter distance (cm)
40	7
45	8
50	9
55	10

Note: Approximately, catheter should be 1/5th to 1/6th of the infant's length

Warning Signs during Exchange

These include vomiting and crying, grunting respiration and cyanosis, CCF, sudden cardiac arrest, hypothermia, hyperkalemia, hypocalcemia, acidosis, thromboembolism, arrhythmias, seizures and bleeding.

Delayed Complications

While considering the late problems that may arise from exchange transfusion, the following points should be particularly noted:

- *Anemia* of some degree is almost always seen in babies who receive exchange for hemolytic disease. The hemoglobin should, therefore be estimated every week during the first month and then every fort-nightly. The hemoglobin of less than 7 g % during first 2 or 3 weeks may be an indication for a small "top-up" transfusion. Iron and folic acid may be indicated if the hemoglobin fails to rise by the age of 6 weeks.
- *Sepsis* which manifests about 12 to 24 hours after exchange. Fever, profuse sweating, feeding difficulty, skin rash, progressive pallor and even hepatosplenomegaly may be seen.
- *Portal thrombosis*, generally due to sepsis (at times undetected), may manifest as progressive increase in the size of spleen and bleeding from anastomotic sites.
- *Intestinal perforation* may manifest in the form of rectal bleeding, refusal to feed, bile-stained vomitus, and abdominal distention. After confirming the diagnosis by X-ray studies, a laparotomy is immediately required.

Pharmacotherapy and Other Therapies

Phenobarbital Administering phenobarbital, 30 to 120 mg/day to mothers a few weeks prior to delivery or 5-8 mg/ kg/day to the newborn, enhances the activity of the enzyme, *glucuronyl transferase*. The baby is thus, better prepared to deal with the load of bilirubin liberated after birth.

The role of phenobarbital is, therefore, more or less prophylactic. There is no point in giving phenobarbital to an infant who is already jaundiced (it will take 3-7 days and even more in preterms to demonstrate its usefulness and also cause such side effects as drowsiness, lethargy and poor feeding), except in

Crigler-Najjar syndrome type II and inspissated bile with conjugated hyperbilirubinemia in which it may help by enhancing canalicular bile flow.

Metalloporphyrins In selected full-term neonates with severe hyperbilirubinemia, a single dose of Sn-mesoporphyrin may control the hyperbilirubinemia and eliminate need for phototherapy. The beneficial effect is supposed to be related to inhibition of the activity of heme oxygenase and reduction in the bilirubin production.

Other agents Bilirubin binding agents in the gut like agar and charcoal as also IV albumin infusion as such are of doubtful clinical value in effectively treating pathologic hyperbilirubinemia. Frequent breastfeeding cuts down enterhepatic circulation by resorption of unconjugated bilirubin from the gut.

NEONATAL CHOLESTASIS SYNDROME

The term, *cholestasis* (*chole* meaning bile, *stasis* meaning stoppage), denotes decrease or absence of bile flow into the duodenum so that there is a retention in blood of all the substances that are normally excreted in the bile. It may result from (a) failure of hepatocytes to secrete bile, (b) obstruction/disappearance of intrahepatic bile duct, or (c) obstruction of extrahepatic bile duct. The term, *neonatal cholestasis syndrome*, should be restricted to conjugated hyperbilirubinemia persisting beyond a fortnight. The two most important causes are neonatal hepatitis syndrome (discussed later in this very chapter) and extrahepatic biliary atresia (Chapter 40: Pediatric Surgery). The topic is discussed in details in Chapter 25 (Pediatric Hepatology).

G-6-PD Deficiency

The enzyme *glucose-6-phosphate-dehydrogenase* is essential for maintaining the stability of the red cell membrane. Recent times have seen increasing recognition of its genetic deficiency in various ethnic groups. This etiologic factor has, as a result, emerged as a leading cause of pathologic jaundice in the neonatal period, especially among the Mediterranean, African, Chinese and Indian stock.

It is inherited as a X-linked recessive disease. Males suffer more than females though female carriers may also manifest mild disease. For details, see Chapter 27.

NEONATAL HEPATITIS SYNDROME

Neonatal hepatitis, or the so-called *giant-cell hepatitis*, may manifest any time during the first six weeks of life. Males show higher incidence. Familial and higher occurrence in siblings has also been recorded.

Etiopathogenesis

A variety of viruses, including the Australia antigen, have been incriminated.* There is evidence that the virus crosses the placenta.

Multinucleated giant cells with complete loss of normal pattern of hepatic lobules and increased fibrous tissue around necrotic liver cells as also in the portal tracts are the characteristic histologic findings. Extrahepatic bile ducts are normal.

Clinical Features

The onset is usually insidious with marked jaundice (obstructive), grossly enlarged liver (surface is smooth but consistency firm) and moderate splenomegaly (Fig. 17.47).



Fig. 17.47: Neonatal hepatitis

* Giant-cell hepatitis has also been described in nonviral diseases, e.g. galactosemia, alpha-1-antitrypsin deficiency, cystic fibrosis, Rotor syndrome, syphilis, toxoplasmosis, septicemia, etc.

Table 17.19: Neonatal hepatitis vs biliary atresia

Features	Neonatal hepatitis	Biliary atresia
Sex	Predominantly in males	Predominantly in females
Onset	Any time during first 6 weeks of life	Around 7th day
Jaundice	Peak → moderate → mild	Mild → moderate → peak
Activity	Normal or slow	Normal
Hepatosplenomegaly	Early	Late
Liver function tests	Grossly abnormal (except alkaline phosphatase)	Slightly abnormal (except alkaline phosphatase)
Rose-Bengal test (excretion in stools)	< 15%	< 10%
Biopsy	Giant cells	Dilatation and hyperplasia of bile canaliculi
Cholangiogram	Normal	Reveals block
Australia antigen	May be present	Absent

Child shows poor weight gain. Vomiting is common. Activity may be normal or slow.

Stools are light but not typically clay-colored. Urine is high colored.

Diagnosis

Liver function tests are grossly abnormal.

Liver biopsy is a “must” for exact diagnosis. At times, operative biopsy may have to be resorted to. Differential diagnosis is mainly from extrahepatic biliary atresia (Table 17.19).

Treatment

Supportive therapy is the mainstay of treatment. Steroids are of doubtful value.

Prognosis

At least 25% cases of neonatal hepatitis die. Among the survivors, incidence of postnecrotic cirrhosis and portal hypertension in later years is fairly high.

HEMOLYTIC DISEASE OF THE NEWBORN

This disease is caused by incompatibility between mother’s blood group and that of the baby. Crossing over of the red cells of the fetus produces antibodies in the mother. Nothing happens to the mother. But, when these antibodies cross the placenta and enter baby’s circulation, they cause hemolysis. The resultant anemia, jaundice and other manifestations vary with the intensity of hemolysis.

Two types of incompatibilities have been described: (i) Rh incompatibility and (ii) ABO incompatibility.

RHESUS HEMOLYTIC DISEASE (Rh Isoimmunization)

About, 1 in 5 mothers with Rh negative blood group have trouble with their babies. The problem arises when the mother is carrying Rh positive baby. Among the Rh factors, D is the one almost always involved.* The first baby is rarely affected.**

Clinical Features

Clinically, Rh hemolytic disease may manifest as hydrops fetalis, icterus gravis or hemolytic anemia.

Hydrops fetalis This is the severest form of the disease. The infant is often preterm and may die *in utero* or shortly after birth from severe anemia and CCF. He is markedly edematous with effusion in serous cavities (Fig. 17.48) and has gross hepatosplenomegaly. In case of stillbirth, the fetus may be macerated. Placenta is always large and edematous.

Icterus gravis When hemolysis *in utero* is less intense, deep jaundice appears during the first 12 to 24 hours. Progressive anemia and hepatosplenomegaly are invariably present. Some may have purpura. Incidence of *kernicterus* is high. Those who manage to survive are often left with sequelae.

* The various Rh factors are c, d, e, C, D and E.

** The first baby may be affected if the mother had an abortion or blood transfusion with Rh positive blood.

Conditions in which a Rh negative mother may give birth to neonates without icterus are:

- When father too is Rh negative
- When father is heterozygous Rh positive in which case there is 25% chance of a Rh negative neonate.
- When ABO incompatibility accompanies Rh incompatibility
- When mother is nonreactor in which case she is unable to respond by producing antibodies.



Fig. 17.48: Hydrops fetalis

Congenital hemolytic anemia This is the mildest but also the rarest form of Rh hemolytic disease. Jaundice is generally absent. Anemia and hepatosplenomegaly are often detected towards the end of the first week or later.

Diagnosis

The diagnosis has got to be made in the fetus or immediately after birth if serious consequences of the disease are to be prevented.

The foremost investigation is to demonstrate that the mother is Rh negative whereas the infant is Rh positive. Occasionally, a Rh positive infant may type as Rh negative because of the “blocking antibodies”. If possible, father’s Rh group should also be tested.

Direct Coombs test on infant’s red cells is positive. Anti-Rh titer of mother is high.

Other investigations show high serum bilirubin (indirect or unconjugated), reticulo-cytosis, anemia, anti-Rh agglutinins and hypoglycemia.

For diagnosis of the fetus at serious risk, *amniocentesis* may be performed by abdominal puncture and a small amount of fluid obtained for spectrophotometric analysis. An elevated peak at 450 milli M after 24 weeks of gestation is an indication for intrauterine transfusion.

Treatment

Surgical induction of labor during 38th week should be done when hemolytic disease is anticipated from high titer of Rh antibodies.

After birth, specific treatment consists in giving exchange transfusion, using group “O” Rh negative blood. Exchange transfusion prevents CCF and kernicterus. It has reduced the death rate to mere 3% in infants who are born alive.

Digitalization for CCF, thoracentesis and paracentesis for massive fluid in serous cavities and diuretics are some of the other measures of value.

Prevention

Every Rh negative mother who has given birth to a Rh positive baby should be given one ml of anti-D immunoglobulin intramuscularly within 72 hours of delivery. It is also indicated when:

1. Rh positive blood is accidentally transfused to a Rh negative mother, and
2. Rh negative mother who had an abortion. This destroys or coats the Rh positive cells that have managed to enter the mother’s blood and thus prevents formation of antibodies. The results of these injections are exceedingly rewarding as far as prevention of isoimmunization is concerned.

ABO-HEMOLYTIC DISEASE

Unlike *Rh hemolytic disease*, it is generally mild. In this case, mother’s group is “O” and infant’s A or B. Likewise, she develops anti-A or anti-B antibodies in her blood. First borns are more likely to have this disease.

Clinical features may include jaundice, anemia and hepatosplenomegaly. Jaundice is frequently delayed until 48 to 72 hours. Peripheral blood film shows microspherocytosis.

No treatment is needed in majority of the cases. If serum bilirubin exceeds 20 mg%, exchange transfusion is indicated.

KERNICTERUS

(Bilirubin Toxicity, Bilirubin Encephalopathy)

Unconjugated (indirect) bilirubin is neurotoxic, especially to basal ganglia in full-term neonates and to cranial nerve nuclei and thalamus in preterm neonates with birth weight < 1500 g. Hyperbilirubinemia with indirect bilirubin of 20 mg% or more, irrespective of the causative factor, can produce neurologic signs and symptoms in a newborn. In the case of a preterm and/or low birth weight infant, kernicterus may result from a lower level of bilirubin. The basal ganglia and other nuclear areas of the brain are the predominant sites of involvement.

The term, *transient bilirubin encephalopathy*, is reserved for early bilirubin-induced neurologic dysfunction which is temporary and reversible.

Etiology

The most common cause is the hemolytic disease of the newborn. But, conditions like Crigler-Najjar syndrome (*congenital glucuronyl-transferase deficiency*) can occasionally lead to this complication.

Predisposing or risk factors include pre- or post-maturity, VLBW, asphyxia, acidosis, hyperosmolality, sepsis as such or with meningitis, hypoalbuminemia, hypothermia, hypercarbia and rapid rate of rise of serum bilirubin.

Clinical Features

Manifestation of transient bilirubin encephalopathy is increasing lethargy with rising serum bilirubin level.

Manifestations may be categorized into three stages (Table 17.20).

Table 17.20: Staging of kernicterus (bilirubin encephalopathy)

Stage I	Poor feeding, lethargy, vomiting, high-pitched cry, poor Moro reflex, poor tone
Stage II	Fever, seizures, rigidity, opisthotonos, oculogyric crisis, paralysis of upward gaze, even death
Stage III	Reduction in spasticity
Stage IV	This is the stage of long-term sequelae in the form of spasticity, athetosis, deafness, mental retardation, dental dysplasia, paralysis of upward gaze, etc. (cerebral palsy).

Investigations

These include serum bilirubin, bilirubin binding tests, brainstem auditory evoked responses (BAER), high speed computer technology for cry analysis, PNMR spectroscopy and Brazelton neonatal behavioral assessment scale (BNBAS).

Treatment

A prompt exchange transfusion leads to recovery in transient bilirubin encephalopathy. Results in Stages I and II are equivocal.

Prognosis

Those who manage to survive are left with sequelae of extrapyramidal involvement, deafness, mental retardation, etc.

NEONATAL SEIZURES

Neonatal seizures constitute a common neonatal emergency, especially in preterm and LBW babies in whom

the incidence is many fold compared to the full-term healthy babies.

Etiology

Neonatal seizures are usually secondary to HIE, hypocalcemia, hypoglycemia or septicemia with meningitis (Table 17.21). For etiology of neonatal convulsions according to the time of onset, see Chapter 23 (Pediatric Neurology). These are never febrile or idiopathic.

Table 17.21: Etiology of neonatal seizures

<i>Developmental neurologic problems</i>	Congenital hydrocephalus, microcephaly, cerebral dysgenesis, porencephaly, polymicrogyria, pachygyria, hydrancephaly, lissencephaly, agenesis of corpus callosum.
<i>Perinatal complications</i>	HIE, birth asphyxia, birth injuries (especially with CNS involvement), intracranial bleed (IVH, SAH)
<i>Perinatal infections</i>	Meningitis, septicemia, intrauterine infections (STORCH)
<i>Metabolic problems</i>	Hypocalcemia, hypoglycemia, hypomagnesemia, hypo- or hypernatremia, pyridoxine dependency, severe hyperbilirubinemia with kernicterus (bilirubin encephalopathy), inborn errors of metabolism (amino acid metabolism, organic acidemias)
<i>Drugs</i>	Neonates born to mothers with narcotic addiction (narcotic withdrawal syndrome), theophylline, propylene glycol, advertent injection of local anesthesia
<i>Idiopathic</i>	

Clinical Features

Clinically, 5 major types of seizures are seen in neonates, namely subtle, generalized tonic, multifocal clonic, focal clonic and myoclonic. About 50% of all neonatal seizures are subtle which may manifest as eye movements (blinking, fluttering, deviation with jerking, eye opening sustained with ocular fixation), orobucolingual movements, screening, rowing and pedalling movements, apneic spells.

Pure tonic and clonic seizures are not seen in neonates since neonatal seizures are by and large subcortical in origin. Twitching, rolling of the eyes, generalized tonic stiffness without clonic phase but with apnea, or sudden irregularity of respiration or only a change in color with vacant look may reflect a convulsive disorder and should lead to evaluation.

Investigations

Investigations should include blood for calcium, phosphorus, and sugar, LP, and, in the interictal period,

EEG. A normal EEG does not rule out seizure activity. In certain cases it may become necessary to do ultrasonography and CT scan.

Treatment

Major steps of treatment are:

1. Stabilization of vitals (ABC)
2. Correction of metabolic abnormalities such as hypoglycemia and hypocalcemia
3. Anticonvulsant therapy.
 - Phenobarbital 20 mg/kg (IV) slowly over 10 minutes followed by, in case of no response, two doses, each 10 mg/kg, at 15 minutes interval. Total dose should not exceed 40 mg/kg. Maintenance dose is 5 mg/kg once a day.
 - If no response, Phenytoin, 20 mg/kg (IV) slowly over 20 minutes. (loading). Maintenance dose is 5 mg/kg once a day.

For intractable seizures, lorazepam, midazolam, clonazepam, valproate, paraldehyde, mag sulfate and even lignocaine may be employed (Table 17.22).

Table 17.22: Drugs for acute neonatal seizures

Phenobarbital (Gold standard)	10 - 20 mg/kg/dose (IV) 5 mg/kg/day (IV, O) as maintenance
Phenytoin	10- 20 mg/kg/dose (IV) 5 mg/kg/day (IV, O) as maintenance
Paraldehyde	0.15 ml/kg/dose (IM)
Lorazepam	0.05 mg/kg/dose (IV)
Diazepam (avoided)	0.5 mg/kg/dose (IV)

If the cause is not traceable and the response to anticonvulsants and/or correction of biochemical or metabolic defect is unsatisfactory, it is advisable to give a therapeutic trial with pyridoxine, 25 to 50 mg, calcium gluconate, 5 to 10 ml of 10% solution, by slow IV injection, and 1 to 2 ml/kg of 50% glucose, diluted with distilled water.

An infrequent, brief, simple, mild seizure that does not interfere with cardiorespiratory status need not be considered as an evidence of poor response.

The pediatrician may well reverse the order of anticonvulsant therapy and pyridoxine/calcium gluconate therapy depending on the merits of the case.

Unless there is an indication for long-term therapy, an anticonvulsant agent is continued for only 4 to 12 weeks following control of convulsions and then slowly withdrawn.

Prognosis

The best prognosis is in hypocalcemic seizures. Neonatal seizures secondary to birth trauma and hypoxia show bad outcome with almost 40% mortality in the neonatal period *per se*. Of the survivors, 25% suffer from recurrent seizures and neurodevelopmental defects.

NEONATAL HYPOGLYCEMIA

When blood glucose falls under 40 mg/dl, regardless of the gestational age of the neonate, hypoglycemia is said to be present. Its incidence, including both symptomatic and asymptomatic cases is approximately 20% in full-term and 50% in preterm/LBW babies.

Etiology/Predisposing Factors

Predisposing conditions include IUGR, prematurity, IDM, infants of toxemic mothers and smaller of the twins in case of *transient hypoglycemia* and, Rh incompatibility, prolonged hypoxia, hypothermia, septicemia, metabolic disorders like galactesemia, glycogen-storage disease, maple syrup urine disease or fructosemia, hyperinsulin states (leucine sensitivity, beta cell adenoma) exchange transfusion with ACD blood, etc. in case of persistent hypoglycemia.

The modus operandi of development of symptoms is release of epinephrine and activation of autonomic nervous system plus reduced utilization of glucose in the cerebrum.

Clinical Features

Clinical manifestations in symptomatic hypoglycemia include sweating, lethargy, irritability, jitteriness, tachycardia, tremors, cyanosis and apneic spells and seizures.

Treatment

Treatment in symptomatic neonates consists in giving a bolus dose of 10% dextrose, 2 ml/kg (IV) i.e. 200 mg/kg. In case of coexisting seizures, 4 ml/kg of 25% dextrose (IV) should be the choice.

This needs to be followed by IV dextrose, 4-10 mg/kg/minute until the blood sugar rises > 40 mg/dL.

Prednisone, 1-2 mg/kg/day (O) or hydrocortisone, 5 mg/kg, every 12 hours, is indicated if hypoglycemia remains unresponsive after 12 -24 hours of IV drip.

Glucagon, 300 mg/kg, IM or IV, (as such or in combination with epinephrine 1 in 10,000, 0.1-0.3 ml/kg IV, IM or SC) is indicated in hypoglycemia associated with maternal diabetes or Rh incompatibility.

Diazoxide, 25 mg/kg/day (IV, IM) in 3-4 divided doses is of particular value in intractable hypoglycemia in IDM.

Prevention

Initiating the neonate on breastfeeding within half an hour of birth and prevention of prematurity and LBW are important preventive strategies.

Prognosis

Neonatal hypoglycemia, if not controlled, may prove fatal. Some 50% of LBW and IDM survivors may show evidence of cerebral palsy, epilepsy or mental retardation.

NEONATAL HYPOCALCEMIA (*Neonatal Tetany*)

Newborns on cow milk formula (which is known to be rich in phosphates) may suffer from tetany. The condition is not uncommon.

Etiology

Predisposing factors include low birth weight, delayed feeding, maternal diabetes mellitus, difficult and prolonged labor, emergency Cesarean section and other complications associated with delivery, APH, toxemias, electrolyte disturbances (acidosis), congenital rickets, exchange transfusion with citrate blood, renal disorders, hypoproteinemia, idiopathic hypoparathyroidism and maternal hypoparathyroidism (DiGeorge syndrome).

Clinical Features

Clinical manifestations include tremors, twitching, jitteriness, frank seizures (towards end of first week of life) and, infrequently, laryngeal spasm and carpopedal spasm. The baby remains all right in between the attacks.

Chvostek sign, a normal finding in a neonate, is not of value.

Association of tetany with intractable thrush (moniliosis) and failure to thrive must invite attention to the possibility of DiGeorge syndrome or thymic hypoplasia (Chapter 29: Immunology).

Investigations

Serum calcium is reduced, almost always below 8 mg/dl. Serum phosphate is, however, high.

ECG shows prolonged QTc interval.

In selected situations, chest X-ray is helpful to exclude thymic hypoplasia or aplasia.

Treatment

Treatment consists in administering 5 to 10 ml (2 ml/kg) of 10% calcium gluconate, very slowly, by intravenous route. Response is dramatic. Later, the baby should be put on maintenance oral calcium gluconate, 2 to 3 g/day in a 10% solution in divided doses, for several weeks. If the baby had been on cow milk, he should be shifted to mother's milk.

If response to calcium therapy is poor, the infant should be administered intramuscular magnesium sulfate (*vide infra*).

NEONATAL HYPOMAGNESEMIA

When serum magnesium levels fall under 1.5 mg/dl (0.62 mmol/l), biochemical hypomagnesemia is said to be present. However, clinical manifestations of hypomagnesemia usually develop when the levels fall under 1.2 mg/dl.

The etiologic factors include inadequate placental transfer, poor intestinal absorption, hypoparathyroidism, hyperphosphatemia, renal loss, defective magnesium and calcium homeostasis, exchange transfusion, TPN, and infants of diabetic mothers. Occasionally, it may coexist with hypocalcemia.

Manifestations are indistinguishable from those seen in hypocalcemia and tetany. Perhaps, hypomagnesemia causes symptoms through accompanying hypocalcemia.

In the diagnosis, the most vital clue is hypocalcemic seizures/tetany not responding to adequate calcium therapy.

Treatment comprises immediate administration of magnesium sulfate, 0.25 ml/kg of a 50% solution, intramuscularly. Usually a 1 to 2 week therapy in the same dose (IM, O) suffices.

INFANTS OF DIABETIC MOTHERS (IDM)

Etiopathogenesis

Maternal diabetes may cause fetal death in third trimester of pregnancy.

Clinical Features

Newborns of diabetic mothers, who themselves may have suffered from toxemia of pregnancy and hydramnios, are usually remarkably heavy, plump, full-faced (macrosomia), plethoric and covered with lot of vernix caseosa. Mortality, both *in utero* and neonatal life, is relatively high.

Such infants are prone to develop hypoglycemia, hypocalcemia, idiopathic respiratory distress syndrome, hyperbilirubinemia, polycythemia, persistent pulmonary hypertension, cardiomyopathy, lazy left colon syndrome, renal and adrenal vein thrombosis and congenital malformations, including those of skeleton, heart, and respiratory system. Hypertrichosis and hairy pinna are striking signs.

Treatment

Unlike in the past, it is a practice nowadays to allow the pregnancy to reach closer to term while a good antenatal check-up is maintained on fetal growth and the attending obstetrician ensures control of maternal diabetes.

The infant is treated in the same way as a preterm or light-for-dates, preferably in an incubator. It is helpful to administer 10% glucose at a rate of 10 ml/hour. Oral feeding should be introduced at 12 hours or as early as possible) if there is respiratory distress.

Prognosis

Only 1 to 2% of such babies may end up with diabetes mellitus in childhood.

NEONATAL COLD INJURY (*Hypothermia*)

Already described in this very chapter.

NEONATAL HYPERTHERMIA

In tropical climates, infants with inadequate fluid intake, and infants exposed to high environmental temperature which may be in natural sun, in an incubator, in a phototherapy unit or in a bassinet close to a room heater or radiator, may occasionally develop on second or third day hyperthermia with a body temperature of 38 to 39°C.

Manifestations in these infants include restlessness, irritability, weight loss, diminished frequency and output of voiding, loss of skin elasticity, depressed anterior fontanel, and thirst. Infrequently, tachycardia

and tachypnea develop. In contrast to the sick-looking neonate when infection is the cause of high temperature, in this condition, also termed *dehydration fever* or *transitory fever* of the newborn, he shows vigor, taking fluid avidly.

Response to rehydration or lowering of environmental temperature is excellent.

A severe form of hyperthermia develops in neonates and infants who are warmly dressed for the low outdoor temperature and left close to a heater in a room or made to travel in a warm vehicle. The poor sweating capacity of the neonate contributes to development of fever with a temperature as high as 41 to 44°C.

Manifestations include flushing, apathy, dry and warm skin. Later, stupor, grayish pallor, coma, seizures and hemorrhagic shock may follow. Sudden death may occur at usual room temperature or immersion in tepid water. Fluid and electrolyte imbalance, if present, should also be corrected.

Prevention consists in dressing the infant in clothing appropriate for the temperature of the immediate environment.

SCLEREMA

The term is applied to solidification of the subcutaneous fat.

Etiopathology

Sclerema should arouse suspicion of cold injury, gram-negative septicemia or hypernatremic dehydration. Irrespective of the underlying cause, the neonate is in a moribund state.

Histologic changes include broadening of the trabecular fat and diminution in fat spaces. There is no cellular infiltration.

Clinical Features

The overlying skin becomes hard and stretched and cannot be pinched. The condition first makes its appearance over the face and the legs. Thereafter, it spreads in a centripetal fashion. With the involvement of the thorax, respiratory difficulty (shallow and rapid breathing) and cyanosis may occur.

Treatment

Therapy is directed at the underlying cause together with high doses of steroids.

Prognosis

Prognosis is usually grave. Recovery occurs, despite aggressive treatment, only in a small proportion of cases.

NEONATAL NECROTIZING ENTEROCOLITIS

This is a poorly understood disorder of the newborn in which the baby develops lethargy, vomiting, bloody diarrhea, distention of abdomen, hypothermia and apnea. Terminally, he may go into cardiovascular collapse.

Etiology

The condition is encountered usually in low birth weight babies born before term. It may however, occasionally, develop even in normal full-term babies. Predisposing factors include maternal fever, amnionitis, sepsis, respiratory distress syndrome (usually of mild type) exchange transfusion and oral feeding with high osmolar (hypertonic) stuff.

Investigations

Investigations show air-fluid levels, dilated loops of gut, separation of loops of gut and linear streaks of intraluminal air, *pneumatosis intestinalis*, which confirm the diagnosis.

Treatment

Treatment is with antibiotics, substitution of enteral feeds by intravenous fluids and supportive measures to maintain temperature.

Prognosis Prognosis is bad. High mortality may result from such complications as perforation, abdominal wall cellulitis, and pneumoperitonitis. Suspicion of such complications has a complication indicates a laparotomy.

A sequel of the conservatively managed cases is colonic stenosis.

TRACHEOESOPHAGEAL FISTULA

See Chapter 40 (Pediatric Surgery).

CONGENITAL DIAPHRAGMATIC HERNIA

See Chapter 40 (Pediatric Surgery).

IMPERFORATE ANUS

See Chapter 40 (Pediatric Surgery)

TRANSPORT OF SICK NEONATES

Types of Neonatal Transport

The following types of neonatal transport are usually required:

- From village level to level I center
- From level I to level II center
- From level II to level III center
- From labor room to nursery with level II or III facilities
- From NICU to operation theater.

Indications for Transport

A. In Utero Transport

Table 17.23 gives indications of *in utero* transport if the birth of an at risk neonate is anticipated.

B. Postnatal Transport

Table 17.24 gives the list of danger signs of a sick neonate that should guide the health workers to transport the neonate to an institution.

Table 17.25 gives the indications for transport of sick neonates to neonatal intensive care unit.

Major Principles of Transport

- Ensuring that full justification for transport exists and explaining it to the parents/attendants
- Ensuring communication of arrival of the sick baby to the referral center and providing all the case record to the attendants for the benefit of the referral center.
- Before transporting the neonate, ensuring that he is stabilized as far as possible, especially in regards to his hypothermia.
- Ensuring warmth (thermal stability) for the neonate during transport. The most practical method in developing countries is keeping the neonate close to the mother's chest, making available the skin-to-skin contact.
- Providing instructions and guidelines to the attendants for care during transport. In case of an IV line, the attendants should know about the number of drops/minute as also the technique of changing the bottle.
- The reverse transport should also be communicated to the referring unit, say from NICU to postnatal wards or back to the community health center.

Table 17.23: Indications of *in utero* transport/referral

- Onset of premature labor in a pregnancy of 33 weeks or less
- Multiple pregnancy or abnormal presentation
- Antepartum hemorrhage and pre-eclampsia
- Cephalopelvic disproportion
- Prolonged rupture of membranes, especially in the presence of maternal infection
- Serious maternal cardiovascular or renal disorders
- Previous severe isoimmunization or other serious fetomaternal problems
- Fetal anomalies like diaphragmatic hernia or tracheoesophageal fistula
- IUGR, especially with oligohydramnios

Table 17.24: Danger signs that indicate transport from the community to the institution with at least level II facilities

- Poor sucking
- Rapid or difficult breathing with a rate > 60/minute and/or indrawing of chest spaces
- Cold clammy or too warm skin
- Abnormal movements including stiffness and uprolling of eyes
- Abdominal distention
- Jaundice

Table 17.25: Indications for transport of sick neonates to neonatal intensive care unit (NICU)

Status	Absolute indication	Relative indication
LBW	< 1500 g	1500-2000 g
Prematurity	< 32 weeks	32-36 weeks
Respiratory distress	moderate to severe, not improving with oxygen Airway obstruction Apnea	Mild respiratory distress
Fulminant infection	Septicemia Meningitis Pneumonia Tetanus	
Shock	Hypotension Oliguria	
Birth asphyxia	HIE	
Congenital malformations	Diaphragmatic hernia TEF Intestinal obstruction Congenital heart disease (Symptomatic acyanotic and all cyanotic)	Congenital heart disease (asymptomatic) Gastroschisis
Miscellaneous	Severe hyperbilirubinemia Birth trauma	IDM Neonatal seizures Coagulopathy Genetic/metabolic disorders

MATERNAL MEDICATION AND ADVERSE EFFECTS ON THE FETUS

As a rule, all medication to the pregnant mother should be avoided unless and until the attending doctor finds that the benefits of a particular medicine outweigh its risks to the fetus (Table 17.26). The risk of teratogenic effect is most pronounced during embryogenesis. In later pregnancy, the adverse effects are in the form of disturbance of enzyme system or organ dysfunction.

Table 17.26: Maternal medication and adverse effects on fetus

Drugs	Adverse effects (teratogenic)
Diazepam	Cleft lip, cleft palate, hypothermia, apnea
Quinine	Deafness, thrombocytopenia, neurologic anomalies
Chloroquine (prolonged use)	Deafness
Sulfas	Hyperbilirubinemia
Streptomycin	Eighth nerve deafness, renal damage
Tetracyclines	Deposition in teeth, staining of teeth, enamel hypoplasia, retardation of bone growth, congenital cataracts
Propranolol	Growth retardation, thrombocytopenia
Indomethacin	LBW, platelet dysfunction
Heroin	Intrauterine death, LBW, SIDS
Phenobarbital	Cleft lip, cleft palate, CHD, respiratory depression, withdrawal symptoms
Phenetoin	Various malformations in relation to limbs, heart and face
Valproate	Facial anomalies, spina bifida, developmental delay
Smoking	LBW, abnormal placentation
Alcoholism	IUGR, mental retardation, microcephaly, flexion contractures
Diethylstilbesterol or Progesterone	Genitourinary anomalies in males, adenosis carcinoma of vagina in females Masculinization of female fetus with testosterone
Iodides (in third trimester)	Congenital goiter, hypothyroidism
Cyclophosphamide	Multiple deformities
Progesterone (in third trimester)	Malformations of external genitalia, postpubertal vaginal adenocarcinoma
Sulfonurea (third trimester)	Neonatal hypoglycemia, brain damage
Thalidomide (in third trimester)	Limb deformities, defects of CVS, ears and eyes
Radiation	Mental retardation, microcephaly

* Amongst antiepileptic drugs (AEDs), the most teratogenic are phenytoin, valproate and trimethadione. The safest are carbamazepine, phenobarbital and primidone.

MATERNAL MEDICATION AND ADVERSE EFFECTS ON BREASTFED INFANT

Table 17.27 lists the adverse effects of medication on breastfed infants.

Table 17.27: Adverse effects of maternal medication on breastfed infants

Drug/agent	Adverse effect
Antithyroids	Hypothyroidism
Phenobarbital	Drowsiness, rickets, drug rash, methemoglobinemia
Phenytoin	Rickets, drug rash, methemoglobinemia
Diazepam	Drowsiness, rise in serum bilirubin
Laxatives	Loose motions
Penicillin	Rash
Narcotics	Withdrawal symptoms
Theophylline	Irritability
Lithium	Hypotonia
Sulfas	Drug rash, hemolysis
Salicylates	Drug rash, interference in platelet function
Oral contraceptives	FTT, gynecomastia

FOOD AND ENVIRONMENTAL AGENTS AND ADVERSE EFFECTS ON THE INFANT

These are summarized in Table 17.28.

Table 17.28: Food and environmental agents having adverse effect(s) on the infant and/or lactation

Food /environmental agent	Adverse effect(s)
Chocolates	Irritability, diarrhea (if the mother consumes > 16 oz/day)
Fava beans	Hemolytic anemia in G-6-PD deficiency
Absolute vegetarianism	Vitamin B ₁₂ deficiency
Hexachlorbenzene	Rash, diarrhea, vomiting, dark discoloration of urine, neurotoxicity
Lead	Neurotoxicity
Mercury	Retarded neurodevelopment
Tetrachloroethylene	Dark discoloration of urine, obstructive jaundice

FURTHER READING

Articles/Chapters

1. American Heart Association/American Academy of Pediatrics. 2005 American Heart Association (AHA) guidelines for cardiopulmonary resuscitation (CPR) and emergency cardiovascular care (ECC) of pediatric and neonatal patients. Neonatal resuscitation guidelines. *Pediatrics* 2006;117:e1029-e1038.
2. Bansal S, Dhawan A (Editorial). Neonatal cholestasis syndrome: the saga continues. *Indian Pediatr* 2000;37:627-630.
3. Gupte S. Medication and the breastfeeding mother. *Perinatology* 1999;1:240.
4. Gupte S. Congenital malaria in north India. In Mir NA, Hassan M (Eds). *Current Trends in Perinatal Medicine*, Srinagar 1987:127.
5. Laroia N. (Editorial). Current controversies in diagnosis and management of neonatal seizures. *Indian Pediatr* 2000;37: 367-372.
6. Ment LR, Vohr B, Allan W, et al. Change in cognitive function over time in very low birthweight infants. *JAMA* 2003; 289:705-711.
7. Sarin M, Dutta S, Narang A. Randomized controlled trial of compact fluorescecent lamp versus standard phototherapy for treatment of neonatal hyperbilirubinemia. *Indian Pediatr* 2006;43:583-591.

Books/Monographs

1. Guha DK. *Neonatology: Principles and Practice*, 2nd edn. New Delhi: Jaypee 1998.
2. Gupte S. *Recent Advances in Pediatrics (Special Vol 12: Neonatal Emergencies)*. New Delhi: Jaypee 2003.
3. Gupte S (Ed). *Recent Advances in Pediatrics (Special Vol. 4: Neonatology)*, New Delhi: Jaypee 1999.
4. Gupte S (Ed). *Recent Advances in Pediatrics (Special Vol. 5: Neonatology-2)*. New Delhi: Jaypee 2000.
5. Kulkarni ML. *Manual of Neonatology*. New Delhi: Jaypee 2000.

PART THREE



Pediatric Infections



Pediatric Viral Infections

Ksh Chourjit, Suraj Gupte

SMALLPOX (VARIOLA)

This, a highly contagious disease of man, known since its earliest description by Sushruta, the Father of Plastic Surgery, in 600 BC, has now become a part of history.

A large DNA virus, belonging to the poxviruses, is the etiologic agent (Figs 18.1 and 18.2).

Two types, i.e. *variola major* and *minor*, can be distinguished by the severity of the manifestations it causes.

Today, thanks to the WHO's Smallpox Eradication Program, the disease has been wiped out the world over. Let this be our goodbye, nay goodbye forever, to smallpox which had been endemic in 30 countries and imported in many more until 1967 when the WHO launched effective war against it.

Though it was in 1980 that smallpox was declared as "eradicated worldwide", the 49th World Health Assembly decided to retain 500,000 doses of the smallpox vaccine and destroy the rest of the stock held in two research centers in the Russian Federation and the United States of America. The smallpox vaccine seed virus (vaccinia virus strain Lister Elstrea) is maintained in the WHO Collaborative Center on Smallpox Vaccine at the National Institute of Public Health and Environmental Protection in Bilthoven, Netherlands. The aim is to be in a position to produce new stock of vaccine as and when needed (Fig. 18.3).

MONKEYPOX: A NEW CHALLENGE

Despite the worldwide eradication of smallpox, we continue to have *monkeypox* as a sporadic disease in



Figs 18.1 and 18.2: Classical smallpox. Note the predominantly peripheral distribution of the rash with hard shotty feel and at the same stage of development. This is in remarkable contrast with the picture seen in chickenpox



Fig. 18.3: Ali Maow Maalin, a cook from Somalia, was the last person to suffer from smallpox. Between the end of November, 1977 (when Maalin had completely recovered) and today, no smallpox case has been reported with the sole exception of a laboratory infection. Official WHO declaration on complete eradication of smallpox from earth was made in 1980 only

parts of Africa. The virus is related to the virus that caused smallpox and may cause clinical presentations in humans similar to those seen in smallpox cases in the past. The recent outbreak in Zaire (now rechristened Republic of Congo) happens to be the largest cluster of monkeypox cases ever recorded as per 1997 report of the WHO.

CHICKENPOX (VARICELLA)

It is another highly communicable, though generally mild, viral infection of childhood. In adolescents and adults, it tends to be rather serious with complications like *varicella bronchopneumonia*. It may prove fatal in immunocompromised children. Unlike smallpox, chickenpox does not always confer permanent immunity and second attack infrequently occurs. There is no age bar though a large majority of the cases are young children (5-10 years).

Etiopathogenesis

The causative agent is a DNA virus, varicella zoster virus (VZV), which may remain latent and cause herpes zoster in later life.

The mode of transmission resembles that of smallpox. The spread is by direct or indirect contact; air-borne infection is rather uncommon. About 90% of the nonimmune inmates of the house are affected.

Epidemiology

Chickenpox is worldwide in distribution, occurring in both temperate and tropical regions. It shows some seasonal variation, the peak incidence being during winter and summer (January- May). Five to 10 years is the peak age incidence though the disease may occur at any age including neonatal period.

Dominant pathologic changes are limited to skin and to some extent to the respiratory tract.

The patient is infective to others a day before and 5 days after the onset of symptoms.

Exposure to herpes zoster may cause initiation of chickenpox epidemic.

Clinical Features

The incubation period is 15 days, the range being 11 to 21 days.

The *prodromal phase* of slight malaise, low-grade fever, headache, backache and shivering is short (just 24 hours) and may not be noticed.

Thus, the onset may be sudden with appearance of a rash, the first sign in majority of the cases. The eruption passes through all the stages encountered in smallpox, i.e. macule, papule, vesicle, pustule and crust. The progression of the rash is, however, much rapid. The complete evolution takes about 4 to 7 days followed by scab formation. The scabs (crusts) fall off within 2 weeks of first appearance of rash. These are not infective since virus is present in vesicles and not in crusts.

It is worth remembering that skin lesions of chickenpox appear in 2 to 4 crops so that all stages and sizes may be seen at the same time. Furthermore, these are superficial, pleomorphic and centripetal in distribution and are seen over the scalp and mucous surfaces (including conjunctiva) first and then over the body. The trunk is profusely covered whereas extremities and face are only scantily involved. Axilla is affected but the palm and sole are usually spared. Occasionally in children under 2 years of age, chickenpox lesions may be in the form of bullae rather than vesicles. This variant of the disease is termed *varicella bullosa*.

The constitutional symptoms include some fever when most vesicles have reached the pustular stage. Itching is mild at first but may become severe in the pustular stage.

Hemorrhagic, neonatal and even congenital chicken-pox may infrequently be seen. In case the mother develops chickenpox between 5 days before and 5 days after delivery, 15 to 20% neonates develop this infection. Mortality in them is as high as 30%. Maternal infection may damage the fetus, causing embryopathy with limb atrophy, scarring of skin, and ophthalmic and meningeal lesions (Box 18.1).

Box 18.1: Congenital varicella syndrome (varicella embryopathy)

<i>Maximum risk</i>	8-20 weeks of gestation
<i>Cause</i>	Virus-induced injury to CNS with predilection for tissues that are in a rapid developmental stage like limb buds.
Stigmata	
<i>Skin</i>	Cicatrix presenting as a zig-zag scarring in a dermatomal distribution; hypopigmentation
<i>Brain</i>	Aplasia, microcephaly, hydrocephaly, calcification
<i>Spinal cord</i>	Shortened or malformed limbs, motor/sensory deficit, absent deep tendon reflexes, anisocorbia, Horner syndrome, anal and urinary sphincter dysfunction
<i>Eye</i>	Microphthalmia, cataracts, optic atrophy, choreoretinitis.

Diagnosis

It is more or less clinical. The disease had got to be differentiated from smallpox earlier. Early in disease, the papules of chickenpox may need to be differentiated from pyoderma. Other differential diagnoses include insect bite, papular urticaria, and, rarely, molluscum contagiosum.

Laboratory diagnosis is difficult. WBC count is usually normal or little low, except in event of a superadded bacterial infection when it is high with polymorphonuclear response.

In the fluid from skin lesions, multinucleated giant cells containing intranuclear inclusions may be seen.

Remaining confirmatory tests include immunofluorescent staining of scrapings from vesicles with monoclonal antibodies, indirect fluorescent antibody, latex agglutination and ELISA.

Complications

In a majority of the cases, chickenpox runs a benign course. The potential complications are listed in Table 18.1.

Table 18.1: Complications of chickenpox

Cutaneous

- Superadded skin infection with streptococci or staphylococci, i.e. cellulitis, abscess, etc.
- Purpura fulminans (from DIC)
- Idiopathic (immune) thrombocytopenic purpura (ITP)

Systemic

- Bronchopneumonia usually due to superadded bacterial infection; rarely varicella pneumonia.
- *Neurologic*: Encephalitis (including Reye's syndrome), cerebellar ataxia, transverse myelitis, polyradiculitis, Guillain-Barré syndrome, facial nerve palsy, optic neuritis with transient loss of vision, a hypothalamic syndrome with recurrent pyrexia and obesity, etc
 - Septicemia
- Suppurative arthritis/osteomyelitis
- Myocarditis
- Bleeding diathesis due to thrombocytopenia or disseminated intravascular coagulation (DIC)
- Glomerulonephritis
- Hepatitis
- Appendicitis
- Myositis
 - Reye's syndrome (if aspirin given)
 - Herpes zoster (late complication).

Treatment

No specific treatment is available.

Acyclovir (Zovirax) claims to accelerate rate of clinical and skin lesion improvement, to reduce number of skin lesions, and to cause speedy deferescence. The therapy is quite expensive. Until more convincing evidence becomes available for its utility in routine cases of chickenpox, its administration should be restricted to immunocompromized subjects who develop chickenpox or varicella pneumonia. The dose is 20 mg/kg/dose 4 times daily for 5 days.

General and supportive measures include:

- Antipyretics for fever. Aspirin, however, needs to be avoided since it may enhance the risk of developing Reye syndrome in subjects with varicella.
- Itching may be relieved by systemic antihistaminics and/or local application of calamine lotion, potassium permanganate, etc. and sponge baths with antiseptic detergents.
- Nails must be cut short.
- Mouth and perineal regions may be treated by rinses, gargles and saline soaks.

Secondary infections require appropriate antibiotics. In *varicella pneumonia*, antibiotics, are not of much value.

Steroids are, as a rule, contraindicated. General measures for encephalitis are outlined in Chapter 23.

Children suffering from chickenpox must be restrained from attending the school for 6 days after the appearance of the rash.

Prophylaxis

A live attenuated chickenpox vaccine which gives an efficacy of 80% in safeguarding against the disease (provided that it is administered within 3 days of exposure to a case of chickenpox) or significantly reducing the intensity of the disease, is available. Dose: 0.5 ml (SC). In case of the vaccine from Glaxo, Smith Kline (*Varilrix*), 2 doses for children 13 year and above at 6-10 weeks gap are recommended. The vaccine from Aventis Pasteur (*Okavax*) is recommended as a single dose. The vaccine is quite safe and well tolerated but expensive. Mild to moderate rash may appear in some cases.

Zoster immunoglobulin (ZIG) or varicella zoster immunoglobulin (VZIG), which are equally effective (the former is not easily available), are indicated for inducing passive immunity in the following situations:

- Children at high risk of severe varicella, e.g. immunocompromised states like immunodeficiency diseases, leukemia or malignancies, and those on immunosuppressive drugs.
- Neonates whose mothers develop varicella within 2 days before and 5 days after delivery.
- Probably susceptible pregnant women exposed to varicella, especially if antibody testing turns out to be negative.

The recommended dose of VZIG is 125 units/10 kg and that of ZIG 5 ml (IM).

Schools must insist on isolation of children with chickenpox at least till 6 days of appearance of the rash to safeguard against an epidemic.

Prognosis

Chickenpox carries, as a rule, favorable prognosis. Nevertheless, such complications as varicella pneumonia and encephalitis, especially in immunocompromised hosts, may prove fatal.

MEASLES (RUBEOLA)

It is the most common and the most infectious of the viral infections of childhood. It is characterized by



Fig. 18.4: Measles: Note the classical pink, blotchy, irregular macular rash first involving the face and retroauricular area

catarrhal symptoms followed by a typical rash, the so-called measles rash.

Measles is a frequent cause of ill health and morbidity, especially in the undernourished infants and children below the age of 3 years. In healthy children, it generally runs a more or less benign course.

Measles is unusual before the age of 3 to 4 months and mild in the next 6 months. This is because of the protection provided by the maternal antibodies. The peak incidence in the developing world is in the age group 1 to 5 years. One attack confers nearly life-long immunity (Fig. 18.4).

Etiopathogenesis

The causative agent is the specific *measles virus*, a RNA virus (paramyxovirus*).

Transmission is by indirect or direct contact and droplet infection. The period of infectivity is 4 days prior to and 5 days after the appearance of the rash. Pathological changes are essentially limited to superficial blood vessels of skin and mucous membrane, forming the so-called "inclusion bodies" (Figs 18.5 and 18.6).

* Mumps and parainfluenza also belong to this group



Fig. 18.5: Measles. Note that the rash has spread all over the body



Fig. 18.6: Measles. Note the light-brown staining (pigmentation) left behind as the rash is gone away

Epidemiology

Measles is a worldwide disease. Both epidemic and endemic existence is known. Highest incidence is in winter and spring. Poorer the community, higher the occurrence of the infection at lower age.

The disease is the focus of strange beliefs. As for instance, it is generally regarded as “curse of the

goddess”. Either no medicines or the ones which are supposed to cause greater eruption are preferred by the folklore. Such harmful practices as fomentation with hot bricks, instilling cow milk drops in nostrils and eyes, and giving a purge in order to bring the rash out fully are common. Also, during the illness, the “child should receive only negligible food or fluids”. It is generally held that measles is not a good reason to consult a doctor. Instead, the parents prefer to visit the temple. All this adds up to the problems of the child with measles.

Clinical Features

The average incubation period is 11 days, the variation being between 10 to 12 days provided that onset is ascribed to the first prodromal symptoms.

Three stages are known: (i) prodromal, (ii) eruptive, and (iii) convalescent.

Prodromal (Catarrhal) phase of 3 to 5 days is characterized by upper respiratory catarrh, fever, malaise, conjunctivitis and photophobia. Posterior cervical lymphadenopathy may accompany these early manifestations. This phase is also called *catarrhal stage*. Another important feature of this phase is the appearance of the *Koplik's spots*. There are fine, tiny grain-like papules on faint erythematous base. Their first appearance is over the buccal mucosa, opposite the first lower molar, and then at other sites in the mouth. Koplik's spots are pathognomonic of measles and usually disappear by about 5th day, usually a day after the rash appears. In practice, these are observed in only a small proportion of cases.

Eruptive phase is characterized by a rash which appears 3 to 5 days after the onset of the disease. With the appearance of rash, fever tends to regress but takes another three days to disappear. It is seen far better in day light than in artificial light. Its special features are:

- Pink, blotchy irregular macular erythema. It fades on pressure and quickly darkens and blends into large red patches of varying size and shape.
- Face and areas behind the ears (retroauricular area) are the sites of its first appearance. Then it spreads to neck, trunk and limbs during the following 3-4 days. It is frequently accompanied by cervical lymphadenopathy.

- It lasts for 4 to 7 days. Mild itching may accompany it. The rash starts fading from 3rd to 4th day, disappearing in the order of appearance.
- Eventually, there results a fine shedding of the superficial skin of face followed by that of trunk and limbs, leaving behind a light-brown pigmentation.

Convalescent phase is marked by disappearance of fever, other constitutional symptoms and the rash.

Diagnosis

3 It is primarily clinical, needing no investigations.

The leukocyte count is low but slowly rises to normal as the rash fades. In case of superadded bacterial infections, a sharp leukocytosis often occurs.

Measles-specific IgM antibody persists for 30-60 days following the rash.

ELISA and hemagglutination inhibition are the most sensitive for detecting measles antibodies which, if increased 4 times, are diagnostic of measles.

Today, it has become possible to isolate the virus from the nasopharynx or blood, especially during the acute stage. Even 10 to 20 days after the onset, complement-fixation antibodies in meaningful titer may be detected.

Differential Diagnosis

At times, another supposedly viral infection of infant and toddlers, *roseola infantum* (*roseola subitum*, *fifth disease*), may be confused with measles. The pink macular rash of the infection usually appears on trunk, neck and proximal areas of the extremities only. It lasts for just 24 hours as against measles in which the rash lasts for 4 to 7 days.

In *rubella*, the rash is discrete and mild. There is significant posterior occipital lymphadenitis. Prodromal phase is slight and short.

Infectious mononucleosis (glandular fever) is characterized by rash*, fever, generalized lymphadenopathy and hepatosplenomegaly. It is caused by Epstein-Barr virus and is benign.

In *drug rash*, a history of the rash following intake of a drug may be of help.

In *meningococemia*, other signs of the disease, such as meningitis, toxemic state of the patient, etc. are usually present.

* Interestingly, the rash often becomes manifest following administration of ampicillin

In *typhus*, the rash is centripetal. The patient is very toxic.

Miliaria rubra (*prickly heat*, *sudamina*, *heat rash*) causes pinhead sized erythematous papules over the areas where sweat glands are in abundance. It is usually seen in summer.

Complications

The potential dangers of measles lie in its complications (Table 18.2) rather than in the disease *per se*.

Table 18.2: Complications of measles

Immediate Complications

- Otitis media tops the list of respiratory complications.
- Tracheobronchitis, laryngotracheobronchitis, bronchiolitis, bronchopneumonia subcutaneous emphysema* etc. Rarely, measles virus may spread to the lung parenchyma, causing the so-called "*giant-cell pneumonia*" which may prove fatal. Measles pneumonia in AIDS may occur without any rash. It often proves fatal.
- Stomatitis, enteritis and even cancrum oris (noma), especially in malnourished children.
- Activation of existing tuberculosis with transient loss of hypersensitivity to tuberculin.
- Keratitis and corneal ulceration secondary to vitamin A deficiency that commonly follows measles.
- Bleeding diathesis, the so-called *hemorrhagic measles*. It has a stormy onset with high fever, convulsions, delirium, coma and bleeding. Also termed "*black measles*", it has a fatal outcome.
- Appendicitis
- Malnutrition
- *Encephalitis* is rare (just 0.1 percent) but the most dreadful of all. The survivors are invariably left with residual sequelae, including mental retardation.
- Remaining CNS complications such as Guillain-Barré syndrome, cerebral thrombophlebitis, hemi-plegia, and retrobulbar neuritis are still rarer.
 - Acute glomerulonephritis
 - Steven-Johnson syndrome
 - Decreased cell-mediated immunity and anergy (during few weeks after attack)
- Transient ECG changes and myocarditis (uncommon)

Late Complication

- Very rarely, subacute sclerosing panencephalitis (SSPE), a universally fatal disease, may result as a long-term sequelae on an average of 6 years (range 3-6 years) after the attack of measles. It is characterized by myoclonic jerks and mental deterioration. It behaves like a degenerative disorder

* Other cause of subcutaneous emphysema include trauma, asthma, pertussis, foreign body, violent cough, etc.

Treatment

No specific treatment is available. General measures consist of isolation, cough sedatives, vasoconstrictor nasal drops, antipyretics, attention to eye and mucous membrane of mouth, antihistaminics for itching, and maintenance of proper fluid and dietary intake and vitamin A administration to reduce the morbidity from measles.

In case bacterial infection is superimposed, suitable antibiotic(s) should be given.

Antiviral agents are not of proven value.

Gammaglobulins, hyperimmune gamma globulins and steroids are of doubtful value.

Prophylaxis

Isolation of the affected child is warranted.

Active immunization is provided by measles vaccine at 9 months and then at 15 to 18 months in the form of MMR (Chapter 10).

Passive protection can be achieved with gamma-globulins in the following situations:

- 0.2 ml/kg to prevent occurrence of measles in debilitated susceptible contacts unable to withstand the illness.
- 0.04 ml/kg to healthy susceptible contacts in whom it is desirable to have mild attenuated measles.

GERMAN MEASLES* (RUBELLA, THREE-DAY MEASLES)

It is a relatively less contagious viral infection, characterized by mild prodromal symptoms, a typical eruption and enlargement of cervical lymph nodes. It is primarily a disease of older children and adults. Second attack is rare.

Etiopathogenesis

The causative agent is a *myxovirus*. Transmission is by droplet infection and direct contact. The virus enters the host through the upper respiratory route. The period of infectivity is 5 days prior to and 4 days after appearance of rash.

Clinical Features

The incubation period is around 16 days. The range is 14 to 21 days.

Prodromal phase lasts for a few days. Slight malaise and, occasionally, tender posterior cervical lymphadenopathy without any catarrh may be there. The phase may be entirely absent or remain unnoticed.

Rash may be the first visible sign. This is especially so in case of small children. To start with, it is a macule which spreads from face to trunk and extremities. Macules later blend. The eruption disappears by the third day. There may be slight fever for 2 days.

In certain instances, rash may not appear at all. In this situation, febrile lymphadenopathy may be there for a week or more.

Congenital rubella syndrome Over the years, there has been a growing recognition of the fact that infants born to mothers who had suffered from rubella, particularly in the first trimester (more so first month) of pregnancy, may suffer from multiple congenital defects. This condition has been called the *congenital rubella syndrome*. In 1960s, a more detailed picture of this syndrome emerged, earning it the name *extended* (or *expanded*) *congenital rubella syndrome*. Its important manifestations are:

- Growth retardation
- Congenital heart disease (patent ductus arteriosus)
- Mental retardation and microcephaly
- Hepatosplenology and hepatitis
- Thrombocytopenia and purpura
- Deafness
- Otitis media
- Pancreatitis
- Pneumonitis
- Cerebral diplegia
- Cleft palate and foot
- Syndactyly
- Spina bifida and talipes equinovarus
- Dental malformations
- Microphthalmia
- Buphthalmos
- Cataracts (Fig. 18.7)
- Retinal lesions: Salt and pepper retinitis.

Progressive rubella panencephalitis (PRP) is an exceedingly rare chronic encephalitis as a result of persistent rubella virus infection of the CNS. The illness behaves like subacute sclerosing panencepha-

* Thus named since it was earlier thought to be a variant of measles by the German physicians



Fig. 18.7: Congenital cataract (bilateral). The child had several other features of congenital rubella syndrome, including mental retardation, deafness, patent ductus arteriosus, syndactyly and hepatosplenomegaly

litis (SSPE). Rubella virus has been isolated from brain cell culture and from separated blood lymphocytes of these patients.

In a newborn with congenital rubella syndrome, virus can be recovered from nasopharyngeal washings, CSF, blood, stools or urine. This virus may persist until the baby is of 12 to 18 months of age.

Diagnosis

Clinical suspicion is of vital importance. Diagnostic tools include:

- Virus isolation, and
- Serological tests, e.g. neutralization, complement-fixation, hemagglutination inhibition, fluorescent antibody studies, ELISA, etc.

Treatment

Unfortunately, there is nothing specific (not much otherwise too) at physician's command. If complications like encephalitis, polyarthritis, neuronitis, etc. are present, these should be tackled accordingly. Treatment with such agents as interferon or isoprenosine has not yielded encouraging results.

Prophylaxis

The only reliable means of preventing German measles is the administration of the *vaccine* (rubella

vaccine as such or MMR) at 15-18 months age (Chapter 10). Even though there is a history of a young girl having suffered from this disease in the past, it will be a sound policy to administer this vaccine to her to be more certain of the protection.

Gammaglobulin, though employed in the past, is of doubtful value.

MUMPS (EPIDEMIC PAROTITIS)

This not-so-contagious viral disease is characterized by painful swelling of the salivary glands (especially the parotids) and, frequently, by CNS involvement. An overwhelming majority of sufferers (85%) belong to pediatric age group. A single attack leads to life-long immunity.

Epidemiology

Mumps has a worldwide spread, the incidence being much higher in cities than in rural areas. Peak incidence occurs in late winter and spring. About 30 to 40% infections are subclinical.

Clinical Features

Mumps has an incubation period of around 17 days, the extremes being 12 to 24 days.

Prodromal phase is short (1 to 2 days) and is characterized by fever, malaise, sore throat, earache and pain behind the ear on chewing or swallowing.

Tender edematous swelling of parotid (unilateral or bilateral), without involving the submaxillary and sublingual salivary glands, in the subsequent 1 to 3 days, is the most important development. The enlarged gland displaces the ear-lobe upwards and outwards. Tenderness and pain subside in 1 to 3 days but it takes 7 to 10 days for the swelling to begin to regress. By this time, fever, anorexia, headache and malaise also disappear. At times, other glands like, submaxillary and sublingual may also be enlarged. In 10 to 15% cases, only submandibular glands are be enlarged.

The opening of the parotid duct, opposite upper second molar, is puffy and red.

One-half of the cases have an asymptomatic CNS involvement.

Differential Diagnosis

Differential diagnosis is from

1. Other causes of parotid swelling
 - Suppurative parotitis

- Recurrent parotitis secondary to allergy or calculus in Stensen's duct
 - Parotitis from HIV, coxsackie A, cytomegalovirus, choriomeningitis, etc in immunocompromised children
2. Lymphadenitis involving preauricular or anterior cervical glands.

Diagnosis

In the presence of bilateral tender swelling of parotids, especially when reinforced by history of exposure to mumps, diagnosis is clear.

When clinical diagnosis requires laboratory confirmation, the following investigations may be done:

- Complement-fixation test.
- CSF: High pressure, raised proteins and cells (mostly monocytes).
- Blood counts reveal leukopenia with lymphocytosis.

The first two are of particular value in recognizing mumps meningoencephalitis.

Mumps requires to be differentiated from cervical lymphadenitis. *Mikulicz disease* (an uncommon condition characterized by involvement of both parotids and lacrimal glands, absence of tears and dryness of mouth), mixed parotid tumor, stone in parotids duct, recurrent parotitis or sarcoidosis, may occasionally need to be excluded.

Complications

Mumps during first trimester of pregnancy may cause intrauterine death, endocardial fibroelastosis and LBW (Table 18.3).

Treatment

There is no specific therapy for mumps.

General measures are entirely symptomatic and include isolation, rest, antipyretics, local warm or cold applications, saline mouth wash, and, preferably, fluid diet during the initial stages of difficulty in chewing and swallowing.

The complications need to be tackled as per the individual merits of each. Many authorities favor the use of corticosteroids in the presence of orchitis.

Table 18.3: Complications of mumps

- *Orchitis-epididymitis*: Quite common and may cause unbearable pain. Its ultimate outcome may be testicular atrophy that can rarely cause sterility. In postpubescent girls, oophoritis may occur.
- Pancreatitis is uncommon and shows full recovery in 4 to 7 days.
- Meningoencephalitis, which may precede, accompany or follow mumps, occurs in about 10% of the cases. It is a serious complication and can prove fatal.
- Myocarditis, pericarditis, etc.
- Nephritis
- Hepatitis
- Thyroiditis
- Mastitis
- Arthritis
- Deafness due to neuritis of auditory nerve
- Facial palsy
- Ocular: Dacryoadenitis, optic neuritis, uveokeratitis, paresis,
- Thrombocytopenic purpura.

Prophylaxis

Active immunization is given in the form of MMR at 15-18 months (Chapter 10). Some experts do not favor vaccination against mumps. They feel that there is no need for its prevention. Immunization, they argue, may postpone the infection to later age when the disease often runs a severe course.

Passive protection can be given by convalescent gammaglobulin in a dose of 2.5 ml intramuscularly as soon as possible after exposure.

Prognosis

It is generally good. Most of the children with meningoencephalitis also show complete recovery. Some residual deafness may, however, remain in an occasional case.

POLIOMYELITIS

An acute viral infection (RNA enterovirus), characterized by clinical manifestations varying from *nil* to rapid paralysis and even death. The disease occurs exclusively in humans.

Etiopathogenesis

The etiologic factor is a RNA enterovirus* called *poliovirus*. One or more of its 3 stains** are responsible for the disease.

Transmission is mainly by oropharyngeal route. Multiplication occurs in gastrointestinal tract, related lymph nodes and reticuloendothelial system. Then, there is viremia of short duration. If the antibody formation fails to neutralize virus particles, there results proliferation of the virus and invasion of the nerve structure. Anterior horn cells, bulbar nuclei and cerebellar cortex are primarily affected.

Clinical picture depends on the number and location of involved neurons. The whole of CNS may be involved, except:

1. Entire cerebral cortex, minus motor area
2. Cerebellum, except vermis and deep midline nuclei
3. White matter of spinal cord.

The damage may, however, revert in 3 to 4 weeks after onset.

Epidemiology

Poliomyelitis has worldwide prevalence. The incidence was particularly high in regions where, the vaccination status (with regard to polio vaccine) of the community is poor.

In India, both epidemic and sporadic cases were seen, the latter throughout the year. Summer and autumn months are the epidemic periods with the peak incidence in August.

Incidence of poliomyelitis was much higher among nonimmunized city-dwellers than among the villagers.

A great majority of the paralytic cases occurred below the age of 3 years with the peak incidence at 2 years. It was uncommon after the age of 3 years by which time there is production of sufficient antibodies in blood. Neonatal poliomyelitis, though rare, is recorded in cases of infants born to nonimmune mothers.

Clinical Features

The incubation period is 7 to 14 days (range 5-35 days). The following clinical types are known:

- i. Asymptomatic (silent)
- ii. Abortive
- iii. Nonparalytic
- iv. Paralytic which may be spinal, bulbar, bulbospinal or encephalitic, depending on the location of the lesions.

Asymptomatic (silent, inapparent) polio In 90-95% of the susceptible persons infected with the virus, the infection is asymptomatic.

Abortive Here the virus has invaded the blood stream, thus causing a sort of *viremia*. The nervous system is, however, spared. Such subjects have influenza-like manifestations with bodily pains, fever, sore throat, anorexia, etc.

Nonparalytic polio The poliovirus has entered the nervous system without destroying the cells. The febrile illness (secondary to viremia) is, therefore, followed by meningeal irritation manifested in the form of neck stiffness, headache, pain in neck and back muscles, vomiting, etc. No paralysis occurs in this variety. Lumbar puncture can assist in arriving at the diagnosis but is best avoided.* The neck and back stiffness can be demonstrated by the *kiss-the-knee*** and *tripod signs****. It needs to be emphasized that the patient with nonparalytic polio remains entirely conscious despite the signs and symptoms simulating meningitis.

Paralytic Polio

- i *Spinal form*, involving the extremities, neck, abdomen, diaphragm and intercostals, is the commonest in clinical practice. Its major manifestations are:
 - a. Fever and other constitutional symptoms,
 - b. Muscle pain and tenderness in a large proportion of cases (not all),
 - c. Flaccid paralysis which is patchy and of lower motor neuron type (involvement of anterior

* The procedure may cause development of paralysis.

** *Kiss-the-knee* sign consists in directing the child to sit up and kiss his knee. The test is positive if he fails to do so without bending the knee. This is owing to the nuchal rigidity.

*** *Tripod sign* is elicited by asking the child to sit up. The test is positive if he assumes a tripod position while doing so

* ECHO (enteric cytopathogenic human orphan) virus and coxsackie (after a village near New York) virus are the other two enteroviruses.

** Type 1 (Burnside) causes large epidemics, type 2 (Lansing) isolated cases and small outbreaks, and type 3 (Leon) small epidemics

horn cells). Lower limbs are more often affected than upper limbs. Secondly, large muscles are more often involved than small muscles. Table 18.1 gives the frequency of muscle involvement. Maximum paralysis occurs on second to third day. There is absolutely no sensory loss. The characteristic position of a young child with paralytic polio (spinal) is depicted in Figure 18.8. The bulge produced as a result of weakness of the abdominal wall muscles when the child cries is termed *phantom hernia* (Fig. 18.9) which is a valuable sign.

- d. Bladder and bowel involvements are common. Whereas bladder involvement is of short duration (1 to 3 days), bowel involvement may lead to severe constipation that becomes quite troublesome for some days.
- ii. *Bulbar form* is relatively less often seen but is most severe because of involvement of vital medullary centers. It is characterized by paralysis of muscles supplied by cranial nerves (dysphagia, nasal speech and dyspnea due to involvement of soft palate and pharynx and facial paralysis) and vital respiratory and circulatory centers. Mild hypertension may also accompany.
- iii. *Bulbospinal form* is the combination of both spinal and bulbar forms and is encountered in about 25% cases of paralytic polio.



Fig. 18.8: Paralytic polio of both legs. Note the characteristic "frog" position



Fig. 18.9: Phantom hernia in poliomyelitis. Note the bulge in the abdominal wall

- iv. *Encephalitic form* is relatively uncommon. Besides other manifestations, some change in sensorium (irritability, drowsiness or even unconsciousness) is invariably present. It may well occur as an isolated entity or on top of bulbar or spinal forms. As a rule, poliomyelitis continues to progress in the acute phase (roughly when the child is febrile) until it reaches its peak. Then it begins to show signs of recovery which occurs maximally in the first few weeks. There-after, recovery slows down during the next 6 months. Recovery may still continue at a much slower pace up to 2 years (Table 18.4).

Table 18.4: Frequency of muscle involvement in poliomyelitis

Lower limbs

Quadriceps > Tibialis anterior > Peroneal muscles

Upper Limbs

Deltoid > Biceps > Triceps

Trunk

Abdominal muscles > Back muscles > Intercostals > Diaphragm

Most of the deaths in poliomyelitis occur from respiratory failure due to involvement of the vital center in bulbar form, or from severe paralysis of diaphragm and intercostal muscles.

Respiratory distress of polio is a serious problem and results from one or more of the factors given in Table 18.5.

Table 18.5: Factors contributing to respiratory distress in acute poliomyelitis

- Paralysis of the diaphragm manifested as paradoxical movements of the abdomen. This can also be confirmed by screening of the chest.
- Paralysis of intercostal muscles manifested by high respiratory rate, difficulty in vocalizing and anxious look. A cooperative child is unable to count to 40 after one inspiration. The capacity for thoracic respiration can be demonstrated by splinting the abdomen to exaggerate the chest movements.
- Involvement of medullary respiratory center.
- Involvement of vagus nerve nucleus leading to spasm or paralysis of vocal cords.
- Obstruction of upper respiratory passage due to collection of secretions/saliva, consequent to paralysis of certain nerves (9th, 10th, 11th and 12th).
- Local lung conditions such as pneumonia, collapse and pulmonary edema may also aggravate the respiratory difficulty.

Complications

Gastrointestinal: Bleeding, perforation, dilatation.

Cardiovascular: Hypertension, tachycardia, congestive cardiac failure, myocarditis, cardiac arrest.

Pulmonary: Respiratory distress, pneumonia, collapse, pulmonary edema.

Urinary tract: Transient paralysis of bladder, calculi, infection.

Diagnosis

In a large majority of the cases, diagnosis of paralytic polio is clear from the clinical profile. An acute onset of asymmetrical flaccid paralysis must arouse a suspicion of poliomyelitis.

Differential diagnosis is usually from pseudo-paralysis (scurvy, acute osteomyelitis, trauma, etc), meningitis, encephalitis, meningismus, and post-diphtheretic paralysis (Table 18.6).

At times, greatest difficulty arises in distinguishing polio from *Guillain-Barré syndrome*. The latter is characterized by symmetrical ascending paralysis, with some sensory loss, in majority of the instances. Moreover, there is typical *cytoalbuminous dissociation** in the CSF.

Lumbar puncture may be of marginal help in arriving at the diagnosis. It should, however, be

* Cells only slightly increased whereas proteins are disproportionately high. Similar picture may occur in CSF block. In aseptic meningitis, the picture is reversed

Table 18.6: Differential diagnosis of poliomyelitis

<i>Pseudoparalysis</i>	<i>Neurologic conditions</i>
Acute osteomyelitis	Guillain-Barré syndrome (GBS)
Septic arthritis	Transverse myelitis
Periostitis	Traumatic neuritis
Sprain	Postdiphtheretic paralysis
Syphilis	CNS infection (meningitis, encephalitis)
Scurvy	Botulism
Trichinosis	
Rheumatic fever	
Severe hypokalemia	

avoided as far as possible in view of the risk involved.

Isolation of the poliovirus from the stools and throat swab or demonstration of many-fold increase in the antibody titer in paired sera taken 2 weeks apart is the most reliable diagnostic armamentarium.

Treatment

There is no specific treatment available to date. General measures include:

- Hospitalization of all cases of paralytic polio
- Strict bed rest
- Minimal handling of the affected parts. *Neutral position* of the limbs is the best, i.e. knees little flexed, hips straight and shoulders abducted at right angles. In the event of involvement of the feet, these should be kept at right angles to the legs with the support of foot-boards, sand bags or light splint-shells. A relatively hard bed is preferred.
- Analgesics and mild sedation for relief of pain and restlessness. Dry heat with infrared lamp, hot packs or hot-tub baths are also of value.
- Attention to solving problems like retention of urine and constipation by simple measures.
- Maintenance of adequate fluid and dietetic intake.
- Suction to remove secretions from throat.
- A close watch for any respiratory distress. In case of involvement of diaphragm and intercostals, the child is best treated in a respirator. Positioning to avoid aspiration of the secretions is important. Tracheostomy may be required when there is constriction of the hypopharynx (*rope sign*) or paralysis of vocal cords. Ventilatory support and antihypertensive therapy may be warranted in some cases.

When the child is free from muscle pain and muscle spasm, physiotherapy should be started. To begin with, passive physiotherapy in the form of full range of movements within tolerance (pain) limits for 10 minutes, 2-3 times day, is recommended. Two weeks after the attack, active physiotherapy should be started.

Some children may require corrective splints, braces plus other devices. In a few, surgical intervention may be warranted at a later stage.

Prophylaxis

Active immunization is discussed in Chapter 10.

During epidemics, the following should be kept in mind:

- i. Avoid all provoking factors, e.g. overexertion and chilling, injections (including DPT) and tonsillectomy operations.

Provocative poliomyelitis may occur in the form of preferential paralysis in a limb when injection is given during the incubation period. The injection into the muscle is believed to cause hyperemia of the spinal cord, enabling the circulating virus to settle down.

- ii. Children should remain away from crowded places and swimming pools.

Pulse immunization In order to eradicate wild poliovirus from the community and environments, vaccination of the entire child population of the area in one single day (in addition to the routine vaccination) is required to be given. This is termed "pulse immunization". Such a mass immunization, given twice a year for 3 consecutive years, successfully eradicated poliomyelitis from Brazil. Since 1995, the Government of India has initiated pulse polio immunization (PPI) to achieve polio eradication from the country. The strategy provides two additional doses of OPV (independent of routine OPV immunization) to all children under 5 years on two single days at 6 to 8 weeks interval in the length and breadth of the country. The two PPI days or National Immunization days are chosen during low transmission season of poliovirus, usually in winter. The successful conduction of the program shows that India has the capacity to immunize 120 million preschool children on a single day. Table 18.7 gives the 4-pronged strategy for total eradication of polio. India has now entered the third and fourth stages in its quest for a final attack to totally get rid of poliomyelitis.

Unfortunately, the polio eradication program in India has suffered a setback because of recent occurrence of many fresh cases in UP and Bihar.

Table 18.7: Four-pronged strategy for total eradication of polio globally

- High routine immunization coverage with OPV
- Supplementary immunization in the form of pulse immunization program or an alternative strategy
- Effective surveillance system
- Final stage comprising mopping up by door to door immunization campaign.

Prognosis

The mortality is around 5 to 7%. The course of the disease among survivors too is variable from complete recovery to complete paralysis. Most of the cases fall somewhere inbetween.

Residual deformities in the form of *postpolio residual paralysis* (PPRP) (Fig. 18.10) include (a) wasted flail limb, (b) genu recurvatum, and (c) valgus foot. Deformities are far more frequent in distal joints of limbs. In foot and ankle, uniaxial rather than biaxial deformities are common.

GUILLAIN-BARRÉ SYNDROME (GBS)

Refer Chapter 23 (Pediatric Neurology).



Fig. 18.10: Postpolio residual deformities (PPRD). Note the wasted right lower limb with genu recurvatum

ACUTE FLACCID PARALYSIS (AFP) SURVEILLANCE

The term, *acute flaccid paralysis (AFP)*, means paralysis is acute in onset and the involved limbs are flaccid (floppy or limp).

Poliomyelitis is the most important cause of AFP in children. The nonpolio causes of AFP include Guillain-Barré syndrome (GBS), transverse myelitis (TM) and traumatic neuritis (TN).

AFP surveillance aims at detecting cases of AFP (under 15 years age) and reporting them immediately to the District Immunization Officer of the area. This should not be interpreted as meaning that only cases of polio are to be reported. All types of AFP cases require to be reported. Expected nonpolio AFP rate is > 1 in 100,000 children under 15 years of age in a year ("background rate" formed by GBS, TM and TN).

Special Features

1. *Reverse Cold Chain*: Stool samples (two, at least 24 hrs apart, within 14 days of onset of paralysis) from each AFP case are obtained and transported to the laboratory within 72 hours of collection (at 4-8°C or frozen at minus 20°C) for virological identification and, if found to be poliovirus, for finding whether it is a natural wild virus or vaccine-related virus.
2. *Outbreak Response Efforts*: These should be initiated promptly without waiting for the stool culture reports which may take 4 to 8 weeks.

All cases labeled as "discarded, not polio" require thorough justification and should be reported with final diagnosis.

Indicators of Quality

1. Nonpolio AFP rate > 1 in 100,000 children under 15 years (annual)
2. At least 80% of AFP cases whose two adequate stool samples have been examined.

Role

- To identify high-risk areas or groups where polio virus transmission is occurring or is likely to occur;
- To monitor progress so as to determine whether strategies are implemented effectively.
- To certify a country poliofree when no reports of new cases of polio are received for 3 consecutive

years; and that the country can detect a case of paralytic polio should it occur through importation. Also see Chapter 10.

Mopping up denotes the final strategy when door to door polio immunization is provided in high risk districts i.e. where polio cases are detected in the preceding 3 years.

INFECTIOUS MONONUCLEOSIS

This viral infection of the lymphatic system is characterized by fever, malaise, sore throat, maculopapular rash, lymphadenopathy, hepatosplenomegaly, atypical lymphocytes in peripheral blood and a heterophil antibody response.

Etiopathogenesis

The causative agent is Epstein-Barr virus of the herpes group. EB virus replicates in B lymphocytes. Nevertheless, most of the atypical lymphocytes in this disease are T lymphocytes.

Transmission of infection occurs by intimate contact, say during kissing by young adults or by exchange of saliva from child to child. Parotid gland of the patient may remain source of the virus, not only before and during clinical disease but even several months after.

Clinical Features

Incubation period is 30 to 50 days or perhaps less.

Onset is usually insidious with fever, malaise, fatigue, headache, and sore throat from pharyngitis and tonsillitis. After a week or two, generalized lymphadenopathy and hepatosplenomegaly become apparent. Enlargement of the posterior cervical nodes and epitrochlear nodes is characteristic. Stomatitis with petechiae at junction of hard and soft palate is frequent. An icteric hepatitis is quite common but frank jaundice is infrequent. Rashes and edema of eyelids may occur.

A maculopapular rash appearing after administration of ampicillin is a characteristic phenomenon.

Occasionally, the child may present with clinical picture suggesting aseptic meningoencephalitis.

The disease is self-limiting, the severe manifestations lasting 2 to 4 weeks followed by gradual recovery.

The term, *chronic mononucleosis syndrome*, refers to persistent EBV infection resulting in a "chronic fatigue

syndrome". It is characterized by an illness starting as infectious mononucleosis and lasting 6 months or more, abnormal EBV antibody profiles, and organic involvement in the form of lymphadenopathy, interstitial pneumonia, hepatitis, splenomegaly or bone marrow hypoplasia. The illness usually affects adolescents (and adults). Similar chronic fatigue syndrome may be caused by HTLV-II, CMV, HHV-6 and some unidentified retroviruses.

Complications

- Splenic rupture, usually in the second week, following trauma (as minor as palpation by a doctor).
- Respiratory obstruction due to massive swelling of tonsils and pharynx may be severe enough to warrant tracheostomy, or, if the condition is duly anticipated, steroids
- Neurologic involvement in the form of convulsions, ataxia and neck stiffness suggesting meningitis, transverse myelitis. Bell palsy, encephalitis, Guillain-Barré syndrome and Alice-in-Wonderland syndrome (meaning perceptual distortion of space and size)
- Myocarditis
- Interstitial pneumonia
- Hepatitis; even Reye syndrome.
- Hematogenous involvement in the form of hemolytic anemia, thrombocytopenia, aplastic anemia
- Pancreatitis
- Parotitis
- Orchitis.

Diagnosis

Clinical diagnosis may be corroborated by the following investigations:

- i. *Leukocytosis* of 10,000 to 20,000 cells/cmm; at least 2/3rd of these are lymphocytes. "atypical lymphocytes" (large with irregular shape, pale blue vacuolated cytoplasm and eccentric nucleus) form 20 to 40% of the total lymphocytes.
- ii. *Serologic tests for heterophil antibodies* include Paul-Bunnell test and Monospot test. *Paul-Bunnell test* is based on the observation that numerous abnormal antibodies are found in individuals with this disease. Antibody titer to sheep red cells exceeding 1:28 or 1:40 after absorption with guinea pig cells is regarded positive.

Monospot test is quicker, easier and more sensitive and specific than the Paul-Bunnell test.

Differential Diagnosis

Infectious mononucleosis with negative heterophil tests need to be differentiated from CMV infection, toxoplasmosis, acute HIV infection and infectious hepatitis (hepatitis A). Serological tests are helpful in arriving at the exact diagnosis.

Occasionally, differentiation may be warranted from streptococcal sore throat ("strep throat"), rubella, mumps, and adenoviral disease.

Atypical lymphocytosis may necessitate differentiation from CMV infection, infectious hepatitis, toxoplasmosis, typhoid fever, tuberculosis, malaria and mycoplasma infections.

Leukemia becomes an important differential diagnosis when a supposedly infectious mononucleosis patient shows low TLC, moderate thrombocytopenia and hemolytic anemia. Bone marrow is mandatory in this situation.

Treatment

Treatment is supportive and symptomatic. Steroids may be indicated in the following special situations:

1. *Short-term*: Pharyngotonsillar edema threatening airway obstruction, hepatitis, abdominal pain due to splenomegaly or lymphadenopathy.
2. *Long-term*: Hemolytic anemia, Guillain-Barré syndrome.

The antiviral drug, acyclovir, is of doubtful value in acute infectious mononucleosis. It is, however, beneficial in chronic infectious mononucleosis (as also in EBV-associated polyclonal lymphoproliferation).

Prognosis

In the absence of serious complications, prognosis is uniformly good and the patients eventually recover fully. Following acute illness, fatigue for months (chronic fatigue syndrome described in Chapter 42: Miscellaneous and Unclassified Issues) as also recrudescence during the first year is usual.

DENGUE FEVER

A viral disease of public health importance, dengue fever has been endemic all over India (Kashmir and Himalayan belt is exception) since 1963 with periodic extensive epidemics.

Etiopathogenesis

The causative virus has 4 antigenic types 1, 2, 3 and 4, belonging to the genus, *flavivirus*, each producing a similar illness. In our country, all the four types are prevalent.

The principle vector involved in transmission of the virus is the mosquito, *Aedes aegypti* (dominant in India) and *Aedes albopictus*. Clinical illness begins after a period of 5 to 6 days (variation 3 to 15 days) of the bite preceded a day before by viremia which continues till 4 to 5 days subsequent to the onset of clinical illness. During the course of viremia, the mosquito can get infected following a blood meal on an infected individual. It becomes capable of transmitting the disease to other individuals 8 to 14 days after the blood meal and remains infective all through its life.

Remember that spread of dengue fever is through the movement of the patient from place to place rather than that of the vector.

Clinical Features

Incubation period is 5 to 6 days with a variation of 3 to 15 days.

Manifestations include sudden onset of moderate to high fever, headache, retroorbital pain, muscle, bone and joint pains, anorexia, bad taste in the mouth, and flushing of face. In fair-skinned individuals, a maculopapular rash may be seen over the trunk and upper limbs 3 to 4 days after the onset of fever, lasting from a few hours to a few days. Often, the fever is biphasic. Convulsions along with tonsillitis, pharyngitis, rhinitis, or diarrhea are encountered in some children. Hemorrhagic manifestations are infrequent.

Positive physical findings may include cervical lymphadenopathy (rarely generalized lymphadenopathy), hepatosplenomegaly and relative or absolute bradycardia.

Recovery, with regression of fever by lysis and profuse sweating in 2 to 7 days, is relatively faster in children. Convalescence is marked by generalized weakness.

Dengue hemorrhagic fever (DHF)/dengue shock syndrome (DSS), a severe, often fatal, form of the disease, is almost exclusively limited to children in some South-East Asian countries (including India). It is believed to be a hypersensitivity response to a

repeat attack with the dengue fever virus. Clinical picture is dominated by fever, hemorrhage and shock. Though hemorrhagic manifestations are usually cutaneous, in the epidemic of DHF/DSS seen by us during fall and autumn of 1993 at Jammu, gastrointestinal hemorrhages dominated the scene. Table 18.8 gives its grading.

Table 18.8: WHO grading of dengue hemorrhagic fever (DHF)

Grade 1:	Fever, nonspecific constitutional symptoms, positive Hess (tourniquet) test.
Grade 2:	Features of grade 1 + spontaneous bleeding into the skin and/or from other sites.
Grade 3:	Circulatory failure manifested by rapid weak pulse, hypotension or low pulse pressure, cold, clammy skin, restlessness.
Grade 4:	Profound shock manifested by unrecordable BP and pulse.

Diagnosis

Clinical picture of dengue fever is supported by a positive Hess test, raised hematocrit (20 percent above baseline), leukopenia with relative lymphocytosis, reduced platelet count and increase in immature or unsegmented polymorphonuclear cells.

Serology and virus isolation, though ideal, are time-consuming. IgM antibody estimation, mosquito inoculation and indirect immunofluorescent test also give early results.

Differential Diagnosis

During epidemics of dengue fever, there is little difficulty in diagnosing the disease. Otherwise, a large number of conditions, including chickungunya fever, leptospirosis, meningococemia, enteric fever, influenza, and malaria need to be considered in the differential diagnosis. In the event of hemorrhagic manifestations, meningococemia, scrub typhus and leptospirosis become important differential diagnosis.

Kyasanur forest disease, yellow fever and hemorrhagic fever with renal syndrome may also need to be borne in mind in certain regions.

Complications

These include fluid and electrolyte imbalance, hyperpyrexia, shock, and febrile seizures.

Treatment

There is no specific treatment whatsoever for dengue fever. Management is more or less supportive and consists in controlling the high fever with hydrotherapy/antipyretics, relieving pains with analgesics, maintenance of fluid and electrolyte balance and nutrition, and monitoring of the vital signs and fresh blood transfusion in case of accompanying bleeding manifestations. Drugs that may precipitate hemorrhage (say aspirin) should be avoided.

In established thrombocytopenia, transfusion of a platelet concentrate, 10 ml/kg, to raise the platelet count to above 50 thousand/cmm, is strongly recommended. The concentrate can be prepared either by centrifugation of fresh whole blood or by automated platelet pheresis. Multiple platelet transfusion may lead to platelet refractoriness. Hence, multiple platelet transfusion must employ filtered (leukocyte-reduced) platelet concentrates. Moreover, platelet concentrates must be infused within 2 hours (max.).

Prevention

For prevention and control of dengue fever, a wholesale attack on the vector mosquito (*Aedes aegypti*) population and personal protective measures are needed.

A killed vaccine for dengue fever, though effective in prophylaxis, is not easily available. Attenuated dengue types 1, 2 and 4 vaccines are being developed in Thailand. A possible risk of dengue vaccination is sensitization of the recipient, resulting in dengue hemorrhagic fever after a subsequent dengue infection.

Prognosis

Dengue fever is usually self-limited and benign. If complications are prevented or handled well, full recovery is a rule.

In dengue hemorrhagic fever, mortality is around 40 to 50%. Energetic and intensive care should bring down mortality to as low as 2%.

CHIKUNGUNYA FEVER

Etiology

The etiologic agent is chikungunya virus which is transmitted by mosquitoes, *Aedes*, *Culex* and

Manssonia. It was in 1952-53 that this virus was first isolated in Tanzania from patients and mosquitoes.

Epidemiology

Two outbreaks of chikungunya, in Kolkata in 1963-64 and in Chennai in 1965 are on record. Having remained dormant for three decades, the virus has become active in recent years, giving rise to hundreds of cases of chikungunya in south India in particular.

Clinical Features

Clinical presentation is like dengue fever with pyrexia and severe joint pains which may cause "doubling up of the body."

Treatment

It is by and large supportive.

Prevention and Control

Vector control

It is targeted at *Aedes aegypti* mosquito and comprises keeping breeding places of mosquitoes such as water containers and air coolers free of mosquitoes and use of insecticides and aerosol of ultra-low volumes of malathion or sumithion.

Vaccination

A suitable vaccine is not yet available.

JAPANESE ENCEPHALITIS

Etiology

Primarily a zoonotic disease, JE is a mosquito-borne encephalitis caused by group B arbovirus (Flavivirus) and transmitted by bite of culicine mosquitoes (Vector of JE).

Clinical Features

Incubation period is 5-15 days. A large majority of the case have an inapparent infection.

Full-blown disease shows 3 stages:

Prodromal stage is characterized by fever, headache and malaise, lasting for 1-6 days.

Acute encephalitic stage is characterized by high fever, neck rigidity, seizures, change in sensorium (even coma) and focal neurologic signs.

Late Stage (sequelae) is characterized by resolution of active inflammation (resulting in control of fever, and ESR reverting to normal), CNS signs becoming stationary or showing improvement. Residual neurologic deficit (sequelae) may be left.

Management

It is by and large supportive.

Prognosis

Mortality is high, usually varying from 20 to 40%. On an average, death occurs after 7 days of onset of disease.

Prevention/Control

- A. Vector control
 - Mosquito nets
 - Aerial/ground fogging with fenitrothion or malathion
- B. Vaccination
 - See Chapter 10 (Immunization).

VIRAL HEPATITIS

On the basis of viral, immunologic and epidemiologic studies, at least 5 forms of viral hepatitis stand well recognized, namely hepatitis A, hepatitis B, hepatitis C, hepatitis D and hepatitis E. Hepatitis A, C, D and E are RNA virus whereas hepatitis B is a DNA virus. In addition, hepatitis F and G are in the process of exploration and there are several nonhepatotropic viruses like CMV, EBV, HS, varicella zoster, HIV, mumps, adenovirus and ECHO virus that involve the liver. For details, see Chapter 25 (Pediatric Hepatology).

SLOW VIRUS INFECTION

Certain viruses remain dormant over years but may flare up later at periods of debility and vulnerability. The very long incubation period and a slow course, terminating fatally, has earned them the name "slow virus infections or disease". The other characteristics include (a) the course marked by remissions and exacerbations, (b) predilection for CNS, (c) absence

or abnormal immune response, and (d) a genetic predisposition. Three groups of the diseases are recognized: (i) Group A: *Vinsna and maedi*, demyelinating disease and progressive hemorrhagic pneumonia respectively, caused by closely-related leukoviruses in sheep. (ii) Group B: Subacute spongiform viral encephalopathy and Creutzfeldt-Jakob disease. (iii) Group C: Subacute sclerosing panencephalitis (SSPE) which is a delayed sequel to measles virus or live measles vaccine, and progressive multifocal leukoencephalopathy which occurs in elderly persons with impaired immune response due to malignancy or immunosuppressive therapy. Recently, it has been suggested that slow virus infection may be classified as (i) those caused by conventional viruses and (ii) those caused by unconventional viruses (Table 18.9). The first group refers to viruses with conventional physical properties and with manifestations of acute self-limited illness. In the second group are agents that have physical properties very much different from conventional viruses but that are much smaller than bacteria.

It is possible that slow virus infections are responsible for many more degenerative and other disorders. As for instance, slow ECHO virus has been incriminated in the etiology of Guillain-Barré syndrome.

HYDROPHOBIA (RABIES)

This fatal viral infection of the central nervous system results from contamination of a wound with saliva from a rabid warm-blooded animal, in India and other tropical countries usually a stray dog.

Table 18.9: Two groups of slow virus infections

Conventional

- Subacute sclerosing panencephalitis (SSPE)
- Progressive rubella panencephalitis (PRP)
- AIDS encephalopathy
- Rabies
- Cytomegalovirus (CMV) encephalitis
- Kozhevnikov's epilepsy
- Tropical spastic paraparesis (TSP)/HTLV-I-associated myelopathy (HAM)
- Progressive multifocal leukoencephalitis (PML)
- (?) Rasmussen chronic encephalitis

Unconventional

- Kuru
- Creutzfeldt-Jakob disease (CJD)
- Gerstmann-Straussler syndrome (GSS)

Rabies virus, belonging to a rhabdovirus group, reaches and multiplies first in striated muscle from the wound. If the protective host factors are insufficient, it attaches itself to the nerve. Thereafter, it ascends axons from the periphery to the spinal cord and eventually to the neurons in the brain.

The pathologic hallmark of rabies is the *Negri body* that is found in neurons.

Neuronal destruction in the brainstem and medulla with severest changes in the pons and the fourth ventricle is the basic lesion. The disease is a brainstem encephalitis with intact cortex and maintenance of sensorium.

Incubation period is 20 to 180 days with a peak at 30 to 60 days, the extreme being 9 days and 1 year.

During the prodromal phase of 2 to 10 days, non-specific manifestations like pyrexia, malaise, vomiting, anorexia, headache, anxiety, pain or paresthesia at the location of the wound occur.

Manifestations of acute neurologic phase include hydrophobia, aerophobia (violent spasm of pharynx and larynx; considered pathognomonic of rabies), bursts of hyperactivity, odd behavior, disorientation with periods of lucidity, utterly anxious look, hoarseness, dysphagia, pharyngeal pain, convulsions, and meningeal irritation.

Though a large majority of cases evince the above said “furious” variety, in some 20% cases the picture is of ascending symmetrical paralysis (“paralytic” variety).

Despite intensive treatment, including large dose of interferon and antirabic serum and supportive care, rabies proves invariably fatal. To date, only 3 cases are documented as surviving rabies. However, patients can be kept alive for some months with intensive management. Prevention of rabies is detailed in Chapter 10.

PEDIATRIC ACQUIRED IMMUNE DEFICIENCY SYNDROME (AIDS)

AIDS, aptly described as the “20th century plague”, and “worst among the most devastating diseases of the day”, is characterized by total collapse of the immune system of the body, rendering the subject acutely vulnerable to opportunistic infections that eventually prove fatal. Even a minor common cold may make the immunologically-knocked-down patient with AIDS lose his life.

AIDS is believed to have made a head start in Africa. Marching through the Caribbean islands, it entered the United States and from there to Europe. Now, AIDS has been reported from virtually all over the world. In Asia—Thailand, India, Japan, Hong Kong and Singapore figure prominently among the countries with its documented cases. Around 95% of the cases on record from S-E Asia are from Thailand and India.

Contrary to the earlier belief, AIDS does not spare children. According to conservative estimates, pediatric AIDS forms 2% of all AIDS cases in the West. In the developing world, pediatric AIDS comprises 15 to 20% of all cases. Unless preventive measures are taken on war-footing, it may wipe out the benefits brought about by the modern medicine in the foreseeable future.

Tables 18.10A and 18.10B provide estimates of AIDS and HIV infection data.

Table 18.10A: Global estimates of AIDS and HIV infection: Data at a glance

- 40 million people living with HIV / AIDS.
2.7 million children <15 years.
17.6 million women
- An estimated 14,000 people become HIV infected every day.
2000 children <15 years.
An estimated 3 million people die from AIDS-related causes every year.
- Leading cause of death in sub-Saharan Africa
- Fourth biggest killer worldwide
- Overwhelming majority of people with HIV (approximately 95% of the global total) live in developing world.

Table 18.10B: Indian estimate of AIDS and HIV infection: Data at a glance

- 27 million women are pregnant every year.
0.3% HIV Prevalence
1,35,000 pregnant women are at high-risk for HIV transmission.
- 85-90% HIV infection are due to blood/blood product transfusion, unsafe sex.
- 11,000 children die of AIDS every year.
- 120,000 affected orphan are living in the country at present.

Etiology

The cause is a retrovirus named human T-cell lymphotropic virus-III (HTLV-III) by Paris workers, and lymphadenopathy-associated retrovirus (ARV) by

San Francisco workers. The virus is now redesignated as human immunodeficiency virus (HIV-1).

The risk factors for acquiring the disease in adults include male homosexuality with multiple sex partners (the passive partner in anal intercourse in particular), intravenous drug abuse, Haitian origin, and hemophilia A with history of factor VIII concentrate therapy.

Infants born to mothers with risk factors can have AIDS transmitted to them. Risk factors for pediatric AIDS include

- Mothers who are addicted to intravenous drug(s).
- Mothers who indulge in prostitution
- Mothers who are heterosexual with bisexual husbands.
- A history of blood transfusion with blood or its products including factor VIII concentrates within the preceding 5 years.
- A history of residence in certain geographical areas that are inhabited considerably with AIDS patients.

Generally, AIDS in newborns is perinatally acquired though *in utero* as well as postnatal infection from breast milk can occur. A strong link has been documented between maternal vitamin A deficiency and vertical transmission of HIV, increasing the risk by 3 to 4 folds.

Pathogenesis

AIDS produces disturbance in all the four major components of the normal immune system, namely T-cells, B-cells, complement and phagocytic activity.

The most prominent effect is on the T-cells, resulting in reversal of helper/suppressor T-cell ratio (the normal being over 1.0) which tends to persist. With progression of the disease, such functional abnormalities of the T-cells as abnormal response of lymphocytes to antigens, mitogens and allogeneic cells and failure to produce normal amounts of interleukin-2, interferon and other lymphokines may result.

T-cell defect leads to defect in B-cell system, resulting in polyclonal hypergammaglobulinemia (raised IgA, IgG and IgM). Consequent upon this, the patient fails to form antibodies to antigens with which he has recently been immunized.

Increased amounts of circulating immune complexes due to chronic microbial infections is a rule. Some subjects show abnormal monocyte chemotaxis, antigen processing, and cytotoxicity.

Leading causes of mortality are opportunistic infections and Kaposi sarcoma and other malignancies.

Classical histologic feature of pediatric AIDS is widespread lymphoid infiltration of the lung, the so-called *diffuse lymphoid interstitial pneumonia*. Thymus and lymphoid tissue show histologic features of a chronic infection.

The entire tissue appears to be made up of cords and broad sinuses.

Clinical Features

Incubation period (time from exposure to the virus to the development of the disease) varies between 3 months to 5 years, depending on a pre-existing immunodeficiency such as prematurity or viral immunosuppression, or presence of other infections.

Manifestations in infants born to mothers with risk factors include small-for-dates, failure to thrive, microcephaly, hepatosplenomegaly, lymphadenopathy, chronic interstitial pneumonia—*Pneumocystis carinii* in particular recurrent otitis media, chronic sinopulmonary infection, oral candidiasis, chronic diarrhea and chronic parotid swelling. Kaposi's sarcoma is uncommon in pediatric AIDS.

Manifestations of transfusion-associated AIDS include *Pneumocystis carinii* pneumonia, Kaposi's sarcoma, chronic lymphadenopathy with recurrent pyrexia, night sweats, weight loss, chronic diarrhea, hepatosplenomegaly and evidence of other viral infections like Epstein-Barr (EB) virus, hepatitis B and cytomegalovirus.

Table 18.11 lists the clinical features of pediatric AIDS.

Diagnosis

The following factors, if present, are considered sufficient to reach the diagnosis of AIDS in infants and children.

A risk factor associated with AIDS

- Polyclonal hypergammaglobulinemia
- T-cell immunodeficiency

Table 18.11: Clinical features of pediatric AIDS

<i>Generalized (Nonspecific) Pyrexia</i>	
Failure to thrive	
Lymphadenopathy	
Recurrent infections	
Developmental delay	
LBW	
<i>Specific</i>	
Embryopathy	
Microcephaly	
Facial dysmorphism	
Hepatosplenomegaly	
Lymphocytic interstitial pneumonia	
Diarrhea	
Gastrointestinal bleeding	
Cardiomyopathy	
Arteriopathy	
Nephropathy	
Encephalopathy	
Parotitis	
Kaposi's sarcoma	
Rashes	
<i>Infections</i>	
<i>Pneumocystis carinii</i>	
<i>Cryptosporidium</i>	
<i>Cryptococcus</i>	
Moniliasis	
CMV	
EBV	
Herpes simplex (type 1 and 2)	
Varicella zoster	
<i>H. influenzae</i> (type B)	
<i>Pneumococcus</i>	
<i>Salmonella</i>	
<i>Shigella</i>	
<i>L. giardia</i>	
<i>Ent. histolytica</i>	

- Evidence of infection with human immunodeficiency virus (HIV)
Investigations suggested for a suspected case of AIDS are:
- TLC and DLC: Lymphopenia (under 2,000/ cmm) is a significant finding.
- Platelet count indicating thrombocytopenia
- Quantitative measurement of immunoglobulin levels to substantiate the raised levels of IgA, IgG and IgM.
- Demonstration of a reduced helper/suppressor T-cell ratio
- Circulating immunocomplexes
- Reduced IL-2 and interferon
- Reduced natural killer cells
- Lymph node biopsy

- ELISA test
- Western blot test
- Culture of the virus
- T cell growth factors.

If *Pneumocystis carinii* pneumonitis is suspected, demonstration of the causative organisms, *P. carinii* may be done on bronchoalveolar lavage, tracheal aspirate, transbronchial lung biopsy, bronchial brushings, percutaneous transthoracic needle aspiration, induced sputum samples, or open lung biopsy, the last-named being the most reliable method.

Table 18.12 gives diagnostic criteria of AIDS and Table 18.13 classification of HIV infection in children.

3

Table 18.12: World Health Organization (WHO) criteria for diagnosis of pediatric AIDS in developing countries such as India*Major Criteria*

- Weight loss or abnormally slow growth
- Chronic diarrhea for over 1 month
- Prolonged or intermittent pyrexia for over 1 month

Minor Criteria

- Generalized lymphadenopathy
- Oropharyngeal candidiasis
- Recurrent common bacterial infections
- Persistent cough for over 1 month
- Generalized dermatitis
- Confirmed HIV infection in the mother

Note: The existence of 2 major and 2 minor criteria in the absence of other known causes of immunodeficiency is diagnostic of AIDS

Table 18.13: Classification of HIV infection in children under 13 years as per the Center for Disease Control*Class P-O*

Intermediate infection in infants under 15 months of age (who are exposed to an infected mother) with antibodies to HIV.

*Class P-1**Asymptomatic infection*

- Subclass A: Normal immune function
- Subclass B: Abnormal immune function
- Subclass C: Immune function remains untested

*Class P-2**Symptomatic infection*

- Subclass A: Nonspecific findings
- Subclass B: Progressive neurologic disease
- Subclass C: Lymphocytic interstitial pneumonitis (LIP) established by chest X-ray or histopathologically.
- Subclass D: Secondary infectious diseases.
- Subclass E: Secondary malignancies
- Subclass F: Other diseases possibly due to HIV infection, including cardiomyopathy, hepatitis, nephropathy, hematologic and dermatologic disorders.

Prevention

The patients with risk factors associated with AIDS, especially the mothers, must be advised to appreciate that they or their offsprings may be heading for a potentially fatal disease and that they must change the lifestyle.

Reducing exposure to the offending virus is a must, say by instituting screening measures to exclude blood donors and, individuals with AIDS-associated risk factors. Attempts to inactivate retrovirus in factor VIII concentrate to cut down the risk of AIDS to hemophiliacs are in progress.

A desperate search for an effective AIDS vaccine is in progress.

Zidovudine is of value for decreasing perinatal transmission of HIV.

Box 18.2 gives a list of available antiretroviral drugs along with their dosage. Instead of the monotherapy, the current recommendation is for combination therapy, in the form of highly active antiretroviral therapy (HAART) which consists of a combination of two NRTIs and a protease inhibitor (Box 18.3).

Box 18.2: Antiretroviral drugs with pediatric dosage

<i>Nucleoside Reverse Transcriptase Inhibitors (RTI)</i>	
Zidovudine (ZDV, AZT)	90-180 mg/m ² 6-8 hrly
Lamivudine (3TC)	4 mg/kg BD
Didanosine (ddL)	90-150 mg/m ² 12 hrly
Stavudine (d4D)	1 mg/kg 12 hrly
Abacavir (ABC)	8 mg/kg 12 hrly
Zalcitabine(ddc)	0.005-0.01 mg/kg 8 hrly
<i>Non-nucleoside Reverse Transcriptase Inhibitors (RTI)</i>	
Nevirapine (nVP)	120-200 mg/m ² 12 hrly
Efavirenz (EFV)	200-600 mg qd
Delaviridine (DLV)	400 mg TDS (adolescents)
<i>Protease Inhibitors</i>	
Ritonavir (RTV)	400-450 mg/m ² 12 hrly
Nelfinavir (NFV)	30 mg/kg 8 hrly

Box 18.3: Highly active antiretroviral therapy (HAART)

<i>2 NRTI choices</i>	<i>Third drug (Protease inhibitor)</i>
ZDV + ddI	RTV/NFV (liquid formulation)
ZDV + 3TC	NFV/IDV/Saquinavir (tablet/capsule form)
D4T + ddI	
D4T + 3TC	

Note: HAART consists of a combination of 2 NRTIs and a protease inhibitor

Supportive measures, are needed, e.g. pentamidine and cotrimoxazole for *Pneumocystis carinii* infection, strong antifungal agents like ketoconazole and amphotericin B for chronic candidiasis, intravenous gammaglobulin, 100 to 200 mg/kg every month, for prevention of bacterial and viral infections, irradiation of all blood products to be transfused to prevent graft vs host reaction, and ensuring absence of antibodies against cytomegalovirus in them, avoidance of immunization, etc.

Use of bone marrow transplantation, thymic factors and interleukin for correcting the immunologic defects in AIDS has proved of no value.

Immunization of HIV Positive Children

Routine pediatric immunization must be given to the HIV infected infants and children with the following modifications:

- In case of asymptomatic cases, OPV, Pneumovax and *Hemophilus influenzae* vaccines be omitted.
- In case of symptomatic cases, OPV and BCG be omitted.

RESPIRATORY SYNCYTIAL VIRUS (RSV) INFECTION

RSV is a pneumovirus, a single-stranded RNA virus, with a lipid bilayer envelope that secretes a special protein, *transmembrane protein F* that contributes to formation of syncytia in the epithelial cells of the respiratory tract.

Contrary to the general belief that RSV infection is a problem of the West, WHO has shown that even in the developing countries RSV is the main cause of lower respiratory infection (LRI), killing around 600,000 infants and young children annually;

Recognized risk factors for development of severe RSV infection include prematurity, chronic lung disease, congenital heart disease, immune compromised state and age under 6 weeks.

Clinical problems resulting from RSV infection include acute bronchiolitis and viral pneumonia.

Diagnosis is usually clinical. Definitive diagnosis is by demonstration of the RSV or its antigen in the respiratory secretions, usually from posterior nasal cavity, nasopharynx or throat.

Prophylaxis in high-risk subjects is possible through RSV immune globulin (RSVIG) or a

humanized anti-RSV monoclonal antibody (Palivizumab). A suitable vaccine for use in infants and children, though urgently needed, is yet to be available.

The only recognized antiviral drug for RSV infection is ribavirin aerosol which should be administered early in the course of the disease in very sick or high-risk infants. Also see Chapter 20.

SEVERE ACUTE RESPIRATORY SYNDROME (SARS)

See Chapter 21 (Pediatric Pulmonology).

BIRD (AVIAN) FLU

Bird flu (avian influenza) is a contagious disease caused by certain viruses, usually in domestic poultry birds (chickens, ducks) and less frequently in pigs.

The highly pathogenic viral strain, H5N1, is capable of jumping the species barrier and cause severe disease in humans with high mortality. What is worse, the avian virus is capable of crossreacting with the human influenza virus, leading to genesis of a new virus which may cause severe influenza epidemics in humans. Human to human spread, though rare, is possible.

Antiviral drugs effective against the human infection are

- *M2 inhibitors*: Amantadine, rimantadine
- *Neuraminidase inhibitors*: Oseltamivir, zanamivir

Prophylaxis comprises destruction of infected birds/animals, avoidance of handling of infected birds, full cooking of the chicken, quarantine of the infected individuals.

FURTHER READING

Articles/Chapters

1. Anonymous. Chikungunya fever fact sheet. www.cdc.gov. Accessed on 6th June 2008.
2. Bhave SY, Jayakar AV. Pediatric AIDS. In Gupte S (Ed): *Recent Advances in Pediatrics*. New Delhi: Jaypee 1994;4:167.
3. Dutta AK, Aggarwal A. Dengue fever. In Gupte S (Ed): *Recent Advances in Pediatrics (Special-1: Tropical Pediatrics)*. New Delhi: Jaypee, 1998.
4. Lahariya C, Sharma AK, Pradhan SK. Avian flu and possible human pandemic. *Indian Pediatr* 2006;3:3:17-25.
5. Tiwari SK, Kale P. Pediatric HIV infection. In Gupte S (Ed): *Recent Advances in Pediatrics-16*. New Delhi: Jaypee 2006.
6. Verma. Japanese encephalitis. In Gupte S (Ed): *Recent Advances in Pediatrics (Special-18: Pediatric Neurology)*. New Delhi: Jaypee 2007.

Book/Monograph

1. Blunner JL, Toltitis. *Infections Disease Clinics of North America (Vol 19: Pediatric Infections Disease)* Philadelphia: Elsevier/Saunders 2005.



Pediatric Bacterial Infections

Karnail Singh, Suraj Gupte

HEMOPHILUS INFLUENZAE B (HIB) DISEASE

H. influenzae is a gram-negative pleomorphic coccobacillus normally present in the nasopharynx in unimmunized subjects. Typable *H. influenzae* are of six serotypes, types a to f.

Epidemiology

The most virulent strain, *H. influenzae type b*, is responsible for disease in 95 percent of the cases. Around 90 percent of the cases are aged less than 5 years, the vast majority belonging to infancy.

Mode of transmission is direct contact or a droplet infection.

Incubation period is variable.

Communicability is not defined.

Predisposing factors include:

- Population/ethnic groups: Blacks, Eskimos, Apaches, Novajos
- Diseases: Sickle-cell disease, asplenia, immunodeficiency states (both congenital and acquired), malignancy
- Previous history of a documented HIB disease.

Etiopathogenesis

H. influenzae type b causes invasive disease by entry into the intravascular compartment unlike nontypable organisms which cause problems by spread from nasopharynx to middle ear, sinuses and conjunctiva.

Clinical Features

Manifestations, depending on the type of invasive involvement, include meningitis, septicemia, epiglottitis, pneumonia, cellulitis, suppurative arthritis, pericarditis.

Remaining manifestations, more often from nontypable organisms, include invasive neonatal disease (septicemia, pneumonia, RD with shock, conjunctivitis, cellulitis, meningitis), otitis media and sinusitis.

Rarely, UTI, cervical adenitis, epididymoorchitis, glossitis, osteomyelitis, peritonitis, endocarditis and endophthalmitis may occur.

Diagnosis

It is by identification of *H. influenzae* in smears, by culture or by serotyping by slide agglutination with type-specific antisera.

Treatment

Initially, parenterally administered extended-spectrum cephalosporins such as cefotaxime and ceftriaxone should be employed because of their efficacy against ampicillin-resistant strains. Alternatively, chloramphenicol and ampicillin may be given.

Later, an appropriate antimicrobial is selected depending on the culture sensitivity report, ampicillin being the drug of choice in susceptible isolates. Therapy can be completed with oral antibiotics like amoxicillin-clavulanate combination, cefixime or cefpodoxime. Chloramphenicol is an economical and effective option.

Prevention

Hib conjugate vaccine (Chapter 10: Immunization) has played a remarkable role in drastically reducing HIB disease in the west and is strongly recommended in developing countries too. Chemoprophylaxis consists

of administration of rifampicin, 10 mg/kg (0) below 1 month and 20 mg/kg (0) above one month daily for 4 consecutive days, for the contacts as well as the index case.

PERTUSSIS (*Whooping Cough*)

Pertussis is a highly communicable bacterial infection characterized by catarrhal symptoms followed by bouts of cough which further worsen to *inspiratory whoop*. It is primarily a disease of preschoolers and may occur in a newborn even. Preschoolers are responsible for 50% of the total cases.

A single attack confers life-long immunity in a vast majority of the cases.

Etiopathogenesis

The causative organism is a nonmotile, rod-shaped Gram-negative bacillus, *Bordetella pertussis*, *Bordetella para-pertussis*, *Bordetella bronchiseptica*. *Hemophilus hemolyticus*, and adenovirus infection (types 1, 2, 3 and 5) may produce similar though mild disease.

Transmission is mostly by droplet infection and occasionally, by contact with contaminated objects. Infectivity remains from 1 week prior to and 3 weeks after onset of typical paroxysm.

Pathological involvement of the respiratory tract from nasopharynx to bronchioles, producing inflammatory reaction of the mucosa and secretions (phlegm) is responsible for most of the manifestations.

A number of antigens and toxins contribute to pathology and the resultant manifestations of pertussis (Table 19.1). Whereas most of these cause local pathology, pertussis toxin (PT) is primarily responsible for systemic manifestations.

Clinical Features

Whooping cough has an incubation period of 6 to 21 days with a mean of 7 days.

Three stages, each of about 2-week duration, are known.

Catarrhal stage Onset is usually insidious with catarrhal symptoms, i.e. rhinitis, sneezing, lacrimation, fever and irritating cough which is nocturnal to begin with but later becomes diurnal.

Paroxysmal (Spasmodic) stage Cough comes in paroxysms and is accompanied by vomiting. A typical attack consists of repeated series of many a cough-

Table 19.1: Major antigens and toxins responsible for pertussis pathology and symptom complex

Toxins	Mechanism of actions
<i>Major antigens</i>	
Filamentous hemagglutination	Attachment of the pathogens to the antigen (FHA) respiratory epithelium
Lymphocytosis promoting factor (LPF)	Absolute lymphocytosis
<i>Toxins</i>	
Adenylate cyclase toxin (ACT)	Inhibits phagocytic function
Dermonecrotic toxin (DNT)	Local epithelial damage
Pertussis toxin (PT)	Attachment of the pathogens to the respiratory epithelium; inhibits phagocytic function
Tracheal cytotoxin (TCT)	Disrupts mucociliary clearance; damage to the epithelium

in-expiration followed by a sudden, deep, violent inspiration with characteristic crowing sound which has earned the designation *whoop*. It is due to laryngospasm. The patient appears suffocated with congested (red) face, with or without cyanosis, and anxious look (Fig. 19.1). Sweating, congestion of neck and scalp veins, and confusion may follow the spells. Periorbital edema, subconjunctival hemorrhage, ulcer of frenulum of tongue, exhaustion, dehydration and convulsions may complicate the clinical picture.



Fig. 19.1: Pertussis. Note the facial appearance during a typical paroxysm. Such factors as eating, sudden movements and change in room temperature precipitate paroxysms

The paroxysm may be triggered by eating, yawning, sneezing, drinking, any other sudden movement, change in room temperature, and even by a suggestion.

Convalescent stage Here, disturbing cough and vomiting stop. Appetite too improves. The so-called "habit pattern" of coughing may, however, linger on over subsequent weeks and months. This has led the Chinese call it "cough of 100 days". Such lung complications as atelectasis, bronchopneumonia or bronchiectasis are known to significantly prolong the convalescence.

3

Diagnosis

It is easy to recognize a typical case, especially in the second stage. The disease should be differentiated from whoop produced as a result of pressure of enlarged paratracheal lymph nodes in tuberculosis and Hodgkin disease. It needs to be remembered that a pertussis-like syndrome may result from infection with *Bordetella parapertussis*, *Bordetella bronchiseptica*, *Hemophilus hemolyticus* and adenoviruses, and foreign body in the airway. As has been rightly put: **"Everyone producing a whoop does not necessarily suffer from whooping cough."**

The WBC count is initially low but then rises far beyond the normal, varying from 20 to 50 thousand/cmm. There is, however, **remarkably high absolute lymphocytosis**, always above 50% and frequently as high as 90%. This feature is quite suggestive of whooping cough.

The ESR is, however, extremely low. In fact the triad of *whoop*, lymphocytosis and low ESR strongly favors the diagnosis of this disease.

Chest X-ray may demonstrate perihilar infiltration, atelectasis or emphysema.

The only definite means of arriving at the diagnosis is the positive nasopharyngeal culture on *Bordet-Gengou medium* or *Regan-Lowe medium*. This is warranted in the first stage and in the atypical cases. In place of nasopharyngeal swab technique, the cough-plate method can also be employed.

For rapid diagnosis, fluorescent antibody test on the laryngeal swab, CIE and DNA probe are of value.

ELISA may be employed to detect serum IgM, IgG and IgA to filamentous hemagglutinin (FHA) and pertussis toxin.

The most sensitive and specific test for acute infection is IgG directed towards pertussis toxin.

Complications

The incidence of complications in pertussis is high (Table 19.2).

Treatment

General measures consist of isolation of the patient, sedation, cough sedatives, and liberal use of oxygen to reduce anoxia and brain damage in severe type of disease. Maintenance of fluid and dietary intake is important. Feeds should be small but frequent. The child tolerates the small feed better after the paroxysm.

Erythromycin (preferably the estolate ester) is the antibiotic of choice. If given within 2 weeks of onset of disease, it is capable of aborting or eliminating pertussis. If started after the onset of paroxysmal phase, it still reduces communicability and safeguards against superimposed bacterial infections. Symptoms are, however, not significantly reduced. It should be administered in a dose of 50 mg/kg/day in 4 divided doses for 2 weeks. It acts by eliminating pertussis organisms from the nasopharynx within 3 to 4 days.

Roxithromycin, *azithromycin* or *clarithromycin*, for just 5 to 7 days, gives as good or even superior results to 2-week course of erythromycin.

Alternatively, cotrimoxazole, ampicillin, amoxicillin or chloramphenicol may be employed.

Table 19.2: Various complications occurring in pertussis

- Otitis media is quite frequent.
- Pneumonia (including interstitial pneumonia) is a very serious complication, especially in infants.
- Collapse, emphysema, bronchiectasis, pneumothorax and pneumomediastinum; surgical emphysema.
- Convulsions and even encephalitis due to cerebral anoxia. Hemiplegia and mental subnormality may be left as sequelae. Causes of seizures in pertussis include cerebral hypoxia related to asphyxia, hyperpyrexia, hyponatremia resulting from syndrome of inappropriate secretion of antidiuretic hormone (SIADH) and alkalosis secondary to loss of gastric contents resulting from persistent vomiting.
- Epistaxis, subconjunctival hemorrhages and even cerebral hemorrhage.
- Frenular ulcer.
- Rupture of diaphragm.
- Rectal prolapse and umbilical and inguinal hernia because of overwhelming strain of violent cough.
- Flaring up of a pre-existing dormant tuberculous focus.
- Malnutrition as a result of frequent vomiting and disinclination to eat.

Betamethasone and salbutamol (preferably nebulization) may be employed in selected cases of severe coughing paroxysms.

Use of pertussis immune globulin in the first week of disease may considerably reduce the whoop but not cough and vomiting.

The treatment of complications will depend on their individual nature. Frenular ulcer shows speedy healing if touched with silver nitrate.

Prophylaxis

Active immunization with DPT is outlined in Chapter 10 (Immunization).

Experience with acellular pertussis vaccines, which are supposed to have lower incidence of local, systemic and CNS side effects than the whole cell vaccine, is gratifying. The vaccines have turned out to be effective both for primary and booster immunization.

There is sufficient evidence to the effect that the incidence, severity and duration of the disease is far less in the vaccinated than in the nonvaccinated subjects.

Close contacts, especially neonates of mothers with pertussis, must receive erythromycin estolate for 2 weeks. Those under 7 years and previously immunized need to receive a booster dose of DPT, unless a booster dose has been administered in the preceding 6 months, as well. The contacts who have not been immunized earlier should receive erythromycin for 2 weeks after the contact is broken, until cough in the index case ceases, or until the index case completes 7 days course of erythromycin.

In institutionalized epidemics, monovalent pertussis vaccine together with erythromycin is recommended.

Prognosis

Pertussis carries poor prognosis in infants below 1 year of age. There is high morbidity and mortality in the event of complications. Beyond 1 year of age, the prognosis is good provided serious complications have not occurred.

Long-term sequelae of pertussis in infancy include minor abnormalities of lung function and wheezing and other lower airway manifestations in adulthood.

DIPHTHERIA*

Diphtheria is an acute bacterial disease, characterized by formation of a membrane, primarily in the upper respiratory tract, and toxemic manifestations as a result of liberation of a powerful *exotoxin*.

It is rare under 6 months of age. Preschoolers are very prone to it. But the age incidence is now rising. Today, diphtheria is often seen in adolescents and adults as well. This is perhaps due to increased level of vaccination early in life with poor "coverage" in later years.

Etiopathogenesis

It is caused by *Corynebacterium diphtheriae*, a Gram-positive pleomorphic rod that grows on *Loeffler medium*.

Transmission of infection is by droplets from an individual with active disease or a carrier. A powerful necrotizing *exotoxin* that gets fixed to the tissues is responsible for signs and symptoms. The manifestations depend on the site of the membrane and its extent as well as on the age of the patient rather than the strain of the organism.

Epidemiology

Diphtheria occurs all over the world. It is in the winter months that maximum incidence is reported. In the developed areas, it tends to attack the grown-up children, the adolescents and the adults. This again appears to be related to the increased immunization among the infants and children in these areas.

Clinical Features

Diphtheria has a short incubation period, i.e. 3 days, the extremes being just 1 day and 6 days.

The clinical picture depends on the location of membrane, its extent and the age of the subject. The following types are recognized:

A. *Faucial diphtheria* Tonsils are the most frequent site of diphtheria in pediatric practice. The manifestation are:

- Sore throat and difficulty in swallowing
- General malaise and prostration
- Tachycardia
- Moderate fever

* A Greek term meaning a membrane

- *Membrane*: The aforesaid manifestations are followed by formation of a whitish-gray membrane, firmly attached to the underlying mucosa over tonsils, anterior pillars and uvula. It may extend over to the pharynx. It is difficult to remove the membrane without damaging the mucosa and thus without a bleed. The maneuver should, however, be avoided since it may cause greater liberation of the damaging toxin.
 - Cervical lymphadenopathy in severe cases.
- B. *Laryngeal diphtheria* Most serious but, fortunately, less common. The manifestations are:
- Hoarseness, aphonia and croup
 - Brassy or barking cough
 - Dyspnea and cyanosis in case of severe respiratory distress
 - Restlessness and anxiety
 - Prostration
 - “Bull-neck” due to gross cervical lymphadenopathy and brawny edema of the neck.
 - *Membrane* It is usually the extension of the membrane of the throat (faucial diphtheria) lower down into the larynx. Membrane may, however, be merely limited to larynx in a minority of the cases. The first is called “secondary laryngeal” and the second the “primary laryngeal” diphtheria. Membrane in the larynx can readily be seen on laryngoscopy.
- C. *Nasal diphtheria* It is uncommon (only 1 to 3% of all the cases of diphtheria) but a potent source of spread of infection to others. It occurs in infants. The manifestations are:
- Visible membrane over turbinates
 - Nasal discharge (serosanguinous and foul-smelling) which may be unilateral or bilateral
 - Frank epistaxis may occur occasionally
 - Excoriation of nose and upper lip
 - Nasal obstruction
 - Slight constitutional symptoms
- D. *Cutaneous and other rare diphtheria* Diphtheric membrane may be found on skin, open wounds, genitalia and conjunctiva, and in ears. The underlying ulcers are often painless and chronic.

Diagnosis

It is primarily clinical. In a suspected case, immediate action should be taken to examine the smears from

throat swab (or other affected site). When stained with methylene blue, the organisms are seen as rods with midpolar bar.

Culture on *Loeffler medium* is of value. Results of culture are available within 8 hours.

For quick diagnosis, fluorescent antibody technique is of greatest help.

Complications (Table 19.3)

Table 19.3: Various complications occurring in diphtheria

- Bronchopneumonia
- Nephritis (mere albuminuria in early stages)
- Myocarditis: It may occur any time during the course of the disease. The early development is a bad prognostic sign.
- *Paralysis* About 12 to 21% of the cases suffer from the post-diphtheric paralysis somewhere between first and sixth week of illness. The following are the various types seen:
 - a. Pharyngeal and palatal paralysis are manifested by nasal voice, dysphagia, nasal regurgitation, and failure to lift the palate.
 - b. Ocular paralysis occurs late and is second in frequency. It is manifested in the form of diplopia, squint, ptosis, ophthalmoplegias, etc.
 - c. General paralysis occurs quite late. There may be quadriplegia, paralysis of the neck muscles and respiratory embarrassment, as a result of involvement of the diaphragm from phrenic nerve paralysis. Even CSF protein may be elevated. This complication closely simulates Guillain-Barré syndrome.
- Vasomotor disturbances in the form of hypotension and cardiac failure 2 to 3 weeks after onset of the disease occur rarely.
- Gastritis
- Hepatitis

Treatment

Specific treatment consists of immediate administration of antitoxin, i.e. antidiphtheric serum (ADS), 20 to 100 thousand units (intramuscularly, intravenously or both). The actual dose would depend on the site and extent of membrane and degree of toxemia. Table 19.4 gives the suggested dose of ADS in different situations. Needless to say, ADS should only be administered after the sensitivity test to guard against the risk of anaphylactic reaction. Desensitization is needed in case of sensitivity to ADS (Table 19.5).

Table 19.4: Recommended dosage of ADS for treatment of diphtheria

Situations	Dosage range (units)
Laryngeal or pharyngeal diphtheria of 48 hrs or less duration	20,000 to 40,000
Nasopharyngeal diphtheria	40,000 to 60,000
Extensive disease of over 3 days duration or with brawny neck edema	80,000 to 100,000

Table 19.5: Recommended regimen for desensitization in case of ADS

0.1 ml of 1:1,000 saline dilution (IV) followed by an increment every 15 minute if no anaphylaxis occurs
0.3 ml of 1:1,000 saline dilution (IV)
0.6 ml of 1:1,000 saline dilution (IV)
0.1 ml of 1:100 saline dilution (IV)
0.3 ml of 1:100 saline dilution (IV)
0.6 ml of 1:100 saline dilution (IV)
0.1 ml of 1:10 saline dilution (IV)
0.3 ml of 1:10 saline dilution (IV)
0.6 ml of 1:10 saline dilution (IV)
0.1 ml of undiluted ADS (IV)
0.2 ml of undiluted ADS (IV)
0.6 ml of undiluted ADS (IV)
1.0 ml of undiluted ADS (IV)

Antibiotics (preferably procaine penicillin or erythromycin; alternatively amoxicillin, rifampicin or clindamycin) should be administered for 2 weeks. The aim is to stop production of diphtheria toxin, eradicate the organisms, prevent their spread, and eradicate group. A beta-hemolytic streptococci that are known to complicate upto one-third patients of diphtheria. Only after 3 negative cultures, the patient is considered cured. Carrier state is effectively treated with penicillin G or erythromycin.

During convalescence, if Schick test is positive, diphtheria toxoid should be given since not all subjects develop adequate immunity after the disease. *General measures* include proper bed rest for about 2 weeks, isolation, maintenance of fluid and dietetic adequacy (may need tube feeding or IV fluids) antipyretics, frequent aspiration and high humidity. Tracheostomy and mechanical respirator may also be needed in case of respiratory obstruction or paralytic involvement of the diaphragm.

Prophylaxis

The only reliable method of achieving this is active immunization with DPT or DT.

All close contacts need to have Schick test and culture. If the contact is Schick positive as well as culture positive, full treatment for diphtheria must be instituted. If Schick test is negative but culture is positive, the contact should be considered a carrier. If the carrier is immunized earlier, he needs a booster dose of toxoid and erythromycin or benzathine penicillin. If he is not (that include subjects whose immunization status is not known), he should receive first dose of toxoid and 5,000 to 10,000 units of ADS (IM).

Prognosis

It is guarded. Almost 50% of the cases die if left untreated. With recommended treatment, mortality is around 4 to 5% and is usually the result of myocarditis. Institution of specific therapy on the very first day of disease may reduce the mortality to as low as less than 1%. Delay in instituting specific therapy until the fourth day raises the mortality about 20 times. The survivors do not, as a rule have any paralytic sequelae. Infrequently, diphtheria may cause permanent cardiac damage.

EPIDEMIC TYPHUS

This disease is caused by *Rickettsia prowazekii*, a gram-negative non-flagellate coccobacillus and is more common in persons living in overcrowded unhygienic conditions. Transmission is through human body louse which becomes infected by feeding on infected individuals.

Clinical Features

Incubation period is usually less than 14 days. Common presenting manifestations are fever, severe headache, abdominal tenderness and macular rash. Remaining manifestations include chills, myalgia, arthralgia, anorexia, nonproductive cough, dizziness, photophobia, nausea, vomiting, diarrhea, constipation, abdominal pain, tinnitus, meningismus, visual disturbances, etc. Occasionally, myocarditis may occur.

Diagnosis

Epidemic typhus should be considered in the differential diagnosis of typhoid, dengue, meningococemia, measles and during epidemics of "mystery" fevers defying diagnosis.

Weil-Felix reaction (serum agglutinins against proteus XO-19 and OX-2) is positive.

Treatment

Doxycycline orally or intravenously (2.2 mg/kg/24 hours, divided in 2 doses) or chloramphenicol (50-100 mg/24 hours, divided in 4 doses), is given over a period of 5 days or until the child becomes afebrile for 2-4 days to safeguard against relapse.

Prevention

Vector destruction is important to control epidemics. A vaccine too is now available.

TYPHOID FEVER (*Enteric Fever*)

An acute bacterial infection, characterized by constitutional symptoms like prolonged pyrexia, prostration and involvement of spleen and lymph nodes.

It does not cause life-long or even sufficiently prolonged immunity. Second attack often occurs.

Etiopathogenesis

The disease is caused by *Salmonella** *typhi*. *Salmonella paratyphi* A, B and C** lead to a typhoid-like illness, the so-called *paratyphoid fever*. The typhoid and paratyphoid fevers are collectively known as *enteric fever*. In our country, at least 90% cases of enteric fever are due to *S. typhi*. This is perhaps true of most other tropical and subtropical regions, especially where standards of sanitation and hygiene are poor.

Transmission is by contaminated food, unboiled milk, vegetables or water. Housefly plays a significant role by carrying bacilli from urine or stools of an active sufferer or a carrier to food.

After ingestion, there is initial proliferation of the organisms in the lymphoid tissue of intestines (mostly in ileum), resulting in swelling of the *Peyer patches*. This is followed by invasion of the blood stream. It is about this time that onset of clinical symptoms occurs. Towards the fag-end of second week, ulceration of ileum results from shedding of intestinal

lymphoid tissue. Additional pathologic changes include enlargement of mesenteric lymph nodes, focal necrosis of liver, splenomegaly, myocarditis, muscle degeneration and respiratory infection.

Epidemiology

Typhoid has worldwide distribution. In the West, its incidence has declined to the point of near "rarity". This is because of rising standards of sanitation and hygiene. In India and other developing countries, typhoid, however, continues to be a major public health problem. Poor sanitary conditions, lack of safe drinking water, illiteracy, ignorance, and low standards of personal, group and community hygiene—all contribute to this unfortunate state of affairs.

The peak incidence of typhoid occurs in summer and rainy season when fly population shows enormous increase.

Contrary to the popular belief and West-oriented teaching, typhoid is certainly common in infants and young children in countries of the Third World. A recent survey in a slum-population of Delhi revealed an overall incidence of 9.9 per 1000 with an almost three-fold higher incidence in children under 5 years. No doubt, the clinical picture in pediatric typhoid is remarkably different from what is often seen in the grown-ups.

Needless to say, chronic carriers happen to be the major source of spread of infection.

Clinical Features

The *incubation period* is 10 to 14 days with extremes of 5 and 40 days.

Unlike adults, who show insidious onset with step-ladder rise in temperature, **typhoid in children often manifests suddenly**. The manifestations are rapid rise of temperature, extreme malaise, anorexia, headache, vomiting, and abdominal pain and distention. The paradoxical relationship of low pulse rate and high pyrexia is not common in children. **Some cloudiness of consciousness** (this is what the term, *typhoid*, denotes) is almost always present. Diarrhea is seen more often than constipation. Abdomen has a characteristic *doughy* feel. Spleen and, at times, liver are significantly palpable (Fig. 19.2). Bradycardia, an important sign in adults, is not a common finding in pediatric patients.

* Besides enteric fever, *Salmonella* may cause (i) septicemia, (ii) enteritis/dysentery, (iii) meningitis, (iv) pneumonia/bronchitis, (v) osteomyelitis, (vi) appendicitis and (vii) peritonitis.

** *Salmonella paratyphi* C infection is very uncommon



Fig. 19.2: Enteric fever. Note the splenomegaly detected in the third week. Widal test showed an 'O' antibody titer of 1 in 240. The child had been admitted for unexplained pyrexia of 18 days duration

A rash (macular *red rose spot*) is said to appear about the fifth day on the front and the back of the trunk. In India, such a rash is, in actuality, very infrequently seen. This author learns from an outstanding Indian pediatrician of international repute that he had seen it on only 4 occasions throughout his professional career spread over 40 years. This appears to be the result of 2 factors: (a) many cases of typhoid do not at all have it, and (b) most of our population is dark-skinned in whom it is difficult to see it.

Sometimes, manifestations of typhoid may simulate the clinical picture seen in bacillary dysentery, respiratory infection or meningitis.

In typhoid of infancy and early childhood, clinical profile usually includes fever with or without diarrhea, convulsions and, particularly, anemia. Anemia may be secondary to blood loss or hemolysis from autoantibodies.

Typhoid spares no age. Even neonates may develop the disease as a result of vertical transmission. *Neonatal typhoid* manifests, 72 hours after birth, with vomiting, abdominal distention, diarrhea and pyrexia of variable intensity. Accompanying manifestations include seizures, jaundice, hepatomegaly, anorexia and weight loss.

Diagnoses

The most important is the clinical suspicion. Any persistent pyrexia of unknown origin must be suspected of being typhoid fever and investigated accordingly. Tuberculosis, malaria, kala-azar, brucellosis, urinary tract infection and reticulosis are among the important differential diagnoses. Onset with acute abdomen and vomiting may suggest an abdominal emergency, like appendicitis, in which case an unnecessary surgery is likely to be resorted to. In the presence of chest manifestations, a typical bronchopneumonia may require to be excluded. If meningeal signs are there, meningitis must be ruled out.

Eosinopenia or complete absence of eosinophils is a reliable finding. *Leukopenia* with relative lymphocytosis, described as an important feature of typhoid, is most often absent. This is perhaps due to the fact that the patients generally report fairly late, particularly in developing countries.

Blood and bone marrow culture for *S. typhi* is the most reliable method under ideal conditions. Positive cultures may be obtained at any stage of typhoid.

Widal test is another important diagnostic tool. In our conditions of endemicity of typhoid, a 'O' antibody titer of 1 in 160 or more in the second week of symptoms is suggestive of the disease. A rising titer over a period of 7 to 10 days is, however, of greater value. In order to exclude the anamnestic responses, it is advisable to perform a modified Widal test along with a conventional Widal test.

The chances of *Widal test* turning to be positive in the second week are around 60% and in the third week 80%.

Rapid serodiagnostic procedures, especially counter-immunoelectrophoresis (CIEP), ELISA and coagglutination (COAG) are now emerging as reasonably sensitive, and specific, simple and economic diagnostic tools.

In suspected *chronic carriers*, urine and stool cultures should be done. In strongly suspected cases with negative cultures of urine and stool, duodenal aspirate needs to be cultured.

Complications

Unlike adults, children with typhoid fever have far less incidence of abdominal complications. Extra-abdominal problems, especially those of respiratory and nervous system, are, however, more frequently encountered (Table 19.6).

Treatment

Specific

3

Chloramphenicol is the time-honored antibiotic of choice in proved typhoid. It should be administered for 10 to 14 days (5 to 7 days after the subject becomes afebrile; defervescence results within a week in most instances). A 21-day course is recommended in children with significant malnutrition and/or complications.

Amoxicillin, ampicillin, cotrimoxazole and furazolidine are other effective chemotherapeutic agents.

Recently, multidrug-resistant strains (MDRS) of typhoid have posed considerable problem. The recommended alternative therapy in such cases is a fluoroquinolone like ciprofloxacin, or a third generation cephalosporin like ceftriaxone, cefoperazone or cefatoxime as such or preferably in combination with an aminoglycoside like gentamicin, amikacin or netramycin. The initial apprehension that quinolones may cause damage to the growing

cartilage in young children is not supported by the clinical experience so far. Besides extraordinary efficacy in MDRS, quinolones are cost-effective and well tolerated. They may also cure the carrier state. Unfortunately, quinolone-resistant strains of *S. typhi* are also beginning to add to the dilemma. It is not unusual for both sensitive strains and MDR strains of *S. typhi* to exist concurrently. More recently, excellent results have been obtained by short course oral therapy with ofloxacin, cefixime and ceftibuten in MDR pediatric typhoid fever. Oral cefixime has been found to be an effective switch or step-down therapy, i.e. switching from an IV therapy (say with ceftriaxone) after a few days (say 2-3 days) when the patient's condition has improved. Other agents which are good for switch therapy include quinolones, and coamoxiclav.

Administration of *steroids* is recommended in severely toxemic patients or prolonged illness for a short period of only 2 to 3 days.

General Measures

These include isolation of the patient, careful disposal of the excreta, bed rest, good nursing care and attention to maintenance of adequate fluid and dietary intake. A nourishing light fluid or semisolid diet is advisable during the first few days. **Rigid dietary regimens are no longer recommended.** Vitamin and hematinic supplements are often needed in most of the patients. Occasionally, blood transfusion (whole blood) is warranted in infants and small children with significant anemia. Blood transfusion is also required in cases of intestinal and other severe hemorrhages. Surgical intervention may be needed for intestinal perforation.

As far as possible, use of antipyretic agents to control fever should be avoided. *Hydrotherapy (tepid sponging)* is the more favored method of treating hyperpyrexia of typhoid fever.

For eradication of infection in chronic carriers, high dose ampicillin (preferably along with probenecid), given for 4 to 6 weeks, is recommended. Quinolones may also be effective (Table 19.7). Cholecystectomy is indicated in case of failure of drug therapy in chronic gallbladder infection.

Table 19.6: Various complications occurring in typhoid fever

Abdominal: Intestinal perforation, hepatitis, liver abscess, fatty liver, cholecystitis, urinary tract infection.

Respiratory: Bronchopneumonia, lobar pneumonia, bronchitis, pleurisy, empyema, pulmonary infarction.

Cardiovascular: Toxic myocarditis, pericarditis, endocarditis, arteritis, venous thrombosis.

Neurologic: Encephalopathy, meningitis, myelitis, Guillain-Barré syndrome, cranial nerve involvement, choreiform movements, monoplegia, hemiplegia, acute cerebellar ataxia, aphasia, psychiatric syndromes like acute confusion, severe depression and schizophrenia.

Hematologic: Hemolytic anemia, bone marrow depression, consumptive coagulopathy, hemolytic uremic syndrome.

Miscellaneous: Superficial abscesses and boils, bed sores, bleeding, parotitis, otitis media, tonsillitis, alopecia.

Table 19.7: Antibiotic therapy in typhoid fever

Drugs	Dosage	Remarks
<i>Conventional Agents</i>		
Chloramphenicol	50-100 mg/kg/day (O) in 4 divided doses For 10-14 days	Drug of choice; resistant observed in 1990s to it is now on decline
Cotrimoxazole	10 mg/kg/day (O) Sulfamethoxazole 50 mg/kg/day trimethoprin, in 2 divided doses	
Ampicillin	100-200 mg/kg/day in 4 divided doses	
Amoxycillin	100 mg/kg/day in 4 divided doses	
Furazolidine	8-10 mg/kg/day in 3-4 divided doses	Effective with equivocal results
<i>New Agents</i>		
Cefixime	20 mg/kg/day (O) in 2 divided doses	May be employed as such or as a switchover therapy
<i>Ceftibuten</i>		
Cefatoxime	100 mg/kg/day (IM,IV)	
Ceftriaxone	100 mg/kg/day (IM,IV)	
Ciprofloxacin	20 mg/kg/day (O) in 2 divided doses	May be avoided in small children because of risk of arthropathy from damage to the cartilage
Ofloxacin	10 mg/kg/day (O) in 2 divided doses	

Prophylaxis

Active protection is accomplished by use of *typhoid vaccine* (monovalent and not trivalent TAB) as described in Chapter 9. It confers a high degree of immunity. Two modern vaccines (Vi vaccine and oral vaccine) are currently popular. However, evidence has accumulated to the effect that the classic heat-inactivated whole cell vaccine is more effective. Since none of the available vaccines is quite effective in young infants, there is a need for an inexpensive Vi conjugate vaccine that could be incorporated in the national or EPI programs.

The most important and most effective strategy for control of typhoid, however, revolves around public health measures.

There should be well-organized efforts and planning to improve sanitary conditions and personal, groups, community, food and kitchen hygiene. The public health authorities should ensure clean water supply, proper sewage disposal and control of flies. Education of the public is also of paramount importance.

Detection and treatment of carriers is another important measure to contain the spread of typhoid fever.

Prognosis

With adequate treatment, prognosis is generally good. For some unknown reason, it has a more

favorable prognosis in children though, in infants, it is rather not quite encouraging. Poor nutritional status and such complications as perforation, severe hemorrhage, meningitis or endocarditis, resulting in high morbidity and mortality, adversely affect the course of illness. In India, mortality rate, on an average, is around 2%. This is a remarkable decline compared to the preindependence figures of 25 to 50%.

Relapse is said to occur if the individual again develops manifestations of the disease after about 1 to 2 weeks of stoppage of antibiotic therapy for typhoid fever. It warrants full therapy. Multiple relapses occasionally occur in a single subject.

Chronic carrier state is said to occur if the individual excretes *S. typhosa* 3 months or more after the attack of typhoid fever. Such subjects have chronic gallbladder infection or chronic urinary carriage, the latter being rare except in patients with schistosomiasis.

Some authorities recommend giving typhoid vaccine (preferably whole cell killed) after full recovery from typhoid since one attack does not provide solid or long-lasting immunity and, therefore, chance of a second episode, though very low, does exist. It is argued that the child with typhoid is likely to go back to the same environment with continuing risk of another infection.

BRUCELLOSIS

Also called undulant fever, mediterranean fever or goat milk fever, this disease is rare in children in India. It, however, needs to be considered in cases of unexplained pyrexia of prolonged duration, especially with hepatosplenomegaly and lymphadenopathy.

Etiopathogenesis

Brucellosis is caused by gram-negative organism, *Brucella*, which is known to have at least six species that are transmissible to man.

Infection usually occurs following ingestion of raw milk or one of its products.

Following entry into the body, the organisms are phagocytized by leukocytes and monocytes and spread throughout the reticuloendothelial system where they grow further as intracellular parasites. The body responds to the organisms by producing a variety of antibodies. IgM antibodies develop early followed by IgG antibodies which eventually dominate.

Granuloma formation, especially in liver, spleen, lymph nodes and bone marrow constitutes hallmark of the disease. Granulomatous involvement of gallbladder, testes, heart, brain, kidney, bone and skin may also occur.

Clinical Features

Incubation period varies from few days to several months.

Onset is usually insidious with such prodromal symp-toms as weakness, weight loss, exhaustion, anorexia, constipation, headache, muscle pains, etc. With progres-sion of the disease, the child develops high pyrexia, especially towards evening, with diaphoresis, abdominal pain, epistaxis and cough.

Hepatosplenomegaly and cervical and axillary lym-pha-denopathy are prominent findings. Chest auscul-tation may reveal crepitations.

Diagnosis

Most useful diagnostic test early in disease is brucella agglutination test showing titers beyond 1:160.

Complement-fixation titer of 1:16 or higher is diagnostic later in the course of the disease.

Definitive diagnosis is by isolation of the organism in cultures of blood, abscesses or infected tissues.

Treatment

Tetracyclines, as such or in combination with streptomycin, rifampicin, or gentamicin, forms the cornerstone of treatment of brucellosis. Cotrimoxazole as also amoxicillin-gentamicin combination have also been used with good results.

Prognosis

Prognosis following specific chemotherapy is excellent.

TETANUS

An acute bacterial disease, characterized by painful spasms and stiffness of muscles as a result of a powerful neurotoxin. Recurrences are rare.

Etiopathogenesis

The causative organism, *Clostridium tetani*, is widely distributed in the soil, dust and feces of animals and humans.

Transmission is usually through invasion of an injury (howsoever minute) with the tetanus bacilli or contaminated umbilical cord in the newborn (neonatal tetanus). In the latter situation, the usual mode of contamination is by septic cutting scissors or knife. Dust or animal dung is customarily applied to the cord stump by some tribes and in certain areas of our country in particular.

The bacilli, after entering the circulation, get attached to the motor endplate in muscles and motor nuclei in the nervous system.

Epidemiology

The disease is worldwide in distribution but is especially a **leading cause of death in the newborns of tropics and subtropics**. Some 110,000 cases of neonatal tetanus are estimated to occur annually in India. About 100,000 of them (90%) die.

The incidence is highest among agriculture workers, the rural population and at periods of life when an individual is more exposed to trauma. There is no notable seasonal variation.

Clinical Features

The *incubation period* varies from 3 days to 14 days. The minimum recorded is 1 day and the maximal several months. Shorter the incubation period, severer the disease.

Three varieties of tetanus are usually recognized, namely localized, generalized and cephalic.

Localized tetanus is characterized by pain, constant rigidity and muscle spasm in the region of the injury. It may occasionally be associated with chronic otitis media. The complaints may take weeks to regress fully or occasionally, progress to generalized tetanus.

Generalized tetanus usually has a sudden onset with muscle spasm and cramps, particularly about the location of inoculation, back and abdomen. The earliest manifestation in a newborn may be the refusal to take feed which should arouse suspicion. Restlessness, irritability, difficulty in swallowing (even difficulty in sucking) and, at times, convulsions soon follow.

In the next 48 hours, the clinical picture worsens. Neck rigidity, positive *Kernig sign* and trismus (difficulty in opening the mouth since the masseters are stiff) become apparent. The face assumes a typical expression called risus sardonicus. The latter consists of clenching of the jaw, laterally-drawn lips and raised eyebrows. There is also increasing stiffness of upper limbs and legs. The former are generally kept flexed, the latter hyperextended.

A typical tetanic spasm lasts for 5 to 10 seconds and consists of agonizing pain, stiffness of the body which gets almost arched backward with retraction of head (*opisthotonos*) and clenching of jaw and hands. As the disease progresses, a very simple stimulus also precipitates an attack. In advanced cases, spasms may become almost a continuous and constant feature.

Low-grade fever is usually present. Fever may, however, be as high as 104°F (40°C).

A patient may die during a bout of tetanic spasms due to cerebral anoxia, respiratory or cardiac failure, hyperthermia or overexhaustion.

Cephalic tetanus, a rare variety of tetanus, is characterized by paresis or paralysis of one or more of the cranial nerves (usually 7th) in addition to the spastic manifestations which may initially be confined to head and neck but, usually later, involve rest of the entire body. It follows usually an injury in the region of head and neck. According to one hypothesis, toxin

causes the paralytic phenomenon involving cranial nerves through patchy involvement of the nuclei. Prognosis is relatively good, complete recovery occurring in a large majority of the cases.

Diagnosis

In a large majority of the cases, the clinical picture is sufficiently diagnostic.

Tetanus bacilli may be cultured from excised necrotic tissue. This procedure is, however, hardly needed. Moreover, it is not feasible in areas where the disease is most endemic.

Complications

- *Resulting from respiratory muscle spasm:* Aspiration pneumonia, atelectasis, mediastinal emphysema, pneumothorax.
- *Resulting from tetanic seizures:* Laceration of tongue, buccal mucosa, etc., intramuscular hematomas, vertebral fractures.
- *Resulting from poor intake:* Malnutrition, dehydration and dyselectrolytemia.
- *Resulting from poor autonomic stability:* Myocarditis, arrhythmias, hypertension, hypotension.

Treatment

The cornerstone of specific therapy is the *antitoxin*. ATS should be administered in a dose of 1,00,000 IU to children and 30,000 to 50,000 IU to newborns immediately after making the clinical diagnosis.

The total dose may be given intramuscularly and/or intravenously.

Local infiltration of the ATS at the site of the wound may be of value if surgical excision is not workable.

Some authorities advocate that, simultaneous with passive immunization (ATS), the patient should receive active immunization with *toxoid*, using an initial dose of 0.5 to 1 ml followed by 3 further doses at intervals of 3 weeks with increasing doses varying with child's age.

Whether ATS, alone or in combination with toxoid, is of any significant value in tetanus is not as yet fully clear. Since no one has so far demonstrated if a patient suffering from tetanus can be saved without such a treatment, this therapy deserves to be employed under existing circumstances.

High dose of an antibiotic, preferably injectable penicillin, should be given. Penicillin has some action on *Cl. tetani* and also prevents secondary infections.

Recently, gratifying results have been obtained by addition of pyridoxine to the conventional regimen in neonatal tetanus.

Human tetanus immunoglobulin (HTIG), 500 to 3,000 IU, should be administered (IM) at the earliest. There is evidence that intrathecal HTIG is of added value. TIG is safe, causing no allergy or anaphylaxis. It attains protective levels rapidly. It, however, has no effect on the toxin fixed to neural tissue. Further, it is incapable of crossing the blood-brain barrier.

General measures include isolation of the patient in a quiet dark room, provision of good nursing care and minimal of disturbance. Maintenance of adequate fluid and nutritional intake is important. For this purpose, intragastric and/or intravenous therapy may be given.

Muscle spasms are controlled with two or more of the sedatives like diazepam, phenobarbital, chlorpromazine, paraldehyde, chloral hydrate, mephensin, baclofen, dandrolene, etc. Magnesium sulfate is of value in controlling hypertonicity and spasms and stabilizing cardiovascular parameters, etc. Even pethidine can be given. **Morphine is, however, contraindicated.** Sedation is given *round the clock*. The doses are, as a rule, high but need to be adjusted depending on the individual merits of each patient. Best survival rates have been achieved by employing IV infusion of neuro-muscular agents (pancuronium, vecuronium in dose of 0.1 mg/kg/hour). The complete respiratory paralysis thus produced is managed by artificial ventilation.

Tracheostomy, oxygen inhalation and positive-pressure respiration significantly improve the prognosis, especially when respiratory difficulty is present or it is anticipated.

Prophylaxis

Active immunization is outlined in Chapter 10. Remember that active immunization of pregnant mother with tetanus toxoid is an effective and definitive preventive measure. Previously immunized mothers need just one dose and not 2 doses recommended for the nonimmunized ones.

For *passive immunization*, ATS should be given in doses of 1 to 3 thousand IU intramuscularly, the dose

varying with child's age. At the same time it is better to give 1 ml toxoid subcutaneously. Two more injections of toxoid should be given later at 1 month intervals. This recommendation is for nonimmunized individuals with dirty and deep wounds. These patients should also have adequate surgical toilet of the wounds and injectable penicillin.

As for previously immunized subjects, a recall dose of toxoid suffices.

Conduction of deliveries, both in and outside the hospital, under clean and aseptic conditions and application of clean dressing during healing of cord are also important.

Prognosis

Tetanus is a dreadful disease. Mortality rate is in the neighborhood of 50%. It is the worst in neonatal tetanus with an average of 50 to 75%. Under ideal circumstances, providing excellent nursing care and facilities like intermittent positive pressure respiration, it may be cut down to about 20%.

A proportion of the survivors of neonatal tetanus may end up with cerebral palsy, paralysis, mental retardation, and behavioral problems as sequelae of apnea and anoxia resulting from prolonged attacks of spasms.

A survivor from tetanus needs active immunization since tetanus does not confer immunity against future disease.

LEPROSY (*Hansen Disease*)

Leprosy is a chronic granulomatous disease characterized by skin lesions and/or involvement of the nerves.

India is responsible for 25% of the 12 million total cases of leprosy in the world. In the north Indian states, its incidence is far less than in the rest of the country.

Unlike adults, early manifestations of leprosy in childhood are often misleading. Generally, it is not diagnosed until the age of 4 to 5 years though the child may have been infected much earlier.

Etiopathogenesis

Leprosy is caused by *Mycobacterium leprae*. The source of infection is a patient, either from the family or from the community.

In a large majority, infection occurs either from bacteria-containing discharge from the open skin lesions or from ulcers in nose, mouth, etc. Recently, it has been demonstrated that infection can occur from the bacilli in the breast milk.

The most important portal of entry for the would-be host is a cut or abrasion in skin. Direct contact is not essential. Indirect contact through infected objects can also cause transmission of infection. It has been suggested that infection via respiratory or gastrointestinal tract is also possible.

Clinical Classification/Features

A. Lepromatous leprosy: In a typical case, body shows little resistance to the spread of bacilli which disseminate by billions, especially in subdermal and nervous tissues. In the nose, involvement of the cartilage may cause collapse of hard structures. Hair follicles are notably affected, causing loss of eyebrows. This, together with swelling of hands and feet, is a useful pointer to diagnosis.

In a classical severe case, skin appears thickened and greasy. Where the body attempts to localize the disease, painless nodules appear. The ears, nose, chin, elbows and knees are important examples of such sites. Occasionally, numerous small, pale flat macules with loss of sensation (Fig. 19.3) may be found. The nerves are usually invaded but inflammatory symptoms are minimal in the early stages.



Fig. 19.3: Hypopigmented skin patch with definite loss of sensation in an adolescent. The clinical diagnosis of leprosy was supported by acid-fast positive skin smear

The skin smears are strongly positive but lepromin test is negative.

Allergic lepra reactions, particularly while on treatment with sulfones, constitute a characteristic feature. High fever, arthralgia, adenopathy, iridocyclitis, orchitis and erythema nodosum—the so-called *Arthus phenomenon*—are prominent among the various lepra reactions.

B. Tuberculoid leprosy: Here, body shows well-developed resistance to invasion by the bacilli. The skin smears are negative. Lepromin reaction is strongly positive.

The skin manifestations are characteristic. Macules are few and well-defined with raised margins and central healing. These are always anesthetic, except over the face.

The peripheral nerves are often involved at random in contrast to lepromatous type where polyneuritis is essentially distal and symmetrical. The ulnar, peroneal and great auricular nerves are most frequently involved, showing clinical enlargement with pain and anesthetic areas of skin. In addition, *glove* and *stocking* anesthesia of the hands and feet is a common feature. Trauma causes secondary injuries, ulceration and infection. Contracture of the medial two fingers from ulnar involvement is a typical diagnostic sign.

C. Borderline leprosy: Between the typical lepromatous tuberculoid cases are a large number of borderline cases with manifestations of both the types.

This type, unlike the lepromatous and tuberculoid types, is immunologically unstable. If untreated, it can degenerate from *borderline tuberculoid* to *borderline lepromatous*.

Treatment may shift *borderline lepromatous* to *borderline tuberculoid*. This is frequently accompanied by acute neuritis and flaring up of skin lesions (*reversal reaction*).

Diagnosis

A punch *biopsy* from edge of the skin or nose lesion confirms the clinical diagnosis.

Treatment

The time-honored drug for treatment of leprosy continues to be *dapsone* or diaminodiphenyl sulfone (DDS). For dosage see Tables 19.8 and 19.9.

Table 19.8: Initial dose of DDS to be given on alternate days

Weight range	Dose
Below 10 kg	10 mg
10 to 20 kg	25 mg
20 to 30 kg	50 mg
Beyond 30 kg	100 mg

Table 19.9: Maximum dose of DDS to be given on alternate days

Stage of treatment	Dose
First month	5 mg
Second month	10 mg
Third month	25 mg
Fourth month	50 mg
Fifth month	100 mg

Clofazimine (Lamprene) is a far better antileprosy drug. But it is also far more expensive than DDS. The dose is 100 mg twice daily for all ages.

The latest introduction in the antileprosy regimen is *rifampicin* which is safe and very effective. But it also costs exorbitant. It has been suggested that the patient may be given a single large dose of this drug to destroy the majority of the bacilli and then followed with maintenance dose of clofazimine/DDS.

Duration of treatment should be minimum of 7 years for lepromatous and borderline lepromatous, 5 years for *borderline tuberculoid* and 3 years for tuberculoid types.

In the wake of appearance of multidrug resistant (MDR) strains, the World Health Organization (WHO) has recommended the following combinations of multiple drugs:

- For *multibacillary leprosy*, 24 pulses of multiple drugs, each pulse administered over a period of one month (Table 19.10).
- For *paucibacillary leprosy*, the recommended regimen is 6 pulses of MDT, one every month (Table 19.11).

Rehabilitation is a “must” in the presence of deformities.

Prevention

BCG *vaccination* is said to give some degree of protection.

Maintenance of good nutrition and hygiene in children exposed to infected lepromatous or

Table 19.10: WHO multidrug therapy (MDT) in MDR leprosy (multibacillary)

Drugs	Dosage	
	6-9 years	10-14 years
Rifampicin (once a month, supervised)	300 mg	450 mg
Clofazimine (once a month, supervised)	100 mg	150 mg
Clofazimine (self-administered)	50 mg (daily or twice a week)	50 mg (daily or on alternate day)
Dapsone (once a month, supervised)	50 mg	50 mg
Dapsone (daily, self-administered)	25 mg	50 mg

Table 19.11: WHO multidrug therapy (MDT) in MDR leprosy (paucibacillary)

Drugs	Dosage	
	0-5 years	6-14 years
Rifampicin (once a month, supervised)	300 mg	450 mg
Dapsone (daily, self-administered)	25 mg	50 mg

borderline lepromatous cases contributes to prevention. Whether they should be kept on prophylactic doses of DDS remains at present debatable.

SYPHILIS

Syphilis is caused by a spirochete, *Treponema pallidum*.

In the *congenital syphilis*, infection is acquired from the infected mother during the second half of pregnancy.

In the relatively rare *acquired syphilis*, infection is acquired through kissing, by sexual contact or through infected nipples. Except for the primary chancre, which is infrequent in childhood, rest of the signs and symptoms are similar to those seen in adults.

Clinical Features

Early congenital syphilis The manifestations are evident within the first six weeks of life. These include *snuffles* (profuse mucopurulent nasal discharge), excoriation of the skin on top of upper lip and the left over fine scars called *rhagdes* and lesions of skin (most

prominent over back, buttocks and posterior aspect of thighs). The soles and palms may show bullous lesions. Mucous patches, ulcerations and fissures may occur in the mouth and anus.

Anemia, hepatosplenomegaly, jaundice, fever, failure to thrive, lymphadenopathy and chorioretinitis are other noteworthy features.

Painful osteochondritis and/or periostitis may cause pseudoparalysis (*Parrot paralysis*).

The neurologic manifestations include permanent brain damage, hydrocephalus and optic atrophy. This is termed *meningovascular syphilis*.

Syphilitic nephrosis is required to be considered in the presence of periorbital puffiness and pedal edema in a known or suspected case of the disease.

Such serious complications as bronchopneumonia (*pneumonia alba*) and hepatic failure may prove fatal.

Late congenital syphilis It usually manifests after the age of 3 years or more. The signs and symptoms include interstitial keratitis, condylomata—gummatous lesions of skin, mucous membrane or skull and other bones—*Clutton joints* (symmetrical painless effusion of both knee joints), *Sabre tibia* (thickening and forward bowing of tibia due to calcification along the anterior ridge), bossing of skull, saddle nose, perforation of palate, deafness, paroxysmal hemoglobinuria and neurosyphilis. The last-named may present as meningitis, juvenile tabes, optic atrophy, convulsions, nerve deafness or cranial nerve palsies.

Visceral lesions, including involvement of cardiovascular system, are infrequent.

Box 19.1 lists the syphilitic stigmata.

Acquired syphilis: It may be primary, secondary, latent and late.

Primary syphilis is characterized by “chancre”, a shallow, painless ulceration with a clean base and firm lifted edges at the site of inoculation.

Secondary syphilis occurs 6 to 8 weeks after the primary syphilis and is characterized by

“condylomata”, plaque-like lesions resulting from enlargement, coalescing and erosion of the papules.

Latent syphilis means that clinical manifestations of syphilis are absent but a specific antitreponemal antibody test is positive as also there is history of untreated syphilis in the past, exposure to the disease, or birth of a child with congenital syphilis.

Late syphilis, slowly progressive disease that may involve any organ, does not occur in childhood.

Diagnosis

Differential Diagnosis Syphilis is another “master immitator”. It should be considered in diagnosis of:

- Coryza going on and on over an unusually prolonged period,
- Prolonged fever,
- Odd skin lesions which do not heal within a reasonable time, e.g. atypical scabies, unusual skin rashes, mucocutaneous moniliasis, pemphigus.
- Poliomyelitis,
- Birth injuries,
- Infections like rubella, cytomegalic inclusion body disease or toxoplasmosis,
- Rickets, scurvy, arthritis, osteomyelitis,
- Neurologic conditions like odd meningitis, hydrocephalus, deafness, mental retardation, etc.
- Anemia, hemoglobinuria
- Nasal diphtheria.

Once syphilis is suspected, the diagnosis must be confirmed by one or more of the following investigations:

1. Demonstration of the causative organism, *Treponema pallidum*, in scrapplings from skin or mucous membrane by *dark-field examination*.
2. *X-ray examination may show* (i) periostitis of long bones, giving an appearance of double contour, (ii) dactylitis, and (iii) osteochondritis. A pathognomonic sign is the so-called *Wimberger sign*—symmetrical destruction (“bite”) over the medial aspect of upper part of tibia.
3. Serologic tests such as VDRL.

Treatment

Penicillin (procaine), 4 to 6 lakh units everyday for 7 to 10 days in early and mild cases and for about 14 to 21 days in late congenital syphilis or in neurosyphilis, gives gratifying results.

Box 19.1: Syphilitic stigmata

<i>Rhagdes</i>	Hutchinson triad
Saddle nose	1. Peg-shaped upper central incisors (only permanent)
Cranial bossing	2. Interstitial keratitis
Perforation of palate	3. Deafness
Sabre tibia	
Blindness	

Interstitial keratitis needs corticosteroid ophthalmic drops for adequate response.

Along with specific measures, patient's nutrition and superimposed infections should also be attended to.

Prevention

Detection of the disease in the mothers, especially early in pregnancy, and its timely treatment is the most important aspect of prevention.

Prognosis

With adequate treatment, especially if instituted early, prognosis is excellent, except in cases of meningovascular syphilis, in interstitial keratitis and in the presence of severe infection in a newborn.

Delayed treatment may save the child but the incidence of stigmata is fairly high.

LEPTOSPIROSIS

Etiopathogenesis

It is a spirochete infection, finding entry into human through abrasions and cuts in skin or mucous membrane exposed to animal urine. Primarily, leptospira damage the endothelial lining of blood vessels, resulting in ischemic insult to liver, kidneys, meninges and muscles in particular (multiorgan involvement).

Clinical Features

After an incubation period of 7-12 days, septicemic phase sets in. During this phase of 2-7 days, organisms can be isolated from blood and CSF. Then, there is a brief period of wellbeing. This is followed by an immune phase (of several weeks) in which organisms disappear from blood and CSF and lodge in tissues. Circulating antibodies appear during this phase.

Leptospirosis may be asymptomatic (subclinical) or symptomatic. In symptomatic cases, onset is sudden, presenting as high fever (70%), aseptic meningitis (20%) or as hepatorenal dysfunction (10%). Mild disease is anicteric whereas severe disease is icteric (Weil's syndrome).

Diagnosis

Diagnosis is confirmed by serology (microscopic agglutination test).

Treatment

As soon as the diagnosis is suspected, treatment with parenteral penicillin G (alternatively, tetracycline) should be initiated.

Prevention

It is in the form of rodent control measures, avoidance of contaminated water and soil, and once a week doxycyclin to exposed subjects.

TUBERCULOSIS

Childhood tuberculosis, a chronic illness caused by *Mycobacterium tuberculosis*, is characterized by vague and protracted constitutional manifestations and a course that is marked by remissions and exacerbations. Except for a few cases of extrapulmonary tuberculosis caused by bovine type of mycobacterium, pediatric tuberculosis is caused by human type of mycobacterium. The topic is discussed in details in Chapter 21 (Pediatric Pulmonology).

MENINGOCOCCAL INFECTIONS

The gram-negative cocci, *Neisseria meningitidis*, a commensal in the nasopharynx of healthy individuals, may lead to disease, meningococemia-when the organisms invade the blood stream and disseminate to various parts. Various serotypes identified are types A, B, C, D, X, Y, Z, 29E and W135.

Ever since 1984, there has been outbreak of meningococemia in Delhi in particular followed by Uttar Pradesh, Rajasthan, Haryana, Jammu & Kashmir, West Bengal, Sikkim and Gujarat. The outbreak is now on decline. Serogroup A is responsible for the disease in India. Moreover, the predominance of the cases is during January through May. The disease is seen over twice as often in males as in females.

Pathogenesis

The cell wall of the organism contains lipopoly-saccharide, an endotoxin responsible for such serious manifestations as systemic toxemia, peripheral circulatory failure and DIC. Bleeding into the adrenals occurs in subjects with septicemia and shock (*Waterhouse-Friderichsen syndrome*).

Nasopharynx is the primary focus of infection, the person to person spread occurring through respiratory droplet infection or close oral contact. Hematogenous-spread occurs when the cocci penetrate the mucosa and are disseminated by leukocytes to blood stream.

Factors that render a host susceptible to meningococemia include deficiency of terminal components (C5 through C9) of the complement system, existing complement-depleting disease, inherited deficiency of an alternative complement pathway component, properdin, presence of B27 histocompatibility leukocyte antigen complex, deficiency of IgG₂ subclass, and sickle-cell disease.

Factors that heighten susceptibility of the host to systemic spread include extremes of climate and damage to nasopharyngeal mucosa by a viral infection such as influenza.

Clinical Features

Incubation period is 2 to 10 days.

Various modes of presentation of meningococcal infection are:

Upper respiratory infection with or without bacteremia is a self-limited common cold-like illness that resolves within a few days. Only in a small proportion of the cases maculopapular rash may occur. Occasionally, conjunctivitis, cervicitis or urethritis may occur. This is also called "surface disease".

Acute meningococemia manifests as influenza like illness with fever, malaise, myalgia, headache and GIT upset followed by a rash (morbilliform, petechial or purpuric)—the hallmark of the disease—hypotension, DIC, oliguria with progressive renal failure, and coma. Most often the course is nonfulminant but it may be fulminant with extensive purpura, hematogenous dissemination and shock which may not respond to treatment (Fig. 19.4).



Fig. 19.4: *Meningococemia*. Note the petechial and purpuric spots

Meningococcal meningitis results from hematogenous spread to meninges and is characterized by such manifestations of meningeal irritation as progressive drowsiness, vomiting, neck stiffness, and convulsions. Unlike very high incidence of meningitis in adult meningococcal infection, only one-half of the children suffer from this complication.

Acute endocarditis, myocarditis, pericarditis and pneumonia may be associated with meningococemia, Vulvovaginitis, urethritis, pelvic inflammation and endophthalmitis are rare complications.

Chronic meningococemia is characterized by anorexia, weight loss, pyrexia with chills, rash arthritis/arthritis, erythema nodosum and endocarditis. It is rare in children and has periods of exacerbations and remissions, the course lasting for weeks to months.

Diagnosis

High index of suspicion goes a long way in identifying cases of meningococcal infection.

- Culture from nasopharynx leading to isolation of meningococci provides presumptive evidence of infection.
- Petechial skin lesions may be lanced (punctured) and smeared to see gram-negative diplococci after Giemsa or Gram stain.
- Blood: Smear and culture.
- CSF: This investigation is a must in all cases suspected of meningitis. Biochemistry and morphologic picture is that of any pyogenic meningitis. Gram staining and culture may be positive.
- Rapid diagnostic tests include countercurrent immunoelectrophoresis, latex agglutination, radioimmunoassay on blood, CSF and urine, limulus lysate assay and Quilling reaction.

Treatment

The drug of choice is penicillin G, 3 lakh units/kg/day, administered intravenously in 6 divided doses. If exact etiology is not established, ampicillin may be given intravenously in a dose of 300 mg/kg/day in 6 divided doses. In case of penicillin allergy, chloramphenicol, 100 mg/kg/day, intravenously in 4 divided doses, cefotaxime, 200 mg/kg/day in 6 hourly doses intravenously or ceftriaxone 100 to 150 mg/kg/day, intravenously, may be employed.

Therapy must be continued for at least 7 to 10 days and until the patient is afebrile for at least 3 days in case of simple meningococemia and 5 days in case of meningitis.

For endotoxemic shock, dopamine (initial dose 2 to 5 mcg/kg/min; then increased till blood pressure and urine output are satisfactory to as much as 20 mcg/kg/min (if the need be) and/or steroids (hydrocortisone or dexamethasone) are indicated.

For DIC, fresh whole blood, fresh plasma or platelets as such or together with heparinization may be helpful.

3

Prognosis

Overall mortality from meningococcal disease varies from 3 to 20%, the lower figure being for meningitis. Poor prognostic signs are:

- Hypotension
- Absence of meningitis
- Coma
- Rapidly progressive purpura, especially of less than 24 hours duration
- Hyperpyrexia
- Cardiac or renal failure
- DIC
- Leukopenia, thrombocytopenia, low ESR and high serum antigen concentration
- Low CSF polymorphonuclear leukocyte count

Long-term sequelae include sensorineural deafness and psychomotor disability.

Prevention

Chemoprophylaxis This is indicated in household and day-care nursery contacts of an index case as per Table 19.12.

Vaccination Indian meningococcal infections are caused by group A strains for which an effective vaccine is available. It is recommended for household and day-care nursery contacts of an index case as an adjunct to chemoprophylaxis. A single dose is effective, taking about 2 weeks to act. Booster doses after 3 months and 12 to 18 months are said to provide additional protection.

Use of meningococcal vaccine for normal children as a part of routine vaccination is not recommended. Also, see Chapter 10 (Immunization).

Table 19.12: Chemoprophylaxis in meningococcal infections

Drugs	Doses	Durations
Rifampicin (Drug of choice)	10 mg/kg (O) (maximum of 600 mg) 12 hourly	48 hours
Sulfisoxazole or Sulfadiazine	Under 1 year 500 mg BD 1 to 12 year 500 mg BD 12 years and above IgBD	48 hours
Ceftriaxone	125 mg (single dose, once only)	
Ciprofloxacin	500 mg BD	5 days

HELICOBACTER PYLORI (*H. PYLORI*) INFECTION

That infection with *H. pylori* is an important cause of morbidity related to the upper GIT, especially stomach and duodenum, even in pediatric population of under-privileged communities is a recent realization. The topic is discussed in Chapter 24 (Pediatric Gastroenterology).

ANAEROBIC INFECTIONS

Etiopathogenesis

Anaerobic bacteria are agents that poorly tolerate oxygen. Two types are known:

1. **Obligate:** They fail to grow on blood agar plate incubated aerobically, even when generous supply of carbon dioxide made available.
2. **Facultative:** They manage to survive in the presence of oxygen. Their growth is, however, better when the oxygen supply is reduced. These bacteria form a part of normal human flora, particularly in the buccal cavity, GIT, vagina and skin. There is distinct predominance of obligate anaerobes.

Anaerobes may be categorized as follows:

1. Bacilli
 - Gram +ve
 - a. Spore-forming: *Clostridium tetani*, *Clostridium perfringens*, *Clostridium botulinum*, *Clostridium novyi*, *Clostridium septicum*, *Clostridium ramosum*.
 - b. Nonspore-forming: *Lactobacillus*, *Bifidobacterium*, *Arachnia Enbacterium*, *Propionibacterium*.

Gram -ve (only nonspore-forming)

- a. Bacteroids: *B. fragilis*, *B. oralis*, *B. melaninogenicus*, *B. Carrodens*.
- b. Fusobacterium: *f. nucleatum*, *F. vanum*, *F. necrophorum*, *F. mortiferum*.

2. Cocci

Gram +ve

Peptococcus, *Peptostreptococcus*, *microaerophilic cocci*.

Gram -ve

Veillonella, *Acid aminococcus*, *Megasphaera*. Infection with anaerobes may occur by any of the following mechanisms:

1. Aerobes destroying healthy tissue, thereby making the previously well-oxygenated healthy sites vulnerable to establishment of anaerobic infection.
2. Removal of oxygen or addition of reducing substances, thereby reducing the oxygen-reduction potential.
3. Removal of aerobes.

The major pathologic findings in anaerobic infection consists of abscess formation and widespread tissue destruction.

Clinical Features

Anaerobic infection of the upper respiratory tract usually takes the form of periodontal inflammation, periapical abscess, osteomyelitis of mandible or maxilla, chronic sinusitis, otitis media, mastoiditis, peritonsillar or retropharyngeal abscess, parotitis, cervical adenitis, etc. In *Vincent angina* and *Ludwig angina*, anaerobes (*Fusobacteria*) are particularly important.

Anaerobic infection of the lower respiratory tract may present as necrotizing pneumonia, putrid empyema or lung abscess.

Anaerobic infection of the CNS usually manifests as brain abscess, subdural empyema, or septic thrombophlebitis of venous sinuses or cortical veins.

Anaerobic infection of the GIT (usually lower) presents in the form of manifestations which depend upon the nature of the primary lesion as also on the subsequent localization of disease process.

Manifestations of anaerobic septicemia include pyrexia, jaundice, hemolytic anemia, and shock. There is leukocytosis.

Other manifestations of anaerobic infection include septic arthritis, osteomyelitis, UTI, liver and subphrenic abscess adenitis, and involvement of soft tissue and skin.

Finally, remember that any part of the body may be involved by anaerobic infections.

Diagnosis

Anaerobic infection may be anticipated in the following situations.

1. Birth after prolonged rupture of membranes, amnionitis or obstetrical delivery (*neonatal anaerobic infection*).
2. Peritonitis or septicemia associated with intestinal obstruction or perforation, appendicitis, cholecystitis, or gastroenteritis.
3. Congenital or acquired disorders in which response to infection is impaired. Clinical clues to anaerobic infection include foul smelling discharge, necrosis, gangrene, infection close to mucosal surface, endocarditis with negative blood cultures, septic thrombophlebitis, or obscure icterus with bacteremia. Also important are such clues as infection that persists or follows prolonged use of gentamicin or other aminoglycosides, infection with tissue destruction as in injury or malignancy, or infection after human or dog (in fact, any animal) bite.

Definite diagnosis is by cultures from the infected site.

For rapid diagnosis, immunofluorescence assay or gas liquid chromatography of purulent material may be done.

Treatment

Pending results of culture and sensitivity, an appropriate therapy must be started, depending upon the type of anaerobic infection that can generally be predicted from the site of infection.

A combination of penicillin with chloramphenicol suffices in most situations. Addition of metronidazole (O, IV) is claimed to yield still better results.

Table 19.13 gives the pattern of activity of various antimicrobial in anaerobic infections.

Table 19.14 gives recommendations on use of *antimicrobials* in various anaerobic infections based on site of infection, epidemiology and sensitivity pattern.

Aminoglycosides, cephalosporins and quinolones are ineffective against anaerobes. Penicillin is ineffective in *B. fragilis* which is an important anaerobe not only in infections below the diaphragm but also in 15 to 25% of lower respiratory infections.

Table 19.13: Range of activity of antimicrobials in anaerobic infections

Range of activity	Antimicrobials
Nearly always active	Metronidazole (except in actinomyces), chloramphenicol, beta-lactamase antibiotics combined with beta-lactamase inhibitors (ticarcillin, ampicillin, sulbactam, clavulanic acid)
Usually active	Clindamycin, cefoxitin, anti-Pseudomonas penicillins
Variably active	Penicillin, vancomycin

Table 19.14: Antimicrobials recommended for various anaerobic infections

Infection according to site	Recommended antimicrobial agent (s)
Orofacial	High dose IV penicillin
Pleuropulmonary	Clindamycin
Peritonitis	Clindamycin, cefoxitin, metronidazole
Brain abscess	Metronidazole, chloramphenicol
Salpingitis	Cefoxitin
Tuboovarian abscess	Clindamycin, metronidazole, or cefoxitin

Besides, antimicrobial therapy, approach to therapy in anaerobic infections must address to debridement, resection, aspiration, and drainage of cavities containing septic material.

Prognosis

It depends on type of disease with anaerobic infection, rapidity with which appropriate therapy is started and age of the patient. Mortality is relatively higher in subjects suffering from extensive tissue necrosis with inadequate debridement or necrotizing enterocolitis, and in newborns. In the neonates, 15 to 20% mortality occurs.

OPPORTUNISTIC INFECTIONS

These include:

1. Infections due to ordinarily nonpathogenic bacteria or fungi, and
2. Unusual clinical infections with common pathogens.

In Normal Host

Saprophytic microorganisms that form the indigenous flora of the host, or are commonly associated with

the neonatal period may turn opportunistic causing clinical infection in normal, healthy infants and children.

Examples:

- | | |
|--------------------------|---|
| <i>Bacteroids</i> | – abscesses, septicemia, peritonitis |
| <i>Bacillus subtilis</i> | – abscess, cellulitis, conjunctivitis, septicemia |
| <i>Diphtheroids</i> | – endocarditis, meningitis |
| <i>Lactobacillus</i> | – lung abscess |

In Susceptible Host

Derangement of the host defence as a result of an identifiable congenital, acquired or environmental defect.

I. Host compromised by changes in the skin or mucous membranes, or by anatomic defect.

Here the barriers to infection are bypassed or compromised, producing conducive environment for opportunistic infections.

In various *shunts* (CSF, renal dialysis), opportunistic organisms mostly isolated are *Staphylococcus epidermidis*, *Staphylococcus aureus*, *Bacillus Sp.*, and diphtheroids. Manifestations include fever, erythema around the tubing employed for shunt, and hypocomplementemic glomerulonephritis. Treatment, pending sensitivity report, should be with penicillin and chloramphenicol, or chloramphenicol and a cephalosporin, together with removal of the shunt in majority of the cases.

Intravenous catheterization, particularly for total parenteral nutrition, may cause local thrombophlebitis, bacteremia or fungemia by opportunistic organisms such as *Staphylococcus epidermidis*, *Bacteroids*, *Mimeae*, *Pseudomonas*, *Candida* and *Cryptococcus*. If clinical signs and positive cultures persist, suitable antibiotic therapy should be instituted.

Use of "inhalation therapy equipment", especially in newborns, may lead to infection with such opportunistic organisms as *Pseudomonas* and *Serratia*.

Urethral catheterization may predispose an individual to opportunistic infection of the urinary tract with *Pseudomonas sp*, *Serratia*, *Herellea*, *Staphylococcus epidermidis* or *Candida*.

Burns may lead to opportunistic infection with *Pseudomonas*, *Serratia*, *Staphylococcus*, *Candida* or *Mucor*. The possible causes include change in ecology of skin flora and physiochemical properties of skin,

neutrophil dysfunction, abnormal responses to antigenic stimulation, impairment of delayed hypersensitivity, long-term administration of antibiotics and prolonged intravenous or urethral catheterization.

Dermal sinus tracts that communicate with neural tissue or subarachnoid space may lead to meningitis with such organisms as *Staphylococcus epidermidis* or *diphtheroids*.

Cardiac defects (both congenital and acquired) predispose the damage tissue to act as nidus for opportunistic infection with *Streptococcus viridans*, *Coryne-bacterium*, *Pseudomonas*, or nonpathogenic *Neisseria*.

Surgery, especially cardiac surgery predisposes to infection because of prophylactic use of antibiotics which alter the normal flora or nidus of infection provided by foreign bodies inserted. *Staphylococcus epidermidis*, *Diphtheroids*, *Mimeae*, *Pseudomonas*, *Candida*, and *Aspergillus* are the opportunistic organisms that may produce disease.

II. Host compromised by inherited/acquired defects affecting defense

B-cell defects are frequently accompanied by recurrent infections, often due to opportunistic organisms such as bacterial pathogens and *Pseudomonas*. Treatment consists in giving gamma globulin 1.4 ml/kg (IM), drainage of abscess if present and antibiotic therapy depending upon the etiologic agent. Prevention consists in giving gamma globulin 0.7 ml/kg/month (IM), vigorous attention to postural drainage in chronic respiratory disease, and prophylactic use of penicillin or ampicillin in selected cases demonstrating recurrent middle ear or lung problem. *T-cell defects* also are often complicated by recurrent opportunistic infections with *Mycobacterium*, *Listeria*, *Nocardia*, cytomegalovirus, varicella, *Cryptococcus*, *Candida*, *Pneumocystis*, and *Strongyloids stercoralis*. Treatment consist in giving a narrow-spectrum antimicrobial (depending on the responsible agent) application of topical and nonabsorbable antimicrobial agent and incision and drainage of abscess, if any. Prevention consists in prophylactic administration of cotrimoxazole for prevention of *Pneumocystis carinii* pneumonia, protective environments for certain patients, oral nonabsorbable antimicrobial agents to lower concentration of GIT flora, and careful screening for tuberculosis. No live vaccine should be given to these patients.

Combined immunodeficiency syndromes are also vulnerable to opportunistic infections with such organisms as bacteria, fungi, viruses and pneumocystis. In addition to gammaglobulin, all the therapeutic and preventive measures required in T-cell defects are indicated in these patients too.

In *immunosuppression* resulting from drug therapy, infection with aerobic gram-negative organisms occurs more commonly and may cause significant morbidity and *Pseudomonas*, *Klebsiella*, *Escherichia coli*, *Herellea*, *Serratia*, herpes simplex, Varicella zoster, cytomegalo-virus, EB virus, papovirus, hepatitis virus, *Candida*, *Aspergillus*, *Mucor* and *Cryptococcus*.

Transplantation may *per se* predispose the host to infection and also through use of immunosuppressive therapy. Opportunistic organisms isolated usually include *Staphylococcus*, *Pseudomonas*, *Klebsiella*, *Candida*, *Aspergillus*, *Nocardia*, *Pneumocystis*, *Cytomegalovirus*, hepatitis virus, herpes simplex, and varicella zoster.

Malignancy is often complicated by infection which may prove a terminal event. Opportunistic organisms in malignancy include *Pseudomonas*, *Klebsiella*, *Escherichia coli*, *Listeria*, *Mycobacterium*. Probable mechanisms include granulocytopenia, reduced chemotaxis, reduced bacterial activity of neutrophils, lymphopenia, defective cellular response, and defective antigenic response to challenge.

Malnutrition renders the host vulnerable to opportunistic infection with organisms such as measles virus, herpes or varicella zoster virus and *Mycobacterium*. The susceptibility is attributed to impaired T-cell function, reduction in complement activity, impaired migration of phagocytes and reduced bactericidal activity.

Collagen diseases are frequently complicated by infections with *Candida*, *Mucor*, *Aspergillus*, *Pneumocystis*, *Diphtheroids*, *Listeria*, *Serratia*, *Staphylococcus*, *Nocardia*, *Cytomegalovirus*, herpesvirus, varicella-zoster, etc. Host defence is reduce because of involvement of reticuloendothelial system and use of immunosuppressive agents (Table 19.15).

NOSOCOMIAL INFECTIONS

Also termed *hospital-acquired infections*, these are infections which develop within the hospital or are produced by microorganisms acquired during hospitalization. These may afflict not only the patients but also staff members, volunteers, visitors,

Table 19.15: Microbial pattern of pediatric malignancy

Clinical situation	Common microbial pattern
Fever due to septicemia in ALL	Gram-negative organisms
Protracted fever in ALL during relapse	Fungal organisms
Infection in CLL	Gram-positive organisms
Infection in multiple myeloma	Gram-positive organisms
Infection in CLL and multiple myeloma with neutropenia	Gram-negative organisms
Infection in Hodgkin lymphoma	<i>Listeria, Salmonella, Brucella, Mycobacteria, Cryptococcus, Pneumocystis carinii</i>

attendants, etc. having contact with the hospital. Some of the affected individuals may manifest symptoms after discharge from the hospital, e.g. hepatitis B and some other infections of the newborn.

Etiologic Considerations

All infections in newborns delivered in the hospital need to be considered “acquired” except those caused by organisms reaching the baby from the mother at or before the time of birth. This is true in early onset of systemic sepsis caused by *E. coli*, Streptococci Group B, *Listeria monocytogenes*, etc.

Congenital infection can be due to Cytomegalic virus and toxoplasma. Eye infections may be due to *Gonococcus* and *Chlamydiae*. Septicemia and meningitis are quite common in first week of life.

Measures employed to increase the survival rate in small babies have added greatly to the risks of nosocomial infections, e.g. IV drip, assisted respiration, parenteral nutrition, lavish use of broad spectrum antibiotics, and extensive surgical maneuvers on babies with congenital malformations. Sepsis rate in neonatal intensive care unit (NICU) is among the highest anywhere in the hospital.

Infections appearing after first few days of life are predominantly caused by enterobacteria, *Pseudomonas aeruginosa* and other nonfermenters. *Flavobacterium meningosepticum* and *Citrobacter koseri*, however, appear to cause meningitis in the newborn. Stay of the neonate in the hospital for more than a week is likely to lead to Staphylococcal skin infection of both vesicular and pustular type. It often occurs in

epidemics associated with single strain of *Staphylococcus aureus*.

During last over two decades neonatal necrotizing enterocolitis has come to be recognized as an important hazard to the lives of premature babies in special care neonatal unit (SCNU). The condition does not start until oral feeding is initiated. According to a hypothesis, hygienic precautions taken in SCNU tend to lead to homogeneity in the gut flora in which only one or very few bacterial strains may multiply unchecked during first few days of life.

Diarrheal disease of the newborn may be caused by *E. coli*, *Salmonella*, *Vibrio cholerae*, *Shigella*, *Campylobacter*, rotavirus, etc.

According to one report of infection with *M. tuberculosis*, babies born in obstetric unit had converted to tuberculin positive at an extraordinarily high rate. This could only be explained by acquisition of hospital infection.

The other organisms causing neonatal nosocomial infections are *Bordetella pertussis*, *H. influenzae*, *Corynebacterium diphtheriae*, *Cl. tetani*, *H. influenzae*, virus (A, B, non-A-non-B), rubella, influenza, respiratory syncytial, *Candida*, *Mucor*, *Pneumocystis carinii*.

Mode of Transmission

- Contact spread** Contact with a number of contaminated inanimate objects serves as a source of transmission of nosocomial infections in children, e.g. rectal thermometer, feeding bottle, nipples, aspiration and suction material and equipment, disinfectants, venous and arterial catheters, renal dialysers, etc.
- Common vehicle spread** Here contaminated inanimate vehicle serves as the vector for transmission of infectious agent to multiple individuals, e.g. infected food, blood and its products, IV fluids, etc.
- Airborne spread** This involves an organism that has a true airborne phase in its route of dissemination which usually involves a distance of more than several feet between the source and the victim, e.g. tuberculosis, *Staphylococcus* infection, salmonellosis, etc.
- Vector-borne Spread** Vector-borne transmissions, both external and internal, can cause nosocomial infections. By external vector-borne transmission is meant mechanical transfer of microorganisms

on body or appendages of the vector, e.g. *Shigella* and *Salmonella* which spread in this way through flies. Internal vector-borne transmission includes harborage (*Yersinia pestis*) and biologic transmission (malarial parasite).

Common Nosocomial Infections

1. Lower respiratory tract infection, e.g. pneumonia, pulmonary tuberculosis, pulmonary aspergillosis, *Chlamydia*, *Pneumocystis carinii*, etc.
2. Surgical wound infection following diagnostic and therapeutic procedures, e.g. urinary tract catheterization or instrumentation, tracheostomy, continuous IV therapy, surgical wounds, etc. Pathogens of wound infection are *Staphylococcus aureus*, *E. coli*, *Pseudomonas aeruginosa*, *Proteus*, *Bacteroides*, etc.
3. Gastroenteritis. Organisms responsible are *Shigella*, *Salmonella*, rotavirus, *Yersinia*, *Vibrio cholerae*, *Campylobacter*, *Clostridium difficile*.
4. Intravenous cannula-associated infections. Organisms responsible are *Klebsiella*, *Staphylococcus aureus*, *Citrobacter*, *Candida albicans*, etc.

Investigations

1. Nose and throat swabs of all contacts must be processed.
2. Skin swabs from suspected carriers should be rubbed over the chosen site.
3. Floor, furniture, baths, operations, tables, a moistened swab, etc., may also be source of infection. Hence, a moistened swab is rubbed over wide area of the surface and then seeded on blood agar or appropriate selective media.
4. Textile, linen, cotton and dressing may harbor pathogens capable of causing hospital infection. Small portion of each of them, if available, may be dipped into bottles containing broth and cooked meat broth.
5. Exposure of blood agar plates in pairs at various sites in the operation theater to find risk of aerial contamination of wounds.

Preventive and Control Measures

A. Specific

1. Provision of graded care facilities, including an observation unit, an intensive care unit and an intermediate care or long-term growth unit.

2. Infants with infections that can spread by airborne route must be separated from other infants, preferably out of nursery area.
3. Use of prophylactic antibiotics in high risk infants, especially with respiratory support and endotracheal intubation.
4. Surveillance program, using multiple techniques to detect infection and related problems within a nursery and to detect infection pattern, should be implemented.
5. Use of gowns, caps and masks.*
6. Proper hand washing.*
7. Critical evaluation of new procedures and techniques into the nursery, e.g. *Staphylococcus enterocolitis* in infants having indwelling nasoduodenal feeding catheter passed through nares are colonized with *Staphylococcus aureus*.

B. General

1. As far as possible, provision of separate cubicle type space for each patient with barrier nursing should be provided. Glass pane partition is usually adequate.
2. Division of the ward into sections with clean and septic cases kept separately in groups.
3. Highly infectious cases such as measles, pertussis, etc. should be kept in isolation rooms.
4. Each section should have facilities for intensive care and resuscitation so that undue movement of equipment or patient himself from one section to another can be avoided.
5. It is better to have wheel cots so that the entire cot and patient rather than only the patient can be moved if required. It should be the policy to retain the same cot during the whole hospital stay of the child. If possible, the cot should be washed with soap and water and carbolyzed with phenol after the patient is discharged. Bed sheet, pillow cover, etc. also need to be treated in this way. A pottie with opened plastic bag should be provided with each cot.
6. Ward floor, toilet, wash basins, sinks, etc. need to be kept clean by frequent washing, etc. It is better to have foot-operated taps and two-way swing doors to prevent frequent touching.

* There is evidence that, if compliance regarding proper hand washing becomes 100%, gowns, caps and masks may not be needed

7. Health education session for the parents/ attendants as also for the staff.

NOMA (*Cancrum Oris, Gangrenous Stomatitis*)

This uncommon condition refers to a progressive gangrene of the buccal mucosa following its invasion by anaerobic micro-organisms (say fusco-spirochetal bacteria). Nearly always, a perforating ulcer of the cheek results (Fig. 19.5).

Poor body resistance as in chronic debilitating disease or malnutrition predisposes to the disease.

Therapy chiefly consists of intensive antibiotic cover, nutritional rehabilitation, and, if the need arises, plastic surgery later.

TOXIC SHOCK SYNDROME (TSS)

This, a recently recognized serious condition, is characterized by sudden onset of high fever, vomiting, diarrhea, abdominal pain, sore throat, headache, diffuse myalgia, erythematous (macular) rash, mucosal hyperemia, hypotension, oliguria and change in sensorium. DIC may occur.

The disease, involving multiorgan systems, predominantly occurs in menstruating women (15 to 25 years of age) who use highly absorbent “tampons” continuously throughout the “period”. At times, it may occur in children, nonmenstruating women, and men secondary to such conditions as pneumonia, sinusitis, empyema, tracheitis, abscesses, osteomyelitis, bacteremia, wounds, nasal packing, etc.



Fig. 19.5: Noma (cancrum oris, gangrenous stomatitis)

Recurrence rate in menstrual TSS within 3 months of the primary episode is around 30% without appropriate antimicrobial therapy.

A toxic shock syndrome toxin (TSST-I) produced by *Staphylococcus aureus* strain (phage type 29/52) plus some unrecognized toxins are supposed to play role in its causation. TSST-I is known to cause grave fluid loss either directly or through production of interleukin-1 and tumor necrosis factor.

Diagnosis of TSS is based on certain criteria (Table 19.16). TSS is probable in the presence of over 3 criteria with desquamation, or when over 5 criteria are satisfied in the absence of desquamation.

Differential diagnosis is chiefly from mucocutaneous lymph node syndrome, the so-called *Kawasaki disease*. The latter disease occurs usually in children under 5 years of age. Vomiting, diarrhea, abdominal pain, myalgia, and shock are absent. Rocky Mountain spotted fever, leptospirosis, measles, scarlet fever, septicemia and toxic epidermal necrolysis also need consideration in the differential diagnosis.

Prevention consists in avoiding use of tampons, not using high-absorbent tampons, or using them intermittently during each “period”.

Management consists in giving IV fluids and a suitable antibiotic that can resist beta-lactamase staphylococci (say methicillin, oxacillin or nafcillin). In case of allergy to penicillin, a substitute agent (clindamycin, erythromycin, rifampicin or cotrimoxazole) may be employed. Interestingly, chemotherapy prevents

Table 19.16: Diagnostic criteria for TSS

Pyrexia (over 38.9°C)

Rash (diffuse macular erythroderma) with desquamation 1 to 2 weeks after onset of illness, particularly involving palms and soles. Hypotension (systolic BP under 90 mmHg in adults, or under 5th percentile for age in children under 16 years), or orthostatic syncope.

Involvement of 3 or more of the following organ systems:

- GIT: vomiting, diarrhea
- Muscular: Severe myalgia, high creatine kinase level
- GUS: High blood urea nitrogen, serum creatinine, leukocytosis in the absence of UTI
- Liver: High total bilirubin, serum AST, ALT
- Hematology: Reduced platelet count
- CNS: Change in sensorium, disorientation without focal neurologic signs when pyrexia and hypotension are absent

Negative results on the following tests:
Serologic tests for Rocky Mountain spotted fever, leptospirosis and measles.

recurrence rather than influence the immediate clinical profile in menstrual TSS. In case of female patients, any retained tampons must be removed.

Recovery takes 7 to 10 days to occur. It is accompanied by skin desquamation and, at times, loss of hair and nail.

Recovery rate is high—on an average 30%. Mortality is almost 8%.

FURTHER READING

Articles/Chapters

1. Aoyama T. Clarithromycin and azithromycin in pertussis. *J Pediatr* 1996;129:761.
2. Bhutta ZA. The challenge of multidrug resistant typhoid in childhood: current status and prospects for the future. *Indian J Pediatr* 1999;36:129.
3. Dayal R. Leprosy. In Gupte S (Ed): *Recent Advances in Pediatrics (Special Vol: Tropical Pediatrics-I)*. New Delhi: Jaypee 1998.
4. Dumbler JS. Rickettsial infections. In Behrman RE, Kliegman RM, Jenson HB (Eds): *Nelson Textbook of Pediatrics, (17th edn)*. Philadelphia: Saunders 2004:999.
5. Jacob John T. Immunization dialogue: Typhoid vaccination after enteric fever. *Indian Pediatr* 1999;36:724.
6. Long SS. Pertussis (*Bordetella pertussis* and *B. parapertussis*). In Behrman RE, Kliegman RM, Jenson HB (Eds): *Nelson Textbook of Pediatrics, (17th edn)*. Philadelphia: WB Saunders 2004:908.
7. Phuong CYT, Kneen R, Anii NT. A comparative study of ofloxacin and cefixime for treatment of typhoid fever in children. *J Pediatr Infec Dis* 1999;18:245.
8. Singh UK, Sinha RK, Prasad B, Chakrabarti B, Sharma SK. Ciprofloxacin in children: is arthropathy a limitation? *Indian J Pediatr* 2000;67:386.

Books/Monographs

1. Kelly E. *Pediatric Infections*. Boston: Academics 2000.
2. Kelly E, Kelly JE. *Infectious Diseases*. Boston: Academics 2007.



Pediatric Parasitosis

Suraj Gupte, Utpal Kant Singh

MALARIA

Malaria (*mala* meaning bad and *aria* meaning air) is a protozoal infection, characterized by recurrent fever, splenomegaly and anemia. It is the most persistent, the most destructive, the most widespread and the most difficult to control among all the tropical ailments. Until the beginning of 1970s it had virtually disappeared from India. Thanks to the National Malaria Eradication Program and WHO's War against it! It is a pity that ever since 1971 it has returned to India and other SE Asian countries with a big bang.

Life Cycle of Malarial Parasite

Pre-erythrocytic (hepatic or tissue) phase follows the bite. Within 30 minutes, the sporozoites move from blood into the liver and the reticuloendothelial tissue. Those escaping destruction by phagocytes reach the hepatocytes where they undergo an asexual reproduction. Over a variable number of days (8 and 5.5 in *P. vivax* and *P. falciparum*, respectively), thousands of merozoites are formed in the hepatic or tissue schizont which then ruptures to release merozoites into the circulation. In this phase (in other words the "incubation period"), the subject is asymptomatic.

Erythrocytic phase starts with the invasion of erythrocytes by merozoites. The merozoite once within the erythrocyte is called trophozoite which takes the shape of a signet ring. The latter transforms to an ameboid form. Then, there is a dividing stage (erythrocytic schizont) in which the nucleus of the ameboid form divides into 20 or more merozoites. The infected erythrocyte finally ruptures, releasing

merozoites into the circulation. These merozoites are capable of invading fresh erythrocytes and causing further cycle. In this phase, the subject becomes symptomatic with paroxysms of high pyrexia. The pigmentation of various organs, hyperplasia of reticuloendothelial system and late effects like anemia and fatty degeneration are the outstanding pathologic features of the disease.

Sexual reproduction follows when, after many stages of schizogony, some merozoites transform into sexual stages (the male microgametocytes and the female macrogametocytes) within the erythrocytes. When the patient is bitten by the female anopheles mosquito at this particular stage, it sucks the infected blood. In the mosquito's stomach, all forms except gametocytes get destroyed. As a result of some structural changes, the gametocytes become gametes. The male microgamete penetrates the female macrogamete. The fertilized macrogamete is called zygote. The zygote is called oocyte when it rests below the outer cell layer of the mosquito's stomach. When the oocyte ruptures, it releases sporozoites into the body cavity of the mosquito. On migration to the salivary glands, these sporozoites are ready to be released in the blood of the human host following the mosquito bite.

Epidemiology

Malaria is caused by the malarial parasite. Its four types in order of frequency of occurrence in India are: (i) *Plasmodium vivax*, (ii) *P. falciparum*, (iii) *P. malariae*, and (iv) *P. ovale*.

Transmission occurs through bite of female anopheles mosquito in which sexual cycle of the parasite is completed. Asexual cycle occurs in the humans.

The most common strain of malarial parasite responsible for the disease in India and most other tropical and subtropical countries is *P. vivax*. *P. falciparum* causes malignant tertian malaria unlike *P. vivax* which causes benign tertian disease. *P. ovale* and *P. malariae* clinically behave just like *P. falciparum*. *P. falciparum* is the dominant type in Africa and some parts of India. Humidity and rainfall increase the spread of the disease. An ideal of the magnitude of the problem of malaria in India can be had from the fact that about one-half of the patients in author's unit during July-August some years ago showed malarial parasite positive blood smears. Now the disease seems to be on decline once again though it continues to be responsible for significant morbidity and mortality in most parts of the country. Malaria shows peak prevalence in warm and humid environment. Maximum cases are, therefore, seen in July to November in India.

Most conducive sites for the parasite are stagnant water, pools, ponds, marshy areas, burrowed pits and poorly or unregulated irrigation channels.

Low plasma vitamin A status is associated with increased risk of *P. falciparum* parasitemia, leading to increased morbidity and mortality, perhaps by disruption of normal immunological function for which vitamin A is vital.

Higher the altitude, less the chance of malaria. Above 2000 meters altitude, it is infrequent to have this disease.

Certain hemoglobinopathies are protective and tends to be genetically selective in endemic malarious region. *P. falciparum* may fail to mature in children with sickle cell trait and *P. vivax* in those with thalassemia and enzyme deficiencies; G-6-PD deficiency. *P. falciparum* is unable to attain high density in children with G-6-PD deficiency.

In order to evaluate prevalence of malaria in a community, one or more of the following three epidemiological parameters may be applied:

- *Splenic index* is measured by the rate of palpability of spleen in the age group 2 to 10 years. The area is designated as "haloendemic" if the splenic rate is over 75%, as "hyperendemic" if the rate is over 50% and "low prevalence" if the rate is under 10%.

- *Parasitic rate* is the percentage of positive blood films in 2 to 10 year age group.
- *Proportionate case rate* is the number of clinically-diagnosed malaria cases for every 100 subjects examined in a clinic. This is merely a crude estimate of prevalence of malaria.

Host Response

The host initially responds to malarial infection by activating non-specific defence mechanism resulting in accelerated destruction of parasitized and non-parasitized erythrocytes. Those infected cells that escaped from splenic removal, are destroyed when schizont ruptures. The material released induces the activation of macrophages and release of cytokines which causes fever and exert other pathological effects. Temperature of 40 degrees Celsius are schizontocidal. In untreated infections, the effect is to synchronize the parasitic cycle with eventual production of the regular fever spikes and rigors that originally served to characterize the different malaria.

The specific immunity to malaria eventually controls the infection and confers protection from high level parasitemia and disease but not from infection. As a result asymptomatic parasitemia is common in older children living in holo or hyper endemic areas. Both cellular and humoral immunity are necessary but the exact mechanisms are not known. Immune children have a polyclonal increase in serum levels of IgM, IgG and IgA. Passively transferred IgG from immune individuals has been shown to reduce parasitemia in children and in infant up to one month.

Several factors delays the development of cellular immunity and include the absence of of major histocompatibility antigens on the surface of infected RBCs which preclude direct T-cell recognition; malaria antigen specific immune unresponsiveness and the strain diversity along with ability of the parasite to express immune dominant variant antigens on erythrocyte surface that change during the period of infection.

Pathogenesis

The pathological changes in malaria are mainly due to invasion of erythrocytes by parasites resulting in hemolysis. The hemolysis often leads to increase in serum bilirubin and sometimes is so severe particularly

in *P. falciparum*, to result in hemoglobinuria (Black water fever). Anemia is common and are mainly due to invasion and destruction of RBCs and partly due to dyserythropoiesis, quinine therapy and immune hemolysis. The released pigments accumulate in the reticuloendothelial cells of splenic follicles resulting in hyperplasia, in kuffer cells of liver, bone marrow brain and other organs. The deposition of pigment and hemosiderin results in slategray color of the organs.

In *P. falciparum* infections, sequestration of large number of parasites occurs in the venules and capillaries of various organs and lead to tissue dysfunction. Sequestration is due to ability of parasites to induce changes in erythrocyte surface causing to adhere to endothelial cells. Three receptors: ICAM-1, CD 36 and thrombospondin have been identified for parasitized erythrocytes and cause cerebral damage. Host cytokines also make endothelial cells more adhesive for the surface of parasitized red cells, thus augmenting sequestration. The large number of actively metabolizing parasites consume oxygen and glucose or produce toxic metabolites including lactate, that may affect cellular function. The sequestration also stimulates release of host transmitter including nitric oxide that may have a local effect on blood or the conduction of nerve impulses. Thrombocytopenia and spontaneous bleeding may occur and may be associated with DIC. The capillaries and mesangium of kidney contain deposits of immunoglobulins, complements and malarial antigens resulting in transient acute diffuse glomerulonephritis which usually resolve by appropriate antimalarial therapy.

Clinical Features

The clinical manifestations depend upon the type of infecting species and resistance or immunity of the host. High fever with headache, restlessness, anorexia, malaise, sweating, and failure to eat or drink are the most common mode of presentation in children. Chills and rigors, which are considered to be the hallmark of malaria in adults, are uncommonly encountered in infancy and early childhood. Also, even fever and other significant symptoms may be absent in some children with many parasites in their blood. Diarrhea, vomiting, pain abdomen, convulsions and even coma may be present in some of these children suffering from malaria. Progressive anemia and hepatosplenomegaly are invariably there, the enlargement of spleen being more predominant. Petechial

hemorrhage in skin or mucous membranes develop only rarely in severe falciparum malaria.

Neonatal malaria is uncommon in endemic areas because of the transplacental passage of maternal antibodies (IgG). When it occurs, the cause may be transfer of infection from mother (congenital malaria), an infected blood transfusion or natural infection.

In *falciparum* malaria presentations are similar to that caused by other species but complications are more common.

Severe malaria is the term applied to cases who have one or more of the features given in Table 20.1. The important manifestations of severe malaria in children are altered consciousness, labored breathing and severe anemia which may occur singly or in combination. Hypoglycemia may occur and is associated with increased mortality. Renal failure, pulmonary edema and DIC are less likely to develop in children.

Chronic malaria is the term applied to repeated attacks of malaria leading to growth retardation, anemia and hepatosplenomegaly.

Relapse is the term applied to recrudescence of pyrexia after a gap that is more than the normal periodicity of malarial pyrexia. Relapses are common in *P. vivax* infection but rare in *P. falciparum* infection which is devoid of exoerythrocytic phase.

Table 20.1: World Health Organization (WHO) guidelines for identifying severe malaria/complicated malaria

- More than 2% erythrocytes infected with malarial parasites
- Asexual parasite count 100,000/mm³ of blood
- High fever with body temperature 105°F (40.5°C) and above
- Severe anemia with hemoglobin under 5 g%
- Hematocrit (PCV) 30%
- Blood urea 55 mg
- Acute hepatopathy and clinically detectable jaundice
- Cerebral malaria (headache, mental disturbance, neurologic signs, convulsions, delirium, coma)
- Renal complications like acute renal failure, acute tubular necrosis, dark urine, etc.
- Hypoglycemia
- Noncardiogenic pulmonary edema, shock lung syndrome
- Hypovolemia, hypotension, feeble and rapid pulses, pale and clammy skin
- Cardiac dysrhythmias
- Secretory diarrhea and dysentery
- Splanchnic capillary blockade (melena)
- Other complications: Rupture of spleen, pyogenic pneumonia, miliary tuberculosis, septicemia, symptoms resembling hemolytic anemias

Complications

Cerebral Malaria

It is characterized by coma which cannot be explained by hypoglycemia or a transient postictal state and absence of other causative disease in a child with falciparum malaria. If untreated it is associated with death rate of approximately 20% in children. The onset may be gradual or sudden.

Majority of children have fever, irritability and listlessness prior to loss of consciousness. Convulsions are common and sometimes herald the onset of coma. Vomiting, cough and diarrhea may occur. Respiration is rapid; in some breathing is stertorous. Jaundice may be present. Liver may be moderately enlarged and spleen may be palpable. Some children may develop a shock like state with hypotension, cold extremities and a wide core to skin temperature difference.

In cerebral malaria, there is diffuse symmetric encephalopathy; focal neurological signs are unusual. Although some degree of resistance to head flexion may be present, signs of meningeal irritation are lacking. Eyes may be divergent and a pout reflex is common but other primitive reflexes are usually absent. Pupillary reflex and corneal reflex are preserved except in deep coma. Brain stem reflexes are also lost. Muscle tone may be either increased or decreased. Tendon reflexes are variable and planter reflexes may be flexor or extensor. Abdominal reflexes are invariably absent. Decerebrate or decorticate posture may be present. Patients may have retinal hemorrhages (15%). Less than 5% of patients have significant bleeding or other clinical evidence of DIC. Convulsion usually generalized and repeated are common. Approximately 10% of surviving children may have neurological deficit.

Hypoglycemia

It is common and associated with poor prognosis. It is due to failure of hepatic gluconeogenesis and increase in consumption of glucose by both host and parasites. Furthermore hypoglycemia is aggravated by quinine therapy. This manifests as sweating, breathlessness, tachycardia, deteriorating consciousness, seizures, extensor posturing, shock and coma.

Lactic acidosis commonly coexist with hypoglycemia in patients malaria. Anaerobic glycolysis in

tissues, lactate production by parasites and failure of hepatic lactate clearance are usual cause of lactic acidosis. Other contributory factors for acidosis are dehydration, shock, repeated seizures and hypoglycemia.

Noncardiogenic Pulmonary Edema

The exact cause of this is not known. It can be aggravated by vigorous administration of IV fluid and increased capillary pulmonary permeability. Manifestations are tachypnea, dyspnea and hypoxia.

Renal impairment is common with severe falciparum malaria. The exact pathogenesis is not known but may be related to sequestration of renal microcirculation with parasitized erythrocytes. The lesions resembles like ATN. Renal cortical necrosis never occurs. This is manifested as oliguria, anuria and increase in serum blood nitrogen and creatinine.

Coagulation Abnormalities

These are common in falciparum malaria. Less than 5% of patients with severe malaria have significant bleeding with evidence of DIC. Hematemesis, probably from stress ulcer or acute gastritis may also occur.

Aspiration pneumonitis following convulsion is an important cause of death in cerebral malaria. Malaria predisposes to bacterial superinfection possibly through its effect on immune response. Chest infections and catheter related UTI are common. Spontaneous gram-negative septicemia develops occasionally in severe malaria.

Black Water Fever

This is due to sudden, severe, massive, intravascular hemolysis and manifested clinically as passage of coca colored urine. The color of urine is due to hemoglobinuria. Renal failure may supervene. This condition occurs in children with G6PD deficiency. Hypersensitivity to antimalarial drug is the most likely cause.

Algid Malaria

Dehydration, gram-negative septicemia and, rarely, hemorrhage, may cause peripheral circulatory failure (shock) with cold clammy limbs.

Quartan Malarial/Nephropathy

Chronic or repeated infection with *P. malariae* may cause soluble immune complex injury to the renal glomeruli resulting in nephritic syndrome. The histopathological appearance is that of focal or segmental glomerulonephritis with splitting of the capillary basement membrane. Subendothelial dense deposits are seen on electron microscopy and immunofluorescence reveals deposits of complement and immunoglobulin (Ig3). The response to therapy is poor with either antimalarial agents or glucocorticoids and cytotoxic drugs.

Malaria related immunosuppression provokes infection with lymphoma virus; Epstein-Barr virus. Burkitt's lymphoma is strongly associated with this virus.

Tropical Splenomegaly

This is discussed *vide infra*.

Diagnosis

High degree of suspicion in children with the above clinical picture is of paramount importance in the diagnosis, especially in our set-up. In fact, it is a sound policy to exclude malaria in all cases of pyrexia of doubtful origin in the tropics. The differential diagnosis is usually from typhoid fever, tuberculosis, influenza, urinary tract infection, septicemia, liver abscess, hepatitis, etc.

The positive peripheral smear (thick for identifying the parasite and thin for recognizing its type) usually clinches the diagnosis. However, blood film for malaria parasite has a failure rate of a high magnitude since it is seldom repeated at intervals of 12 hours following the negative outcome of the film made at the peak of fever and since it is often not properly prepared and/or carefully examined.

Occasionally, bone marrow smear may be required when peripheral smear is negative but, yet, there remains a high suspicion of the disease.

Fluorescent antibody technique may be employed for detecting species specific IgG antibodies which are known to persist for many months after cure of malaria.

Other tests include:

- Quantitative buffy coat (QBC)
- Antigen-based tests
 - Dipstick antigen-capture assay
 - Optimal

- PCR
- Serology

Treatment

Specific treatment consists in administering the anti-malarial drugs as soon as possible after the diagnosis. The regimen recommended by the WHO and adopted by the *National Malaria Control Program* is given in Table 20.2.

The conventional regimen of administering chloroquine consists of 10 mg/kg (in terms of base) followed by 5 mg/kg 6 hours later. The dose of 5 mg/kg is again given on the second day as well as the third day. Alternatively, amodiaquine may be given in same dosage as in case of chloroquine. A combination of 500 mg sulfamethopyrazine (SMP) or sulfadoxine and 25 mg pyrimethamine, given in a dose of 25 mg/kg with reference to SMP or sulfadoxine, is recommended in resistant cases. Even cotrimoxazole may be employed in such cases.

Cases failing to respond to chloroquine and sulfa-pyrimethamine combination need to be treated with alternative drugs like mefloquine, artemisinin derivatives halofantrine or quinghosu which are, however, not yet freely available in India.

WHO now strongly recommends artemisinin-based combination therapy (ACT) in chloroquine-resistant malaria. In India, National Antimalaria Program has recommended ACT in the form of artesunate and

Table 20.2: Antimalarial drug regimen as recommended by the WHO and adopted by the National Malaria Control Program

Age (Years)	Chloroquine phosphate	Primaquine
0 to 1	1/2 tablet stat	Nil
1 to 4	1 tablet stat	2.5 mg
5 to 8	2 tablet stat	5.0 mg
9 to 12	3 tablet stat	10.0 mg
12 to 14 (including adults)	4 tablet stat	15.0 mg

Note: Each tablet of chloroquine phosphate provides 150 mg of the base. It requires to be given as a stat dose on first day only. Primaquine* is started on second day and given for a period of 5 days in cases where malarial parasite is demonstrated, provided that it is a case of *P. vivax* infection. The MP-positive case also needs one additional dose of chloroquine.

* Primaquine may result in hemolytic anemia in G-6-PD deficiency individual. It is, therefore, desirable (though not essential) to screen the patient for G-6-PD before administering this agent. The new drug, *balaquin*, is a safe alternative.

sulfadoxine-pyrimethamine for chloroquine resistant *P. falciparum* malaria.

In cerebral malaria, intramuscular chloroquine 5 mg/kg followed, if necessary, by another similar injection 6 hours later, was recommended until recently. For very rapid response, 1/10th of the intramuscular dose may be given as a bolus, highly diluted, in a very large syringe intravenously slowly. This is in addition to the intramuscular administration. Alternatively, total parenteral dose may be given in a drip in 6 hours. Remember, intravenous chloroquine may cause shock and even death.

Quinine infusion needs to be considered the therapy of choice in cerebral malaria today. The dose is 10 mg/kg. It should be dissolved in 200 ml of saline and given as IV drip slowly in 2 to 4 hours. This should be repeated 12 hourly until 6 to 8 doses are given. The occurrence of such reactions as convulsions, delirium, confusion, coma and hypotension is an indication for discontinuing the infusion.

Artemisinin derivatives (artemisinin, artesunate, artemether, artether) in injectable form are now a recommended treatment in severe/complicated malaria.

Artemether (Paluther) a semisynthetic derivative of artemisinin, has now emerged as the best drug for cerebral and other types of severe malaria. Its total dose is 9.6 mg/kg (IM)-3.2 mg/kg on first day and 1.6 mg/kg/day on subsequent 4 days. Alternatively, it may be given in the dose of 3.2 mg/kg/day on 3 successive days. Side-effects include nausea, vomiting, abdominal discomfort, reduced leukocyte and reticulocyte count, increased transaminases (ASAT, ALAT), bradycardia and arterioventricular block. The drug has a rapid onset of schizonticidal action, the parasite clearance time being 24 to 36 hours. It is available as 80 mg ampoules.

It is now recommended that antimalarial agents should be combined with artemisinin or its derivatives to protect against development of multidrug resistance (MDR) strains.

General measures include good nursing care, maintenance of adequate fluid and nutritional balance and use of antipyretics for fever and anticonvulsants for seizures. Treatment of anemia and other associated deficiencies must receive attention at the earliest. In order to reduce cerebral edema, it is advisable to give dexamethasone, 3 mg/kg intramuscularly every 6 hours. In case of acute renal failure, restriction of fluids,

salt and protein in diet is needed. Hemoglobinuria warrants injectable sodium bicarbonate for alkalinizing the urine as also blood transfusion for the accompanying anemia. In case of worsening renal failure, peritoneal dialysis is indicated.

Malaria Control/Prophylaxis

It includes:

- A. Case detection and treatment
- B. Mass drug administration
- C. Vector-control measures

The "Roll-back malaria initiative" (WHO, UNICEF, UNDD, World Bank), launched in 1998, is actively in operation in this behalf.

New/forthcoming antimalaria strategy includes:

- Malaria vaccines (under development)
- Gene therapy
- Gene mapping
- Low interleukin-12.

TROPICAL SPLENOMEGALY

This is characterized by massive splenomegaly, hepatomegaly, marked elevation in serum titers of IgM and malarial antibody, hepatic sinusoidal lymphocytosis and peripheral B-cell lymphocytosis.

Some children residing in hyperendemic or holoendemic region exhibit an abnormal immunological response to repeated infection. The chronic or repeated malarial infection produce hypergammaglobulinemia, normocytic, normochromic anemia and splenomegaly. This condition is associated with production of cytotoxic IgM antibodies to suppressor (CD8+) lymphocytes which leads to uninhibited B-cell production of IgM and formation of cryoglobulin (IgM aggregates and immune complexes). This immunological process stimulates reticuloendothelial hyperplasia and eventually produces splenomegaly.

Children usually present with an abdominal lump and rarely with abdominal pain suggesting perisplenitis. Anemia and some degree of pancytopenia are usually present but in majority of patients malarial parasites are not detectable in peripheral smear. Patients are susceptible to respiratory and skin infection. Antimalarial prophylaxis are recommended in children living in endemic areas. Patients who are refractory to prophylactic therapy, clonal lymphoproliferation may develop and later evolve into a malignant lymphoproliferative disorder.

Prognosis

It is generally good, provided treatment is initiated soon. In the absence of complications, it becomes difficult to predict the outcome. Malnutrition and other associated illness have adverse effect on prognosis. WHO guidelines of poor prognostic indicators are given in Table 20.3.

Prophylaxis

In the first place, it is important to control mosquito vector by measures including insecticides such as DDT.

Secondly, suppressive therapy with one or two tablets of chloroquine phosphate every week to all those exposed to malaria in endemic areas during epidemics is considered to be great assistance in prophylaxis.

Malaria vaccine is still in experimental stage.

Table 20.3: Clinical indicators of poor prognosis in malaria as per WHO

Clinical Indicators

Age under 3 years
 Deep coma
 Witnessed or reported convulsions
 Absent corneal reflex
 Decerebrate/decorticate rigidity
 Clinical signs of organ dysfunction (renal failure, pulmonary edema)
 Respiratory distress (acidosis)
 Circulatory collapse
 Papilledema and/or retinal edema

Laboratory Indicators

Hyperparasitemia (>250000/microliter or >5%)
 Peripheral schizotemia
 Peripheral blood polymorphonuclear leukocytosis (12000/cu mm)
 Mature pigmented parasites (>20% of parasites)
 Peripheral blood polymorphonuclear leukocytes with visible malarial pigment (5%)
 Packed cell volume less than 15% or Hb : <5%
 Blood glucose less than 2.2 m mol/L (40 mg/dl)
 Blood urea more than 60 mg/dl
 Serum creatinine more than 3.0 mg/dl
 High lactic acid (>6 m mol/L) low CSF glucose
 Raised venous lactic acid (>5 m mol/L)
 More than three fold elevation of serum enzymes (ALT,AST)
 Increased plasma 5'-nucleotidase
 Low antithrombin III levels
 Very high plasma concentrations of tumor necrosis factor (TNF)

KALA-AZAR (*Black-Sickness**)

A chronic febrile illness of protozoal etiology, characterized by irregular fever, hepatosplenomegaly, malnutrition and anemia.

Etiopathogenesis

The etiologic agent is a protozoal parasite, *Leishmania donovani*. Transmission occurs by the bite of sandfly. Parasitization of the reticuloendothelial system accounts for the salient features of the disease.

Epidemiology

Kala-azar is widely distributed in certain parts of the world. In India, it is endemic in Sikkim, Assam, Bengal, Bihar, Orissa, Tamil Nadu, Karnataka, coastline bordering the Bay of Bengal and some parts of Uttar Pradesh and Madhya Pradesh. Occasionally, it has been reported from north India as well. We have seen a few cases in Simla and Jammu.

Kala-azar does not usually occur above 600 meter altitude though there is documentation of a case from an area nearly 2,500 meters above sea level.

The disease is more or less confined to rural areas, especially those along rivers and lakes. Its epidemics are known to follow famine and war.

In recent years, kala-azar has shown a remarkable resurgence. In Bihar alone, the 1970 figure of 50,000 has shot up to approximately 300,000. Moreover, it no longer remains restricted to its known geographical belt, thereby altering its epidemiological scenario.

Clinical Features

The incubation period is 2 to 6 months. There may, however, be wide variations between 2 weeks to 2 years.

Three modes of onset of kala-azar are: insidious, typhoid-like and malaria-like. A large majority of the cases have insidious onset.

The clinical picture in the older children and infants differs considerably. Thus, two types are generally described: childhood type and infantile type.

I. *Childhood type*: It is seen in older children and resembles the adult type. Persistent, mild to moderate pyrexia with rapid enlargement of

* So termed because of the characteristic gray pigmentation of the skin seen in patients suffering from kala-azar

spleen in 2 weeks time is the characteristic feature; liver enlargement occurs rather slowly (Fig. 20.1). Malnutrition (with considerable weight loss) in association with pigmentation of skin and sparse, falling and brittle hair are the additional manifestations. Appetite is, however, good.

- II. *Infantile type*: Here, the onset is acute with high fever, rigors and vomiting. Lymphadenopathy and slight anasarca may be present. It is nearly always fatal.

Complications

The following serious complications may occur in kala-azar.

- Pneumonia
- Dysentery
- *Cancrum oris*: Also called *gangrenous stomatitis*, it is characterized by gangrene of the cheek and adjacent structures and is believed to be caused by an organism of the *Treponema vinceti* type. This particular organism is capable of producing rapid tissue destruction in a debilitated patient.
- Severe hemorrhage
- Agranulocytosis
- Jaundice
- Stomatitis
- Gingivitis.



Fig. 20.1: *Kala-azar*. Note the hepatosplenomegaly. The presentation was with prolonged pyrexia of several months duration

Diagnosis

The diagnosis of kala-azar is usually clear from the clinical picture. The chronic cases need to be differentiated from tropical splenomegaly, chronic malaria, brucellosis, Hodgkin disease, leukemia, tuberculosis, *Banti spleen* and hemolytic anemias. At times, cirrhosis and storage diseases also warrant exclusion.

When the onset is typhoid-like, kala-azar should be differentiated from enteric fever, septicemia, miliary tuberculosis, brucellosis and hepatic amebiasis.

Kala-azar with malaria-like onset needs differentiation from malaria, urinary tract infection, tuberculosis, etc.

Laboratory Diagnosis

The diagnosis of kala-azar is substantiated by direct demonstration of amastigote form of parasites in bone marrow, spleen, liver and lymph node aspirates or promastigote forms in culture of aspirated materials. The splenic aspiration and smear examination is the most sensitive (95%) but prior assessment of coagulation profile including platelet count and INR are essential as this procedure may lead to hemorrhage in and around spleen and if massive may lead to death in children. The contraindication of splenic aspiration are INR more than 2.5 and platelet count less than 40,000/cu mm. Bone marrow aspiration is easy to do and without any risk and is positive in 60-80% of cases. Lymph node aspiration and liver biopsy are positive in 60% and 50% of cases respectively.

The peripheral smear in kala-azar usually shows anemia, thrombocytopenia, neutropenia and lymphocytosis. Eosinophils are usually absent. The ratio of WBC to RBC may be altered from 1:750 to 1:2,000-1:10,000.

Serological Test

Aldehyde test (Napier test) is a very simple and non-specific test for kala-azar. The sensitivity of test is 35-94% with poor specificity. False-positive reactions may occur in children with cirrhosis, malaria, multiple myeloma. The increase in immunoglobulin is the basis of this test. In this test, one or two drops of formalin (40%) is added to 1-2 ml of patient's serum in a test tube. The egg white jellification of serum with opacification within 2-20 minutes indicates strongly positive reaction and within 24 hours, weakly positive.

Others serological tests with their sensitivity and specificity are outlined in Table 20.4.

Table 20.4: Serological tests (other than Aldehyde test) with their sensitivity and specificity in diagnosis of malaria

	Sensitivity	Specificity
1. Complement fixation test (1:8)	96%	
2. Counter immunoelectrophoresis	80-100%	—
3. Indirect fluorescent antibody test (1:28)	100%	98%
4. ELISA	98%	100%
5. DAT (Direct agglutination test) (1:1600)	100%	100%
6. FML	99%	100%

These serological tests are indirect evidence of kala-azar. DAT is very useful in diagnosis and epidemiological studies whereas ELISA to follow the disease during and after therapy.

Polymerase Chain Reaction

The discovery of minicircle sequence of kDNA is unique and species specific. PCR offers the best approach to parasite detection and characterization by amplifying sequence found in minicircle of leishmania using two primers;LSUC and LSUL. The test is 100% sensitive and specific and can detect a single parasite in biological sample.

Treatment

The specific treatment consists of administration of antileishmanial drug. In last decade a lot of new parenteral drugs have been tried and found to be effective but availability of oral antileishmanial drug has revolutionized therapy.

Pentavalent antimonials, Sodium stibogluconate (SSG), Meglumine antimonite and Urea stibamine are still the drug of choice for treatment of kala-azar despite a gradual increase in resistance against it. SSG is still the agent of choice. WHO has recommended that SSG should be used in a dose of 20 mg/kg/day (Max:850 mg) IM once daily for 30 days but duration may be extended up to 40 days in non responders. 60-80% of injected drug undergoes renal excretion within 6 hrs, therefore toxicities are very low. Children tolerate this drug better than adults. Toxic effects of SSG are hypersensitivity, arthralgia, myalgia, hepatitis, renal dysfunction, myocarditis and rarely pancreatitis (Table 20.5).

Table 20.5: WHO grading of parasite load in stained smear

Grades	Parasite density(/hpf)
6+	100 parasite/hpf
5+	10 parasite/hpf
4+	1-10 parasite/hpf
3+	1-10 parasite/10 hpf
2+	1-10 parasite/100 hpf
1+	1-10 parasite/1000 hpf
0	No parasite

Pentamidine isothionate is recommended in patients resistant to antimonials and cases associated with tuberculosis. The dose is 3-5 (4) mg /kg IV slowly daily or alternate day for a total of 10-15 doses. The drug should be given usually with 10% or 25% dextrose to avoid hypoglycemia. The efficacy of this drug is 77-81.5%. Toxic effects are hypo or hyperglycemia, hypotension, tachycardia, nephrotoxicity, GI disturbances, arrhythmias and sudden death. It should be given in a supervised settings because of danger of hypersensitivity reaction.

Amphotericin-B, an antifungal antibiotic which acts by binding to and inhibiting synthesis of sterol in the membrane of parasites creating multiple holes is very effective in resistant and relapse of kala-azar. The dose is 0.5-1 mg /kg IV with 5% dextrose over 6 hours daily or alternate day till a cumulative dose of 7.5-20 mg/kg. Toxic effects are anaphylaxis, thrombocytopenia, convulsions, chills, fever, thrombophlebitis, anemia, hypokalemia, nephrotoxicity, liver and cardiac damage. So all patients should be continuously monitored clinically and for electrolyte disturbances particularly hypokalemia. Recently liposomal Amphotericin-B has been found to be very effective in multidrug resistant kala-azar. The dose is 2 mg /kg IV alternate day or weekly for three doses (cumulative dose-6 mg/kg body weight). The drug achieves a higher concentration in reticuloendothelial system with more targeted response and no appreciable toxicities.

Aminosidine is an effective (95%) and well tolerated antileishmanial drug. The dose is 12-15 mg /kg/day IM for 21 days. Some authors recommend this drug as first line antileishmanial drug in endemic areas of kala-azar. It may be used in combination with SSG to achieve high cure rate.

Miltefosine, a phosphocholine analogue which was developed as antimalignant drug has shown to highly active against *Leishmania donovani* and achieved 97% cure in phase 3 trial in India. It is given orally in a

dose of 2.5 mg/kg/day OD or BD for 28 days. Side effects are transient and reversible and include GI disturbances, hepatic and renal dysfunction. It is cheap, safe, very effective and easy to administer. The availability of miltefosine would benefit even in rural areas and could serve as control measures. The drug should not be given in children below 2 years of age.

Interferon-gamma, 100 micro gm/m² sq body surface/day SC for 30 days, is an immuno-chemotherapeutic alternative for cases with repeated failure of conventional therapy. It improves the immune response as well as reduces the dose of antimonials.

Others antileishmanial drugs which can be used as adjunct are allopurinol (5-8 mg/kg PO for 1-3 wk), metronidazole, methylbenzylesters of leucine, inosine analogues, primaquine, cotrimoxazole and rifampicin.

Splenectomy needs to be reserved for cases with poor response to conventional antileishmanial drug and massive splenomegaly. It should be followed by SSG, 20 mg/kg/day IM for 20-40 days and penicillin prophylaxis. Prior to splenectomy, children must be vaccinated against *Meningococcus*, *Pneumococcus* and *H. influenzae*.

Monitoring of Therapy

Children on antileishmanial therapy should be monitored clinically (fever), hematological (Hb%, TLC, DLC), biochemically (CRP), Splenic size and parasitological index. Patients are categorized as cured if fever disappears, anemia and leucopenia improves and parasitological index is zero at the end and 6 months of therapy.

Prophylaxis

The sheetanchor of preventive attack is control of sandfly and early detection and treatment of kala-azar cases. *Kala-azar vaccine*, based on a combination of leishmania antigen and BCG vaccine, is round the corner.

Prognosis

About 13 to 20% cases of kala-azar are said to have spontaneous cure. The remaining generally respond well to treatment, provided it is started not-too-late. In some, the response may, however, be slow. Emergence of drug resistance (both primary and secondary), somewhat related to delay in diagnosis

and treatment, is a disturbing. Recurrences are well known.

FILARIASIS

Next to malaria, filariasis ranks supreme in the list of insect-borne diseases in tropical regions. In India, it is nearly a public health problem in the southern and eastern regions as also in parts of Uttar Pradesh. The disease is uncommon in north India.

Etiopathogenesis

The causative organism is *Wucheria bancrofti* in most parts of India. *Brugia malayi* is responsible for the disease in southern Asia including some parts of India.

The infection is transmitted by various species of mosquito, the *intermediate host*. The mosquito bites the man, the *definitive host*.

Through the punctured wound, the larvae enter the lymphatics. These larvae slowly mature and, at night, excrete microfilariae in the blood.

The infected host acts as the primary reservoir for spread of infection to others. This results from another bite of a female mosquito which sucks blood full of microfilaria. These microfilaria mature in the female mosquito into active larvae which migrate to the mouth of the mosquito, ready to be transmitted to a new host.

The male worm measures about 2.5 to 5 cm and the female 7.5 to 10 cm.

The major pathologic effect is the allergic tissue response (as the larvae are present in the lymphatics), like lymphagitis, adenitis, reticuloendothelial reaction, soft edema and varices.

Clinical Features

Recurrent filarial infections are necessary for significant clinical manifestations. The various phases are:

- Invasion*: This period is characterized by presence of transient urticaria, lymphadenitis, and eosinophilia.
- Inflammation*: Here, the patient may have acute illness with fever, lymphangitis, lymphadenitis, orchitis, epididymitis, lymphedema and delirium (*filarial septicemia*).
- Obstruction*: In this phase that usually follows repeated attacks, *elephantiasis* of the affected parts (usually lower limbs and genitalia with *W. bancrofti*

and arms and legs with *B. malayi*) is the most remarkable manifestation. *Chylous ascites*, *chyluria* or collection of milky fluid in other body cavities may also occur.

Diagnosis

Diagnosis is usually obvious in a full-blown case in an endemic area. In the differential diagnosis conditions such as congenital lymphedema (*Milroy disease*), venous thrombosis and generalized edema from other causes should be considered.

Confirmation of diagnosis is by demonstration of microfilaria in the blood film at night or in the body fluid.

Serology may be of some help in a proportion of the cases.

Treatment

Diethylcarbamazine, 50 mg on day 1, 50 mg twice and thrice on days 2 and 3, respectively, then 10 mg/kg on days 4 to 21). *Ivermectin*, 400 mcg/kg, in a single dose may reduce microfilaremia as effectively as diethylcarbamazine. Generally, one or more repeat courses are needed for consolidation of cure.

Symptomatic measures include analgesics and antipyretics, antiallergic agents, antibiotics to control superimposed bacterial infection, and elevation of the affected body part and its dressing with ichthyol-in-glycerine.

Treatment of filarial abscess is surgery. Plastic surgery may be done in certain instances.

Prognosis varies with the phase of the disease and the adequacy of the therapeutic measures.

Prevention

Filariasis is a public health problem in some areas. To control it, the following two steps must be taken on war-footing.

1. Mosquito control through antilarval measures, sewage disposal and use of mosquito nets.
2. Mass treatment with diethylcarbamazine in endemic belts.

TROPICAL EOSINOPHILIA

Also called *tropical pulmonary eosinophilia* and *Weingarten syndrome*, tropical eosinophilia is a disease of doubtful etiology confined to the tropical regions

such as India. Today, it is believed to be a kind of allergic response to filarial infection.

A gross eosinophilia, *eosinophil count exceeding 2,000/cmm*, is a "must" for this diagnostic label.

The most important pathologic lesions are nodules, 1 to 5 mm in diameter, scattered in the tissues such as lungs, liver and lymph nodes.

The disease spares children below 1 year of age. No other age is immune though incidence in the second year of life is the minimal.

Clinical Features

The chief manifestations are confined to the respiratory system. The onset is generally insidious. Persistent cough (often simulating asthma), some exertional dyspnea with wheezing, low fever, anorexia, growth failure and malaise are the presenting features in most cases. At times, vague abdominal manifestations may be present. Also, there may be enlargement of liver and lymph nodes. These manifestations tend to persist for months at a stretch without any significant systemic disturbances.

Diagnosis

Total leukocyte count is increased, sometimes to as high as 1,00,000/cmm. The total eosinophil count varies between 4,000 to 50,000/cmm, forming almost 30 to 80% of all the cells. ESR is usually high.

X-rays chest is abnormal in vast majority of the cases. Increased reticular markings, coarse mottling (especially at the bases) and hilar prominence are the usual radiologic lung findings (*eosinophilic lung*, *pulmonary eosinophilia*). Peripheral lung fields are usually clear.

High serum IgE levels, beyond 1,000 units/ml, and high titers of antimicrofilarial antibodies, or demonstration of blood-borne microfilariae strongly support the diagnosis.

Biopsy, though not usually needed, may demonstrate microfilariae in sections from lung or lymph node.

Tropical eosinophilia needs to be differentiated from bronchial asthma, some forms of pulmonary tuberculosis, bronchiectasis (while it is only mild) and chronic bronchitis. Gross eosinophilia associated with certain worm infestations, like *Loeffler syndrome* (caused by larval ascariasis), seldom persists beyond 3 weeks. *Visceral larva migrans* (caused by *Toxocara*

infection) generally spares the lungs. Remaining causes of eosinophilia include hay fever, drug reaction (penicillin, sulfas, aspirin, imipramine), sarcoidosis, mycosis, Hodgkin lymphoma and certain other tumors. In the so-called *hypereosinophilic syndrome* (very rare in children), cause of eosinophilia is not traceable and prognosis is usually grave.

Treatment

The drug of choice, diethylcarbazine, administered in a dose of 5 mg/kg/day, for 10 days, leads to prompt improvement. If the manifestations persist for 2 to 3 weeks or if they recur, a second course of the drug is warranted.

Prognosis

Children with tropical eosinophilia of short duration, as a rule, show dramatic response to therapy. However, those with chronic disease show less improvement.

TROPICAL SPLENOMEGALY

Tropical splenomegaly is the name applied to an etiologically obscure "chronic splenomegaly (moderate to gross) together with "undernutrition and anemia", encountered in children and young adults of tropics and subtropics (Fig. 20.2). According to current hypothesis, the entity is an abnormal immune response



Fig. 20.2: Tropical splenomegaly in an 8 year-old boy with chronic anemia and undernutrition

to malaria. There is evidence that, in a significant proportion of the cases, the fluorescent antibody titer against malaria is raised. *Big spleen disease*, *Bengal splenomegaly*, *cryptogenic splenomegaly* and *idiopathic splenomegaly syndrome* are some of the other nomenclatures by which it has been referred to in the literature.

Pathology

In one variety, liver biopsy shows varying degree of sinusoidal lymphocytosis.

In the second, liver histology is that of noncirrhotic portal fibrosis. Splenovenography reveals large dilated portal vein and the intrasplenic pressure is increased.

Recently, a third variety has also been described. In these children, liver biopsy shows a combination of the pathologic features of both the varieties.

Treatment

Since etiology is far from clear, management is nonspecific.

According to one school of thought, a prolonged course of antimalarial drugs (say chloroquine, one or two tablets every week for several months) is justified in all cases of tropical splenomegaly. Our experience in north Indian children indicates that such a regimen indeed leads to gratifying results in a significant proportion of cases. This observation also lends support to the current speculation regarding its etiology (vide above).

A shunt operation and/or splenectomy benefit the group of patients with advanced portal hypertension. Splenectomy may also be indicated in those with massive enlargement of spleen, causing severe and persistent abdominal pain and hypersplenism.

The foregoing comments summarize all that we know about this enigmatic entity. What is really wrong? Why does it happen? What can we do about it? These queries remain to be precisely answered through further research.

COMMON PARASITIC INFESTATIONS OF GUT

The high prevalence of intestinal infestations in the pediatric population of developing countries poses a serious challenge. Multiple infestations, the so-called *polyparasitism*, are often encountered. Varying degree of malnutrition is an important accompaniment of the clinical picture.

GIARDIASIS

Giardiasis, a cause of considerable morbidity and mortality in infancy and childhood, results, from infestation with the protozoal flagellate, *Giardia lamblia*. It is noteworthy that this protozoa was regarded as a commensal for a long time. In recent years, considerable evidence has accumulated establishing its pathogenicity. This is quite a fascinating example of how medical concepts undergo radical changes.

Giardiasis is especially more common in subjects with malnutrition or immunodeficiencies, say a gammaglobulinemia or selective IgA deficiency, as also in day-care centers and residential institutes for the mentally retarded.

Etiopathogenesis

Giardia lamblia infects through ingestion of cysts—person-to-person, water-borne, food-borne or interspecies transmission. On arrival in the upper small intestine, each cyst liberates 4 trophozoites which colonize the lumen of the duodenum and the proximal jejunum. Here, they attach to the brush border of the intestinal epithelial cells and multiply by binary fission. Its powerful sucking disc on its ventral surface causes insult to the microvilli of the intestinal mucosa, resulting in deficiency of the enzymes, *disaccharidases*, in the enterocytes. In addition, there may be pancreatic damage, causing extraintestinal steatorrhea and poor tryptic activity, deficiency of enterokinase secretion, fat malabsorption due to mechanical defect as well as overgrowth of bacteria in the duodenum and upper jejunum and deconjugation of bile salts, liberating free bile acids. IgA (secretory) in duodenal aspirate is low. T-cell function is depressed.

Clinical Features

Symptomatic patients have vague upper abdominal pain, recurrent diarrhea (stools are generally steatorrheic and often whitish), poor appetite (at times appetite may be voracious), failure to thrive and nutritional deficiencies. Occasionally, there may be acute dysentery-like presentation. Even transient ulcerative colitis has been described.

Diagnosis

Since *Giardia lamblia* cysts pass intermittently in stools, several stool samples (at least 3, preferably 6) on



Fig. 20.3: Vegetative (trophozoite) form of *Giardia lamblia*

successive or alternate days are needed for meticulous microscopy. Yet, 25 to 50% infected subjects may be missed (Fig. 20.3).

A duodenal aspirate (or peroral biopsy) is a better method of detecting *Giardia lamblia*. It is called *Enterotest*.

Endoscopic brush cytology is a yet superior diagnostic tool.

An enzyme-linked immunosorbent assay (ELISA) promises to be an inexpensive, efficient and simple method for detecting *Giardia lamblia* in stool sample rapidly.

Chemotherapy

Mepacrine, 5 to 8 mg/kg/day (divided doses) for 5 to 7 days gives excellent clinical as well as parasitologic cure of the magnitude of nearly 100%. Unfortunately, it has very bitter taste, is poorly tolerated and is toxic. Transient yellow staining of the skin may occur in some patients. Moreover, it is not easily available now. These considerations limit its routine use in the eradication of this infestation. The following new drugs have fast replaced it.

Metronidazole comes fairly close to mepacrine in efficacy. Today, it occupies pride of the place as an anti-giardia agent. It is quite safe. But, since it is excreted in the saliva, a bad taste in the mouth is often irritating to the patient. The dose is 10 to 20 mg/kg/day for 5 to 7 days. The drug is best given in divided doses. Remember, subjects on phenobarbital therapy should receive 2 to 3 times higher dose of metronidazole to be effective.

Tinidazole is remarkably effective as an anti-giardial agent. Given in a dose of 50 mg/kg once only, it yields a high clinical and parasitologic cure rate. Tinidazole may also be administered in a dose of 20 mg/kg/day for 5 days. It is fairly safe.

Secnidazole, in a dose of 30 mg/kg, once only, too yields a high cure rate. It is quite safe.

Furazolidine is another potent anti-giardial drug. It is administered in a dose of 8 mg/kg/day (divided doses) over a period of 10 days. It may cause some gastrointestinal upset and headache. It invariably stains the urine. Occasionally, mild drug rash may occur.

Albendazole, 400 mg (200 mg for < 2 years) daily for 5 days also gives gratifying results.

Ornidazole, a relatively new imidazole, 40 mg/kg as a single dose once only, is not only very effective but is better tolerated by children compared to the earlier imidazoles.

Nitazoxanide, 7-10 mg/kg/dose twice daily for 3 days, gives excellent results. Side-effects include abdominal pain, diarrhea, vomiting and headache. It is also effective against *Cryptosporidium parvum*, *E. histolytica* and helminthes. Fascioliasis needs treatment for 7 days.

The Problem of Resistant/Repeated Giardiasis

Not infrequently, children with resistant symptomatic giardiasis need repeated courses of an anti-giardial agent as such or in different combinations. The probability of hypogammaglobinemia must be considered in children who fail to respond to repeated courses of such a therapy. The so-called "resistance" needs to be differentiated from a common situation in which repeated infection occurs as a result of continuing exposure to poor food and water hygiene and environmental sanitation which indeed affects most members of the family or the institution.

AMEBIASIS

Infection with the protozoa, *Entamoeba histolytica*, is relatively less common in infancy and childhood. The incidence is far less than the average of 20% seen in our adult population.

Etiopathogenesis

Infection is transmitted by contaminated water and food either through food handlers or direct contact with infected stools.

On arrival in the small intestine, the trophozoites of *E. histolytica* float in the intestinal contents. On reaching the large intestine, they invade the intestinal mucosa, causing tissue destruction in the form of ulcers with slight inflammatory response. The cecum, transverse colon and the rectosigmoid region are most vulnerable to insult because of slow movement of the colonic contents.

E. histolytica may reach the liver through blood stream and produce similar lytic lesions, the so-called *amebic liver abscess*. The abscess is usually sterile, containing viscid, chocolate-colored non-pyogenic material. It may be single or multiple. Amebic empyema and pulmonary amebiasis may result following transdiaphragmatic rupture of liver abscess.

Occasionally, *E. histolytica* may disseminate to lungs or brain through hematogenous spread.

Rarely, amebae may enter the brain through olfactory neuroendothelium in swimmers. These free living amebae (*Naegleria* or *Hartmanells Acanthamoeba* group) cause a new form of meningoencephalitis.

Clinical Features

The symptom range from mild gastrointestinal upset to acute dysentery/diarrhea or chronic colitis. Unlike adults who may have only loose motions, children usually pass mucus (free of pus) together with blood. The latter is generally not mixed with the fecal matter or the mucus. Abdominal pain and tenesmus may also accompany.

The complications include amebic liver abscess, hepatitis, partial or complete intestinal obstruction, intussusception, perforation of the colon, peritonitis and rectal ulcers and fistula. Rarely, empyema may occur.

A group of patients may remain symptom-free though they pass cysts in their stools. The incidence of symptom-free cyst-passers in pediatric practice is very low.

Diagnosis

Diagnosis is based on demonstration of *E. histolytica* cysts or trophozoites in stool samples. At least 3 and preferably 6 samples need to be meticulously examined microscopically on successive days to rule out amebic infection of the gut. Alternatively, smear of the ulcerated area of the rectal mucosa may be examined microscopically for the organisms.

In case of liver abscess, aspirate should be examined for *E. histolytica*.

In highly suspected subjects in whom stool samples continue to be negative, endoscopy and biopsies should be performed.

Indirect hemagglutination test may assist in diagnosing invasive intestinal infection and amebic liver abscess. A titer of at least 1:128 is diagnostic.

Chemotherapy

Metronidazole, 20 to 50 mg/kg/day, for 10 to 14 days, gives excellent results. A high daily dose rather than the prolonged duration of therapy is important. Along with metronidazole, tetracyclines may be given for few days for still better results. Many prefer to give a suitable luminal amebicide—diodohydroxyquin or, still better, diloxanide furoate which is safer and yet more effective than the former. This should be given following metronidazole therapy. Alternatively, especially if the illness is severe or if metronidazole cannot be employed for some reason, dihydroemetine, 1 mg/kg/day (IM or SC) for 10 days, is recommended. In view of possibility of cardiac or renal complications, dihydroemetine must be administered in the hospitalized patient only. Therapy with this drug must be followed by a course of diloxanide furoate.

Metronidazole is effective in hepatic involvement as well. Excellent result has been obtained in amebic liver abscess with intravenous metronidazole, 21 mg/kg/day in 3 divided doses as infusion, followed by oral medication for 10 days. Dehydroemetine is also very effective. Some prefer to use chloroquine hydrochloride, along or in combination with another antiamebic drug.

Liver abscess may require needle aspiration in addition to drug therapy in these situations:

- Failure of manifestations to respond to adequate drug therapy,
- Massive abscess, causing markedly elevated diaphragm,
- Palpable abscess with impending rupture, and
- Persistent pain and tenderness locally with referred shoulder pain.

Recently, excellent results have been obtained with *tinidazole* in a dose of 60 mg/kg/day for 3 days.

Secnidazole, in a dose of 30 mg/kg, given just once, too gives gratifying results.

Ornidazole, 20-25 mg/kg/day for 5-10 days claims to yield excellent cure rate.

ACANTHAMOEBA

Acanthamoeba, *Naegleria*, and *Balamuthia* constitute the free-living amoebas, which are distinct from other pathogenic protozoa by the nature of their free living existence, the lack of an insect vector or human carrier state, and the limited relationship of poor sanitation with the spread of infection. *Acanthamoeba* causes 2 distinct clinical syndromes constituting keratitis in contact lens wearers and granulomatous amebic encephalitis (GAE). This amoeba, on occasion, may be cultured from the pharynges of healthy persons.

Epidemiology

Acanthamoeba has been isolated from soil, water, and air. Keratitis occurs in healthy people, usually those who wear contact lenses. Keratitis has been associated with wearing nondisposable contact lenses, the use of sodium chloride solution to clean the lenses, and wearing lenses while swimming. The isolation of *Acanthamoeba* from swimming pool water is not unusual. No correlation exists between the presence of *Acanthamoeba* in swimming pool water and the bacteriologic quality of the water. *Acanthamoeba* cysts are very resistant to chlorine. A higher percentage of isolates from swimming pools are pathogenic than those isolated from natural fresh water. GAE usually occurs in patients with underlying disease, such as AIDS, liver disease, organ transplantation, and diabetes mellitus. Disseminated infection in people with AIDS occurs with a CD4+ lymphocyte count of less than 200 cells/mL. A correlation may exist with recent swimming in warm freshwater. Keratitis does not lead to systemic infection or death, but it may be complicated by cataracts, hypopyon, and increased intraocular pressure. GAE has a very high mortality rate.

Pathophysiology

Acanthamoeba keratitis occurs in patients with minor corneal trauma usually due to wearing contact lenses. The amoebae are introduced via contaminated solutions such as sodium chloride solution. The subsequent inflammatory reaction results in some neovascularization. *Acanthamoeba* reaches the central nervous system in patients with GAE via the blood stream. The primary sources for dissemination include the sinuses, lungs, or skin.

Clinical Features

Children bearing contact lenses with history of swimming in pool usually present with complain of foreign body sensation in eyes, severe pain, photophobia, watering from eyes, and redness. On examination there are evidences of conjunctivitis and keratitis. Neurological manifestations include change in behaviour, seizures, signs of meningeal irritations, cranial nerve palsies, hemiparesis, visual disturbances, ataxia and headache. Skin lesions, including ulcers, nodules, or subcutaneous abscesses may occur.

Diagnosis

The diagnosis is usually done by demonstration of cyst in corneal scrapings after staining with calcofluor white and examination under fluorescent microscopy. PCR is useful to identify organisms. Children with neurological manifestations, Cerebrospinal fluid examination reveals an increased number of white blood cells (as many as 800 cells/cu mm, primarily lymphocytes), elevated protein, and decreased glucose. CT scan of brain shows multiple non-enhancing lesions in cortex and ventriculomegaly.

Treatment

Medical therapy for acanthamoeba infection is not well established. Treatment for keratitis is topical. Two types of preparations are recommended: diamides (propamide isethionate and hexamide) and cationic antiseptics (polyhexamethyl biguanide and chlorhexidine) but not available in our country. Many authorities recommend using a diamide and a cationic antiseptic immediately after corneal debridement every hour for 48 hours. These agents then are continued hourly during waking hours for another 3 days. The frequency then is reduced to every 3 hours. Two weeks may be required before a response is observed, and the total duration of therapy frequently is 3-4 weeks.

Recently it has found that there are no difference in response to medical therapy for those who used topical steroids compared with those who did not. However, patients treated with topical steroids required longer duration of medical therapy. Penetrating keratoplasty may be necessary in patients who do not respond to medical therapy.

Ketoconazole, sulfamethazine or pentamidine and flucytosine should be used for granulomatous amebic

encephalitis. Chlorhexidine gluconate and ketoconazole cream are very effective in skin lesions.

CRYPTOSPORIDIOSIS

The intestinal protozoan, *Cryptosporidium*, is now recognized as an important cause of self-limited watery diarrhea in immunocompromised patients such as having AIDS or congenital immunodeficiencies.

Etiopathogenesis

Infection is transmitted by fecooral route, person to person, through water and food. After the oocytes are established in the gut, excystation occurs. Further development occurs at the surface of the intestinal epithelium. Jejunum is the usual seat of *Cryptosporidium*. In immunocompromised individuals, it may invade the colon and the biliary tract. In such patients, it may cause cholecystitis, pancreatitis and papillary stenosis. Even in children who are immunocompetent, cryptosporidiosis should be considered as an important factor in development of malnutrition.

Clinical Features

Incubation period is 2 to 7 days.

Manifestations in immunocompetent children include acute watery diarrhea, vomiting, and abdominal cramps. Infection subsides in 10 to 14 days on its own.

In immunocompromised children, manifestations include severe watery diarrhea which tends to become persistent, resulting in weight loss and malnutrition.

Diagnosis

Laboratory detection of the cases is difficult. Identification of the oocytes is by special acidfast staining method on stool sample or mucosal biopsy specimen.

Treatment

Immunocompetent children with diarrhea from cryptosporidiosis need no specific therapy except for fluids and electrolytes and adequate nutrition. In immunodeficient children, protracted diarrhea is not responsive to any drug therapy. In reversible immunodeficiency, elimination of immuno-suppression leads to recovery.

ASCARIASIS

The great roundworm, *Ascaris lumbricoides*, perhaps accounts for the highest proportion of intestinal parasitosis. It is about 20 to 40 cm in length. Its appearance is so characteristic that the diagnosis is practically beyond doubt when there is history of passage of snake-like worms in the stools or in the vomitus. Often, these worms scare the young child.

Etiopathogenesis

3 The larva-containing egg (oval, 40 × 60 μm) passed in the stools of infected individuals is the infective stage of *A. lumbricoides*. This egg matures in 5 to 10 days to become infective under favorable conditions. When this mature egg is swallowed by the human host, it hatches out in the duodenum to release larvae which penetrate the intestinal wall, enter the venous circulation and migrate to the lungs. From the alveolar spaces, larvae ascend the bronchial tree and the trachea, cross over the epiglottis, and are reswallowed to reach the small intestine where they mature into adult worms.

Each female roundworm is capable of producing 200,000 eggs a day, and surviving for 1 to 2 years.

Clinical Features

The clinical picture depends on the wormload, child's nutritional status and worm location in or outside the GIT.

Pain abdomen, abdominal distention, growth failure, anemia, vitamin deficiencies and voracious appetite are the usual presenting features. Pica, sleeplessness, irritability, urticaria, eosinophilia and diarrhea are associated in some cases. Occasionally, intestinal obstruction may be encountered. Small intestinal function and structure, however, remain normal.

Migration of larvae may cause *ascaris pneumonia* (*Loeffler syndrome*), asthma-like manifestations, hepatomegaly, splenomegaly or encephalopathy. Gross eosinophilia and leukocytosis are generally present. A picture resembling retinoblastoma may result from involvement of the eye.

Chemotherapy

Piperazine is ideal for eradication of roundworm infestation. A dose of 100 to 150 mg/kg with a

maximum of 3 to 4 g as a single administration, for one to two days, gives excellent results. No special preparation or purging is needed. With this dose piperazine does not produce any significant side-effects. Larger doses may cause vomiting, blurring of vision, muscle weakness, urticaria and, very rarely, convulsions. It is best avoided in patients suffering from or with predisposition to epilepsy. It is highly effective against oxyuriasis as well.

The new anthelmintics which have proved quite effective against roundworm are:

Thiabendazole, a broad-spectrum anthelmintic, (also effective in oxyuriasis, ancylostomiasis, strongyloidiasis and trichuriasis) is best administered in a dose of 50 mg/kg/day, with a maximum of 2 g/day, in two divided doses to be given after principal meals, on two successive days. No preparation or purging is required. It is a fairly safe drug but some degree of drowsiness and mild gastrointestinal upset are often encountered. Occasionally, drug rash (even Stevens-Johnson syndrome), headache, numbness, abnormal ear and ocular sensations, hyperglycemia and hepatic dysfunction may occur.

Tetramisole and levamisole, also effective against hook-worm, are administered in a dose of 2.5 to 5.0 mg/kg with a maximum of 150 mg as a single administration (once only). No special preparation is required. Mild gastrointestinal upset may occur.

Pyrantel, 10 mg/kg as a single administration (once only), gives excellent results. It is well tolerated. GIT upset, headache and dizziness occur occasionally. Drowsiness, insomnia and rash occur infrequently. Rarely, it may cause mild hepatic dysfunction. It is effective in ancylostomiasis, oxyuriasis, ascariasis, strongyloidiasis and trichuriasis, as well. Remember never to administer it along with piperazine as the latter may antagonize its action.

Mebendazole, a broad-spectrum anthelmintic (also effective in oxyuriasis, ancylostomiasis, strongyloidiasis, trichuriasis, and teniasis), given in a dose of 100 mg twice daily for 3 days, gives almost 100% cure rate. No purgation is required. Its action is wormicidal. No significant side-effects have been reported.

Albendazole, a broad-spectrum benzimidazole anthelmintic, gives excellent results in ascariasis as also enterobiasis, ancylostomiasis and trichuriasis when given in a single dose of 200 mg in children under 2 years and 400 mg in those beyond 2 years. The same dose, when administered on 3-5 successive days,

renders the drug effective against *Strongyloides stercoralis* and tape-worms, including *H. nana*.

OXYURIASIS

Infestation with *Enterobius vermicularis*, popularly known as threadworm or pinworm, is very common, particularly in infants and young children. Often, there is a history of passage of worms which is invariably reliable. Routine stool examination will usually miss the ova. Cellophanetape technique should be employed in doubtful cases.

Etiopathogenesis

Embryonated eggs carried under fingernails following perianal scratching, on clothing, bedding or house dust infect human host (the only natural host of *E. vermicularis*) after being ingested. Eggs hatch in the small intestine. The larvae migrate into cecal region where they mature into adult worms. The gravid female wanders by night to the perianal region to lay eggs, causing intense pruritus. Each egg measures 30 to 60 μm , and matures after 6 hours into a single coiled larva which has a viability of 20 days.

Clinical Features

Pruritus ani, with or without superadded infection due to intense scratching, is the commonest manifestation. In some girls, there may be associated vulvovaginitis. Irritability, restlessness, sleep disturbances, behavior problems like grinding of teeth, masturbation, and enuresis, abdominal pain, diarrhea, and poor appetite are present in a proportion of the cases. Rarely, threadworms may cause serious complications like appendicitis and salpingitis.

Chemotherapy

Pyriwinium, 5 mg/kg, as a single dose, is a very potent agent against threadworm infestation. It gives almost 100% results. It is a cyanine dye. Understandably, it invariably stains the stools. Some nausea, vomiting and, occasionally, muscle cramps may occur.

Piperazine, 70 mg/kg/day with a maximum of 2.5 g for 7 days, is also very effective. The prolonged course of treatment, that sometimes becomes almost impracticable, weighs against its being the drug of choice.

Albendazole, thiabendazole and pyrantel are also quite effective.

Mebendazole, in a dose of just 100 mg once only, gives excellent results.

ANCYLOSTOMIASIS

Hookworm infestation is particularly common among the rural population and the slum-dwellers of the towns.

Etiopathogenesis

Hookworm larvae, living in favorable environmental conditions (warm, damp soil), become infective in 1 to 2 weeks by molting twice and penetrate the human host's skin (usually bare foot). The larvae migrate to the venous circulation to reach the lungs. From the alveolar spaces, they limb upward and cross over the epiglottis when they are swallowed to reach the upper small intestine, their final habitat. In 2 to 4 weeks, they mature into adult worms, 5 to 13 mm in length. In next 6 to 9 weeks, they attain sexual maturity and start depositing eggs (*A. dodenale* 30,000/day, *A. americanus* 9,000/day) which are excreted in stools. Each egg measures 36 × 58 μm and is characterized by four embryonic segments. Larvae survive in the soil for 1 to 2 weeks before they turn infective.

Hookworm infection may also be acquired by oral route.

Morbidity of hookworm infection depends mainly on the worm load and the diet of the host. Lesions may occur during the migratory phase (ground itch, mild pulmonary lesions) or presence of the adult worms in the small intestine (anemia as a result of 0.03 to 0.3 ml/worm/day blood sucking, hypoproteinemia).

Clinical Features

The prominent clinical features are progressive anemia, anorexia, pain abdomen and malnutrition. Pica is often present. Advanced cases may have gross anemia with hypoproteinemia, leading to edema and even anasarca. Diarrhea, alternating with constipation, may also be present. Some degree of malabsorption, as a result of histologic as well as functional damage to the small intestinal epithelium, occurs in many cases.

To so-called *ground itch*, as a result of larval skin invasion over feet (buttock in infants), is often mild and unnoticed. Occasionally, it may be seen as an irritant, papulovesicular rash or even as *cutaneous larva migrans*.

Infantile hookworm disease is the term applied to a distinct clinical entity characterized by nausea,

vomiting, restlessness, diarrhea with bloody stools, malena and anemia. Besides skin as the portal of entry, it can develop following transmammary transmission or, rarely even transplacental transmission, if the mother is suffering from ancylostomiasis. Majority of its documentations are from China.

Chemotherapy

If hemoglobin is under 5 g/dl correction of anemia with iron or blood transfusion must precede rather than follow the anthelmintic therapy.

3

Tetrachlorethylene is the drug of choice, especially in infestation with *Necator americanus*. The dose is 0.1 ml/kg with a maximum of 3 to 4 ml to be administered after overnight fasting. No purgation is needed. Nausea, vomiting, dizziness and drowsiness may occur in some patients. It is quite cheap and thus of value in mass-scale deworming, especially of rural population.

Bephenium hydroxynaphthoate is another very effective and extensively-used agent. The dose is 2.5 g for children under 5 years and 5 g for those above 5 years. No preparation and purgation are required and a solitary administration suffices in a great majority of the cases. Side-effects include nausea, vomiting, diarrhea and a slight fall in blood pressure. This drug is somewhat effective in ascariasis as well.

Albendazole, *thiabendazole*, *tetramisole* and *levamisole*, are other drugs being currently used in treatment of ancylostomiasis.

Pyrantel is also of value. For heavy infestation with *Necator americanus*, a dose of 20 mg/kg/day for 2 successive days is given.

Mebendazole, in same dose as for ascariasis, also gives very high cure rate.

STRONGYLOIDIASIS

Strongyloides stercoralis infection is not a common problem in our country. It resembles hookworm in many ways.

Etiopathogenesis

Larvae of *S. stercoralis*, passed by the infected individuals in stools, develop into free-living adults or infective filiform larvae in the soil. The infective larvae penetrate the host's skin and enter the lungs via venous circulation. Like hookworm and roundworm larvae,

they work out their way to their final habitat, i.e. small intestine (upper). The mature worms burrow into the epithelium, and release eggs, which hatch rapidly, releasing small larvae that pass in stools. The larvae in the soil (sometimes in the intestine or at the anal region) undergo morphologic changes to be ready to infect human host.

Morbidity produced by *S. stercoralis* depends on such factors as worm load, host's nutrition and immune status. Manifestations are related to the entry and course of the parasite in the body. Infrequently, it may cause larval invasion of internal organs (*disseminated strongyloidiasis*) which is invariably complicated by gram-negative septicemia.

Clinical Features

Mild itching and urticaria, at the site of penetration into the skin, pain abdomen, severe diarrhea, malabsorption, malnutrition, and chest manifestations simulating *Loeffler syndrome* are the chief presenting features.

Chemotherapy

Dithiazinine used to be the drug of choice. Since it may get absorbed and cause serious toxicity, it has now been replaced by *albendazole*, *thiabendazole*, *pyrvinium* and *mebendazole*. In our experience, a very high cure rate can be accomplished with pyrvinium, if we administer it in a dose of 5 mg/kg/day for 7 successive days rather than as a single dose.

Mebendazole is of value in a dose of 200 mg twice daily for 3 days. Ivermectin, 200 mg/kg/day, for 1 to 2 days is effective in children over 5 years of age.

TRICHURIASIS

Infection with *Trichuris trichiura*, the so-called *whipworm*, is rather uncommon in most parts of our country though a very high incidence has been reported from certain other tropical and subtropical regions.

Etiopathogenesis

Embryonated eggs of *T. trichiura* from the soil are transmitted by contaminated hands, food or water, flies and other insects to the human host by feco-oral route. In the small intestine, the eggs hatch and the larvae penetrate into the villi. After 3 to 10 days, they

move down to their final habitat, i.e. cecum and ascending colon. It takes 1 to 3 months before maturing female worms start depositing eggs. Each adult worm sucks 0.005 ml of blood/day.

Clinical Features

Prolonged diarrhea with blood-streaked stools, right lower abdominal pain, tenesmus, malnutrition with anemia, rectal prolapse and allergic manifestations like eosinophilia and *Charcot-Leyden crystals* in stools are the prominent clinical features. Children of preschool age are the ones who predominantly suffer from this infestation. The worms may be seen on the surface of the prolapsed rectal mucosa.

It has been observed that children with whip-worm are especially prone to have additional roundworm and amebic infestations.

Chemotherapy

Eradication of whipworm is a difficult problem. Dithiazinone, though effective, is no more employed because of its serious toxicity.

Thiabendazole is effective but the cure rate is not that encouraging.

Of late, albendazole, mebendazole and pyrantel seem to hold promise as the drugs of choice for this infestation. The dosage regimen remains the same as for ascariasis and ancylostomiasis.

Another treatment for obtaining clinical cure appears to be in the form of high enemas of 0.2% hexylresorcinol retained for 20 to 30 minutes. Care must be taken so that spilled solution does not cause burns over perianal and surrounding skin. Coating the buttocks and thighs with petroleum jelly is of value.

TAPEWORMS

Hymenolepis nana infestation is quite common in India. It needs no intermediate host. *Tenia solium* infection occurs by consumption of meat of an infected pig (pork) and *Tenia saginata* that of cattle (beef). Box 20.1 gives important differences between *T. solium* and *T. saginata*.

Clinical Features

Tenia solium (pork tapeworm): Most often, parents bring the children for passing 1 to 2 cm long segments (proglottides) in stools or crawling over the perianal area.

Box 20.1: *T. solium* vs *T. saginata*

<i>T. solium</i>	<i>T. saginata</i>
<ul style="list-style-type: none"> • Pork tapeworm • About 3 meter long • About 1,000 segments • Cysticercosis is a frequent complication 	<ul style="list-style-type: none"> • Beef tapeworm • About 6 meter long • About 2,000 segments • Cysticercosis is an uncommon complication

Growth failure despite voracious appetite, abdominal distention and pain and recurrent diarrhea may be the presenting manifestations in some. *Cysticercosis* can lodge anywhere in the body. Involvement of the brain (which may show as calcification* in the skull X-ray) may cause convulsion, at times, simulating a brain tumor, hydrocephalus or meningitis. Calcified nodules may be palpable in the muscles.

Tenia saginata (Beef tapeworm): Clinical manifestations are like those of *T. solium*. It is less likely to cause cysticercosis. Absorption of a neurotoxin may, however, cause paresthesia and squint. Calcification may be detected in skull X-ray.

Hymenolepis nana (Dwarf tapeworm) Contrary to earlier teaching, *H. nana* is now known to cause considerable morbidity in children. A follow-up of the symptomatic carriers reveals that they do become symptomatic sooner or later. Abdominal pain, loss of appetite, chronic diarrhea and malnutrition are common manifestations.

Chemotherapy

Mepacrine, 15 mg/kg (with a minimum of 40-50 mg for a child of 4 years), given as a single dose or in divided doses at 5 to 10 minute intervals, is the time-honored treatment. It is advisable that a saline purgative is given 1 to 2 hours after completion of the total drug administration. This helps in expelling the worms. Also, the patient should have had overnight fast and given a suitable antiemetic half to one hour before drug administration. *Mepacrine* is, unfortunately, very bitter and has poor acceptability. In pediatric practice, very often it becomes necessary to administer it through a Ryle tube.

Niclosamide is a major breakthrough in the chemotherapy of tapeworms. It is highly effective in

* Other cause of calcification include tuberculoma, craniopharyngioma, astrocytoma, dermoid, hypervitaminosis D. hyper- and hypoparathyroidism, phakomatosis and intrauterine infection

T. saginata (relatively less so in *T. solium**) and *H. nana*. The recommended dose varies with weight. For weight 11 to 34 kg, initial dose is 1 g followed by 500 mg daily for 6 days. For over 34 kg weight, initial dose is 1.5 g followed by 1 g daily for 6 days. In terms of body weight dose is 40 mg/kg/day.

Praziquantel, 10 mg/kg for *T. saginata* and *T. solium* and 25 mg/kg for *H. nana* once only yields gratifying results.

Dichlorophen, yields encouraging results in the treatment of tapeworms. Dose is 2 to 4 g (4 to 8 tablets)/day on two consecutive days.

Mebendazole, 200 mg twice daily for 3 days, is effective in *T. saginata* and *T. solium*.

For neurocysticercosis, praziquantel (PZQ), 50 mg/kg/day in 3 divided dose for 2 weeks, is currently the drug of choice.

Alternatively, albendazole, 15 mg/kg/day in 3 divided doses for 28 days may be given. Recent experience shows that it is equally effective when given for only 5 days and may turn out to be superior to PZQ.

NEUROCYSTICERCOSIS (NCC)

Cysticercosis is the most common parasitic disease of the central nervous system. It is caused by the larval stage of the tapeworm *Taenia solium*. The disease has worldwide distribution.

There are two main routes from which humans acquire cysticercosis: ingestion of food contaminated with human faeces containing *T. solium* eggs and anus to mouth self contamination in patients harbouring the adult worm in their digestive tract.

Cysticercus is a fluid filled sac which varies in size from 0.5 to 5cm or more in diameter. Scolex is a structure which resembles adult *T. solium* and found in invaginated form inside the cysticercus sac. The cysticerci may lodge in brain parenchyma, spinal cord, eyes, ventricular system, subarachnoid space and muscle.

Brain parenchymal cysticerci are usually small cysts, single or multiple, that tend to lodge in areas of high vascular supply.

Clinical Features

Cysticercosis affects men and women equally from birth to senility. The peak incidence is between the

third and fourth decades of life. The clinical manifestations depend upon number and topography of lesions, the individual immune response to the parasite, and the sequelae of previous infestations.

The common manifestations are partial seizures with secondary generalization or other types of seizures, pyramidal tract signs, sensory deficit, involuntary movements, cerebellar ataxia and unsteady gait, signs of brainstem dysfunction intellectual deterioration, dementia and psychosis and cysticercotic encephalitis/meningitis. Children with cysticercus encephalitis present with signs mental disturbances, diminution of visual acuity and generalized seizure.

CT Head is still most useful diagnostic tool for the diagnosis of NCC. CT provides reliable information about the topography of the lesions and disease activity. There are four CT patterns of parenchymal NCC: Small calcifications or granulomas, rounded areas of low density showing little or no enhancement after intravenous contrast (vesicular cysts), scattered hypodense or isodense lesions surrounded by edema and ring like enhancement after contrast (colloidal cysts).

MRI provides useful information in the evaluation of NCC patients, especially when CT findings are not conclusive. Both CT and MRI are mutually complementary in providing optimal non-invasive diagnosis.

Treatment

Medical Therapy

- A. Cysticidal Drugs
 - a. Albendazole: 15 mg/kg/day for 1 week
 - b. Praziquantel: 50 mg/kg/day for 2 week
- B. Antiedema Measures

Prednisolone: 1-2 mg/kg body weight
- C. Antiepileptic Therapy

Phenytoin sodium or carbamazepine for 2-3 months
- D. Surgical Therapy:

It is indicated for intraventricular and subarachnoid NCC.

General principles of treatment are: Parenchymal granulomas or calcifications do not require treatment with cysticidal drugs because these lesions represent only the sequelae of previous cysts which were destroyed by the host's immune system.

* Moreover, use of niclosamide in *T. solium* carries a theoretical risk of cysticercosis

Symptomatic treatment with antiepileptics is advised when calcifications are associated with seizure.

Prevention

The main measures for prevention of cysticercosis are proper disposal of human waste, treatment of water contaminated with human feces before its use in irrigation of vegetable cultivation, proper cooking of pork, public education on life cycle of *T. solium*.

HYDATID DISEASE (*Echinococcosis*)

Clinically-recognizable hydatid disease occurs when hydatid cysts, following infection with the larval stage of the canine tapeworm, *Echinococcus granulosus*, present as space-occupying lesions in the liver, or, infrequently, in lungs, brain, bones and spleen.

Human infection with *E. granulosus* is acquired by ingestion of parasite eggs present in the feces of dogs or wolves who acquire infection by eating parasitized viscera of sheep or cattle. It takes several years for hydatid cysts to grow.

The disease is most common in regions where sheep and cattle are raised.

Manifestations appear only in a small proportion and are the result of space-occupying nature of the cysts.

In the commonest variety, *hydatid disease of the liver*, a large cystic hepatomegaly with pressure symptoms is the usual presentation.

Pulmonary hydatid disease is relatively more frequent in children. Manifestations include cough, hemoptysis and dyspnea.

Hydatid disease of the bones manifests as erosions and spontaneous fractures.

Hydatid disease of the spleen manifests as massive splenomegaly.

Diagnosis is confirmed by roentgenographic and ultra-sonic examination, by Casoni test, and by serologic tests.

The drug of choice is albendazole, 15 mg/kg/ day in 3 divided doses for 28 days. Four or 5 such courses at 15 day drug-free interval may be needed.

Medical therapy may be supplemented with surgery.

FURTHER READING

Articles/Chapters

1. Dani VS. Malaria. In: Gupte S (Ed) *Recent Advances in Pediatrics*, Vol 14. New Delhi: Jaypee 2004:19.
2. Gupte S. Congenital malaria in north India. In Mir NA, Hassan M (Eds) *Current Trends in Perinatal Medicine (Proceedings, Intern. Symp on Emergencies in the Neonate and VII Ann Conv Nat Neon Forum)*, Srinagar 1987:127.
3. Gupte S. Chemotherapy of intestinal parasitosis. In: Gupte S (Ed) *Recent Advances in Pediatrics (Special Vol. 6 Gastroenterology, Hepatology and Nutrition)*. New Delhi: Jaypee 2000:240.
4. Singh K, Singh R, Parija SC, Faridi MMA: Infantile hookworm disease. *Indian J Pediatr* 2000;67:241.
5. Singh UK: Diagnosis and management of kala-azar. *Indian Pediatr* 1999;36:231.
6. Singhi P, Dayal D, Khandelwal W. One week versus four weeks of albendazole therapy for neurocysticercosis in children: A randomized, placebo-controlled double-blind trial. *Pediatr Infect Dis J* 2003;22:268.

Book/Monograph

1. Malaria Vaccine Technology Roadmap. <http://www.malariavaccine-roadmap.net/pdfs/malariavaccine-TRM-Final-PDF>. Last accessed 6 June 2008.

PART FOUR

Pediatric Subspecialties



CHAPTER



Pediatric Pulmonology

Daljit Singh, Suraj Gupte

INTRODUCTION

Diseases pertaining to the respiratory system are responsible for a large proportion of pediatric admissions and outpatient attendance. In north India, the highest incidence is recorded in the winter followed by the relatively lower peak during rainy season.

Like in other tropical areas. Indian infants and children demonstrate pattern of clinical presentation which is somewhat different from what is recorded by the western authorities. This variance is related to factors such as considerable delay in reporting to the hospital and high frequency of infestations and associated malnutrition. All these, individually or collectively, result in a rather changed clinical picture.

CLINICAL EVALUATION OF A RESPIRATORY CASE

For role of history-taking and clinical examination in evaluation of a respiratory case, see Chapter 1.

SPECIAL DIAGNOSTIC PROCEDURES

Radiology/Imaging

Chest X-ray, PA and lateral views as a routine, decubitus film for pleural effusion, oblique film for focus on hilar shadow, and lung portion at the back of heart, lordotic film for apices, lateral neck film for upper airway obstruction round the level of retropharynx, subglottis and supraglottis.

Barium swallow is useful in excluding tracheoesophageal fistula (TEF) of H-type, gastroesophageal reflux disease (GERD) and esophageal indentation with vascular rings.

Screening is of value for stridor and movements of diaphragm and mediastinum.

Ultrasonography is useful in pleural effusion and intrathoracic masses as also in guiding conduction of lung tap and pleural tap.

CT scan is very helpful in pleural, mediastinal, and parenchymal (both solid and cystic) lesions, bronchiectasis, vascular structures (provided that IV contrast enhancer is employed), and guiding biopsy.

MRI is particularly of great value in vascular rings and hilar structures.

Serology

Immunoglobulin, IgG, IgA, IgM, IgD and IgE, eosinophilic cationic protein levels are elevated in asthma. Antibodies to CMV, RSV, chlamydia and mycoplasma can be detected.

Microbiologic Examination of Body Secretions

Sputum, nasal cytology, tracheal secretions, throat swab, bronchial aspiration, gastric lavage can be examined microscopically, at times following special stain like Ziehl-Neelsen stain for AFB, and even cultured for exact microbial growth and antibiotic sensitivity in several conditions (Table 21.1).

Skin Tests

These include Mantoux test or BCG diagnostic test for tuberculosis, Kveim test for sarcoidosis, Casoni test for hydatid disease, and skin tests (patch-prick and intradermal tests) for allergens.

Table 21.1: Indication of microbiologic examination of body secretions in diagnosis of respiratory disease

Secretions	Indications
Sputum, tracheal, bronchial, gastric microscopy/culture	Lung abscess, bronchiectasis, cystic fibrosis, tuberculosis, <i>Pneumocystis carinii</i> pneumonia
Nasal cytology for eosinophils	Allergic rhinitis, nasobronchial allergy
Special iron stains of bronchial secretions	Hemosiderosis

Pilocarpine Iontophoresis for Sweat Chloride

A sweat chloride level of over 60 mEq/L in a child with clinical profile of cystic fibrosis establishes the diagnosis. For quick molecular diagnosis of CF, especially for research purposes, polymerase chain reaction (PCR) and DNA studies are now available.

Pulmonary Function Tests

These include:

- Spirometry (the most important) measures forced vital capacity (FVC), forced expiratory volume (FEV1) in one second, FEV1/ FVC ratio, maximal midflow (MMF) between 25% and 75% of FVC or, alternatively, forced expiratory flow (FEF) between 25% and 75% of FVC.
- Mini Wright peak flow meter for evaluation of obstruction and response to bronchodilator therapy
- Bronchial provocation using methacholine and histamine.

Arterial Blood Gas (ABG) Analysis

Arterial oxygen and carbon dioxide levels faithfully reflect the state of ventilation, perfusion and gas exchange. Table 21.2 gives the normal levels.

Table 21.2: Arterial blood gas levels

Criteria	Normal blood level	Blood level in acute respiratory failure
pH	7.35-7.45 mm Hg	
PCO ₂	35-45 mm Hg	> 50 mm Hg
PO ₂	90 mm Hg	< 60 mm Hg

Transillumination

This is a useful simple maneuver to diagnose pneumothorax in an infant under 6 months of age. A large halo of light is seen around the fiberoptic light scope.

Direct Laryngoscopy

This is usually carried out using a fiberoptic or rigid scope under general anesthesia or sedation in the evaluation of an upper airway obstruction or stridor.

Bronchoscopy

The procedure is carried out under general anesthesia employing a fiberoptic or rigid bronchoscope in the following situations:

- Foreign body
- Intractable wheeze
- Recurrent or persistent pneumonia
- Atelectasis
- Immunocompromised state with unexplained interstitial pneumonia
- Hemoptysis
- Lung mass causing pressure symptoms.

Bronchoscopy may serve both a diagnostic and therapeutic purpose.

Thoracoscopy

Thoracoscopy is a useful procedure for evaluating the pleural cavity. The instrument used (thoracoscope) is similar to a bronchoscope.

Thoracocentesis

Intercostal drainage is indicated for obtaining pleural fluid sample for diagnostic purpose and in case of a massive pleural effusion causing dyspnea. It is best done in the 5-7th intercostal space on the posterior axillary line.

Lung Tap

It is needed for obtaining specimen of the pulmonary parenchyma and is done with a needle subsequent to instillation of saline.

Lung Biopsy

This procedure is indicated for diagnosis of *Pneumocystis carinii* and other diffuse lung diseases and may be done either by open surgery or via a bronchoscope or endotracheal tube.

Polygraphic Monitoring

This consists in monitoring of heart rate, ECG, movements of chest and abdomen, arterial PCO₂ and SaO₂

in cases of obstructive apnea and upper airway obstruction.

UPPER RESPIRATORY TRACT INFECTION (URTI) (*Upper Respiratory Catarrh; Common Cold; Rhinopharyngitis, Acute Nasopharyngitis*)

URTI is usually caused by over 150 serologically different viruses, the major share being of the rhinoviruses all of which belong to picornavirus family of small RNA viruses.

Among bacteria, group A *Streptococci* take the lead though *Corynebacterium diphtheriae*, *N. meningitidis*, *Myc. pneumoniae* and *N. gonorrhoeae* may also cause URI. *H. influenzae*, *Pneumococcus* and *Staphylococcus aureus* are responsible for superimposed infection, leading to complications related to ears, sinuses, mastoids, lymph nodes and lungs. Symptoms of asthma may get precipitated or aggravated in a child with reactive airway.

It is a very common ailment and is characterized by inflammation of the upper respiratory tract, resulting in nasal discharge which is only watery or mucoid in majority of the cases. These cases of *mild catarrh*, do not need anything beyond local decongestants like ephedrine nasal drops (0.25 or 0.5%) which are best administered while the child is lying supine with the neck slightly hyperextended, 15 to 20 minutes before feeding and at bedtime. Instillation of 1 to 2 drops 5 to 10 minutes after the primary doses helps to achieve shrinkage of the posterior mucous membrane as well. *Caution:* Continued use of nasal drops for over 4 to 5 days may lead to chemical irritation and congestion simulating acute URI.

In *moderate catarrh*, a patient has purulent nasal discharge, dry cough with postnasal discharge, fever, malaise, anorexia, etc. There may also be adenitis, tonsillitis, pharyngitis and extension of the infection lower down to larynx and bronchi. Ingestion of infected secretions may cause diarrhea and abdominal pain.

Treatment of moderate catarrh is more or less symptomatic. In addition to decongestants, antipyretics and cough mixtures are of value. In case of poor response to these measures, an antibiotic like penicillin, ampicillin, amoxicillin or erythromycin may be used. Whether antibiotic therapy affects the course of illness or cuts short the incidence of bacterial complications is doubtful.

FOREIGN BODY IN LOWER RESPIRATORY TRACT

Toddlers often aspirate foreign bodies such as peanut, almond, groundnut seeds, grains and pulses. Occasionally, small metallic coins may also be inhaled though, more often, these are swallowed.

There is a sudden paroxysm of cough with congestion of the face and almost a state of suffocation. If the foreign body fails to be coughed out, it may cause partial or complete obstruction of a main bronchus. The former results in massive emphysema whereas the latter in massive collapse (atelectasis). A few days later, the child is brought to the hospital with signs and symptoms of pneumonia. Another delay may result in development of the lung abscess, or bronchiectasis.

Diagnosis is from the history of a sudden paroxysm of violent cough, clinical findings of pneumonia, collapse, emphysema, etc. bronchoscopy and radiology (provided it is a metallic foreign body).

Management is aimed at removing the foreign body (in most cases by bronchoscopy) and administration of appropriate antibiotics in case of infection.

ADULT RESPIRATORY DISTRESS SYNDROME (ARDS)

This critical condition seen even in as young an infant as 1-2 weeks, is characterized by acute respiratory distress, and noncardiogenic pulmonary edema as a result of a diffuse lung injury.

Etiopathogenesis

ARDS is caused by a diffuse lung injury. A number of triggering factors, including shock, near-drowning, septicemia, injury, drug overdose, aspiration, inhalation injury and DIC have been incriminated.

Diffuse alveolar damage is the central lesion. The initial or *exudative stage* is characterized by pulmonary congestion and edema and lasts up to 72 hours. The subject may recover or pass on to the chronic or proliferative stage between first and third week after injury and is characterized by an enhanced density of type II pneumocytes and fibroblasts. In due course, type II pneumocytes are transformed into type I pneumocytes and collagen is deposited by stimulation of fibroblasts. The eventual *fibrotic stage* follows after persistence of ARDS for over 3 weeks and is characterized by extensive fibrosis which makes gas exchange difficult.

Cardiorespiratory dysfunction with resultant severe hypoxemia is the most important physiological feature of ARDS. The existence of concurrent abnormalities in the surfactant system predisposes the lungs to develop atelectasis and edema formation.

Clinical Manifestations

Initially, there is only mild respiratory distress and hyperventilation. In the subsequent 4-24 hours, the subject develops hypoxemia and such manifestations as increasing respiratory distress with cyanosis and inspiratory crepitations (crackles). A large intrapulmonary shunt may be demonstrated at this point. Unless the subject receives supplemental oxygen or mechanical ventilation, increasing hypoxemia and hypercapnia prove fatal.

Laboratory Diagnosis

Though evidence of pulmonary edema is available in the X-ray of chest sooner or later, more useful information is obtained from arterial blood gas analyses which shows a $\text{PaO}_2 < 50$ mm Hg or a FIO_2 of > 0.6 %; a $\text{PaO}_2/\text{FIO}_2$ ratio of < 200 correlates with a QS/QT (intrapulmonary shunt) of $> 20\%$.

CT scan shows that most of the pulmonary infiltrates are in the dependent (posterior) part of the lung.

Pulmonary function tests show poor residual capacity and lung compliance.

Pulmonary artery pressure and resistance show varying increase.

Treatment

The cornerstone of management of ARDS is delivery of sufficient oxygen with endotracheal intubation and mechanical ventilation, often with the help of PEEP. This essentially requires the facilities of the intensive care unit (ICU).

Newer therapies are:

- Pressure-controlled ventilation with permissive hypercapnia
- High frequency ventilation including high frequency positive pressure ventilation, high frequency oscillation and high frequency jet ventilation
- Negative pressure ventilation/liquid ventilation

- Extracorporeal membrane oxygenation (ECMO)
- Exogenous surfactant replacement
- Inhaled nitric oxide.

Lung transplant:

- Ecosanoids or their inhibitors
- Vasodilators
- Pentoxifylline
- Steroids (only in advanced stages).

Complications

These include nosocomial infections, septicemia, severe barotrauma, compromised cardiac output, oxygen toxicity, progressive pulmonary fibrosis, multiple system organ failure including acute tubular necrosis, DIC, hepatic dysfunction, cardiomyopathy, gastrointestinal bleed and ileus.

Prognosis

Mortality is very high (50-75%) and is usually the result of initiating causative event, multisystem organ failure or septicemia. The survivors usually revert to preillness status within the following year. Long-term prognosis in pediatric survivors is better than in adult.

RESPIRATORY SYNCYTIAL VIRUS (RSV) INFECTION

Notwithstanding earlier impression, according to the observations of WHO, RSV infection is a common and an important cause of acute lower respiratory infection (ALRI) in infants and children even in the developing countries, resulting in acute bronchiolitis, pneumonia and acute exacerbation of asthma.

ACUTE BRONCHITIS

It is a febrile illness, bacterial or viral in origin, characterized by dry cough (which is worst at night), wheezing and mild constitutional symptoms. Cough becomes productive after about 5 days.

Important chest findings are the widespread rhonchi and coarse crepitations. Some tachypnea is often present.

X-ray chest shows nothing significant except for the increased bronchial markings in some of the cases only.

Treatment consists in giving a suitable antibiotic, a cough expectorant, and an antipyretic. Warm, moist air is of advantage.

With this treatment, most of the patients recover in 7 to 10 days time but cough may continue for a month or so. Chronic bronchitis is seen less frequently in pediatric practice.

ACUTE BRONCHIOLITIS

It is a serious illness, characterized by inflammation of bronchioles, causing severe dyspnea. Infants are the most likely candidates.

Etiopathogenesis

The exact etiology is not clear. In all probability, the etiologic agents appear to be some viruses like virus of primary atypical pneumonia, influenza virus type (A, B and C), adenovirus, respiratory syncytial virus (RSV), herpes virus and parainfluenza virus. Certain bacteria (*H. influenzae*, *Pneumococcus*, *Streptococcus hemolyticus*) and "allergy" have also been incriminated. However, there is no convincing evidence in support of this.

As a result of inflammation, exudate, edema and contraction of the circular musculature of the bronchioles, there occurs a sort of obstruction followed by areas of emphysema and collapse.

Epidemiology

Bronchiolitis is more or less confined to winter and early spring and occurs globally. It is primarily a disease of the first 2 years of life, the peak incidence occurring around 6 months of age. Both epidemic and sporadic forms occur.

Clinical Features

Following a mild upper respiratory infection, the disease abruptly manifests with dyspnea (rapid shallow breathing) and prostration. Cough is either absent or simply mild. Mild to moderate fever is usually present. If dyspnea is marked (which usually is the case), air hunger, flaring of alae nasi and cyanosis may be there. Also, patient may go into dehydration and respiratory acidosis.

Chest signs include intercostal, subcostal and suprasternal retraction, hyperresonant percussion note (this is because of emphysema which may also push

the liver and spleen down) diminished breath sounds and widespread crepitations, and wheezing.

Differential Diagnosis

Acute bronchiolitis requires to be differentiated from asthma (known for frequent exacerbations), bacterial pneumonia (bronchospasm either absent or only mild), foreign body in trachea (history of FB, localized wheeze, signs of collapse/emphysema) and CCF.

Diagnosis

Diagnosis is generally obvious from the clinical presentation and good chest examination.

X-ray chest shows emphysema, prominent bronchovascular markings and small areas of collapse.

Screening reveals low-lying diaphragm with limited movements. Lungs are characteristically overinflated and intercostal spaces are wide.

Complications

These are listed in Table 21.3.

Table 21.3: Complications of acute bronchiolitis

Short-term

1. Rapidly progressive exhaustion, anoxia and death.
2. Dehydration and electrolyte imbalance with respiratory acidosis.
3. Congestive cardiac failure.
4. Bacterial invasion: bronchopneumonia, acute otitis media.

Long-term

1. Bronchiolitis obliterans in which bronchioles are obliterated by nodular masses consisting of granulation and fibrotic tissue. Chest X-ray suggests miliary mottling-like picture.
2. Hyperlucent lung syndrome, also called Swyer-James syndromes.

Treatment

Bronchiolitis is an emergency. The management is mostly symptomatic.

General measures include humidified oxygen inhalation through face mask or head box, atmosphere well saturated with water vapors, mild sedation, postural drainage and intravenous fluids to combat dehydration.

Since exact etiologic diagnosis is practically impossible in clinical practice, an antibiotic cover may be given on the presumption of a causative or superimposed bacterial infection.

Bronchodilators are better avoided since, rather than doing any good, they may increase the cardiac output and restlessness. If indeed indicated, preferred bronchodilation therapy should be in the form of salbutamol or epinephrine (racemic or levo), preferably by nebulization. Steroids are no longer recommended.

Severe bronchiolitis resulting from respiratory syncytial virus is best treated with the antiviral agent, ribavirin (Virazid), available as sterilized lyophilized powder to be reconstituted for aerosol therapy. Treatment is carried out using a small particle aerosol generator (SPAG) for 12 to 18 hours a day for at least 3 days but not more than 7 days. A consistent monitoring of both patient and equipment is vital, especially if the subject is in need of assisted ventilation. Therapy with this agent is expensive, one 6 g vial costing £ 195 (approximately Rs.13,000). Moreover, it is teratogenic. Nevertheless, its administration must be considered in acute bronchiolitis in such diseases as cystic fibrosis (CF), chronic lung disease (CLD), congenital heart disease (CHD), immunodeficiency state and extreme preterm babies.

Prophylaxis

For immunoprophylaxis, see Chapter 10 (Immunization).

Prognosis

Overall prognosis is good. In a few cases (1%) death may occur in spite of best of treatment.

SEVERE ACUTE RESPIRATORY SYNDROME (SARS)

The truly identified cases of this newly-recognized viral disease, first originating in Guangdong province of China in late 2002, were reported in first half of 2003 from Hong Kong, Singapore, Vietnam, United States and Canada among other countries.

Etiology

The causative pathogen is a coronavirus which has seemingly spilled over to human beings from the animals. This RNA virus involves only the respiratory tract cells.

Modes of infectivity include:

- Droplet infection
- Close contact
- Fomites

Hospitals and airtravel play an important role in spread of SARS.

Clinical Features

Clinical presentation of pediatric SARS (as per Center for Disease Control (CDC) is given in Table 21.4.

Table 21.4: Clinical case definition of pediatric SARS

- A. *Clinical criteria*
1. Symptomatic or mild respiratory illness
 2. Moderate respiratory illness
 - Temperature > 100.4°F (38°C), and
 - One or more clinical findings of respiratory illness (e.g. cough, shortness of breath, difficulty breathing, or hypoxia)
 3. Severe respiratory illness
 - Temperature > 100.4°F (38°C), and
 - One or more clinical findings of respiratory illness (e.g. cough, shortness of breath, difficulty breathing, or hypoxia), and
 Radiographic evidence of pneumonia, or Respiratory distress syndrome, or Autopsy findings consistent with pneumonia or respiratory distress syndrome without an identifiable cause
- B. *Epidemiologic criteria*
1. Travel (including transit in an airport) within 10 days of onset of symptoms to an area with current or previously documented or suspected community transmission of SARS, or
 2. Close contact within 10 days of onset of symptoms with a person known or suspected to have SARS

Earlier belief that SARS spares children is no longer well founded. It does occur in children as well. Nevertheless, unlike in adults (especially the elderly in whom it is a serious emergency illness), clinical profile in children is by and large mild. Most children have upper respiratory illness which may be ignored. In moderate respiratory illness (more often in older children and adolescents), fever, cough, shortness of breath or hypoxia is seen. In severe illness, in addition to the manifestations of moderate illness, X-ray chest shows bronchopneumonia or there may well be a frank respiratory distress.

Treatment

See Table 21.5.

Prevention and Infection Control

Though SARS is not a contagious disease, "isolation" and "quarantine" are the two methods that help in containing it.

Table 21.5: Treatment of pediatric SARS

Clinical situations	Treatments
Diagnosis of SARS suspected on admission	Intravenous cefotaxime, oral clarithromycin, and oral ribavirin (40 mg/kg daily, given in two or three doses, 1-2 week)
Fever persists >48 h	Oral prednisolone (0.5 mg/kg daily to 2.0 mg/kg daily, tapered over 2-3 weeks)
Patients with moderate symptoms of high fluctuating fever and notable malaise	Intravenous ribavirin (20 mg/kg daily, given in three doses) and hydrocortisone (2 mg/kg every 6 h) immediately after admission
Persistent fever and progressive worsening clinically or radiologically	Pulse intravenous methylprednisolone (10-20 mg/kg)

PNEUMONIAS

The term, *pneumonia*, refers to infection of the lung parenchyma which may be primary or secondary to acute bronchitis complicating an upper respiratory infection.

Nearly 10% of admissions, in our experience, are accounted by the second.

Classification

I. Etiologic Classification

- Bacterial *Streptococcus pneumoniae* (*Pneumococcus*), *Staphylococcus Streptococcus*, *H. influenzae*, *Klebsiella*, *H. pertussis*, *M. tuberculosis*, *E.coli*
- Viral Influenza, measles, RSV
Chickenpox
- *Mycoplasma* *Mycoplasma pneumoniae*
- Fungal Thrush, coccidiomycosis
histoplasmosis, blastomycosis
- Protozoal *Pneumocystis carinii*
Toxoplasma gondii
Entamoeba histolytica
- Rickettsial Typhus
Rocky mountain spotted fever
- Miscellaneous Aspiration pneumonia (vomitus, amniotic fluid in newborn, drowning, foreign body, chemicals like kerosene oil); Loeffler pneumonia; hypostatic pneumonia.

II. Anatomic Classification

- *Bronchopneumonia* Patchy involvement of lungs.
- *Lobar pneumonia* One or more lobes of lung involved.
- *Pneumonitis* Alveoli or interstitial tissue between them affected. It is more or less a radiologic diagnosis.

III. Classification Based on Acquisition

- Congenital
- Community acquired
- Hospital acquired.

IV. Classification Based on Chronicity

- Acute
- Chronic (*recurrent, persistent*).

Pneumococcal pneumoniae accounts for 90% of bacterial pneumonias in childhood. After first year of life, it is responsible for virtually all bacterial pneumonias.

H. influenzae, and staphylococcal infections occur most often in infancy.

The term, *persistent pneumonia*, denotes a chronic nonresolving pneumonia in which radiologic findings persist for over one month. Predisposing factors are given in Table 21.6.

Table 21.6: Predisposing factors for chronic pneumonia

<i>Immunodeficiency</i>
• PEM
• HIV
<i>Congenital respiratory malformations</i>
• Tracheoesophageal fistula
• Gastroesophageal reflux
<i>Congenital heart disease</i>
• Ventricular septal defect
<i>Defective clearance of airway secretions</i>
• Cystic fibrosis
<i>Chronic pulmonary diseases</i>
• Tuberculosis
• Bronchiectasis
• Asthma

Clinical Features

The onset is usually sudden with high fever, chills, cough and respiratory distress. Active movements of the alae nasi, grunting expiration and lower costal

recession with some cyanosis are alarming manifestations. In some cases, diarrhea, vomiting convulsions and chest pain (referred to abdomen) may be present.

Chest signs of consolidation include diminished movements of affected side, increased vocal fremitus and resonance, dullness, diminished breath sounds, and bronchial breathing. Crepitations denote beginning of resolution. Mind you, there is no shifting of mediastinum.

Chest signs of bronchopneumonia include tachypnea, normal or harsh breath sounds and diffuse crepitations spread all over both lungs.

World Health Organization (WHO) has recommended that very fast breathing, especially in association with cough, difficult breathing or indrawing of chest, must always be considered a reflection of pneumonia, unless proved otherwise. Fever undoubtedly causes elevation in respiratory rate. But, the effect is only weak, say 2 to 3 breaths per one degree celsius rise above 37°C per minute. The cut-off point for high respiratory rate is over 60 per minute up to 2 months of age, over 50 per minute between 2 months to 12 months, and 40 per minute between 12 months to 5 years.

In debilitated infants and children, despite the presence of extensive pneumonia, signs and symptoms may not be as classical as described above. The diagnosis of pneumonia in such cases is often made following detailed examination and a chest radiograph.

Presence of certain predisposing factors (Table 21.7) should arouse suspicion for staphylococcal pneumonia.

Table 21.7: Predisposing factors for staphylococcal pneumonia

- Infectious diseases of childhood such as measles and chickenpox
- Staphylococcal infections elsewhere in the body, e.g. skin (furunculosis), throat, etc.
- Debilitating illnesses, e.g. advanced protein-energy malnutrition (PEM), cystic fibrosis, malignancies, etc.
- Hypogammaglobulinemia
- Immunosuppressive therapy

Complications

These include:

- Pleural effusion or emphysema
- Collapse

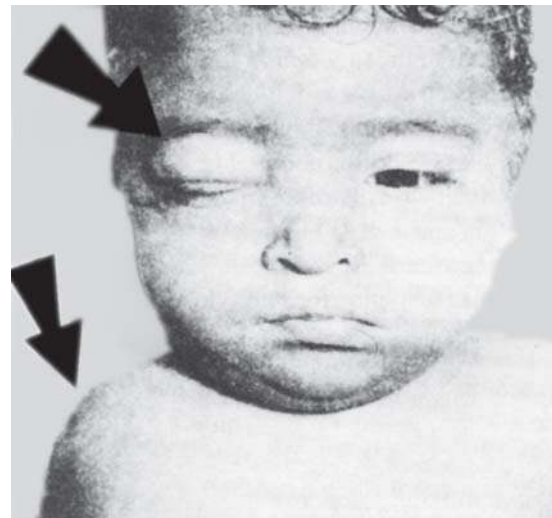

Fig. 21.1: Subcutaneous emphysema in an infant with bronchopneumonia

- Pneumatocele
- Lung abscess,
- Bronchiectasis
- Subcutaneous emphysema (Fig. 21.1).
- Metastatic spread: Meningitis, septic arthritis, osteomyelitis, etc.

Of the various types, staphylococcal pneumonia carries the worst prognosis.

Diagnosis

Besides clinical suspicion, an X-ray chest (PA view, ordinarily) is most reliable to detect the type and extent of lesions. X-ray finding suggesting bronchopneumonia include diffuse patchy consolidations, usually involving both lungs. X-ray finding, suggesting lobar pneumonia (consolidation) include a homogeneous opacity occupying the anatomic area of a lobe without any mediastinal shift, usually involving only one lung.

Detection of pleural effusion, pyopneumothorax or pneumatoceles (small inflated abscesses) highly favor the diagnosis of staphylococcal pneumonia (Figs 21.2 and 21.3). Nonradiopaque foreign bodies may produce multiple abscesses or pneumatoceles, resulting in a radiologic picture simulating that seen in staphylococcal pneumonia. Miliary mottling constitutes another important differential diagnosis.

Recurrent pneumonia must arouse suspicion of the following conditions:

- Abnormalities of antibody production such as agammaglobulinemia.

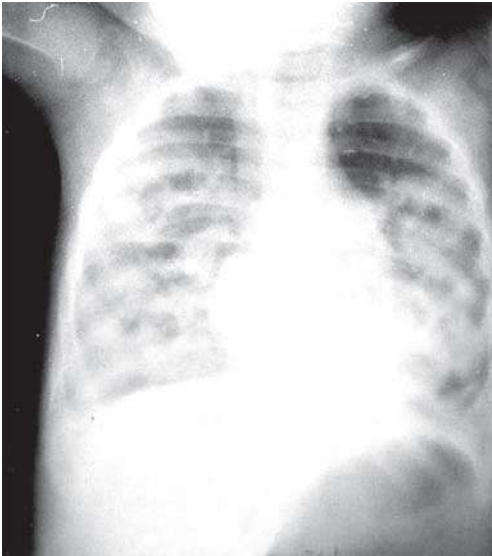

Fig. 21.2: Staphylococcal pneumonia: Demonstration of pneumatoceles is regarded pathognomonic of staphylococcal pneumonia. It usually occurs during infancy secondary to staphylococcal infection elsewhere in the body. Unless, treated energetically, serious complications are a rule

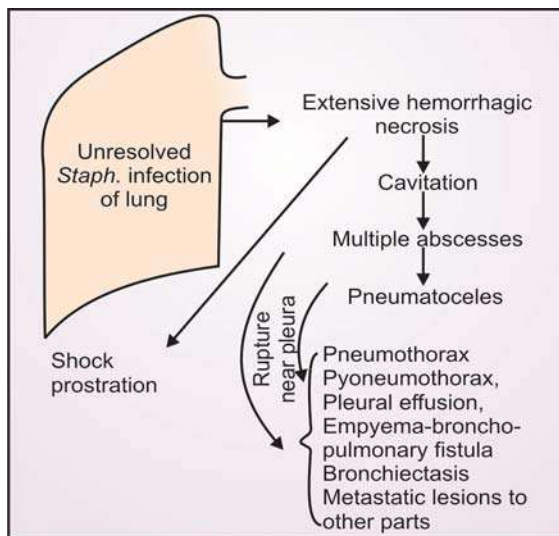

Fig. 21.3: Natural history of development of complications in staphylococcal pneumonia

- Cystic fibrosis (CF)
- Cleft palate
- Congenital bronchiectasis
- Immotile cilia syndrome
- Tracheoesophageal fistula
- Abnormalities of polymorphonuclear leukocytes
- Neutropenia
- Increased pulmonary blood flow
- Deficient gag reflex

- Foreign body
- Tuberculosis.

Treatment

Antibiotics in Community-acquired Pneumonia

A specific antibiotic agent is dictated by the anticipated causative agent rather than the anatomic type of pneumonia.

Penicillin is the drug of choice for pneumococcal pneumonia (*Streptococcus pneumoniae*) which is the usual pneumonia encountered in children beyond 1 year of age. In uncomplicated cases, it leads to dramatic response, causing complete resolution in 7 to 14 days.

In case of penicillin hypersensitivity, a cephalosporin like cefazolin makes an appropriate alternative agent.

Emergence of multidrug resistance strains (MDRS) of *Streptococcus pneumoniae* (that causes not only pneumonia but also acute otitis media (AOM), acute sinusitis, acute bronchitis, etc.) may turn out to be a therapeutic challenge in the developing countries. These resistant strains fail to respond to penicillin and other beta-lactams and non-beta-lactams, including cephalosporins. In such a situation, it is advisable to consider use of a beta-lactamase inhibitor along with a beta-lactam, say amoxicillin-clavulanate (Augmentin) or ampicillin-sulbactam (Sulbacin, Betamp) for a gratifying outcome.

In case of *staphylococcal pneumonia*, a penicillinase-resistant penicillin (cloxacillin) plus ampicillin or gentamicin is the best choice. Alternatively, vancomycin or clindamycin may be employed.

For *H. influenzae*, ampicillin alone or a combination of penicillin plus chloramphenicol is recommended.

More recently, it has been suggested that ampicillin plus chloramphenicol or ceftriaxone must be incorporated in the initial therapy of *H. influenzae B* pneumonia.

For *Klebsiella*, a combination of penicillin plus kanamycin or gentamicin is the therapy of choice.

For *Pseudomonas pneumonia*, treatment of choice is ticarcillin alone or in combination with gentamicin or kanamycin.

Pneumocystis carinii pneumonia (interstitial plasma cell pneumonia) needs to be treated with cotrimoxazole in very high doses (20 mg/kg/day with reference to trimethoprim).

Thrush pneumonia (pulmonary candidiasis) responds well to only amphotericin B or 5-fluorocytosine.

Tuberculous pneumonia requires antituberculous therapy (ATT) which is discussed elsewhere in this very chapter.

Viral pneumonia responds to ribavirin aerosolization in case of respiratory syncytial virus (RSV) and amanta-dine (rimantidine) in case of influenza A isolates.

Loeffler pneumonia (*Loeffler syndrome*) resulting from the certain larvae when they pass through lung during the life cycle of nematodes is purely symptomatic.

Primary atypical pneumonia resulting from *Mycoplasma pneumoniae* is treated with erythromycin or tetracyclines in case of grown-up children.

For aspiration pneumonia, use of prophylactic antibiotics is usually recommended.

Needless to say, these recommendations are subject to changes which may be warranted following receipt of culture and sensitivity report.

Antibiotics in Hospital-acquired Pneumonia

Recommended drugs vary with the likely pathogen(s): *Gram negative bacilli*: Generally, aminoglycosides (gentamicin, netilrucin, amikacin). for *Klebsiella*, 3rd generation cephalosporins. For *P. aeruginosa*, ticarcillin with clavulianate, ceftazidime or quinolones. *Staph aureus*: Vancomycin or cloxacillin; quinolones and cefazolin are good alternatives.

Anaerobes: Metronidazole and clindamycin.

General Measures

- Good nursing care
- Bed rest
- Suction to remove secretions from tracheobronchial tree
- Oxygen
- Symptomatic treatment for cough, restlessness, fever and pain
- Adequate fluid and dietary intake
- Treatment of congestive cardiac failure, if present.
- Physiotherapy: Breathing exercise during recovery are of value.
- Surgical intervention may be needed in subjects who have developed complications like empyema or tension pneumothorax, a fairly common occurrence in staphylococcal pneumonia.

Finally, a word of caution. The widespread practice of employing sodium bicarbonate in cases of tachypnea (unless accompanied by documented metabolic acidosis) must be discouraged. Such an administration may prove counterproductive by causing respiratory alkalosis.

Prognosis

Prognosis is generally good following appropriate treatment "in time".

BRONCHIECTASIS

Definition

Bronchiectasis is defined as a permanent dilation of the bronchi and bronchioles, as a result of obstruction and/or infection. Consequent to this, there is cavitation of the bronchial wall and tissue destruction. Collapse, emphy-sema and pneumonia usually accompany bronchiectasis.

Etiopathogenesis

As already mentioned, bronchial occlusion and inflammation over a prolonged period form the cornerstone of the natural history of bronchiectasis. If the occlusion is significant, there results collapse distal to and dilation proximal to the site of obstruction. Partial obstruction first causes emphysema in the distal part. But, with passage of time and further progression of the lesion, coupled with repeated infections, ultimately the classical picture results.

Depending on the shape of the dilated part, bronchiectasis has been classified as *saccular*, *cylindrical* or *fusiform*.

In a large majority of the children, it is unilateral, generally involving the posterior basal segment of the left lower lobe.

The common conditions with which bronchiectasis may be associated or which it may follow are:

- Obstruction due to foreign body.
- Obstruction due to collection of thick mucus as in cystic fibrosis, bronchial asthma or chronic bronchitis.
- Infections e.g. measles, pertussis, pneumonia (staphylococcal, in particular), sinusitis or tuberculosis.

In addition to acquired bronchiectasis, the disease may occur secondary to congenital collapse.

The so-called *Kartagener syndrome* is characterized by dextrocardia (usually with situs inversus), chronic bronchitis with bronchiectasis at a later stage and sinusitis. Bronchiectasis occurs rather late, usually in early 20s. Chronic bronchitis is what is usually encountered in childhood. Chronic otitis media like chronic sinusitis is common. Survivors have high incidence of sterility. The origin of the syndrome is ascribed to generalized defect of ciliary motility right from the embryonal stage. Hence, the nomenclature, *immotile cilia syndrome* or *dyskinetic cilia syndrome*.

The most common organism found in the sputum of children with this disease is staphylococcus.

Clinical Features

The onset is usually insidious with persistent or recurrent cough, productive of copious mucopurulent sputum. The latter is foul-smelling and has postural relationship. Likewise, patient's breathing also carries bad smell. Some fever and recurrent attacks of respiratory infections are frequent.

In advanced cases, dyspnea, cyanosis, clubbing and hemoptysis may also be present.

The characteristic auscultatory finding is the "localized crepitations", repeatedly found over the affected area. Other signs suggestive of collapse-consolidation may also be present.

Diagnosis

- Clinical suspicion
- *Radiology*: X-ray chest shows increased bronchovascular markings, extending towards the base of the lung. Later, areas of cavitation may become apparent.
- *Bronchography* (it should be preceded by bronchoscopy) is essential to localize and establish the extent of bronchiectasis.
- Bacteriologic examination of sputum or secretions.

Treatment

- Appropriate antibiotic cover: Systemic antibiotics are to be preferred.

- Postural drainage: The use of bronchodilator aerosol is of added advantage in this behalf.
- Breathing exercises.
- Surgical intervention to remove the affected lobe(s), provided that medical treatment, given over a 12 months period, has failed.

Prognosis

With the aforesaid regimen, prognosis is generally good.

DRY PLEURISY (*Plastic Pleurisy*)

In this condition small serous fluid and adhesions develop between the pleural surfaces, at times severe enough to inhibit lung movements.

Etiology

The causes include upper and lower respiratory infections, tuberculosis, acute rheumatic fever and other mesenchymal diseases.

Clinical Features

On top of the manifestations of the primary disease, the child has pleural pain which gets exaggerated by deep breathing and may be referred to the shoulder or the back. As a result of pain, grunting and guarding of respiration may develop, compelling the child to lie on the affected side.

Physical examination shows some dullness on percussion and diminution of breath sounds in case of thickened pleura or a thick layer of exudate. A rough to and fro friction sound, *pleural rub*, may be heard early in the disease. Often, pleurisy may be asymptomatic.

Diagnosis

X-ray chest show a diffuse haziness at the pleural surface or a dense well-defined shadow.

Differential diagnosis includes pleurodynia, rib fracture, herpes zoster, etc.

Treatment

This is primarily of the underlying disease.

PLEURAL EFFUSION

It is the collection of serous fluid (in empyema, it is the thick purulent fluid, i.e. pus) in the pleural cavity

(between parital and viseral pleura) Pleural effusion is relatively less frequent in children; almost all cases are seen beyond 5 years of age. Pleural fluid may be transudate (clear with protein < 3g% and no cells) or exudate (straw-colored with protein > 3 g% and lymphocytes) (Table 21.8).

Table 21.8: Differences between pleural transudate and exudate

Parameters	Transudates*	Exudates	
		Tuberculous	Pyogenic
Appearance	Clear	Straw-colored	Turbid
Protein	< 3 g/dl	> 3g/dl	> 3 g/dl
Pleural fluid protein/ serum protein ratio	< 0.5: 1	> 0.5: 1	> 0.5: 1
Pleural fluid LDH/ serum LDH ratio	< 0.6: 1	> 0.6: 1	> 0.6: 1
pH	> 7.2	< 7.2	< 7.2
Glucose	> 40 mg/dl	< 40 mg/dl	< 40 mg/dl
Cellularity	Absent	Lymphocytes	Polymophs

* May accompany nephrotic syndrome, CCF, cirrhosis, anemia with hypoproteinemia, kwashiorkor

Etiology

Tuberculosis is responsible for majority of the cases followed by pneumonia, CCF, constrictive pericarditis and hypoproteinemic states (nephrotic syndrome, kwashiorkor, protein-losing enteropathy, hepatic failure). In a small proportion, thoracic lymphoreticular malignancy may be the cause.

Pleural effusion results from discharge of the caseous material of a peripheral (subpleural) primary focus or enlarged regional lymph node. Hematogenous, or local spread as also allergic reaction to tuberculous proteins too can cause pleural effusion.

Clinical Features

Onset is usually subacute with such manifestations as high fever, cough, chest pain on affected side (that worsens on deep breathing and coughing), reflex abdominal pain in case of basal effusion and weight loss. Breathlessness may occur depending on rapidity of accumulation and magnitude of effusion.

Physical examination reveals decreased chest movements on affected side, mediastinal shift to the opposite side, fullness of the intercostal spaces, decreased vocal

fremitus, stony dull percussion note, pleural rub, decreased vocal resonance, and decreased breath sounds. Above the effusion level, egophony (marked hyper-resonance due to compensatory emphysema) may be elicited. Percussion note in axilla may be at a higher level. This is what is termed *Ellis curve*.

Diagnosis

X-ray chest shows a uniform opacity with a curved fluid line which may become horizontal when air is also coexisting (Fig. 21.4). There is a definite mediastinal shift to the opposite side.

Ultrasonography assists in localizing the fluid better.

Pleural tap (Chapter 43) and examination of the fluid confirms the diagnosis. Straw-colored fluid with high protein content and lymphocytic response (exudate) strongly favors tuberculous pathology.

Treatment

Specific chemotherapy depends on the etiology of pleural effusion, most cases needing antituberculous therapy.

Therapeutic thoracentesis (also called 'thoracocentesis') is indicated in case of large pleural effusion causing respiratory distress. As a rule, quantity of aspiration should not exceed 20-30 ml.

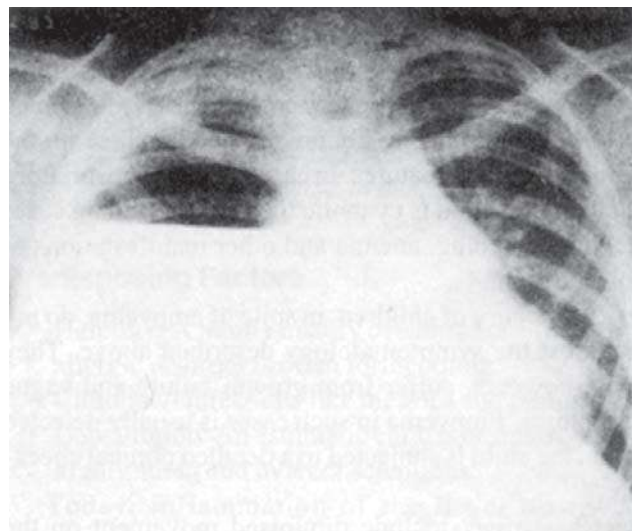

Fig. 21.4: Pleural effusion. Note the horizontal fluid line due to presence of air on top of effusion. Pure effusion causes uniform opacity with curved upper border

EMPHYEMA THORACIS

Empyema means collection of thick pus in the pleural cavity. It is fairly common in infancy.

Etiology

The most common organism responsible for empyema is *Staphylococcus*. The *Streptococcus pneumoniae*, *H. influenzae*, and even *Mycoplasma* also account for a proportion of the cases.

Usually it is the outcome of a complication of:

- Pneumonia (usually staphylococcal)
- Lung abscess
- Bronchiectasis
- Subdiaphragmatic abscess/Liver abscess
- Septicemia
- Metastatic spread of suppurative foci from distant lesions such as osteomyelitis.

Clinical Features

Clinical manifestations, if present, are those of pneumonia. Fever, dyspnea, cough, chest pain (which may be referred to the abdomen), and toxemia are the usual presenting features. In case of marked respiratory distress, the child is cyanotic too. Long-standing cases develop clubbing, anemia and other manifestations of malnutrition.

A category of children, in spite of empyema, do not manifest the symptomatology described above. They may, however, suffer from growth failure and vague symptoms. Empyema in such cases is usually detected when the child is subjected to a detailed clinical check-up.

Chest signs are similar to pleural effusion and include diminished movement on the affected side, widening and dullness (at times edema) of the intercostal spaces, dull percussion note, reduced vocal fremitus and vocal resonance, diminished air entry* and mediastinal shift to the opposite side.

It is worth remembering that empyema must be ruled out in any infant with localized dullness of the percussion note.

The term, *empyema necessitante*, implies a pulsatile swelling over the chest.

* Unlike in adults, an infant's breath sounds may be heard in spite of considerable empyema thoracis

Complications

- Bronchopleural fistulas
- Pyopneumothorax
- Purulent pericarditis
- Pulmonary abscesses
- Peritonitis
- Osteomyelitis of ribs
- Meningitis
- Arthritis
- Septicemia.

Diagnosis

- Clinical suspicion
- *X-ray chest*: In addition to the mediastinal shift to the opposite side, it shows a diffuse density suggestive of pleural fluid. In most of the cases, the opacities are basal and costophrenic angle is obliterated. Loculated empyema may, however, occur in the fissures or at the apex.

Diagnostic pleural tap: The fluid is purulent (turbid) and should be examined biochemically (for high protein and low sugar) as also bacteriologically (for causative pathogens)

Treatment

- *Antibiotics* should be started as soon as the diagnosis has been arrived at. Staphylococcal empyema is best treated with systemic penicillin G or, in case of penicillinase-producing organisms, with cloxacillin or vancomycin. Pneumococcal empyema shows a gratifying response to penicillin G. For *H. influenzae* empyema, ampicillin or chloramphenicol is recommended. Response to staphylococcal empyema is slow. Antibiotic therapy should, therefore, be continued for 3 to 4 weeks.
- *Closed continuous intercostal drainage* is strongly recommended. It needs to be controlled by underwater seal or continuous suction. Controlling empyema by this method should be the choice rather than the multiple aspirations of the pleural cavity.
- *Surgical drainage* after rib resection (thoracotomy or thoracotomy) may be resorted to:
 - in case of severe respiratory difficulty,
 - when improvement fails to occur after 3 weeks,
 - in loculated pus, or
 - in the presence of marked mediastinal shift.

In addition to the aforesaid, symptomatic measures, as and when needed, should be resorted to.

Prognosis

Empyema is a serious disease. Before antibiotic era, the prognosis used to be very bad. Today, following proper treatment "in time", prognosis is excellent in the long-run though some cases may be left with restrictive disease.

LUNG ABSCESS

In India and other developing countries, lung abscess is relatively common.

Etiology

4 *Single abscess* Usually due to pneumonia, tuberculosis or foreign body and, occasionally, following rupture of amebic liver abscess into lung or superadded infection of hydatid cyst.

Multiple abscesses Usually due to pneumonia, tuberculosis, cystic fibrosis, fungus infection, leukemias, agammaglobulinemia, etc.

If an abscess fails to resolve, it may cause pleurisy, pleural effusion or empyema.

Clinical Features

Acute abscesses usually develop during the course of staphylococcal pneumonia and resolve spontaneously with suitable treatment.

Chronic abscesses have insidious onset with fever, persistent cough and foul-smelling sputum. At times, dyspnea and chest pain may be there. Clubbing develops, if the patient remains without treatment over a prolonged period.

Chest signs are usually those of consolidation with bronchial breathing.

Diagnosis

X-ray chest shows characteristic opacities. The cavities may show fluid levels.

Treatment

- Appropriate antibiotics
- Postural drainage

- Breathing exercise
- Surgical resection of the particular segment or lobe should only be done when the medical measures have failed. Surgical drainage is obsolete now.

BRONCHIAL ASTHMA (Reactive Airway Disease)

Definition

Bronchial asthma, now regarded as a chronic inflammatory disorder of the lower airway is characterized by bouts of dyspnea (predominantly "expiratory"), as a result of temporary narrowing of the bronchi by bronchospasm, mucosal edema and thick secretions. Most cases have had its origin in the very first 2 years of life. The peak incidence is, however, seen in 5 to 10 years of age group. Boys suffer twice as much as the girls. The illness too is more severe in them. Incidence in school-going age is around 2%.

Etiopathogenesis

Triggers/Excitatory Factors

- *Allergy to certain foreign substances:* (a) inhalants like pollen, smoke, dust* and powder, (b) foods like egg, meat, wheat and chocolate, (c) food additives, and (c) drugs like aspirin and morphine. In majority of the asthmatics, it is, however, difficult to find the causative allergen.
- *Respiratory infection:* Usually a viral infection causes mucosal edema and mucus secretion that result in narrowing of the airway.
- *Emotional disturbances:* A "row" with the siblings or the parents and "fear" of punishment, may operate through vagus and cause bronchospasm.
- *Exercise:* Role of exercise/exhaustion is well-known in the so-called "exercise-induced asthma". Loss of heat and water from the lower airways leads to a state of mucosal hyperosmolarity. The latter causes release of mediator from the mast cells which result in bronchospasm.
- *Change of climate/weather:* This acts through two mechanisms, namely sudden release of airborne

* The house-dust mite, *Dermatopagoides pteronyssinus*, has now been implicated as probably the most important cause of the allergenicity of the house-dust

allergens in the environment and loss of heat and water from the lower airways.

- *Puberty changes*: Endocrinal changes at puberty are known to enhance symptoms of asthma in adolescents.

Predisposing Factors

- Heredity: A family history of asthma or some other allergic disorder is often forthcoming.
- Childhood infections like measles and pertussis.
- Constitution: An asthmatic child is basically labile, highly stung and overconscientious.

Pathophysiology

Factors ending up with lower airway obstruction in asthma include:

1. Mucosal inflammation (especially edema)
2. Excessive mucosal secretions (mucus, inflammatory cells, cellular debris)
3. Bronchial hyperresponsiveness with bronchospasm

Three types of asthma are:

1. *Extrinsic*: This is IgE-mediated and precipitated by an allergen
2. *Intrinsic*: This is non-IgE-mediated and precipitated by a respiratory infection (usually, viral)
3. *Mixed*: This is usually exercise-induced or aspirin-induced

Following exposure to an allergen which interacts with specific mast cell bound IgE, reaction occur in two phases:

1. *Early Phase/Reaction*: Within minutes, mast cell release histamine, leukotriens C, D and E, prostaglandins, platelet activating factor and bradykinin, causing mucosal edema, secretion and bronchospasm. The net result is lower airway obstruction. Premedication with beta₂-agonists can inhibit this phase.
2. *Late Phase/Reaction*: This is characterized by clinical manifestations of asthma. It follows 3-4 hours later with release of mast cell mediators. Unlike the early phase, beta₂-agonists cannot inhibit it. However, steroids are capable of inhibiting it.

Over and above "inflammation", two additional factors may contribute to development of hyper-reactivity of the lower airway, namely:

- Intrinsic defect in the airway, and
- Abnormal neural control of the airway.

Pathology

Inflammation of the lower airway is considered to be the "cornerstone" of the basic pathology of asthma. The inflammatory changes are characterized by infiltration of the mucosa and epithelium with activated mast cells, T cells and eosinophilia. The mediators of inflammation (leukotriens) released by the mast cells damage the wall of the airway, causing epithelial shedding and mucus secretion.

The so-called "bronchial hyperreactivity" accompanied by bronchospasm involving smooth muscles is now regarded as secondary to inflammation. Defect in the airway and abnormal neural control of the airway may also contribute to its development. A platelet activating factor (PAF), supposed to be formed by the inflammatory cells, causes bronchial hyper-reactivity.

The net result of inflammation and bronchospasm is characteristic wheeze and respiratory distress. Poorly controlled disease results in collapse and emphysema. Rarely, bronchiectasis may occur.

Clinical Features

The onset of an asthmatic paroxysm is usually sudden and often occurs at night. Occasionally, it is preceded by the so-called *asthmatic aura* in the form of tightness in the chest, restlessness, polyuria or itching.

A typical attack consists of marked dyspnea, bouts of cough and chiefly "expiratory wheezing". Cyanosis, pallor, sweating, exhaustion and restlessness are often present. Pulse is invariably rapid.

The fulminant attack may subside in an hour or two, sometimes with vomiting or "coughing up" of viscid secretions. Some expiratory wheezing may, however, continue over several days though the child is otherwise comfortable.

Generally, recurrent asthmatic attacks last over 2 to 7 or 10 days. Then there is an interval of freedom which may vary from a few days to few months.

Children with severe bronchial asthma over a prolonged period may develop a *barrel-shaped* chest deformity.

Box 21.1 gives salient clinical features of acute exacerbation of asthma.

Box 21.1: Clinical spectrum of acute exacerbation of asthma

Definition

An increase in manifestation of asthma in the form of cough, wheeze and/or breathlessness.

Types

1. *Mild*: Cough, tachypnea and wheeze without any chest indrawing and difficulty in speech and feeding. Oxygen saturation >95%. PEFR > 80%.
2. *Moderate*: Cough, tachypnea and wheeze together with chest indrawing, difficulty in speech and feeding, pulsus paradoxus. PEFR and oxygen saturation are reduced. Sensorium is normal.
3. *Severe*: Cyanosis, poor respiratory effort, silent chest, fatigue, altered sensorium. Oxygen saturation and PEFR may be markedly reduced (say <90% and 30%, respectively).

A *peak expiratory flow (PEFR) meter* is very useful in confirming diagnosis of asthma. The child suspected to be having the disorder is made to stand and breath in deeply. Then, he breathes out quickly and hard right into the PEFR meter. The process is repeated thrice and highest of the three readings ascertained for its normally or low level. If the reading is low, the diagnosis of asthma can further be confirmed by *bronchodilator reversibility test* and *steroid test* in case bronchodilator therapy fails to cause improvement in the reading. If PEFR reading is normal and yet you are strongly suspecting asthma, diurnal variation test and exercise test may be carried.

Complications

- Emphysema (commonest)
- Collapse (middle lobe on right side)
- *Cor pulmonale*
- Pneumothorax
- Bronchiectasis
- Tuberculosis in patients on prolonged steroid therapy.

Management of Acute Exacerbation of Asthma

A. Specific Measures (Tables 21.9 and 21.10)

Acute Mild Exacerbation

- Beta₂ agonists (oral, inhalation (MDI with spacer) or nebulization)

4 Diagnosis

It is usually clear from the clinical profile. All attempts should be made to detect the responsible *allergen*. Bronchial asthma should, in particular, be differentiated from cardiac asthma (left heart failure), asthmatic bronchitis, foreign body inhalation, acute bronchiolitis, tropical eosinophilia, whooping cough, and “wheeze” associated with ascariasis, filariasis and mediastinal lymphadenopathy in tuberculosis or lymphoma. Chronic bronchitis, though uncommon in children, may closely simulate bronchial asthma.

Table 21.9: Drugs employed in asthma

Drugs	Oral dose	Parenteral dose	Aerosol dose
Beta-2 adrenergic agonists			
Salbutamol (Albuterol)	0.1 mg/kg/dose 3 to 4 times/day	7.5 mcg/kg in 5 to 10 min, then 0.1 mcg/min, increase	100 to 200 mcg (1 to 2 puffs) every 1 to 5 hrs every 15 min by 0.1 mcg/kg upto 0.4 mcg/kg/min (IV)
Metapreterenol (Orceprenaline)	0.3 to 9.5 mg/kg/dose 3 to 4 times/day		650 mcg (1 or 2 puffs)
Terbutaline	0.075 mg/kg/dose	0.005 mg/kg dose (IV) 3 to 4 times/day	250 mcg (1 or 2 puffs)
Theophyllines			
Aminophylline	4 to 6 mg/kg/dose	6 mg/kg followed 3 to 4 times/day	by 0.9 mg/kg/hr
Theophylline	4 to 5 mg/kg/dose 3 to 4 times/day		
Steroids			
Prednisolone	1 to 2 mg/kg/day		
Hydrocortisone		8 to 10 mg/kg followed by 1 mg/kg/hr or 3 mg/kg every 6 hr	
Beclomethasone			1 to 2 puffs 3 to 4 times/day maximum 10 puffs/day
Ketotifen	0.25 to 0.5 mg BD		1 to 2 puffs 6 hrly; 1 to 2 puffs 20 minutes before exercise in EIA
Cromoglycate			

Table 21.10: Various types of inhalation devices

Metered Dose Inhaler (MDI) This aerosol asthma therapy needs good hand-lung coordination and is, therefore, suitable only for children aged 6 years and beyond (Fig. 21.5). The asthma therapy that is appropriate for administration by MDI include beta-2-adrenergics (salbutamol, terbutaline), atropine derivatives (ipratropium bromide), steroids (beclomethasone, budesonide), and cromoglycate sodium. The dose is administered by taking a puff for 5 to 7 seconds which can be repeated, if the need be, after a gap of one minute. It cuts short the dose by 10 to 15 times and the action begins within just 5 minutes. Side effects of the drug are minimized.

Space Device Inhaler (Spacehaler) This devices overcomes the shortcoming of simple MDI and may be in the form of a valved reservoir or inflatable reservoir bag (Fig. 21.6). It has to be attached to the MDI. It can be used even in children under 3 years. The drug delivery is through a mouthpiece (Fig. 21.7). The device safeguards against deposition of drug particles over pharynx by impaction, thereby reducing the incidence of hoarseness and *Candida* infection accompanying inhalation therapy.

Dry Powder Devices (Rotahaler, Spinhaler, Turbuhaler): These devices do not need patient's cooperation and are supposed to be useful even in children under 5 years of age (Fig. 21.8). However, in actual practice, this does not seem to hold good. Rotahaler is employed for steroid and beta 2-agonist therapy, spinhaler for cromoglycate and turbuhaler for prophylactic steroid therapy.

Nebulizers Nebulization comprises passage of gas at high velocity, leading to formation of particles of (25 microns at least) a specific size (Fig. 21.9). It is best suited in very sick subjects with acute asthma and in very young infants and children who are not in a position to synchronize. Drugs available for nebulization are beta-2-agonists (salbutamol, terbutaline), steroids and cromoglycate. Nebulization should be for period of 5 to 10 minutes at a time. Often, a second nebulization after 2 minutes with a maximum of 6 doses with a maintenance dose at 4 to 6 hours interval for 2 to 3 doses is required.

- Prednisolone, 1-2 mg/kg/day (O) or inhalation steroids
If no improvement, follow regimen for moderate exacerbation.

Acute Moderate Exacerbation

- Oxygen inhalation until oxygen saturation > 95%
- Nebulization with beta-2 agonists, every 20 minutes for one hour, then 4-6 hourly
- Prednisolone, 1-2 mg/kg (O) stat and then daily for 5-7 days.

**Fig. 21.5:** Meter dose inhaler (MDI)**Fig. 21.6:** Space device inhaler (Spacer, Spacehaler). It needs to be attached to the MDI and is even suitable for children below 3 years**Fig. 21.7:** Baby mask attached to the space inhaler which again needs to be attached to the MDI. This device renders the MDI useful even for the infants



Fig. 21.8: Dry powder inhaler (Rotahaler)



Fig. 21.9: Nebulizer therapy is the most effective means of treating a severe attack of asthma, especially when the patient is an infant or a very sick child not able to synchronise

4

If no improvement, follow treatment for acute severe asthma (vide infra).

Acute Severe (Life-threatening) Exacerbation

- Immediate oxygen inhalation,
- Subcutaneous injection of adrenaline
- Nebulization with beta-2 agonists (salbutamol, terbutaline), every 20 minutes and
- IV hydrocortisone, every 6-8 hourly.

If no improvement, a loading dose of IV theophylline is given.

In cases refractory to this treatment, IV magnesium sulfate (50%, 0.2 ml/kg as infusion in 30 ml of 1/5th normal saline in 5% dextrose over 35 minutes) give gratifying results. Magnesium sulfate acts both by anti-inflammatory and bronchodilator effect. Minor side-effects of this therapy include tingling, numbness, flushing, warmth, malaise, etc. Hypermagnesemia (serum magnesium 5 mg/L or 2.5 mmol/L) may manifest with hyporeflexia, hypo-tension and drowsiness. Severe hypermagnesemia (serum magnesium 12 to 15 mEq/L or 6 to 7.5 mmol/L) may cause respiratory depression, coma and even death.

Absence of improvement despite all this is an indication for

- Attention to such factors as coexisting acidosis, dyselectrolytemia and superadded infection
- Mechanical ventilation in PICU.

B. Additional Measures

1. Mild sedation with phenobarbital (morphine is contraindicated) or tranquilizers like chlorpromazine and chlordiazepoxide to allay anxiety and emotional stress,
2. Expectorants to remove excessive secretions,
3. Antibiotics in the presence of infection which is frequent,
4. Maintenance of fluid and electrolyte balance; correction of metabolic acidosis (if documented) with soda bicarbonate.

Management of Status Asthmaticus

Status asthmaticus is defined as a state in which an asthmatic patient continues to suffer from dyspnea in spite of administration of sympathomimetic agents as well as aminophylline/theophylline. He is a candidate for receiving treatment in an intensive care unit.

Employing the respiratory scoring system (Table 21.11), the severity of his problem should be graded as below:

Score 0 to 4	No immediate danger
Score 5 to 6	Impending respiratory failure
Score 7 or above	Respiratory failure

Table 21.11: Clinical respiratory scoring system

Criteria	Scores		
	0	1	2
PaO ₂ mmHg (torr) or Cyanosis	70 to 100 Nil	Under 70 in room air	Under 70 in 40% O ₂
Inspiratory breath sounds	Normal	Unequal	Decreased or absent
Use of accessory muscles of respiration	Nil	Moderate	Marked
Expiratory wheeze	Nil	Moderate or nil because of poor air exchange	Extreme of
Mental status (Cerebral function)	Normal	Depressed	Coma or agitated

Respiratory score is recorded at the very outset and then monitored at regular intervals. At score 5 to 6 or above, all arrangements for assisted ventilation should be kept ready.

Management of Asthma inbetween Acute Exacerbations

During the period in between attacks, attempts should be made to detect the offending allergen, to avoid this and, if possible, to hyposensitize the patient.

“Asthma preventers” (ketotifen, cromoglycate, steroids) may be used in chronic asthma to prevent acute exacerbation.

Since, infection is an important excitatory factor, it should be controlled at the earliest opportunity. Also, seats of infection, i.e. tonsils, adenoids, nasal polyp, etc. should be removed.

Physiotherapy regarding breathing and postural exercises gives gratifying results.

Reassurance to an emotionally disturbed child is very important. He may have to attend a *Child Guidance Clinic* regularly.

A change of environment may remove the offending allergen and also the functional stimuli.

Among the *recent developments* in asthma rank introduction of drugs that block the synthesis of leukotrienes, the mediators secreted by inflammatory cells, namely:

- LTD₄ antagonists: Zafirlukast, Pobilukast, Prenlukast, Tomelukast, Verlukast available under the trade name “Accolate” as 20 mg tablets.

- 5-Lipoxygenase inhibitors: Zileuton, available under the trade name “Zyflo” and “Leutrol” as 60 mg tablets.
- Montelukast available as 5 to 10 mg tablets is awaiting formal approval.

Methotrexate is of value in reducing the dose of steroids in severe chronic steroid-dependent asthma.

Box 21.2 presents grading of asthma and bronchodilator therapy in between attacks.

Box 21.2: Pharmacological management (long-term) of different grades of asthma

Mild intermittent (episodic) asthma: Oral or inhaled salbutamol or terbutaline as and when required

Mild persistent asthma: Inhaled short-acting beta₂ agonists plus inhaled steroids

Moderate persistent asthma

Severe persistent asthma: Inhalation steroids plus long-acting beta-agonist and/or slow release theophylline. Add on therapy with montelukast yields better control. Poor control is an indication for oral steroids (low dose alternate day prednisolone).

TUBERCULOSIS

Tuberculosis continues to be a common pediatric problem in the developing countries like India, particularly in the changed scenario following the onslaught of HIV/AIDS. Among the giant killers of children in these regions, it ranks high. Besides considerable mortality, this public health problem of a great magnitude causes much ill-health. According to an ICMR survey, the incidence of tuberculosis in India is 1 in 50. This figure is close to those reported from other developing countries such as Bangladesh, Pakistan, Malaysia, Indonesia, Sri Lanka, Nepal and United Arab Republic.

About 15 to 20% of pediatric beds in north India are occupied by infants and children suffering primarily from tuberculosis or tuberculosis in addition to another major entity like gross malnutrition. No other chronic infection of childhood comes anywhere close to this figure. Even in the pediatric outpatient departments, some 5 to 8% attendance is accounted by tuberculosis.

With the advent of HIV infection, a definite predisposing factor for tuberculosis, the incidence of tuberculosis is likely to show a remarkable rise in years ahead.

Etiopathogenesis

A child is infected by the bacilli from an open case of tuberculosis, usually an adult. The most common site is the lung though lymph nodes, tonsils, skin, intestine, etc. may be the other possible locations for the primary infection.

About 2 to 10 weeks (average 6 weeks) after this primary infection, many viable bacilli are transported to the regional lymph glands. There is an exudative reaction locally. This may result in caseation in the gland.

The original focus of infection develops an accumulation of polymorphs. This is followed by epithelioid cell formation. Finally, there results a typical tubercle formation with its surrounding layer of mononuclear leukocytes and occasional giant cells. This is what has been described as the *Ghon focus*. It is about a centimeter in diameter and, together with lymphatic drainage of the area and regional lymph glands, is termed the *primary complex* (Fig. 21.10). This focus usually shows slow healing with calcification and, sometimes, fibrosis. Primary complex is liable to "reactivation" following reinfection, especially about the time of puberty.

Towards the end of the incubation period, the individual's allergy may be manifested in the form of *fever, pleural reaction, erythema nodosum*—elevated ovoid patches, 1 to 3 cm in diameter, over the legs, uncommon in Indian subjects, primarily because of the dark skin—*phlyctenular conjunctivitis* and *positive tuberculin (Mantoux) test*.

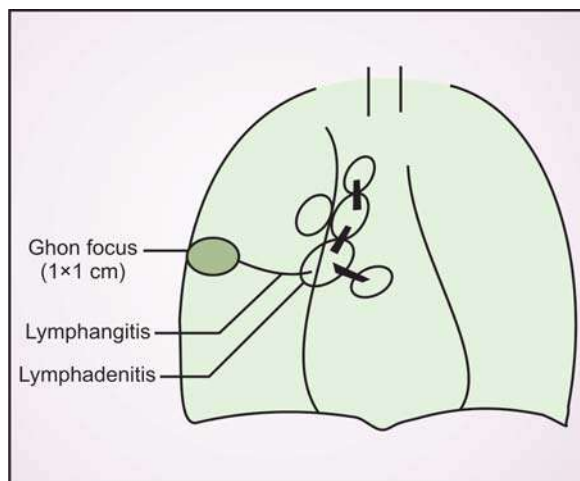

Fig. 21.10: "Primary complex" comprised by lymph nodes, lymphatics and Ghon focus

Congenital tuberculosis can occur from trans-placental infection, or the fetus inhaling the bacilli from liquor amnii as a result of the tuberculous focus in the placenta. It is characterized by enlargement and caseation of the glands at porta hepatis and disseminated tubercles throughout the liver. This comprises the primary complex. In addition, tubercles are scattered through the lungs, spleen and other viscera. Brain and meninges may be similarly involved.

Fate of Primary Complex

The unresolved primary complex may meet the following fate:

- Local spread may cause:
 - a. Progressive pulmonary lesions like extended parenchymal involvement and pleural effusion
 - b. Bronchial compression resulting in collapse or obstructive emphysema
 - c. Bronchial erosion resulting in spread of infection to various parts of the lung, the so-called *segmental or endobronchial tuberculosis*,
- Hematogenous spread occurs owing to the proximity of a minute lesion to the intima of a blood vessel or rupture of a caseous gland into a large vein. Blood dissemination may lead to extensive miliary mottling of the lung (miliary tuberculosis), involvement of brain (meningitis and tuberculoma), spleen, liver, glands, peritoneum (peritonitis), bones and joints, kidneys and skin.

Clinical Types and Salient Features

Clinical picture is variable. Of the various types, 41% are intrathoracic with a mortality of nearly 5% and 28% are CNS tuberculosis with as high a mortality as 30 to 50%. Other forms are less frequent.

Primary focus Usually there are no manifestations, especially in infants and young children. This has earned it the name *silent primary* which is, however, liable to get flared up by a subsequent attack of whooping cough or measles.

In older children, primary focus may cause vague symptoms like malaise, fatigue, anorexia, weight loss, failure to thrive and low-grade fever. This is generally overlooked.

A recent Mantoux conversion and routine X-ray examination of the chest often clinch the diagnosis.

Hilar lymphadenitis It is an important feature of primary complex. Cough, fever and weight loss are

its common symptoms. It is usually impossible to detect it by mere clinical examination. Radiology and positive tuberculin test often point to its presence. At times, paratracheal adenitis may produce marked widening of the superior mediastinum in a X-ray film (Fig. 21.11). It should be differentiated from shadow produced by thymus and glandular enlargement from a lymphoma or leukemias.

Segmental lesions Here, signs and symptoms will depend on the extent of progressive primary lesion and the type of segmental lesion produced as a result of bronchial compression or erosion. Radiologically, it is difficult to differentiate segmental lesion of tuberculosis from nontuberculous collapse/consolidation, or bronchiectasis. The presumed nontuberculous lung lesions that have failed to resolve despite adequate antibiotics over a sufficient length of time need reevaluation. This may be tuberculous.

Pleural effusion It is supposed to result from discharge of caseous material of a peripheral (subpleural) primary focus or enlarged regional lymph node. About 5 to 10% of children with pulmonary tuberculosis have pleural effusion. A vast majority of the patients are beyond 5 years of age.

Miliary tuberculosis It is the result of hematogenous dissemination and is characterized by extensive miliary mottling of lungs and involvement of spleen, liver and other tissues. CNS tuberculosis is a frequent accompaniment.

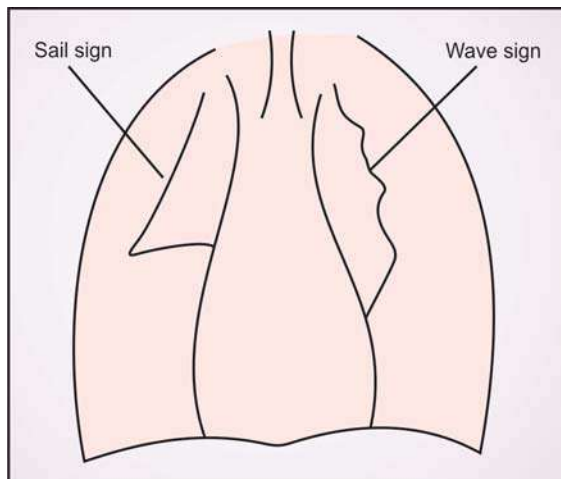

Fig. 21.11: Widened superior mediastinum. Sketch of the X-ray showing shadow produced by the enlarged thymus. Note the “sail” sign on the right and “wave” sign (due to indentation of ribs) on the left. This is an important differential diagnosis in shadow produced by hilar tuberculous adenitis

Its onset is usually insidious but may be sudden. High fever, malaise, night sweats, growth failure and anemia are the common manifestations. Cough is present in some cases. Hepatosplenomegaly is usually associated. Chest signs may be in the form of a few crepitations or may be absolutely absent. This happens in spite of marked toxemia.

X-ray chest is characteristic, demonstrating multiple minute dots which may blend. This has been described as *snow-storm appearance* (Fig. 21.12). The differential diagnosis is usually from staphylococcal pneumonia and tropical eosinophilia. Loeffler syndrome, histoplasmosis, whooping cough and hemosiderosis may also produce similar picture.

Tuberculin test is generally negative and is, therefore, not reliable in miliary tuberculosis. BCG test is often positive.

Almost half of the infants with miliary tuberculosis die.

CNS tuberculosis It is the most dangerous of all the forms of tuberculosis. As in case of miliary tuberculosis, its peak incidence occurs 6 months to 1 year after the primary infection. CNS tuberculosis is described in details in Chapter 23 (Pediatric Neurology).

Superficial tuberculous lymphadenitis It is quite a common problem in our country, constituting around 20% of cases of tuberculosis. Cervical glands are most frequently involved followed by axillary glands. Generalized adenitis is less frequent. To begin with, the

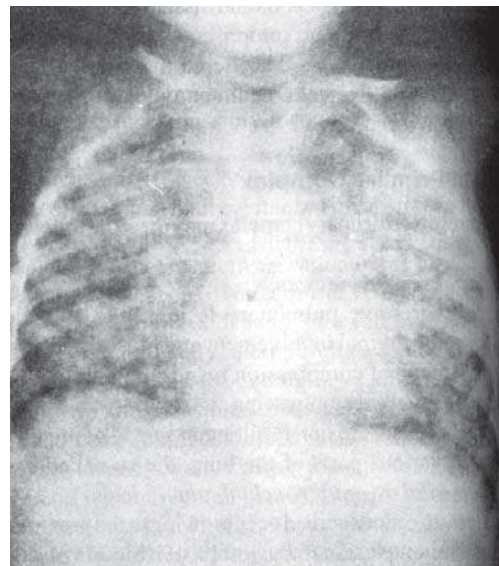

Fig. 21.12: Miliary tuberculosis. Note the snow-storm appearance as a result of multiple minute dots which tend to blend

glands are discrete and mobile but soon become matted and adherent to the overlying skin. The gland may caseate and discharge its necrotic material into the skin. The result is an exudative crusted skin lesion. This is called *scrofuloderma*.

In case of doubt regarding the tuberculous etiology of the superficial glands, fine needle aspiration cytology (FNAC) or a gland biopsy must be done.

Abdominal tuberculosis It is relatively uncommon. Three forms are usually described:

- i. Tuberculous mesenterica (glandular involvement)
- ii. Peritonitis which is of two types: (a) ascitic (b) plastic. *Ascitic abdominal tuberculosis* is characterized by massive ascites in a child who is otherwise emaciated. *Plastic abdominal tuberculosis* is characterized by chronic diarrhea, often alternating with constipation, chronic abdominal pain and growth failure.
- iii. Intestinal tuberculosis in which epithelial ulceration, resulting in chronic diarrhea, is the main presenting feature.

Abdominal tuberculosis is usually secondary to primary focus in the lungs or elsewhere in the body.

The diagnosis often presents difficulties. It is usually made on clinical grounds. The bacilli are infrequently demonstrable in ascitic fluid. Plain X-ray abdomen may reveal just calcified glands.

Skeletal tuberculosis Tuberculosis of bones and joints is almost always a late result of hematogenous spread from the primary complex in the lung. The common sites are spine (Figs 21.13 and 21.14), hip and knee joints. Tuberculosis of fingers and toes (*dactylitis*) also occurs. The manifestations of skeletal tuberculosis are generally local. Besides other measures, radiology of affected part is a "must" for the diagnosis.

Renal tuberculosis It is another late manifestation of hematogenous dissemination, taking 4 to 5 or even more years after the primary infection. Frequency of micturition, dysuria, sterile pyuria or painless hematuria may be the only manifestations. Obstructive uropathy due to involvement of renal pelvis and ureter may cause hydronephrosis.

Skin tuberculosis This may be in the form of:

- *Erythema nodosum* which occurs as a hypersensitivity response to the bacilli towards the end of the incubation period
 - Tuberculous ulcers* are characterized by undermined edges (Fig. 21.15).



Fig. 21.13: Psoas abscess. Radiologic survey revealed caries of the lumbar spine. BCG diagnostic test was strongly positive (25 x 25 mm) after 48 hours



Fig. 21.14: Caries of spine. Note the remarkable deformities of the dorsolumbar spine

- *Scrofuloderma* is the involvement of skin overlying caseous lymph glands. It consists of oval ulcers with undermined edge and flabby granulation tissue at the base. Extensive skin lesions may result.
- *Tuberculoides* are tiny papules with concave surface. They may be multiple and occasionally as large as a pea. They slowly heal. A whitish scar is usually left.
- *Lupus vulgaris* is the rarest among the tuberculous skin lesions seen in children. It consists of small pinhead papules that enlarge and blend to form



Fig. 21.15: Tuberculous ulcers with undermined edges. There was significant enlargement of regional lymph nodes. The cause appeared to be direct inoculation of tuberculous bacilli into skin

tubercles. The progression is slow but may cause disfigurement. Upper lip is the commonest site.

Chronic pulmonary tuberculosis A healed primary complex may get “reactivated” as a result of another infection or some precipitating factor like measles or whooping cough. This causes adult type of tuberculosis, the so-called *reinfection* or *chronic pulmonary tuberculosis* or *phthisis*. It shows maximum incidence in adolescent girls. Unlike pulmonary lesions of other forms of tuberculosis in pediatric practice, apical and infraclavicular sites are usual in this variety. Moreover, cavitation is more common and glandular involvement less remarkable.

Other forms of tuberculosis Tuberculosis of pericardium, ears and eyes—infact, almost any organ/part of the human body—occurs in areas where the disease has a high prevalence.

Major differences between childhood and adult tuberculosis are given in Table 21.12.

Diagnosis

Suspicion High index of suspicion is of considerable importance. Tuberculosis should be suspected in the presence of growth failure, malnutrition, pyrexia of unknown origin (PUO), prolonged cough, recurrent chest infections, painless lymphadenopathy, asthma, pleural effusion, pneumonia not responsive to

Table 21.12: “Childhood” vs “adult” tuberculosis

Childhood tuberculosis	Adult tuberculosis
Primary infection from an open case	Reactivation of healed focus or reinfection
Site of parenchymal lesion	Usually apical (primary focus) usually peripheral due to sluggish circulation
Healing by calcification in most cases	Fibrosis
Glandular element dominates	Uncommon
Segmental lesions common	Uncommon, cavitation frequent
Generally noninfective	Generally infective
Hematogenous dissemination common	Uncommon

antibiotics for pyogenic infections, and unsatisfactory recovery from illnesses like typhoid, whooping cough or measles.

In the wake of history of exposure to a known open case of tuberculosis in the family or the neighborhood, the child should be investigated for tuberculosis, especially if he is not already vaccinated with BCG.

Mantoux test 0.1 ml (5 units) of glycerinated purified protein derivative (PPD)* is injected intradermally over the anterior aspect of the forearm. The extent of induration (not erythema) is read after 48, 72 and 96 hours and classified as below:

Under 5 mm diameter—Negative reaction
 5 to 10 mm diameter—Doubtful reaction
 10 to 20 mm diameter—Positive reaction
 20 to 30 mm diameter—Moderate reaction
 30 to 40 mm diameter—Severe reaction

Interpretation Positive reaction reading, i.e. exceeding 10 mm, indicates the following:

- BCG already given to the child
- Infection with the virulent bacilli from a case of tuberculosis in the undermentioned situations:
 - a. Under 2 years of age
 - b. Under 6 years of age provided the child is exposed to a known case of tuberculosis
 - c. Recent conversion from negative to positive.

The stronger the reaction, more likely is the possibility of activity of tuberculosis. Thus, children

* Old tuberculin (OT) is best avoided in tropical areas. It deteriorates rapidly and has got to be used quickly after dilution

with Mantoux reading of over 20 mm have high chances of a demonstrable pulmonary lesion.

False-negative reaction Due to depressed sensitivity, an individual may show false-negative tuberculin reaction, despite the presence of tuberculosis, in the following situations:

- Poor technique
- Incubation period
- Advanced tuberculosis, e.g. miliary tuberculosis, tuberculous meningitis, etc.
- Convalescence from whooping cough or measles
- Steroid therapy.

BCG diagnostic test In recent years, there has been increasing documentation about the value of BCG vaccination as a diagnostic tool. It is believed to be far superior to tuberculin test. Its basis is “hypersensitivity”—the same as in case of Mantoux test.

The vaccination is done as described in Chapter 10. The appearance of a papule, more than 5 mm in diameter, during the first 24 to 72 hours, indicates a positive test (Fig. 21.16). The grading is as follows:

- 5 to 10 mm diameter: Mildly positive
- 10 to 20 mm diameter: Moderately positive
- Above 20 mm diameter: Strongly positive.

The various advantages of BCG as a diagnostic measure are:

- It is a very sensitive and reliable test.
- It is generally positive even in situations like miliary tuberculosis, tuberculous meningitis and severe malnutrition where Mantoux test is often false negative despite the presence of tuberculosis.
- With BCG the result is obtained in relatively shorter time, in a majority of the cases within 24 to 48 hours.
- Besides its diagnostic superiority, BCG has an added advantage of providing prophylaxis against serious forms of tuberculosis. It has thus economic significance as well.

Higher positivity of BCG test is attributed to greater amount of tuberculoproteins (20 to 50 TU against only 5 TU in Mantoux test).

Radiology Every child with suspected tuberculosis should have an X-ray chest. Radiologic appearances (hilar prominence, miliary tuberculosis, pleural effusion, calcification, segmental lesions, etc) are helpful in arriving at the diagnosis though these are seldom pathognomonic.

X-ray skull may reveal “silver-beaten” (also termed “copper-beaten) appearance, indicating raised



Fig. 21.16: Tuberculosis. Note the strongly positive tuberculin (Mantoux) and BCG diagnostic tests

intracranial tension, and/or calcification when tuberculoma is present. Depending on the affected part, such X-rays as those of bones, joints, abdomen, etc. may be required.

CT scan This may be of a great help in detecting tuberculoma, obstructive hydrocephalus, cerebral edema, infarction, basal exudates and fibrosis in CNS tuberculosis, as also in differential diagnosis of mediastinal and abdominal masses, skeletal and other local lesions, etc. It can also be of considerable help in follow-up. Pulmonary lesion missed by routine radiology of the lungs may be detected by CT scan.

Demonstration of bacilli Sputum, gastric lavage, laryngeal swab, pleural tap, cerebrospinal fluid (CSF), discharge from glands, etc. may be employed depending on the individual merits of a case, for smear (Ziehl-Neelsen method of staining), culture or guinea pig inoculation. The *fluorescent staining* with auramine 0 and examination under a good fluorescent microscope is superior to the conventional Ziehl-Neelsen method as far as positivity, ease of detection and speed are concerned.

Since culture of the slow-growing tuberculous bacilli (on conventional Lowenstein-Jensen egg medium or newer, the Dubos Oleic acid-agar medium) takes some 6 to 12 weeks for primary isolation, slide chamber or radiorespiratory techniques may be employed for evidence of growth in 8 to 10 days and 3 to 4 days, respectively.

Sensitive methods such as enzyme-linked immunosorbent assay (ELISA) or radioimmunoassay (RIA) may be employed to detect antibodies to antigens of bacilli in such specimens as CSF or urine.

Biochemistry Characteristic biochemical findings in CSF in TBM are elevation in proteins (slight to moderate) slight reduction in sugar, and marked reduction in chlorides in association with leukocytosis with predominance of lymphocytes.

Such body fluids as from joint cavity, pleural cavity and peritoneal cavity are characteristically straw-colored and exudates (proteins beyond 3 g%) with predominance of lymphocytes.

Fine needle aspiration cytology (FNAC) This simple diagnostic technique is now increasingly being employed and gives gratifying information.

Biopsy Histologic evidence of tuberculosis is often possible from liver biopsy, especially in disseminated (*hematogenous*) tuberculosis. Also, in doubtful superficial lymphadenopathy, a gland biopsy may be of much help. Biopsy may show a granuloma formation with giant cells and epithelioid cells and central caseation which is more characteristic of tuberculosis. Rarely, AFB may be demonstrated in the biopsied material. Some workers have found bone marrow studies of distinct help in the diagnosis of tuberculosis.

Polymerase-chain reaction (PCR), based on amplification of *M. tuberculosis*-specific DNA sequences in clinical samples, appears to be the most

specific, rapid and sensitive diagnostic test. However, it is quite expensive and needs to be restricted to difficult cases and research studies only.

Supporting investigation High ESR, choroid tubercles, etc.

The foregoing was the broad outline for diagnosis of tuberculosis. It should be remembered that not all these procedures are to be carried out in each and every patient. As for example, gland biopsy need not be done in a child suffering from pleural effusion with bilateral hilar prominence and strongly positive tuberculin test. Likewise, there is no need to do lumbar puncture in a child with primary complex but nothing at all indicative of CNS involvement. On the other hand, certain cases will require investigations not mentioned above. Suspected cases of abdominal tuberculosis will, for instance, need radiology of abdomen.

Antituberculous Treatment

Today, availability of modern antituberculous chemotherapy (Table 21.13) has considerably improved the prognosis of patients of tuberculosis. Institution of appropriate treatment in time in all types of tuberculosis, invariably cures the disease.

An ideal antituberculous drug need to possess three characters, namely:

1. Potent bactericidal activity against metabolically active bacilli,

Table 21.13: Salient details of commonly used antituberculous drugs

Drugs	Daily dose (mg/kg)	Route of administration	Side effects
Isoniazid	5 (preferably as a single dose)	Oral	Constipation, weight gain, euphoria, peripheral neuritis, convulsions, pellagra-like skin lesions, hepatotoxicity, very rarely bone marrow depression and toxic encephalopathy.
Streptomycin	20 to 50	Intramuscular	Deafness (eighth cranial nerve involvement), nephrotoxicity. It may cause severe and, at times, fatal reaction in HIV—positive subjects
Rifampicin	10 to 20	Oral	Rarely hepatotoxicity intermittent administration may be accompanied by thrombocytopenia and leukopenia, an influenza-like illness and respiratory syndrome.
Ethambutol	15 to 20	Oral	Anaphylactoid reactions, peripheral neuritis, hyperuricemia, retrobulbar neuritis
Pyrazinamide	30	Oral	Hepatotoxicity, gout
Ethionamide	15 to 20	Oral	Nausea, vomiting, pain abdomen
Ciprofloxacin	10	Oral	Hypersensitivity, arthralgia
Amikacin	7.5	Intravenous, Intramuscular	Nephrotoxicity

2. Sterilizing activity against semidormant persisting bacilli, and
3. Potential to prevent emergence of resistant organisms throughout the period of chemotherapy.

An agent that possesses all these characteristics to a sufficient degree is yet to be discovered. As of now, at least three antituberculous drugs must be given concomitantly, especially during the first two months, to safeguard against resistance. In all cases, therapy must be continued with at least two drugs over a period of several months.

By *bactericidal action* is meant the speed at which viable bacilli disappear from the sputum, etc.—during the first few days of chemotherapy. Isoniazid is the most potent bactericidal antituberculous drug followed by rifampicin and ethambutol. Streptomycin, pyrazinamide and thiacetazone have minimal or no bactericidal action.

Sterilizing action means elimination of sub-population bacilli that are unresponsive to other drugs, Rifampicin has the potential to kill the semidormant or intermittently active bacilli during the short period when they are susceptible to chemotherapeutic assault. Pyrazinamide is effective in zones of acute inflammation and against quiescent bacilli within macrophages. After the inflammatory process is over, it becomes less effective.

Inhibition of acquired resistance means suppression of proliferation of mutants resistant to other drugs. Isoniazid and rifampicin both are known for their sustained inhibitory effect. Pyrazinamide and thiacetazone are less effective. Thiacetazone is employed to inhibit the emergence of isoniazid-resistant strains in subjects on long-term regimens.

Indications for ATT

- All children with demonstrable active tuberculous lesions, e.g. progressive primary complex, pleural effusion, miliary tuberculosis, meningitis, etc.
- All children below 5 years of age having positive tuberculin/BCG test, provided BCG had not been already given to them.
- All children whose tuberculin/BCG test has recently converted positive, provided BCG had not been given to them a few months back.
- All unprotected children (BCG not given) who are exposed to open cases of tuberculosis.

Categorization of Antituberculous Drugs

Group I: First Line Drugs

These include isoniazid, rifampicin, streptomycin, pyrazinamine and ethambutol (Table 21.14). Majority of the patients respond well to these drugs.

Table 21.14: Indications for only isoniazid therapy

- Persistent lymphadenitis with or without suppuration and abscess formation, following BCG vaccination, provided that there is no other evidence of active disease.
- Positive tuberculin (Mantoux)/BCG test in a child under 5 years of age and who had not received BCG in the past
- A recent conversion of tuberculin (Mantoux) from negative to positive provided that BCG had not been administered a few months back
- Exposure of an unprotected child to an open case of tuberculosis.

Group II: Second Line Drugs

These include cycloserine, ethionamide, PAS, kanamycin and capreomycin. Their indications are (1) cases resistant to first-line drugs and (2) cases in whom first-line drugs cannot be employed because of adverse effects.

Group III: Reserve Drugs

These include quinolones (ciprofloxacin), amikacin, ampicillin and imipenem. These are indicated in drug-resistant cases.

Currently Recommended Antituberculous Regimens

Short-course chemotherapy (SCC), the standard current recommendation globally, is given in two phases, usually for 6 months:

1. *Intensive phase* This phase comprises administration of at least 3 drugs for 2 months to get rid of the bacterial load and to prevent emergence of resistant strains of *Myc tuberculosis*.
2. *Continuation phase* This phases comprises administration of at least 2 drugs to complete the course, usually for a period of 4 months.

World Health Organization (WHO) ATT Regimens

Regimens recommended by WHO on the basis of extensive field trials have produced cure rates

approaching 100% when drug-taking has been fully supervised. One of them should be selected for all newly confirmed cases of tuberculosis.

A 6 months regimen of daily isoniazid and rifampicin, supplemented by pyrazinamide for the first 2 months, is regarded as the most effective. These drugs should always be available for use in patients with tuberculous meningitis because they all penetrate freely into the cerebrospinal fluid when the meninges are inflamed. If resistance to any one of these three drugs is suspected, ethambutol or streptomycin should be added for the first 2 months. Streptomycin may still be in developing countries, where the patients are generally younger. Moreover, streptomycin helps to ensure compliance because its administration is supervised.

Where adequate facilities for fully supervised administration exist, a modified regimen in which the same drugs are taken three times weekly can be used.

An 8 months regimen comprising supervised administration of isoniazid, rifampicin, pyrazinamide and either ethambutol or streptomycin for 2 months, followed by 6 months self-administration of isoniazid and thioacetazone, is also effective and is used in some countries to reduce expenditure on drugs.

A 12 months regimen is much less effective and should be used only when the more potent drugs are not available and there is a problem of resistance.

Directly Observed Therapy (DOT)

Under the Revised National Tuberculosis Control Program (RNTCP), since 1992, India's strategy is to administer a short course ATT regimen with directly observed therapy (DOT) in an intensive phase followed by a supervised therapy in continuation phase till the subject is cured.

Indian Academy of Pediatrics (IAP) ATT Regimens

The IAP recommendations on ATT are given in Table 21.15.

The dosage recommendations are summarized in Table 21.16.

Comments

All the drugs should be administered in a single daily dose on an empty stomach.

Table 21.15: Indian Academy of Pediatrics (IAP) recommendations on treatment of childhood tuberculosis

Group 1 (Preventive Therapy)-6HR
Asymptomatic Mantoux positive < 3 years.
Asymptomatic Mantoux positive < 5 years with Grades III or IV malnutrition.
Mantoux +ve Recent converter/no signs (Healed lesion-Normal chest X-ray or calcification/fibrosis).
Children < 3 years with H/O +ve contact*
Children (5 years-Grades III or IV malnutrition with H/O +ve contact.
Group 2 2 HRZ/4 HR
Primary complex (Lungs)
Symptomatic Mantoux +ve < 3 years—without localization.
Symptomatic Mantoux +ve <5 years with grades III or IV malnutrition—without localization.
Isolated lymphadenitis.
Pleural effusion.
Group 3 2 HRZE/4 HR
Progressive pulmonary disease
Tubercular lymphadenitis-Multiple (In case of non-resolution of lesion, extend continuation phase by 3 months).
Group 4 2 HRZE/7 HR
Miliary/Disseminated disease
Cavitary disease/Bronchopneumonia
Osteoarticular disease
Abdominal, Pericardial, Genitourinary disease.
Group 5 2 HRZE/10 HRE
Neurotuberculosis

* as defined later

Table 21.16: Recommended doses

Drugs	Daily therapy (mg/kg)	Intermittent therapy (mg/kg)
Isoniazid	5+	15
Rifampicin	10	15
Pyrazinamide	25	30*
Ethambutol	20	30*
Streptomycin	20	30*
Prednisolone	1	—

+ Never < 5 mg/kg, to be rounded of to the closest higher dose.

* No studies conducted in children

The drugs are safe if used in the recommended dosage schedule.

Vitamin B₆ is not necessary in children taking INH.

Hepatotoxicity may be seen in vulnerable patients (malnutrition/disseminated disease).

Daily vs Intermittent Therapy

A daily treatment regimen is advised. Intermittent therapy regimen is not recommended as compliance

is generally poor and there is an increased risk of drug resistance. However, it may be considered only if compliance is assured.

Single Drug or Fixed-drug Combinations

Fixed-drug combination of isoniazid and rifampicin is acceptable. It is ideal to use pyrazinamide separately. Pharmacokinetic data regarding triple fixed dose combination in children is not adequate. Change in prescription from triple fixed dose combination to double fixed dose combination after first two months of treatment may be confusing to the patient.

Indications of Prednisolone

Neuro-tuberculosis, miliary tuberculosis, tuberculosis involving serous layers, endobronchial tuberculosis/segmental lesions, genitourinary tuberculosis/sinus formation. *Dose:* 1-2 mg/kg/day for 4-8 weeks (neurotuberculosis 8-12 weeks).

Baby Born to Mother with Tuberculosis (Diagnosed in 3rd Trimester or during Delivery)

Breastfeeding must be continued

BCG vaccine should be given at birth

If chest X-ray is normal, then **6 HR**

If chest X-ray is abnormal, then **2 HRZ/7 HR**

Congenital Tuberculosis: **2 HRZ/7 HR**

Hepatotoxicity

Clinical symptoms, hepatomegaly and jaundice merit laboratory tests and temporary stoppage of hepatotoxic drugs (HRZ). Routine monitoring of SGPT is not recommended. Suggested actions:

- Stop isoniazid, rifampicin and pyrazinamide.
- Start streptomycin and ethambutol. When SGPT returns to near normal (usually 2-4 weeks), restart INH at 5 mg/kg. Continue streptomycin and ethambutol. Restart rifampicin after 1 week. Stop streptomycin and ethambutol.
- Restart pyrazinamide after 1 week (if stoppage occurred in intensive phase of therapy).

Defaulter When treatment discontinued for > 1 week against medical advice, or lost to treatment Period of default > 1 month. *Suggested Actions*

- Default period between one week to one month : Continue the same phase of treatment for an additional one month.
- If default period is > 1 month, restart full treatment.

Drug Resistance

If a patient on prescribed treatment does not respond, check drug compliance, confirm diagnosis and assess for probable adult contact with multidrug resistant tuberculosis. Arrange for bacteriological study, if possible.

A child with cavitary disease or history of past treatment for tuberculosis is vulnerable.

In case of suspected drug resistance in absence of bacteriological proof, the suggested drug regimen is 2 SHRZE/1 HRZE/6 HRE.

In case of proved drug resistance, the suggested drug regimen is summarized in Table 21.17.

Table 21.17: Suggested drug regimen for proved drug resistance

	<i>Isoniazid</i>	<i>Rifampicin</i>	<i>Multidrug</i>
HIV -ve	12 RZE18-24 HZE	3 sensitive drugs for	2 yr after culture -ve
HIV +ve	18 RZE or 12 mo after culture -ve	18-24 HZE or 12 mo after culture -ve	3 sensitive drugs for 2 yr after culture -ve

Relapse

Reappearance of signs and symptoms of tuberculous disease within 2 years of cure after completion of specified therapy. Relapses are rare in children. Suggested drug regimen: Treat as suspected drug resistance in the absence of bacteriological proof.

Contact

Any child who lives in a house-hold with an adult taking antitubercular therapy or has taken antitubercular therapy in the past 2 years.

Indications of preventive therapy for contacts: < 3 yr / < 5 yr with Grades III and IV malnutrition/adolescents. Close surveillance is necessary for 5-12 yr old contacts. Suggested preventive therapy for contacts: 6 HR.

BCG Adenitis

If lymph node is small (< 1.5 cm), no treatment is required. Increasing size or fluctuant-Excision or **3-6 H**. Sinus formation: Excision.

Problems during ATT

Caution needs to be exercised while using isoniazid and rifampicin combination for a prolonged period

in view of the possibility of occurrence of hepatotoxicity.

Drug resistance is known to each and every antituberculous drug, the incidence being 10 to 20% on an average. It may be primary, meaning that the bacilli are already resistant, or secondary, meaning that bacilli are initially sensitive but later resistant mutants develop in the course of therapy. The causes may be:

- Monotherapy
- Irregular/inappropriate therapy.

Recommendations for Babies of Tuberculosis Mothers

Table 21.18 gives the protocol for infants of tuberculous mothers.

Table 21.18: Recommended protocol for babies born to tuberculous mothers

1. Continue exclusive breastfeeding
2. Mother should take ATT dose after feeding the baby. Next feed should be “top” so that minimal amount of ATT reaches the baby
3. Prophylactic therapy to baby with 3HR
4. Investigate with Mantoux test and X-ray at birth and then after 3 months
 - If both negative, give BCG vaccine
 - If one positive, continue 3HR
 - If both positive, give 2HRZ and 4HR

Newer Antituberculous Drugs

In view of increasing resistance to commonly used antituberculous drugs, it is vital to discover newer agents that have antituberculous activity against resistant bacilli. Currently, the some agents have emerged as promising antituberculous drugs for use in selected cases (Table 21.19).

Table 21.19: Newer antituberculous drugs

Quinolones Ciprofloxacin, ofloxacin, norfloxacin, pefloxacin, sparfloxacin, lomefloxacin, enoxacin
Rifampicin derivatives Rifabutin, rifapentine
Beta-lactams with Beta-lactamase Inhibitors Amoxicillin with clavulanic acid, ticarcillin with clavulanic acid, ampicillin with sulbactam
Aminoglycosides Kanamycin, amikacin, capreomycin
Macrolides Clarithromycin

Surgery

Indications of surgical intervention, greatly minimized over the years, are summarized in Table 21.20.

Table 21.20: Indications for surgery in tuberculosis

1. Lymphadenopathy
 - Biopsy
 - Abscess formation
 - Chronic sinus formation
2. Pulmonary tuberculosis
 - Bronchoscopy for diagnosis and management of certain selected cases of endobronchial tuberculosis
 - Bronchiectasis (secondary)
 - Collapse with repeated infections
 - Cavity formation with persistently positive sputum
 - Chronic encapsulated empyema
 - Chronic fibrosis
 - Constrictive pericarditis
3. Renal tuberculosis
 - Massive parenchymal destruction evidenced by nonfunctioning kidney with hypertension
 - Structural defects especially ureteric strictures
 - Persistent renal infection with resistant strains
4. Abdominal tuberculosis
 - Localized abscess
 - Localized hypertrophic bowel disease
 - Perforation of an ulcer
 - Gastrointestinal hemorrhage
 - Obstructive lesion, say cicatricial stenosis or mesenteric shortening
 - Peritoneoscopy for taking biopsy or for visualizing tubercles and strictures
5. CNS tuberculosis
 - Shunt procedure for obstructive hydrocephalus
 - Pott spine with compression symptoms and signs
6. Miscellaneous
 - Cold abscess
 - Ascites
 - Pleural effusion

It is advisable to administer isoniazid a few days before surgery and to continue it for one month following it, provided that the procedure is done under general anesthesia, in a child with positive tuberculin test.

Prevention

Prevention is accomplished by:

- Detection of cases of tuberculosis and their adequate treatment
- Chemoprophylaxis with isoniazid to high-risk infants and children
- Direct BCG vaccination
 - It is with the direct BCG vaccination to all children that tuberculosis can be controlled.
- Health education to the community concerning good sanitation and environment, avoiding

frequent spitting, never consuming unboiled milk and awareness of spread of tuberculosis. Integration of national and district tuberculosis control programs with general health measures is essential for this purpose. There is need for greater involvement of the community health workers who can be a part of the team at primary health centers and subcenters. This will, in a way, take the vaccination program to the people (including villagers) by the people *per se*.

RECURRENT RESPIRATORY INFECTION (Recurrent Chest Infection)

One of the common problems confronting a pediatrician is occurrence of frequent respiratory infection in infants and children during the first 2 to 3 years.

Various causes of recurrent respiratory infection are given in Table 21.21.

Table 21.21: Causes of recurrent respiratory infection

- **Anatomic Defects/Postnasal Drip** Deviated nasal septum, adenoids, sinusitis
- **Infections** Tuberculosis, asthmatic bronchitis
- **Allergic** Bronchial asthma, tropical eosinophilia, Loeffler syndrome
- **Genetic/Chromosomal** Down syndrome, cystic fibrosis, gargoylism
- **Aspiration** Hiatal hernia, tracheoesophageal fistula, achalasia
- **Immunodeficiency States** PEM
- **Mechanical** Foreign body, extrinsic compression of trachea or large bronchus by enlarged glands or heart
- **Miscellaneous** Congenital heart disease, especially left-to-right shunt.

THE CHILD WITH WHEEZY CHEST

The partial obstruction of the bronchi and the bronchioles (due to causes in the lumen, in the wall or outside the bronchi) may produce high-pitched whistling sounds often heard from a distance without the aid of the stethoscope. *Wheezing* is the term used for such sounds (Fig. 21.17). Differential diagnosis of wheezy chest is presented in Table 21.22.

Wheezing should not be confused with the following respiratory sounds:

- **Stridor:** Primarily an inspiratory sound secondary to upper airway obstruction (usually in larynx or trachea) of irregular quality produced by oropharyngeal obstruction.

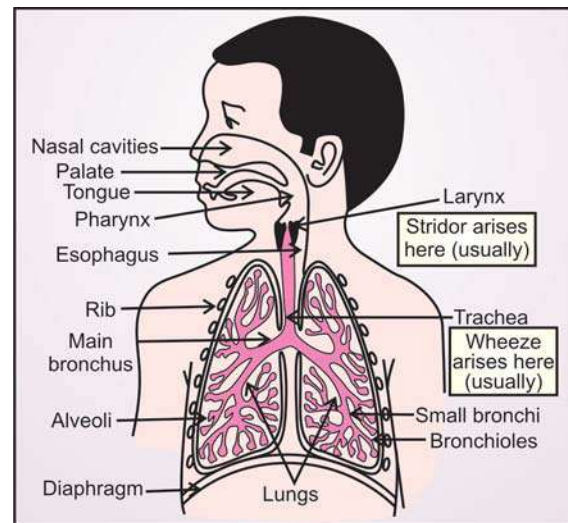

Fig. 21.17: Sites of development of stridor *vis-a-vis* wheeze

Table 21.22: Differential diagnosis of wheezy chest

1. Wheezy, spasmodic or asthmatic bronchitis*
2. Bronchial asthma
3. Bronchiolitis
4. Tropical eosinophilia
5. Loeffler syndrome and other hypereosinophilic states
6. Mediastinal glands tumors or aberrant vessels compressing the trachea or bronchi
7. Cystic fibrosis
8. Foreign body.
9. Pulmonary hemosiderosis
10. Aspiration syndromes: Prematurity, hiatal hernia, tracheoesophageal fistula, chaliasia of esophagus, epilepsy, kerosene, paraffin, baby powder
11. Congestive cardiac failure
12. Gastrointestinal reflux
13. Immunodeficiency states
14. Bronchiectasis, postpertussis, Kartagener syndrome

* Essentially asthma cases, needing follow-up

- **Grunting:** Expiratory sound produced by partial closure of glottis. Classically, it is encountered in hyaline membrane disease (HMD)
- **Snoring:** It is a low-pitched inspiratory sound

CYSTIC FIBROSIS

This genetic multisystem disorder of exocrine glands is now being increasingly diagnosed in the Indian subcontinent. The dominant manifestations are in relation to lungs secondary to the congestion and block of the passages with thick secretions (Box 21.3). In addition, the child suffers from recurrent/chronic

Box 21.3: Pulmonary/respiratory manifestations of cystic fibrosis (CF)**Symptoms**

- Cough
- Nasal obstruction and rhinorrhea
- Recurrent pneumonia
- Extensive bronchiolitis
- Wheezing
- Exercise intolerance
- Shortness of breath
- Hemoptysis
- Cor pulmonale
- Respiratory failure

Physical Findings

- Nasal polyp
- Increased anteroposterior diameter of chest
- Generalized hyper-resonance
- Scattered or localized coarse crepitations
- Digital clubbing
- Expiratory wheezes
- Cyanosis

Complications

- Atelectasis
- Pneumothorax
- Cor pulmonale

diarrhea with steatorrhea (secondary to pancreatic dysfunction with failure to thrive despite good appetite and intake. Diagnosis is established by sweat chloride >60 mEq/L though DNA studies should be considered the gold-standard now.

Also, see Chapter 24 (Pediatric Gastroenterology) for more details.

LEGIONELLOSIS*(Legionnaires' Disease, Pontiac Fever)*

This newly-recognized entity is caused by a Gram-negative organism, *Legionella pneumophila*, which is recovered from central air-conditioning systems, stream water, mud, etc. It infects through inhalation. Risk/predisposing factors include:

- Cancer or other disorder of immunosuppression
- Steroid therapy
- Renal homograft
- Diabetes mellitus therapy using diuretics.

Legionnaires' disease is a multisystem disorder with a relatively longer incubation period (2 to 10 days). Manifestations include high fever, chills, cough, chest pain (pneumonia is the hallmark of the condition), myalgia, headache, confusion and diarrhea. In

addition, liver and kidney dysfunction, convulsions, erythema nodosum, acute cerebellar ataxia, meningitis, etc. may occur.

Pontiac fever has a short incubation period (24 to 48 hours) and manifests with influenza-like illness minus pneumonia.

Diagnosis of legionellosis is by isolating the causative bacillus, or by serologic tests showing elevated antibody titer.

Whereas *pontiac fever* needs only symptomatic/supportive therapy, specific treatment is strongly indicated in case of *Legionnaires' disease*. This consists in administering intravenous erythromycin, 40 mg/kg/day, every 6 hourly. In the event of a poor response, a combination of erythromycin and rifampicin is the choice. Tetracyclines, cotrimoxazole, and ciprofloxacin are also effective.

Supportive therapy includes supplemental oxygen, assisted ventilation, correction of dyselectrolytemia, and management of renal failure and shock with vasoactive drugs.

Prevention is directed at removal of the implicated source, say in a cooling tower or an evaporative condenser, as also respiratory isolation of the patient.

DROWNING AND NEAR DROWNING

The term, *drowning*, refers to submersion in water leading to death within 24 hours. When the subject manages to survive after successful resuscitation for 24 hours, no matter whether he dies or survives later, the term, *near-drowning*, is used. If he dies later, the term *near-drowning with delayed death* is applied.

A vast majority of the drownings are accidental, e.g. mishaps in bathtubs, swimming pools, ponds, lakes, streams, flooded excavations, etc.

Aspiration, laryngospasm or breath-holding are responsible for most of the mortality. Whatever the operative factor, eventually hypoxemia is the common denominator. Hypoxemia is accompanied by varying degree of metabolic acidosis and transient hypercarbia.

Sea-water drowning causes hypertonic water to get into the alveoli whereas *fresh-water drowning* alters the surface tension properties of the "surfactant". Pulmonary insufficiency with intrapulmonary shunting and ventilation/perfusion mismatching are the features of both types of drowning. Pulmonary injury may be aggravated by concomitant aspiration of gastric contents.

In a large majority of the cases, tissue hypoxia may cause persistent metabolic acidosis. In fact, anoxia and metabolic acidosis rather than electrolyte imbalance contribute to most deaths.

Manifestations include tachycardia, bradycardia, cardiac arrest, pulmonary edema, hypothermia, arrhythmias including ventricular fibrillation, hypotension, and CNS dysfunction.

Treatment consists in providing immediate ventilation (mouth-to-mouth breathing, CPAP, intubation), oxygenation, and circulatory support (closed cardiac massage) diuretics, bronchodilators and IV soda bicarbonate may be employed depending on merits of the case. Only maintenance fluids are normally needed. There is no place for prophylactic use of antibiotics and/or steroids.

Serious neurologic sequelae may occur in some cases of near-drowning.

4

FURTHER READING

Articles/Chapters

- Bhaskar G, Lodha R, Kabra SK. Severe acute respiratory syndrome (SARS). *Indian J Pediatr* 2003;70:401-405.
- Anonymous. British guidelines on the management of asthma. *Thorax* 2003;58(Suppl):1-94.
- Indian Academy of Pediatrics. Consensus Statement of IAP Working Group: Status Report on Diagnosis of Childhood Tuberculosis. *Indian Pediatr* 2004;41:146-155.
- Jatana SK, Nair MNG, Lahiri K, Sarin NP: Polymerase-chain reaction in the diagnosis of tuberculosis. *Indian Pediatr* 2000;37:375.
- Kabra SK, Lodha R. Long-term management of asthma. *Indian J Pediatr* 2003;70:63-72.
- Lodha R, KMadhvi P, Cahndra U, Natchu M, Kabra SK. Persistent pneumonitis in children. *Indian Pediatr* 2003;40:967-970.
- Swaminathan S, Raghavan A, Datta M, et al. Computerized tomography detects primary lesion in children, with normal radiographs, diagnosed to have tuberculosis. *Indian Pediatr* 2005;42:258-261.
- US Centers for Disease Control and Prevention. Updated interim US case definition for severe acute respiratory syndrome (SARS). July 18, 2003. Available at: <http://www.cdc.gov/ncidod/sars/casedefinition.htm>.
- Vashishtha V. Severe acute respiratory syndrome (SARS). In: Gupte S (Ed). *Recent Advances in Pediatrics (Special Vol 14: Criticare Pediatrics)*. New Delhi: Jaypee 2004.
- World Health Organization. Severe acute respiratory syndrome (SARS). Available at: <http://www.who.int/csr/sars/en>. Accessed on Nov 4, 2003.

Book/Monograph

- Gupte S, Lahiri K. *Recent Advances in Pediatrics (Special Vol: Pediatric Pulmonology)*. New Delhi: Jaypee 2002.

CHAPTER



Pediatric Cardiology

PP Maiya, Karunakara BP, Suraj Gupte

EVALUATION OF A CARDIOVASCULAR CASE

An infant or a child with suspected cardiovascular disorder must be subjected to a good history and physical examination before taking a recourse to investigative evaluation. The significance of such an evaluation cannot be overemphasized.

Clinical Work-up

History should focus on cyanosis, squatting, fatigue, orthopnea, nocturnal dyspnea, feeding difficulty, sweating during feeding and chest pain. Attempt should be made to determine any history of presence of a generalized disorder affecting the heart as well. Any suggestion of a known congenital malformation syndrome, e.g. fetal-alcohol syndrome (ASD, VSD), VATER association (VSD, TOF, ASD, PDA). Down syndrome (endocardial cushion defects, VSD, ASD) needs to be taken notice of. In the family history, there may be suggestions of a generalized muscle disease (muscular dystrophy, dermatomyositis), prior congenital heart disease, or early coronary artery disease (familial hypercholesterolemia).

Physical examination should target at assessing the growth and development of the child at the very outset. Presence of cyanosis, clubbing, edema, chest deformity, engorgement of neck veins, tachypnea, and hepatomegaly needs to be specially observed. Pulse or cardiac rate and character of pulses provide valuable information. Blood pressure should preferably be recorded in the arms as well as in the legs. For this purpose, flush method is most feasible in restless infants.

Cardiac examination must in particular be very careful, noting the presence of a precordial bulge, substernal thrust, apical heave or a hyperdynamic precordium, thrills (both systolic and diastolic), aortic bruits, etc.

Auscultation of the precordium requires patience, first concentrating on the characteristics of the individual heart sounds and then on the murmurs. Later, attention should also be focused on clicks.

Murmurs should be described as to their timing, intensity, pitch, area of highest intensity and transmission. Whether a particular murmur is just functional (innocent with no significance) or has a pathological origin (congenital heart disease) must be decided. This may need additional investigations such as ECG, X-ray and/or echocardiography, etc. In certain cases, cardiac catheterization may be required, particularly as a part of preoperative evaluation.

Over 30% children may have a murmur without significant hemodynamic abnormalities. Typically, the so-called "innocent murmur" is heard in the age group 3 to 7 years, occurs during ejection, is musical and brief, is attenuated in the sitting position, and is intensified by pyrexia, excitement and exercise. As the child grows, such a murmur shows a tendency to be less well heard and may regress fully.

It is of help to apply the time-honored Nada's criteria for presence of heart disease in suspected cases (Table 22.1).

Also, see Chapter 1 (Pediatric History-taking and Clinical Examination) for additional details.

Table 22.1: Nada's criteria for presence of heart disease*Major*

- Systolic murmur. Grade 3 or more, always pansystolic
- Diastolic murmur
- Cyanosis (primarily central)
- Congestive cardiac failure

Minor

- Systolic murmur, less than Grade 3
- Abnormal second heart sound
- Abnormal ECG
- Abnormal X-ray
- Abnormal blood pressure

Note: Heart disease is indicated when one major or two minor criteria are present.

Investigative Work-up

4 *X-ray studies* are vital for cardiac size and shape pulmonary vascularity, pulmonary edema and accompanying lung and skeletal anomalies like dysplasias or abnormal number of ribs.

Cardiothoracic ratio (Fig. 22.1) is the ratio of maximum cardiac width and the maximum chest width in a midinspiration posteroanterior film with patient in upright position. A ratio of more than (0.5) 50% usually indicates cardiac enlargement. This ratio is more dependable in later childhood rather than in infancy. Even in later years, while interpreting this index, it needs to be ensured that thymic image or structural abnormalities of the thoracic cage such as pectus excavatum are not present.

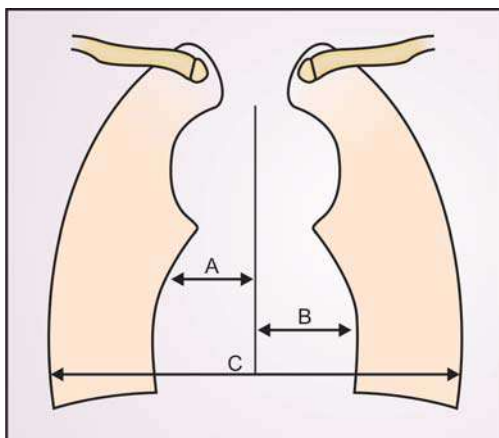
**Fig. 22.1:** Cardiothoracic ratio

$$= \frac{A+B}{C} = \text{up to } 0.5 \text{ (normal)}$$

In children a ratio 70.6 denotes cardiomegaly

Right border of the cardiac shadow consists of (from above downward) superior vena cava, ascending aorta and right atrium.

Left border of the cardiac shadow consists of (from above downward) aortic knob, main and left pulmonary arteries and left ventricle.

Enlargement of cardiac chambers or major arteries and veins is indicated by prominences of the areas of their outlines on the chest film.

Pulmonary vascularity is indicated by intrapulmonary shadows. Increased vascularity (overcirculation) is seen in left to right shunt whereas decreased vascularity (undercirculation) in right to left shunt.

Since esophagus lies in the proximity of great vessels, esophagogram and screening (fluoroscopy), using barium, is of value in delineating these structures in selected situations such as coarctation of aorta and vascular ring.

Electrocardiography (ECG) is a vital investigation for demonstrating anatomical and hemodynamic changes, mainly in QRS and T wave morphology. What is needed in pediatric practice is a 13-lead ECG, including lead V_3R or V_4R , the latter being a must for determining right ventricular hypertrophy (RVH).

Tall, narrow and spiked P waves (taller than 2.5 mm), resulting from right atrial hypertrophy, are seen in congenital pulmonary stenosis, Ebstein anomaly of tricuspid valve, tricuspid atresia, cor pulmonale, and sometimes thyrotoxicosis. Widened P waves, resulting from left atrial enlargement are encountered in ventricular septal defect (VSD), communications between aorta and pulmonary circulation, and severe mitral stenosis. Flat P wave is a feature of hyperkalemia.

RVH is denoted by (1) a qR pattern in right ventricular surface leads, (2) a positive T wave in leads V_{3-4R} through V_3 after first 48 hours of life, (3) a monophasic R wave in V_{3-4R} and/or V_1 , (4) rsR, in right precordial leads, (5) age-related voltage criteria in V_{3-4R} and V_1 (R), and/or $V_{6-7}(S)$, (6) significant right axis deviation, over 120 degrees, (7) a complete reversal of the normal adult precordial RS pattern, and (8) right atrial enlargement.

LVH is denoted by (1) depression of the ST segment and inversion of T waves and left precordial surface leads; a left ventricular strain pattern,

(2) increase in magnitude of initial forces to the right, meaning Q in left precordial leads, (3) voltage criteria in V3R and V1(S) and/or V6R.

QT interval, varying with the cardiac rate, is prolonged in subjects at risk of ventricular arrhythmias and sudden death, e.g. Jervell and Lange-Nielsen syndrome with hearing loss, Romano-Ward syndrome, etc.

ST segment elevation is seen in normal adolescents, generalized pericarditis, superficial epicardial involvement, etc. Its depression is a feature of digitalis therapy, myocardial damage as in anemia, carbon monoxide poisoning, endocardial fibroelastosis, aberrant origin of left coronary artery from pulmonary artery, mucopolysaccharidosis, glycogen storage disease and myocardial tumors.

T wave inversion is a feature of any carditis. In hyperkalemia, T wave is tent-shaped and of high voltage. Hypothyroidism, on the other hand, leads to flat or inverted T wave and generalized low voltage.

Complete bundle branch block is either congenital or a sequelae of open heart surgery. Left bundle branch block is either congenital or secondary to cardiomyopathy.

Echocardiography is a revolutionary tool in the evaluation of congenital and acquired cardiac disease. *M-mode echocardiography* aims at identifying the motion of intracardiac structures like opening and closing of valves and movement of septa, anatomy of valves, and presence of endocardial vegetations exceeding 2 to 3 mm. *Two-dimensional echocardiography* enables imaging the contracting heart by means of various views. It is a better technique, providing more realistic image of cardiac structures. *Doppler echocardiography* identifies flow instead of morphology in cardiac chambers and vascular chambers. Abnormalities in blood flow in congenital heart disease are identified by the directional quality of Doppler. Color Doppler permits better evaluation of intracardiac shunts and valvular insufficiency.

Transesophageal echocardiography is a yet more sensitive imaging technique that can identify very small lesions such as vegetations in endocarditis.

Magnetic resonance imaging (MRI) is of immense value in diagnosis and management of congenital heart disease. *Cine MRI* permits acquisition of images in many tomographic planes at different phases of

the cardiac cycle. *MR spectroscopy* allows demonstration of relative concentrations of high-energy metabolites (adenosine diphosphate, adenosine triphosphate, inorganic phosphate and phosphocreatine) within myocardium.

Radionuclide angiography is employed to identify and quantify shunts and analyze distribution of blood to each lung.

Gated blood pool scanning is employed to calculate the hemodynamic measurements, quantify valvular regurgitation and identify regional wall motion abnormalities.

Thallium imaging is employed to evaluate perfusion of cardiac muscle.

Cardiac catheterization, an important tool in the diagnosis of congenital heart disease, must only be limited to children, in whom the information obtained from echocardiography, including Doppler technique, and radionuclide studies, remains insufficient and the patient is a serious candidate for cardiac surgery. With this technique, different chambers of the heart are reached along with great vessels and veins. Blood samples are obtained for measuring oxygen saturation. Also, pressures are measured, and contrast and indicator materials injected if warranted.

A noteworthy practical difficulty with this technique is that it has got to be performed with the subject in a basal state. Else, calculations of hemodynamic measurements, say cardiac output, pulmonary and systemic resistance, and shunt ratios, are distorted. This prerequisite is often not workable in children.

Cardiac catheterization is not without risks. The potential complications include hypothermia, acidemia, excess blood loss, severe arrhythmias, cardiac perforations, and intramyocardial injection of contrast material by mistake.

Angiocardiography permits identification of specific cardiac abnormalities without interference from the superimposed shadows of normal chambers. It may be combination of photofluorography with a close-circuit television monitoring the fluoroscopic screen and allowing visualization of the cardiac silhouette and the catheter.

Interventional catheterization aims at offering nonsurgical treatment of certain cardiac lesions that until recently needed open heart surgery, e.g.

valvular pulmonary stenosis, aortic stenosis, PDA, secundum atrial septal defects, etc.

FETAL CIRCULATION

It is vital to bear in mind the following features which are characteristic of fetal circulation and differentiate it from neonatal circulation:

- Shunts, both intracardiac and extracardiac, are present.
- The two ventricles function in parallel instead of in series.
- The right ventricle pumps blood against a resistance which is higher than that of the left ventricle.
- The blood flow to the lungs is only a very minor proportion of right ventricular output.
- The lungs take oxygen from blood rather than supplying to it.
- The lungs continually secrete a fluid into the respiratory passages.
- The liver is the first organ to receive maternal substances like oxygen, glucose, and amino acids.
- The placenta is the principal site of gas exchange, excretion and acquisition of essential fetal chemicals.
- The placenta provides a low-resistance circuit.

Figure 22.2 depicts diagrammatic representation of fetal circulation, highlighting four sites of shunts, namely placenta, ductus venosus, foramen ovale and ductus arteriosus.

CIRCULATORY CHANGES AT BIRTH AND NEONATAL BLOOD CIRCULATION

At birth, with the cessation of placental circulation, major alterations in the circulation occur. These changes start immediately after birth and continue over a period of time thereafter. Clamping of the umbilical cord after the birth results in sudden increase in the systemic vascular resistance and consequent increase in the aortic blood pressure and left ventricular systemic pressure. The left ventricular diastolic pressure also tends to rise and increases the left atrial pressure. The sudden reduction in blood flow through the ductus venosus due to loss of placental circulation results in closure of ductus venosus. Exact mechanism by which the ductus venosus disappears is not known. The complete

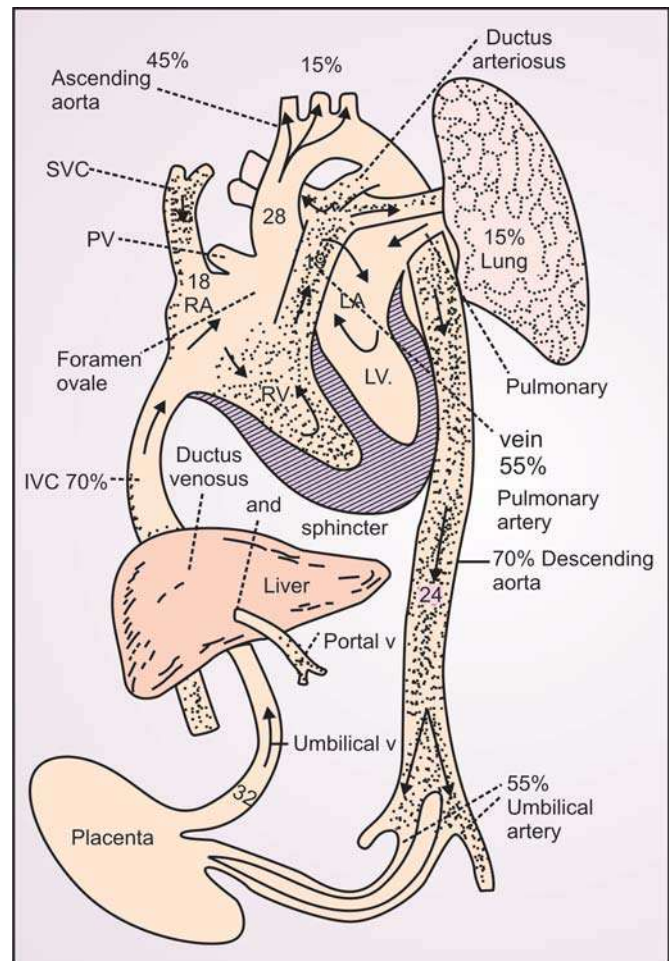

Fig. 22.2: Fetal circulation

cessation of blood flow through the ductus venosus occurs by 7th postnatal day of life. The loss of placental flow also results in decrease in volume of blood returning to the right atrium and consequent drop in the right atrial pressure. Increase in left atrial pressure results in left atrial pressure being higher than the right atrial pressure. This results in closure of foramen ovale. The approximation of septum primum with septum secundum results in closure of foramen ovale. The functional closure of foramen ovale occurs quickly. However the anatomical closure occurs over a period of months to year.

Sudden expansion of the lungs with the first few breathes results in fall in pulmonary vascular resistance, which in turn results in increased pulmonary blood flow.

The reversal of pressures in the major blood vessels; aorta and pulmonary trunk, with higher aortic

pressure leads to reversal of blood flow through the ductus arteriosus. Instead of flowing from pulmonary trunk to aorta, blood starts flowing in the reverse direction. This results in closure of ductus arteriosus. Though the exact mechanism is not known, the musculature of the ductus arteriosus has been found to be sensitive to change in oxygen saturation. Increased oxygen content in the blood causes constriction of the ductus musculature. In full term neonates, the ductus arteriosus closes within 10-21 days. In preterm babies, the functional patency may be precipitated by various problems in immediate postnatal period (Box 22.1).

The pulmonary vascular resistance and right ventricle pressure continues to decline over next few weeks and adult relationship of pressure and resistance in the pulmonary and systemic circulation is established in approximately two to three weeks. All these changes result in the establishment of postnatal circulation. The blood returning from different parts of the body through superior and inferior vena cava reaches right atrium, courses through the right ventricle and through pulmonary vessels to the lungs for oxygenation. Oxygenated blood reaches left atrium, then to left ventricle and pumped out by left ventricle through aorta and distributed to the body tissues.

Box 22.1: Postnatal closure of important communications of fetal circulation

Ductus venosus The sudden reduction in blood flow through the ductus venosus due to loss of placental circulation results in closure of ductus venosus. The complete cessation of blood flow through the ductus venosus occurs by 7th postnatal day of life.

Foramen ovale Increase in left atrial pressure higher than the right atrial pressure results in closure of foramen ovale. The functional closure occurs immediately and anatomical closure occur in months to year

Ductus arteriosus The reversal of blood flow through the ductus arteriosus from left to right side as a result of reversal of pressures in the major vessels results in closure of ductus arteriosus. In full term neonates, the ductus arteriosus closes within 10-21 days.

CONGESTIVE CARDIAC FAILURE (CCF)

Congestive cardiac failure is a common pediatric emergency. Since its etiology in infancy and childhood is at considerable variance with that of

adults, the diagnosis as well as therapeutic approach has certain special features.

By definition, *congestive cardiac failure (CCF)*, means failure on the part of the heart to maintain an output necessary for the needs of the body at rest or during stress following myocardial failure. Note the emphasis on “myocardial failure”. In constrictive pericarditis, the cause of peripheral circulatory congestion lies in definite mechanical obstruction and not in myocardium.

Etiology*

It varies with age of the patient (Table 22.2).

Clinical Features/Diagnosis

A. Infants

- Feeding difficulty
- Poor weight gain
- Irritability/excessive crying
- Excessive perspiration
- Wheezing
- Noisy labored breathing/tachypnea
- Hepatomegaly
- Cardiomegaly

Table 22.2: Causes of CCF according to age

Fetus	Severe anemia from fetomaternal transfusion or hemolysis, tachycardia (supraventricular or ventricular), complete heart block
Newborn	Transposition of great vessels, aortic atresia, coarctation of aorta, patent ductus arteriosus, pulmonary stenosis/atresia, hypoplastic left heart syndrome.
1 to 2 months	Transposition of great vessels, endocardial cushion defects, ventricular septal defect, patent ductus arteriosus, aortic stenosis, coarctation of aorta, anomalous pulmonary venous connection.
3 to 6 months	Endocardial fibroelastosis, transposition of great vessels, ventricular septal defect, coarctation of aorta.
6 to 12 months	Endocardial fibroelastosis, ventricular septal defect.
1 to 4 years	Carditis, anemia, nephrotic syndrome, acute nephritis, endocardial fibroelastosis, atrial or ventricular septal defect.
4 to 12 years and later	All foregoing causes plus rheumatic heart disease.

* Overloading of circulation, as in overhydration, or severe chest infection, may cause CCF at any age

- Tachycardia
- Gallop rhythm
- Edema, usually involving eyes, sacrum, legs and feet.

B. Children

- Dyspnea at rest (orthopnea) or on exertion
- Tachycardia
- Raised JVP
- Hepatomegaly
- Bilateral basal crepitations
- Edema
- Peripheral cyanosis
- Cardiomegaly
- Gallop rhythm.

Investigations

X-ray chest assists in:

- Assessing the cardiac size and pulmonary congestion
- Excluding pulmonary etiology
- Detecting congenital heart disease

ECG may show nonspecific T and ST segment changes, tall P wave and specific patterns of congenital and acquired heart diseases.

Echocardiography helps in assessing functional capacity of heart disease and diagnosis of infective endocarditis.

Other investigations include hemogram, serum electrolytes, blood gas analysis, renal function and blood culture.

Management

Goals

1. Reducing cardiac work
2. Increasing myocardial contractility
3. Reducing cardiac size for improving its performance
4. Treating underlying cause

1. Measures for Reducing Cardiac Work

- *Bed rest:* The best position is that of “propped up” at an angle of 45 degrees. Most infants will need bed rest for a short period. Children with rheumatic heart disease should be kept in bed as long as rheumatic activity is there.
- *Sedation:* Restlessness and anxiety should be controlled with morphia, pethidine, pheno-barbital, chloral hydrate, promethazine or diazepam.

- *Oxygen:* It is usually given by a nasal catheter but, if facilities are available, the most comfortable, and effective way of administering oxygen is plastic tent.
- *Antibiotics:* Antibiotics should be given to control the coexisting infection that could have precipitated the failure by increasing cardiac work.
- *Correction of anemia:* Blood transfusion (packed cells, 3-5 ml/kg), given carefully and slowly, leads to reduction in cardiac work. To prevent worsening of CCF, frusemide (0.5-1 ml/kg IV) may be given.
- *Vasodilators:* Such vasodilators as nitroglycerine and nitroprusside counter the existing vasoconstriction, thereby reducing work of the heart.

2. Measures for Increasing Cardiac Contractility by Inotropic Agents

1. *Digitalization:* Digitalis continues to be the corner-stone of management of CCF. Like most pediatric cardiologists, we prefer to use the time-honored preparation, *digoxin*. One ml of a popular brand provides 0.05 mg of the agent. Table 22.3 outlines the dose for different ages.

Table 22.3: Total oral digitalizing dose of digoxin

Age groups	24-hour doses (mg/kg)
Newborn	
Full-term	0.05
Premature	0.04
1 to 12 months	0.08
Beyond 1-3 year	0.06
> 3 year	0.04

- One-half of the total calculated dose should be given stat. Divide the remaining half in two doses. Each half should be given at 8 hours intervals. Maintenance dose will be 1/4th to 1/3rd of the total digitalizing dose. This is to be given either as a single dose or in two divided doses daily.

The above dosage is for oral administration of the drug. Parenteral dose should be about 2/3rd of the oral dose.

- Digoxin has been criticized on the ground that, being a catecholamine, it may further worsen the CCF which is known for high catecholamine level and myocardial dysfunction. Nevertheless, in practice, it has been found useful and is recommended in all grades of CCF. It improves

the cardiac output, thereby indirectly reducing the systemic impedance. This unloads the ventricles, reducing their work.

2. *New Inotropic Drugs*

- Catecholamine Group: Dopamine, Dobutamine
- Non-catecholamine Group: Amrinone, milrinone, xamoterol, flosequinon
- In practice, only dopamine and dobutamine are of proven value in pediatric CCF.

3. *Measures for Reducing Cardiac Size to Improve its Performance*

- *Digoxin*: By reducing the heart size, it improves the cardiac performance.
- *Diuretics*: Furosemide, in a dose of 1 to 3 mg/kg orally and 0.5 to 1.5 mg/kg parenterally, relieves edema, pulmonary congestion and liver enlargement and thus helps in controlling CCF. Spironolactone, a potassium-sparing mild diuretic serves as a valuable adjunct to furosemide in a dose of 1 to 4 mg/kg/day (O) in 2 divided doses.
- *Potassium*: Every patient of CCF who is digitalized and/or on diuretics should receive potassium supplements.
- *Diet*: A low salt diet is ideal though there may, at times, be practical difficulties in giving it to infants

4. *Measures for Correction of the Underlying Cause*

- Correction of the underlying cause should be seriously considered. This is particularly important when CCF is the result of or is precipitated/aggravated by anemia, nephrosis, overloading of circulation, severe chest infection, hypertension, fever, arrhythmias, pulmonary embolism, infective endocarditis, thyrotoxicosis, drug toxicity, etc. which can be taken care of without loss of much time. Surgically treatable causes like valvular lesions, obstructive lesions and shunts should be identified and adequately managed.

Refractory CCF Children with CCF that is refractory to the above-mentioned measures need

- Re-evaluation with a special search for unrecognized precipitating/underlying factor(s).
- Therapy with a vasodilator nitroprusside, intravenous inotropic (dopamine) or beta-blocker (propranolol) may be tried under strict hemodynamic monitoring (Table 22.4).

Table 22.4: Hemodynamic monitoring in CCF

- Serum electrolytes
- Blood urea
- Serum creatinine
- Arterial pressure
- Urinary output

Box 22.2: Stepwise-treatment of pediatric CCF

Step 1: Diuretics (furosemide) which improve the cardiac performance by reducing blood volume, peripheral vascular resistance and increasing the cardiac output

Step 2: Digoxin which improves cardiac contractility by its inotropic action, reduces cardiac work and decreases cardiac size.

Step 3: ACE inhibitors (captopril, enalapril) with withdrawal of potassium-sparing diuretics or supplementary potassium if given with other diuretics

Step 4: Vasodilators, preferably nitrates e.g. Isosorbide nitrate (O) or sodium nitroprusside (IV)

Step 5: Intermittent IV dopamine or dobutamine

Step 6: Beta-blockers (propranolol) or steroids if active myocarditis present

Step 7: Heart transplantation

Note: Steps 5-7 are usually needed in dilated cardiomyopathy

- Ultrafiltration or dialysis in the presence of renal shutdown.
- Cardiac transplantation with or without mechanical support may prove life-saving. Infrequently, following failure of all the measures (Box 22.2).

CONGENITAL HEART DISEASE

Incidence

Incidence of congenital heart disease in the west is around 10 in 1,000 live births. As yet, figures on incidence in India are not available.

About 2/3rd of the patients suffering from congenital heart disease have surgically correctable lesions with gratifying prognosis, provided that the surgical intervention is done in the very first year of life. This, together with the increasing information regarding its significant incidence, highlights that it is worthwhile to make an early diagnosis of the exact cardiac anomaly.

Etiology

Maternal Infections

Maternal rubella and other teratogenic viral infections, like herpes simplex, during the first 3 months of pregnancy, seem to have a definite bearing.

Maternal Medication

Drugs such as thalidomide consumed during pregnancy, may cause congenital heart disease. So does idiopathic hypercalcemia.

Heredity

The role of heredity is not clearly understood. The incidence is higher among siblings. Also siblings tend to suffer from the same disease. This author knows of a family with 3 siblings having ASD with bony defects, the so-called Holt-Oram syndrome. In another family, a brother and two sisters are suffering from VSD. In yet another case, a brother and a sister suffer from tetralogy of Fallot; the brother—a known case of Down syndrome—recently developed right-sided hemiplegia following an episode of severe gastroenteritis.

Genetic Factors

Genetic factors may predispose to occurrence of congenital heart disease. For instance, gargoylism, Marfan syndrome, Holt-Oram syndrome, Ehler-Danlos syndrome, etc.—all genetic disorders—are known to be accompanied by congenital heart lesions.

Chromosomal defects, say Down syndrome, trisomy 13-15, trisomy 16-18, Turner syndrome, etc., are usually accompanied by congenital heart disease (Table 22.5).

Environmental Factors

High altitude is said to exert considerable influence in causing congenital heart disease, especially in the susceptible hosts such as with hereditary predisposition. Both PDA and ASD are known to show higher incidences in population of high altitudes.

Genetic Counseling

The chances of second child with congenital heart disease in parents who already have a child with such malformation are 2 to 5% only. However, in parents with two siblings suffering from such a problem, chances of third child also suffering from a cardiac defect are very high—20 to 25%.

In the first situation, parents need to be encouraged if they intend to have another child. In the second situation, such an advice would not be in order.

Table 22.5: Cardiovascular anomalies in various syndromes/extracardiac lesions

Apert syndrome	VSD
Carpenter syndrome	PDA
CHARGE association (coloboma, heart disease, retardation, genital and ear anomalies)	VSD, ASD, PADA, TOF, ECD
CHILD (congenital hemidysplasia, ichthyosiform erythroderma, limb defects)	Miscellaneous
Congenital hypertrophic subaortic stenosis	VSD, PDA
Congenital rubella	PDA, peripheral pulmonic stenosis
Crouzon syndrome	PDA, COA
Cutis laxa	Pulmonary hypertension, PA Stenosis
deLange syndrome	VSD
DiGeorge sequence	Aortic arch anomalies, conotruncal anomalies
Down syndrome	VSD, ECD, ASD
Ellis-Van Crevald syndrome	Single atrium, ADS
Familial dwarfism and nevi	Cardiomyopathy
Familial elfin facies, mental retardation, infantile hypercalcemia	Supravalvular AS
FAVS (facio-auriculo-vertebral spectrum)	TOF, VSD
Fetal alcohol syndrome	ASD, VSD
Fetal hydantoin syndrome	VSD, ASD, COA, PDA
Fetal valproate syndrome	COA, hypoplastic left side of the heart, AS, PA, VSD
Holt-Oram syndrome	Familial ASD
Infants of diabetic mother	Hypertrophic cardiomyopathy, VSD, conotruncal anomalies
Jarvell-Lange-Nielsen syndrome	Prolonged QT
Kartagener syndrome	Dextrocardia
Laurence-Moon-Biedl syndrome	Variable, including TOF
Marfan syndrome dilatation,	Aortic or pulmonary artery MI
Noonan syndrome	PS, ASD, cardiomyopathy
Progeria	Accelerated atherosclerosis
Rubinstein-Taybi syndrome	PDA
Rubella syndrome	PDA, PS
Thrombocytopenia and absent radius (TAR)	ASD, TOF
Treacher Collins	VSD, PDA, ASD
Tuberous sclerosis	Myocardial rhabdomyoma
Ehler-Danlos syndrome	Arterial dilatation
Gargolism	Multivalvular and coronary artery disease
Morquio-Ulrich	Aortic incompetence
Osteogenesis imperfecta	Aortic incompetence
Trisomy 13-15	VSD, PDA, ASD
Trisomy 16-18	VSD, PDA, PS
Turner syndrome	COA, PS, AS
VATER association (vertebral, anal, tracheoesophageal, radial and renal anomalies)	VSD, TOF, ECD

Congenital heart disease is frequently associated with other congenital defects. As for instance, cataracts, skeletal anomalies and deafness are observed with increasing frequency in congenital heart disease. Down syndrome frequently has an associated cardiac anomaly such as atrioventricular canal, ventricular or atrial septal defect, etc. Also, more and more new combinations are being reported.

Classification

A. Group I: Acyanotic CHD (Left-to-Right Shunt)

- Ventricular septal defect (VSD)
- Atrial septal defect (ASD)
- Patent ductus arteriosus (PDA)

B. Group II: Cyanotic CHD (Right-to-Left Shunt)

I. Decreased pulmonary blood flow

- Tetralogy of Fallot
- Tricuspid atresia
- Transposition of great arteries with
 - VSD and PS
 - DORV with PS
 - Ebstein anomaly

II. Increased pulmonary blood flow

- Transposition of great arteries
- Persistent truncus arteriosus

C. Group III: Obstructive CHD

Right-sided

- Pulmonary stenosis (valvular)

Left-sided

- Coarctation of aorta
- Congenital aortic stenosis
- Vascular rings
- Anomalous origin of coronary arteries
- Congenital mitral stenosis
- Congenital mitral incompetence
- Dextrocardia.

Characteristic Features of Three Groups of CHD

Group I: Acyanotic (Left-to-Right Shunt)

- Frequent chest infections, including bronchopneumonia
- Tachypnea
- Absence of cyanosis
- Proneness to congestive cardiac failure (CCF), often manifested as increased sweating
- Precordial bulge due to cardiomegaly
- Hyperkinetic precordium on palpation
- Tricuspid or mitral delayed diastolic murmur
- Chest X-ray: Cardiomegaly, plethoric lung fields

Group II: Cyanotic (Right-to-Left Shunt)

- Cyanosis accompanied by polycythemia and clubbing
 1. Normal Pulmonary Arterial Pressure
 2. Diminished Pulmonary Arterial Pressure
Here, pulmonary blood flow too is diminished due to pulmonary stenosis
 3. Increased Pulmonary Arterial Pressure
 - (a) Increased pulmonary blood flow
 - Slight cyanosis
 - (b) Decreased pulmonary blood flow
 - Moderate to severe cyanosis
 - Irreversible pulmonary arterial hypertension
 - Poor prognosis

Group III: Obstructive

- Cyanosis
- Absence of frequent chest infections
- Absence of precordial bulge
- forcible or heaving cardiac impulse
- Thrill
- Ejection systolic murmur
- Absence of tricuspid and mitral delayed diastolic murmurs
- Delayed corresponding second sound.

VENTRICULAR SEPTAL DEFECT (VSD)

VSD is the most common acyanotic congenital heart disease. It accounts for 25% of overall congenital heart disease.

Classification

Classification of ventricular septal defect is given in Box 22.3.

Hemodynamics/Pathophysiology

The size of the left-to-right shunt depends on two determinants, namely the size of the VSD (largely) and the pulmonary vascular resistance (PVR) in relation to systemic vascular resistance.

In case of a *restrictive VSD* (under 0.5 cm²), higher pressure in the left ventricle is able to cause only a limited left-to-right shunt.

In case of a *nonrestrictive VSD* (large, usually over 1 cm²), pulmonary vascular resistance at birth is higher than normal. The magnitude of the shunt from left-to-right is, therefore, limited. However, with the

Box 22.3: Classification of VSD**I. Anatomic Classification**

1. Perimembranous (Subaortic, infracristal)
 - accounts for 75% of all VSDs
2. Muscular (anterior, midmuscular or apical)
 - accounts for 5-20% of all VSDs
3. Inlet (Inflow, canal VSD)
 - accounts for 5-8% of all VSDs
4. Outlet (subpulmonic)

II. Geodynamic Classification

1. Group 1: Small VSD, normal PVR, small L to R shunt
 - Asymptomatic
2. Group 2: Moderate VSD, variable PVR, significant L to R shunt
 - Some FTT and cardiomegaly
3. Group 3: Large VSD, moderately high PVR, significant L to R shunt
 - Symptomatic with CCF
4. Group 4: Large VSD, very high PVR, small or no L to R shunt, or R to L shunt
 - Symptomatic with cyanosis and PAH

III. ECHO-based Classification

1. Large: Defect = Diameter of aorta
2. Moderate: 1/3 to 2/3rd of diameter of aorta
3. Small: < 1/3rd of diameter of aorta
4. Pinhole: < 2 mm (detectable by color doppler only)

reduction in the resistance in the next few weeks, the shunt magnitude increases. When the shunt magnitude becomes quite large, VSD becomes symptomatic.

With passage of time, pulmonary vascular obstructive disease begins to develop. As soon as ratio of pulmonary to systemic vascular resistance approaches 1:1, the shunt becomes bidirectional. At this point, the child becomes cyanotic with disappearance of CCF signs. This state is called *Eisenmenger complex or syndrome*.

The enlargement of the chambers depends on the shunts which further depend on the ratio of the pulmonary to systemic blood flow.

When the ratio is under 1.75:1, the shunt is small, appreciable enlargement of the chambers does not occur and pulmonary vascular bed is by and large normal.

When, on the contrary, the ratio is above 2.5:1, the shunt is large, and left atrial and ventricular volume overload and right ventricular and pulmonary arterial hypertension occur. The large volume of pulmonary blood flow causes enlargement of the pulmonary artery trunk, left atrium and left ventricle.

Clinical Features

If septal defect is small, there may be no symptoms at all. The disease is detected incidentally during a routine clinical examination.

Large defect causes recurrent chest infections, congestive cardiac failure, failure to thrive, exertional dyspnea, etc.

In symptomatic patients, heart is moderately or greatly enlarged (usually biventricular). The characteristic murmur is loud pansystolic, heard maximal down the left sternal border (3rd, 4th and 5th intercostal spaces). It is usually accompanied by a thrill. A functional diastolic murmur, due to large blood flow across the mitral valve, may be present over apex.

In the presence of pulmonary hypertension, pulmonary second sound (P2), which is split, becomes accentuated. In such patients, a pulmonary diastolic murmur may also be found.

In older children, the additional findings may be in the form of wide pulse pressure and an early diastolic murmur at the base. These findings suggest development of aortic regurgitation as a complication of VSD (usually subpulmonic).

Diagnosis

X-ray chest is usually normal. Minimal cardiomegaly and slight increase in pulmonary vascularity may be noticed in all defects. In large VSD, it shows a large left-to-right shunt with enlarged heart (both ventricles and left atrium), enlarged pulmonary artery and plethoric lung fields (overvascularity) with or without hilar dance (Fig. 22.3).

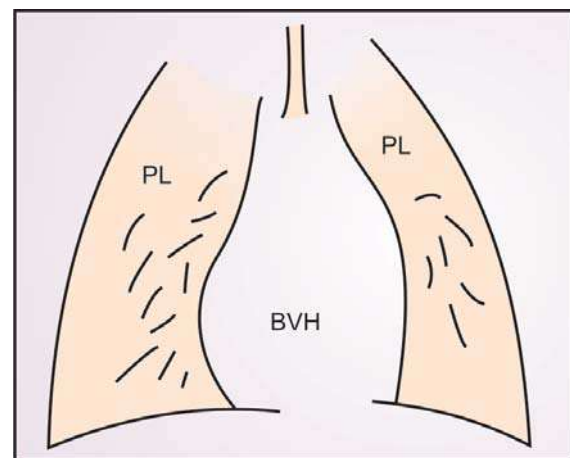

Fig. 22.3: Classical X-ray appearance of a large VSD
PL—Plethoric lung, BVH—Biventricular hypertrophy

ECG in small defects is usually normal but may show left ventricular hypertrophy. In large defects, ECG shows biventricular hypertrophy with notched or peaked P waves.

The 2-dimensional echocardiogram reveals volume overload of the left ventricle and left atrium, and the position and size of the septal defect (Fig. 22.4).

Cardiac catheterization and selective angiography are of much help in locating the site of the shunt.

Natural History/Course

An overwhelming proportion of small VSDs (60-90%) undergo spontaneous closure by 3 years. The moderate VSDs close in only 10% cases whereas large VSDs only infrequently close spontaneously. Nevertheless, reduction in size may occur often in small and moderate VSDs and occasionally in large VSDs.

Complications

- FTT
- Recurrent pneumonia
- Infective endocarditis
- Repeated episodes of CCF
- Pulmonary hypertension and its complications (Eisenmenger syndrome)
- Pulmonary stenosis (Gasul's VSD)
- Aortic regurgitation.

Treatment

General measures include attention to good nutrition with treatment of iron-deficiency anemia and other nutritional deficiency states.

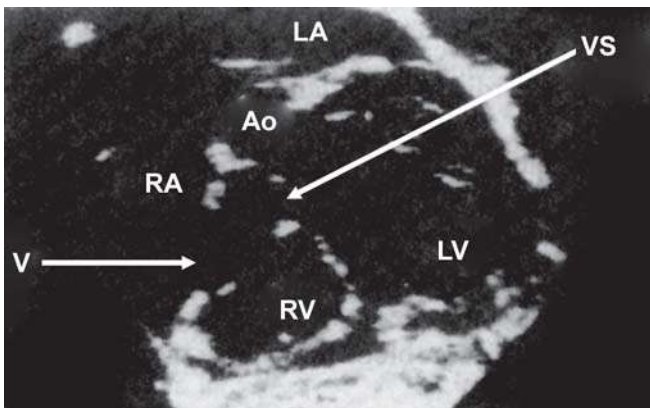

Fig. 22.4: Echocardiography (subcostal four-chamber view) of a ventricular septal defect (VSD)

CCF and recurrent chest infection are treated on usual lines.

Antibiotic prophylaxis for endocarditis is indicated.

Box 22.4 lists indications of corrective surgery in VSD.

Box 22.4: Indications of surgery in VSD

- Symptomatic VSD where medical therapy has failed to control symptoms, regardless of age
- Large VSD with PAH
- Supracristal VSD of any age
- VSD subject over 2 years of age with Qp: Qs ratio > 2:1

Successful corrective surgery can be performed in infants. The age of the patient is, therefore, not the deciding factor for surgery.

Complications of corrective surgery include:

1. Complete heart block
2. Bifascicular heart block
3. Residual/reopened VSD

Long-term prognosis following corrective surgery is excellent.

ATRIAL SEPTAL DEFECT (ASD)*

Patency of foramen ovale has no clinical significance.

Ostium secundum defect (high in atrial septum) may be as large as 2 cm. It occurs three times more in females than in males. Rarely, it is associated with mitral stenosis. The combination is named *Lutenbacher syndrome*.

In *Holt-Oram syndrome*, ASD is associated with skeletal deformities of the upper limb and hypoplasia of the clavicle (Fig. 22.5).

In *Ellis-van Creveld syndrome*, it exists in association with chondrodystrophic dwarfism and polydactyly, conical teeth, multiple frenulae and nail dysplasia.

Hemodynamics/Pathophysiology

The magnitude of the left-to-right shunt depends on size of the ASD, relative compliance of the two ventricles, and relative vascular resistance in the pulmonary and systemic circulations.

In a large ASD, pulmonary blood flow becomes 2 to 3 times the systemic flow. Yet, symptoms are absent or minimal in infants because the greater thickness and less resilience of muscular wall of the right ventricle limits the shunt. As the infant grows, the right

* ASD was the first congenital heart disease recognized in 1531 by Leonardo da Vinci

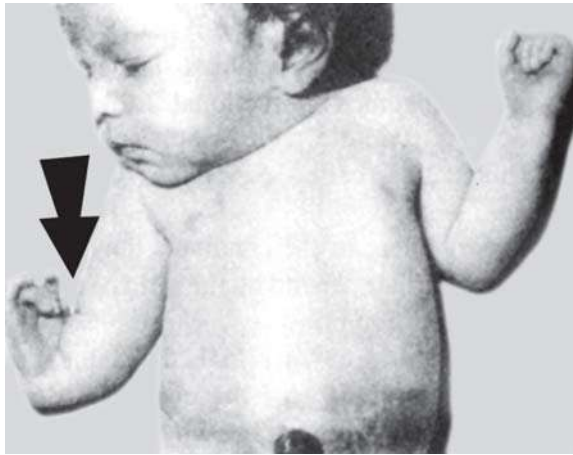

Fig. 22.5: Holt-Oram syndrome. Note phocomelia with hypoplasia of the thumb and clavicle on right side in a child with ASD (large ostium secundum defect)

4 ventricular wall becomes thin and more resilient, causing elevation in the shunt. Enlargement of the right atrium and ventricle and dilation of the pulmonary artery results from passage of large blood flow through the right heart. Nevertheless, pulmonary arterial pressure remains normal, pulmonary vascular resistance low and the left ventricle and aorta normal in size.

In adulthood, when pulmonary vascular resistance begins to increase, cyanosis may occasionally develop.

Clinical Features

ASD remains asymptomatic in most of the infants and young children. Older children may have recurrent chest infection, breathlessness and bulging of the chest due to enlargement of right ventricle. Another important feature is growth failure, which may be the only manifestation in some children.

The typical murmur is ejection systolic, soft, and best heard over upper left sternal border (usually the second space). It is preceded by a loud first sound and may be radiated to the apex and back. *P2 is widely split and fixed.*

Diagnosis

X-ray shows right atrial and ventricular enlargement, increased pulmonary vascularity, enlarged pulmonary artery and rather small left ventricle and aorta (Fig. 22.6).

ECG reveals RVH and right axis deviation. *Echocardiogram* shows evidence typical of right ventricle overload, say:

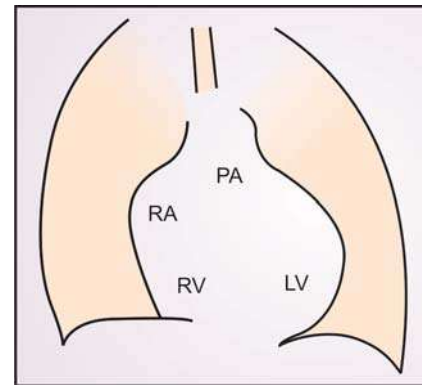

Fig. 22.6: Classical X-ray appearance of an ASD

- Increased ventricular end-diastolic dimension.
- Reversal of ventricular septal motion.
- Localization of the exact size and position of atrial defect by real-time 2-dimensional scans from apical position (Fig. 22.7).

Cardiac catheterization shows oxygen content of blood from right atrium to be far more than that from superior vena cava.

Complications

These are nearly on the same lines as in VSD. Infective endocarditis is infrequent.

Treatment

CCF and arrhythmias should be managed medically. Antibiotic prophylaxis during dental procedures is necessary.

The closure of defect by open-heart surgery gives gratifying results. It is best done in childhood.

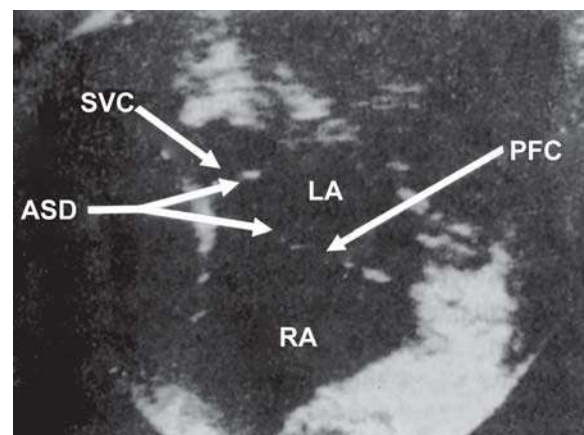

Fig. 22.7: Echocardiography (two-dimensional) of a sinus venosus atrial septal defect (ASD)

PATENT DUCTUS ARTERIOSUS (PDA)

PDA is unique in two ways. First, it occurs most often as an isolated defect which is unlike most other congenital cardiac anomalies. Secondly, it occurs twice as frequently in girls as in boys.

Hemodynamics/Pathophysiology

The magnitude of the shunt depends on the size of the ductus and the ratio of the pulmonary to systemic vascular resistance.

Since pressure gradient in aorta is dominant, blood flow is from aorta to pulmonary artery. In advanced cases, almost half or more of left ventricular output may be shunted through the ductus. In extreme degree of disease, pulmonary hypertension may occur.

Left untreated, such a patient may develop pulmonary vascular disease.

Runoff of blood into pulmonary artery during systole accounts for the high pulse pressure.

Clinical Features

Symptomatic cases have growth retardation, exertional dyspnea, left ventricular failure and CCF. Occasionally, precordial pain and hoarseness (due to recurrent laryngeal nerve involvement) may be present. Pulse pressure is wide. As a result, *water-hammer pulse* and prominent arterial *Corrigan pulsations* in the neck may be present. *Differential cyanosis*, in which left arm and both feet are involved, may be observed.

The classical murmur begins immediately after the first heart sound and reaches its peak at the end of systole. It continues during most of diastolic phase, gradually disappearing in the later part. This is what has been described as *machinery murmur*. It is harsh and may be localized to second left intercostal space or transmitted to left clavicle or lower down, i.e. left sternal border. It is usually accompanied by a thrill.

There may be *paradoxical splitting of P₂*.

Complications

- CCF
- Infective endocarditis
- Rarely, aneurysmal dilatation of pulmonary artery and/or ductus, calcification of ductus, thromboembolism, rheumatic heart disease and Eisenmenger syndrome.

Diagnosis

Radiology reveals biventricular enlargement, prominent aortic knob and pulmonary artery and plethoric lungs with hilar dance (Fig. 22.8).

ECG is usually normal but may show ventricular hypertrophy. Deep Q waves may be seen in left ventricular leads.

Echocardiogram is essentially normal in a small ductus. In case of a large ductus, there is an increase in left atrial and ventricular dimensions and decrease in isovolumic contraction time (Fig. 22.9).

Cardiac catheterization shows presence of oxygenated blood in the pulmonary artery and normal or raised pressure in right ventricle and pulmonary artery.

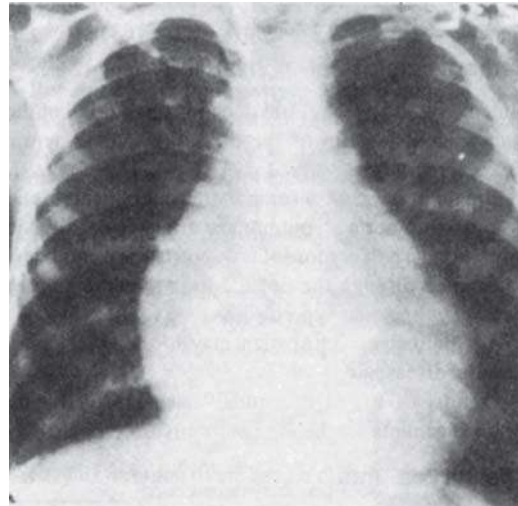

Fig. 22.8: X-ray chest showing cardiomegaly, prominent aortic arch and pulmonary artery in patent ductus arteriosus (PDA)

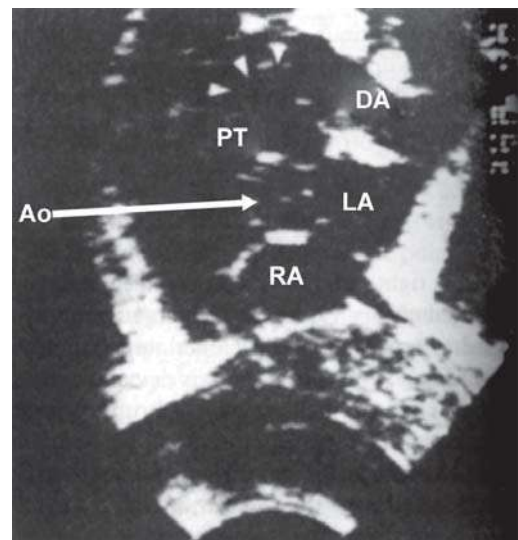

Fig. 22.9: Echocardiography (two-dimensional) in PDA

Treatment

Natural closure of PDA may occur in a small proportion of cases. If this is to happen, it *will* before the child has crossed his first birthday.

Asymptomatic PDA should be treated by ligation or division of the ductus, preferably between 3 to 10 years of age.

Symptomatic patients should be subjected to surgical correction irrespective of age and presence of pulmonary hypertension. Surgical closure is by ligation or by division and suture of ductus. The latter technique is considered better.

Medical management consists in tackling CCF and prevention and treatment of infective endarteritis.

The results of surgery are excellent. Recently, reports have appeared about the encouraging results obtained with the use of antiprostaglandin agents: aspirin, indomethacin and mefenamic acid (they inhibit prostaglandin E1 synthesis in infants with PDA).

TETRALOGY OF FALLOT (TOF)

It is the most common cyanotic congenital heart disease. Its essential components are: (i) Pulmonary stenosis (usually infundibular), (ii) Ventricular septal defect, (iii) Right ventricular hypertrophy and (iv) Dextroposition of the aorta.

Hemodynamics/Pathophysiology

Pulmonary stenosis and ventricular septal defects are the most vital abnormalities in TOF. The VSD is generally of the perimembraneous variety with extension into the outlet septum of the right ventricle, and is large and nonrestrictive, allowing equalization of pressure between the right and the left ventricle.

Pulmonary stenosis affects both the infundibulum and the pulmonary valve and artery. Infundibular stenosis is in part because of anterior deviation of the infundibular portion of the ventricular septum. Pulmonary stenosis is almost always present though it is seldom the only site of obstruction.

The spectrum of severity of disease in TOF is determined by the degree of obstruction of the right ventricle outflow tract.

When the right ventricle contracts, it meets much resistance at the pulmonary stenosis. The right-sided

blood is, therefore, shunted through the ventricular defect into the left ventricle and then on to aorta. The net result is persistent arterial unsaturation, polycythemia, cyanosis and poor pulmonary vascularity.

Occasionally, the degree of obstruction is small and the right-to-left shunt is minimal or absent. This mild form is termed *pink* or *acyanotic tetralogy of Fallot*.

Clinical Features

Manifestations of Fallot tetralogy usually become evident after the closure of the ductus arteriosus begins. Cyanosis of lips and nailbeds (*blue baby*) and dyspnea are the earliest presenting features. As the child grows, he feels comfortable while lying down or in *squatting position* only. *Anoxic, hypoxic or blue (hypercyanotic) spells* may occur due to cerebral anoxia. Such spells consist of dyspnea and cyanosis with or without unconsciousness. By the age of 2 years, the child usually develops some clubbing (Fig. 22.10).

CCF is unusual in infants and children suffering from Fallot's tetralogy.

Infants with mild outflow obstruction (pink or acyanotic TOF) usually develop cyanosis in the later part of first year (often 6 to 12 months of age). They may initially present with CCF due to a ventricular level left-to-right shunt.



Fig. 22.10: Gross clubbing in a girl with Fallot's tetralogy

Infants with severe outflow obstruction, develop cyanosis immediately in the neonatal period, usually in first few hours or days of life when the ductus arteriosus begins to close.

The typical murmur is loud short systolic, at left sternal border in third space. It is generally not accompanied by a thrill. This murmur is soft rather than harsh in very severe degree of the disease. P₂ is usually single.

Diagnosis

Blood studies show polycythemia and high hematocrit. X-ray chest (Figs 22.11 and 22.12) reveals oligemic lung fields (poorly vascularized lungs), a small boot-shaped heart (coeur en sabot) with the tip of the boot turned up above the diaphragm (because of right ventricular hypertrophy), and concavity of the pulmonary artery segment (small pulmonary conus). One in every 4 or 5 cases of Fallot tetralogy has right aortic arch.

ECG shows right axis deviation, RVH with tall and beaked P waves.

The 2-dimensional echocardiography shows the anterior-superior displacement of the the outflow ventricular septum, causing stenosis of the subpulmonic right ventricular outflow (Fig. 20.13).

Cardiac catheterization and selective angiocardiography are of great value to elucidate anatomic

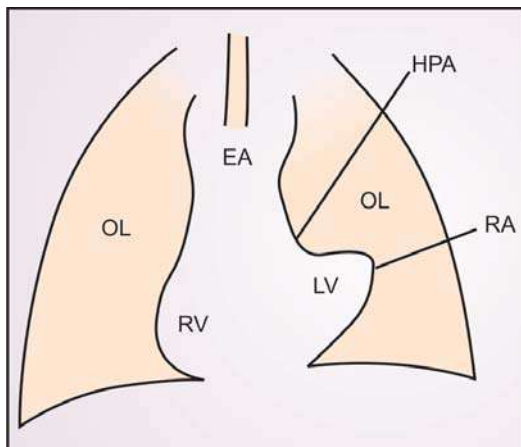

Fig. 22.11: Classical X-ray appearance of Fallot's tetralogy. Note the boot-shaped heart

- | | |
|----------------------------------|-------------------|
| EA-Enlarged aorta | RA-Raised apex |
| RV-Right ventricle | OL-Oligemic lung |
| HPA-Hypoplastic pulmonary artery | LV-Left ventricle |

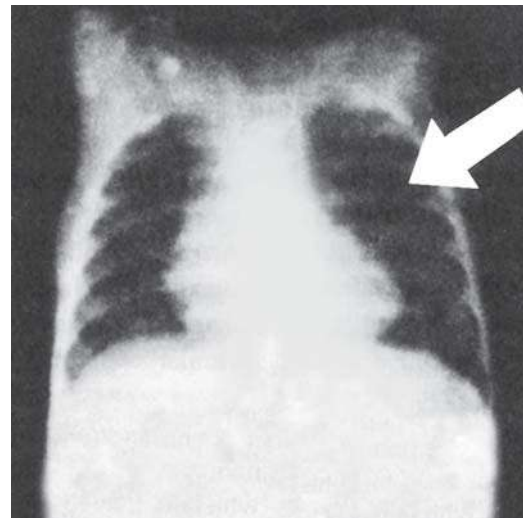

Fig. 22.12: Chest X-ray in Fallot's tetralogy. Note the boot-shaped heart and oligemic lung fields

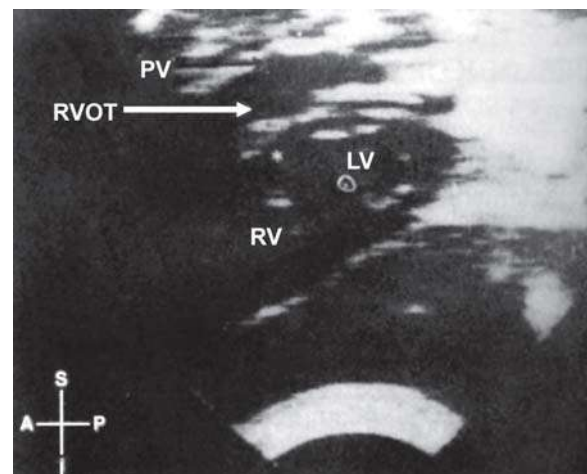

Fig. 22.13: Echocardiography (two-dimensional) in tetralogy of Fallot (TOF)

anomalies in tract and associated anterior ventricular septal defect in doubtful cases.

Cardiac catheterization shows remarkable fall in systolic pressure in the right ventricle as the catheter enters the pulmonary artery.

Ventriculography shows the anatomy of TOP at its best.

Aortography/coronary arteriography outlines the course of the coronary arteries.

Complications

- Cerebral thrombosis, especially in the presence of dehydration

- Brain abscess
- Bleeding diathesis
- Infective endocarditis
- Congestive cardiac failure, though infrequent, may occasionally occur in children with gross iron-deficiency anemia, or in young infants with pink or acyanotic TOF.

Associated Cardiovascular Anomalies

These include PDA, ASD, right aortic arch, anomalies of pulmonary arteries and aortic arch, persistence of a left superior vena cava, multiple VSDs, atrioventricular septal defects (often in Down syndrome), congenital absence of the pulmonary valve, marked aneurysmal dilatation of the main and branch pulmonary arteries, and absence of a branch pulmonary artery.

4

Treatment

General measures include correction of iron-deficiency anemia, and dehydration and an appropriate antibiotic for bacterial infection.

Management of spells Mild sedative like promethazine reduces the frequency of spells, provided it is given regularly. Oral propranolol therapy is of value in prevention. The dose is 0.5 to 1.0 mg/kg (O) every 6 hourly. Iron-deficiency anemia, if coexisting, should also be treated.

Nevertheless, the best approach is to refer the child for surgical treatment as soon as he starts having spells.

Selective treatment of acute hypercyanotic spell is outlined in Table 22.6.

Table 22.6: Selective treatment of hypercyanotic spells

1. Comfort the child and place in knee-chest position.
2. Administer humidified O₂ by face mask
3. Give morphine, 0.1-0.2 mg/kg. (IV)
4. Begin IV fluid replacement and volume expansion (if child is anemic, administer blood)
5. Treat acidosis with sodium bicarbonates
6. Administer propranolol, 0.1 to 0.2 mg/kg (IV)
7. Increase systemic vascular resistance by IV administration of vaso-pressors like methoxamine or phenylephrine. Titrate dose to increase systemic systolic blood pressure by 20%. In no case this step should be allowed to postpone surgical intervention
8. Operate to repair defect or to establish systemic-to-pulmonary artery anastomosis

Neonates with severe TOF are likely to deteriorate rapidly since the ductus arteriosus does not remain sufficiently patent to allow enough pulmonary blood flow. Pending surgery, they benefit considerably from prostaglandin E₁ (IV) which causes dilatation of the ductus and allows adequate pulmonary blood flow. It should be administered immediately on making diagnosis of cyanotic congenital heart disease in a dose of 0.05 to 0.20 mcg/kg/minute and continued through cardiac catheterization and surgery to briefly within postoperative period.

Surgery is possible if pulmonary artery is of adequate size. With surgery the patient lives a normal life. Without it, death usually occurs within 20 years.

I. Palliative Surgery

- *Modified Blalock-Taussig Operation* It consists in anastomosing the subclavian and the pulmonary arteries. This is the most popular systemic-to-pulmonary artery shunt today. It can be performed successfully even in a preterm neonate.
- *Potts' Operation* Here, a side-to-side anastomosis of pulmonary artery with aorta is created.
- *Waterson operation* It consists in constructing a shunt between the ascending aorta and the right pulmonary artery.

II. Total Correction

Direct-vision open heart surgery for repair of VSD and pulmonary stenosis later in childhood is the procedure of choice under ideal circumstances. Total corrections carries a mortality of 15%. Those who survive operation show complete disappearance of cyanosis and clubbing and improvement in growth and development. Risk of "sudden death" due to arrhythmias as also "exercise disability" remains high, however. Infrequently, a permanent complete heart block may occur following surgery. It is an indication for placement of a permanently implanted pacemaker.

FALLOT'S PHYSIOLOGY

This term is applied to the following five situations in which two of the major features of tetralogy of Fallot, i.e. a large ventricular septal defect and pulmonary stenosis together, occur in association with another major congenital cardiac defect:

1. Transposition of great arteries with ventricular septal defect and pulmonary stenosis.

2. Double-outlet right ventricle with pulmonary stenosis and a large subaortic ventricular septal defect.
3. Tricuspid atresia with decreased blood flow.
4. Single ventricle with pulmonary stenosis.
5. Corrected transposition of great arteries with ventricular septal defect and pulmonary stenosis.

Clinically, it is almost impossible to differentiate them from the tetralogy of Fallot since the symptoms and signs are by and large identical. ECG is of limited value (except in tricuspid atresia with decreased blood flow) but echocardiography has a vital role in the differential diagnosis (Table 22.7). Nevertheless, like TOP, all these conditions are surgically correctable.

TRICUSPID ATRESIA

The term denotes congenital absence of tricuspid valve, resulting in absence of any outlet from the right atrium to right ventricle. The entire systemic venous return, therefore, enters the left heart by means of the foramen ovale or an ASD.

Hemodynamics/Pathophysiology

Consequent to the entry of systemic blood through the foramen ovale or ASD into the left atrium from

right atrium, there occurs a complete mixing of the systemic venous and pulmonary venous bloods. From the left atrium, the mixed blood passes to the left ventricle. From the left ventricle, it crosses over to the right ventricle through a VSD. The size of this VSD and the presence and severity of pulmonary stenosis (which decreases the pulmonary blood flow) determine the degree of cyanosis with which most subjects present in early months.

Around 30% cases of tricuspid atresia may have associated transposition of the great arteries (TGA). The pulmonary blood flow in these cases is usually increased. Hence, they develop CCF early.

Clinical Features

In 90% cases, pulmonary blood flow is decreased. They have early onset of cyanosis and other features of TOF with the following exceptions:

1. Left ventricular apical impulse instead of right ventricular impulse
2. Holosystolic murmur along the LSB with a single second heart sound.
3. Prominent "a" waves in jugular venous pulse.
4. Hepatomegaly with "a" waves (presystolic pulsations).

4

Table 22.7: ECG and echocardiogram in Fallot's tetralogy and Fallot's physiology

Conditions	ECG changes	Echocardiographic changes
Tetralogy of Fallot	Right axis deviation, right ventricular hypertrophy, tall and beaked (occasionally bifid) and p wave	Diagnostic: extent of aortic over-riding of the septum, right ventricular outflow tract obstruction, size of proximal branch pulmonary arteries, side of aortic arch, status of PDA
Double outlet right ventricle with pulmonary stenosis and a large VSD	Right axis deviation, right ventricular hypertrophy	Both great vessels arising from right ventricle, mitral-aortic valve discontinuity
Tricuspid atresia with decreased blood flow	Diagnostic: Left axis deviation and LVH, QRS axis about -45°, p wave showing PAH and LAH	Only one ventricle and one A-V valve
Single ventricle with pulmonary stenosis	Left axis deviation with RVH or right axis deviation with LVH, monophasic or equiphasic QRS complex in all precordial leads	Absence or near absence of ventricular septum, whether single ventricle has right, left, or mixed morphology, rudimentary outflow chamber under a great vessel, bulbo-ventricular foramen
Corrected transposition of great arteries with ventricular septal defect and pulmonary stenosis	Right axis deviation, RVH, LVH, occasionally tall spiked p waves.	Inversion of ventricles

Diagnosis

In a large majority of the cases, *X-ray chest* shows pulmonary undercirculation (oligemia). Only in a small proportion (with TGA), overcirculation (plethora) is seen.

ECG is characteristic with left axis deviation and LVH with a mean QRS axis about -45° . P waves are consistent with both RVH and LVH.

The 2-dimensional echocardiogram shows replacement of the tricuspid valve by a fibromuscular membrane, a small right ventricle, VSD and a large left ventricle (Fig. 22.14).

Cardiac catheterization shows normal or slightly increased right atrial pressure with a prominent "a" wave.

Treatment

4 Medical treatment is on more or less the same lines as for TOF. An infusion of prostaglandin E1 is strongly recommended in severely cyanotic neonates while waiting for the surgical intervention to improve pulmonary blood flow.

Adequacy of the pulmonary flow determines the type of surgical intervention.

For most of the cases (decreased pulmonary flow), an aortopulmonary shunt procedure is required. The

preferred choice is *Blalock-Taussig shunt*. For the patients with increased pulmonary flow (TGA), pulmonary arterial banding is indicated.

Bidirectional Glenn shunt involves creation of an anastomosis between the superior vena cava and the pulmonary arteries. It is usually performed at the age of 4 to 12 months when the patient has outgrown the benefits of previous shunt.

Modified Fontan operation is the preferred approach at the ages of 1½ to 3 years. It involves caval-pulmonary isolation in which the inferior vena cava is anastomosed to the pulmonary arteries via a baffle that runs along the lateral wall of the right atrium.

The ASD/foramen ovale is also closed. Following this operation, the volume load is removed in toto from the left ventricle. The right-to-left shunt too is abolished. This operation may have postoperative complications in the form of pleural effusion in 5% cases, and late problems such as superior or inferior vena caval syndrome, vena caval/pulmonary artery thromboembolism, protein-losing enteropathy, supraventricular arrhythmias, and left ventricular dysfunction after or during adolescence.

EBSTEIN ANOMALY

This condition is characterized by diminished pulmonary blood flow as a result of downward displacement of the abnormal tricuspid valve into the right ventricle.

Hemodynamics/Pathophysiology

The abnormal tricuspid valve (all cusps except anterior) divides the right ventricle into two parts, an atrialized part that is continuous with the right atrium and a normal portion consisting of myocardial tissue. As a result, right atrium becomes huge. The tricuspid valve turns regurgitant. Also, there is variable magnitude of obstruction of the right ventricular outflow tract. The effective output from the right side of the heart is reduced and right ventricular function compromised. A right to left shunt through foramen ovale/ASD may allow passage of right atrial blood to the left atrium, causing cyanosis.

Clinical Features

Manifestations depend on magnitude of displacement of the tricuspid valve and right ventricular outflow tract obstruction.

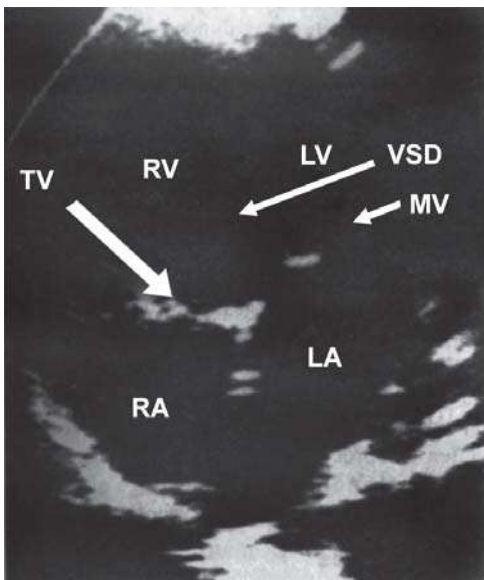

Fig. 22.14: Echocardiography (two-dimensional apical four chamber view) demonstrating VSD and tricuspid atresia (TA) along with transposition of great arteries (TGA)

These include fatigue, cyanosis clubbing, attacks of paroxysmal tachycardia, extrasystoles or other cardiac dysrhythmias.

The precordium is quiet but a holosystolic murmur (with a thrill) is heard over most of the anterior left side of the chest. There is also a superficial scratchy diastolic murmur at the left sternal border. This murmur resembles a pericardial friction rub.

The presentation of Ebstein anomaly in neonates is frequently with severe cyanosis, massive cardiomegaly with CCF and long systolic murmurs.

Diagnosis

ECG shows classical changes in the form of a right bundle branch block, P pulmonale, P mitrale and a normal or prolonged P-R interval. Wolf-Parkinson-White (WPW) pattern may sometimes be observed.

Echocardiography reveals the displaced tricuspid valve, a dilated right atrium, a right ventricular outflow tract obstruction, tricuspid regurgitation, and, in severe cases, immobile pulmonary valve.

Intracardiac electrocardiogram showing catheter is in the ventricle and the pressure recording showing right atrial type of pressure.

Cardiac catheterization and *selective angiocardiography* establish the existence of a large right atrium, an abnormal tricuspid valve and a right-to-left shunt.

X-ray chest may show normal to massive box-like cardiomegaly from enlargement of right atrium and ventricle.

Treatment

The surgical intervention in a neonate with severe disease aims at creating a functional tricuspid atresia by patch closure of the valve, atrial septectomy and placement of an aortopulmonary shunt (*Stranes procedure*). The tricuspid atresia so created can further be repaired with first Glenn operation and then modified Fontan operation.

In older children, treatment consists in controlling the supraventricular dysrhythmias followed later by repair of the valve or its replacement.

Prognosis

It is bad in case of neonates with overt signs and symptoms. In case of patients with mild anomaly, survival well into adulthood is usual.

EISENMENGER SYNDROME OR COMPLEX

The association of pulmonary hypertension with reversal of the shunt through VSD, PDA, etc. is called the *Eisenmenger syndrome or complex*.

Manifestations include cyanosis, dyspnea, fatigue and dysrhythmias. With progression of the disease, the subject may go into CCF and develop chest pain, syncope and hemoptysis.

Examination shows presence of cyanosis and a palpable pulmonary artery pulsation at left upper sternal border. Auscultation reveals a loud narrowly-split second heart sound and a soft ejection systolic murmur along left sternal border. A Graham steel murmur (blowing diastolic murmur as a result of incompetence of pulmonary valve) may be audible along left sternal border.

Radiology shows the heart size varying from normal to quite big, depending on the underlying condition.

ECG usually shows RVH but biventricular hypertrophy may occur. P wave may be tall and spiked.

Echocardiogram reveals a thick-walled right ventricle with, usually, increased dimensions of the chamber. Pre-ejection period/ejection time ratio is increased.

Cardiac catheterization reveals a bidirectional shunt at the site of defect.

It is a serious condition, carrying poor prognosis. *Treatment* is purely symptomatic. Frequent venesections with volume replacement may reduce polycythemia. Surgery is contraindicated.

TRANSPOSITION OF GREAT ARTERIES (TGA)

It is the most important cause of cyanosis right at birth or soon after it. Also, it is responsible for most of the mortality from cyanotic congenital heart disease in the first year of life.

TGA occurs predominantly in males (4 times more than in females). Incidence of diabetes in their grandparents is significantly high. Also, these babies are of relatively large birthweight though they gain poorly in subsequent months.

Transposition of great arteries is subdivided into complete type and physiologically corrected type. The complete type of TGA is further classified into TGA with VSD and TGA with intact ventricular septum. TGA with VSD is further subdivided into two groups based on the presence or absence of pulmonary

stenosis. TGA with VSD and pulmonary stenosis is similar to tetralogy of Fallot. In physiologically corrected TGA, the right atrium is connected to an inverted morphologically left ventricle, which is connected to the pulmonary artery. Left atrium is connected to the inverted morphological right ventricle connecting to the aorta.

Hemodynamics

In TGV, aorta arises from the right ventricle and the pulmonary artery from the left ventricle. The blood from right side of heart flows to aorta and the pulmonary venous blood is returned to lungs. Thus, with these two independent circuits, life can only be maintained postnatally if some communication between systemic and pulmonary circulation exists. Such a communication is usually provided by VSD, ASD, PDA or collateral circulation.

4

Clinical Features

Severe cyanosis (differential with legs being less cyanotic than the arms), appearing at or shortly after birth, constitutes the hallmark of TGV. Later, dyspnea, CCF and growth failure occur. Clubbing also develops in few months.

Heart is always enlarged. Murmurs are not of a classical pattern and are usually related to the type of coexisting communication.

Diagnosis

Radiology shows enlarged heart and grossly plethoric lung fields.

ECG reveals RVH, right axis deviation and often P-pulmonale.

Echocardiography (Fig. 22.15) confirms the diagnosis. It shows equal peak systolic pressure in both ventricles aorta and pulmonary artery.

Cardiac catheterization and *selective angiocardio-graphy* help in confirming the diagnosis.

Treatment

Medical treatment with IV prostaglandin E₁ (PG-E₁) digoxin, diuretics, iron, etc. should be given as and when indicated.

Of the various surgical procedures, *Beffe's operation* seems to offer the best results. It consists in partial redirection of venous blood, i.e. vena caval

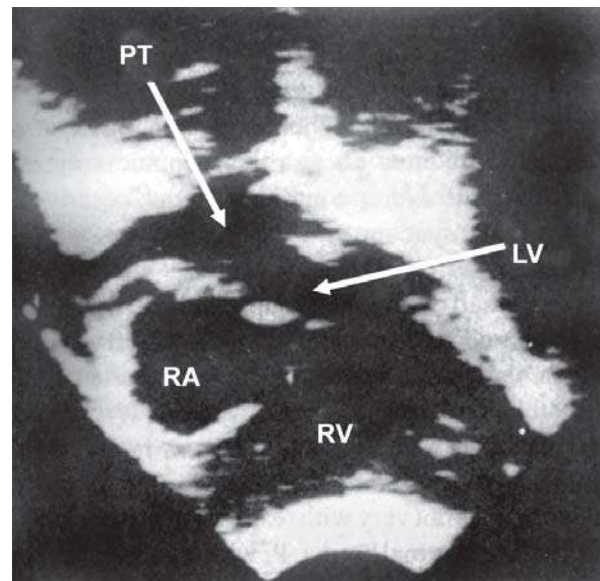

Fig. 22.15: Echocardiography (two-dimensional) in TGA

anastomosis to the left atrium and pulmonary veins to the right atrium.

The complete correction is still in experimental stage.

TOTAL ANOMALOUS PULMONARY VENOUS RETURN (TAPVR)

In this uncommon cyanotic congenital heart disease, pulmonary veins fail to join left atrium and, instead, are connected anomalously so that total pulmonary venous blood reaches right atrium. It may be of supracardiac, cardiac, infracardiac or mixed type. Infracardiac TAPVR is always obstructive. Nonobstructive type is more frequent. In both types, there is a mixing of oxygenated and deoxygenated blood before or at the level of the right atrium.

Manifestations include 3 patterns. First: Severe tachypnea, cyanosis and moribund state in neonates with severe obstruction. Second: CCF (without cyanosis) early in life with gallop rhythm and murmurs along the left sternal border, pulmonary hypertension when obstruction is only slight or moderate. Third: Absent or mild cyanosis in infancy; there is absolute mixing of pulmonary venous blood with a large left to right shunt.

X-ray chest is pathognomonic with figure of 8 or snowman configuration with a characteristic supracardiac shadow (Fig. 22.16).

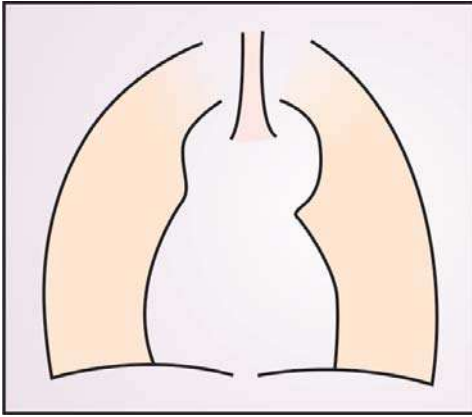

Fig. 22.16: Diagrammatic representation of radiologic appearance in total anomalous pulmonary venous return. Note the Snowman or figure of 8 configuration

ECG shows RAD and RVH. In case of severe obstruction, P-pulmonale may be seen.

Echocardiography shows a venous channel in abdomen and flow away from heart is pathognomonic of TAPVR.

Treatment is surgical correction preceded by stabilization with prostaglandin E_1 (PGE_1) so that ductus venosus and ductus arteriosus are dilated.

Without treatment, most subjects with TAPVR succumb to CCF.

HYPOPLASTIC LEFT HEART SYNDROME

The syndrome refers to the presence of obstructive lesions (vascular or valvular) on the left side of the heart, leading to hypoplasia of the left ventricle. It is by no means uncommon.

Hemodynamics

In all of the lesions that make this syndrome, namely mitral atresia, aortic atresia or stenosis, gross obstruction to either filling or emptying of the left ventricle during intrauterine life leads to a very small amount of blood in the left ventricle. As a result, the left ventricle becomes hypo-plastic. After birth, two factors (obstructive lesions and hypoplastic left ventricle) join hands in impairing the circulation, resulting in congestive cardiac failure, usually within some days but always before the age of 3 months.

Clinical Features

Congestive cardiac failure develops fairly early, particularly in subjects with aortic atresia in whom it may

occur as early as in the first week of life. In aortic involvement, cyanosis may be differential but it is usually generalized in most cases of this syndrome.

Murmurs, if present, are usually nonspecific and not diagnostic.

Diagnosis

Right at birth, *X-ray chest* is normal but soon it reveals progressive cardiomegaly with plethoric lung fields.

ECG changes include right axis deviation, right atrial hypertrophy, right ventricular hypertrophy with relative paucity of left ventricular forces and absence of q wave in V_6 .

Echocardiography shows a diminutive aorta and left ventricle with a poorly defined mitral valve in the presence of a normal and easily definable tricuspid valve. These findings are diagnostic.

Treatment and Prognosis

Currently, no effective treatment is available. CCF is the rule. Death occurs very early in aortic involvement and relatively late in mitral atresia. A few patients have lived a decade or so.

AORTIC STENOSIS

Depending on the site of obstruction to the outflow of blood from the left ventricle in relation to the aortic valve, congenital aortic stenosis may be divided into: valvular, subvalvular (subaortic), and supra-valvular. Valvular stenosis accounts for 75% of the cases of aortic stenosis. Subvalvular stenosis is of three types: discrete membranous, fibromuscular and idiopathic hypertrophic.

Hemodynamics

Obstruction to the left ventricular outflow as a result of aortic stenosis increases the load of left ventricle. This is accomplished by raising the systolic pressure inside it and by its hypertrophy. An aortic valve of less than 0.5 sq cm/sq m body surface area or a pressure gradient of more than 70 mmHg across aortic valve is regarded as severe obstruction.

Clinical Features

Most patients have no manifestations, except easy fatigability and exercise intolerance and, occasionally, dizziness and syncope.

In *valvular aortic stenosis*, pulses are normal but may be small with a slow upstroke, if the pressure gradient exceeds 80 mm Hg. Apex shows left ventricular thrust and a systolic thrill at right base, suprasternal notch and both carotid arteries (in mild disease only right carotid artery) may be found.

Auscultatory findings include a prominent ejection click that does not vary with respiration at the aortic area and lower left sternal border, P₂ which is physiologically split and a grade 3 to 4/6 rough, medium to high-pitched ejection systolic murmur which is best heard at the first and second spaces and is radiated to suprasternal notch and the carotids, as also down the left sternal border and the apex.

In *discrete membranous subvalvular aortic stenosis*, the clinical findings are essentially the same but there is no ejection click and a diastolic murmur of aortic regurgitation is usually present after the age of 5 years.

Fibromuscular subvalvular aortic stenosis is clinically almost impossible to differentiate from the discrete membranous type.

Idiopathic hypertrophic aortic stenosis (IHAS) too does not show any ejection click. The ejection systolic murmur (grades 2 to 3/6) is heard over the left sternal border and the apex. A murmur of mitral regurgitation usually accompanies it.

In *supravalvular aortic stenosis*, the patient has characteristic "elfin facies" with prominent forehead, epicanthal fold, depressed bridge of nose, overhanging lip, deformity of teeth and strabismus, and mental retardation. It may coexist with metabolic disorders like idiopathic hypercalcemia and hypervitaminosis D. The condition is often familial.

The cardiac findings include the thrill and, murmur which are best found in the suprasternal notch and along the carotids. The pulse and systolic pressure in the right arm is higher than in left arm.

Diagnosis

X-ray chest shows somewhat prominent left ventricle though heart size is usually within normal limits. Dilatation of aorta suggests valvular and, sometimes, discrete membranous subvalvular stenosis.

ECG is normal in mild disease. In severe obstruction, the changes include left ventricular hypertrophy and strain which may be progressive

and left ventricular strain which warns that operative intervention is warranted.

Echocardiography is of value in the diagnosis and follow-up of IHAS and other types of the disease.

Serial catheterization may well be the only dependable guide to the progression of the disease. *Cineangiography* assists in demonstrating the exact site of the stenotic lesion.

Treatment

The patient should have close follow-up. He should be discouraged from overexertion, i.e. competitive sports, athletics and strenuous exercise.

Surgery in the form of aortic valvotomy and aortic valve replacement is indicated in the presence of significant manifestations or a large resting gradient of 60 to 80 mm Hg.

Unfortunately, surgery in the form of valvotomy may be complicated by aortic regurgitation which is worse than the stenosis. The patient who gets valve replacement has got to be on anticoagulants. Secondly, neither the prosthetic nor the homograft valve lasts indefinitely.

The results of surgery in discrete membranous subvalvular aortic stenosis are better than in valvular.

COARCTATION OF AORTA SYNDROME

The coarctation or "constriction" may be distal to the ligamentum or ductus arteriosus or the subclavian artery ("postductal"), or proximal to them (preductal). The constriction is in the shape of a sharp indentation involving the anterior, lateral and a posterior wall of the aorta. The aorta immediately distal to the coarctation is often dilated.

The term, *coarctation of aorta syndrome*, is now regarded as a better nomenclature since many symptomatic patients, particularly infants, are likely to have such accompaniments as VSD, PDA, tubular hypoplasia of the aortic isthmus and bicuspid aortic valve.

The disease occurs thrice more frequently in males than in females. It is a common association in Turner syndrome.

Hemodynamics

In the so-called "preductal (infantile) type", the very high load on the left ventricle causes elevation in both

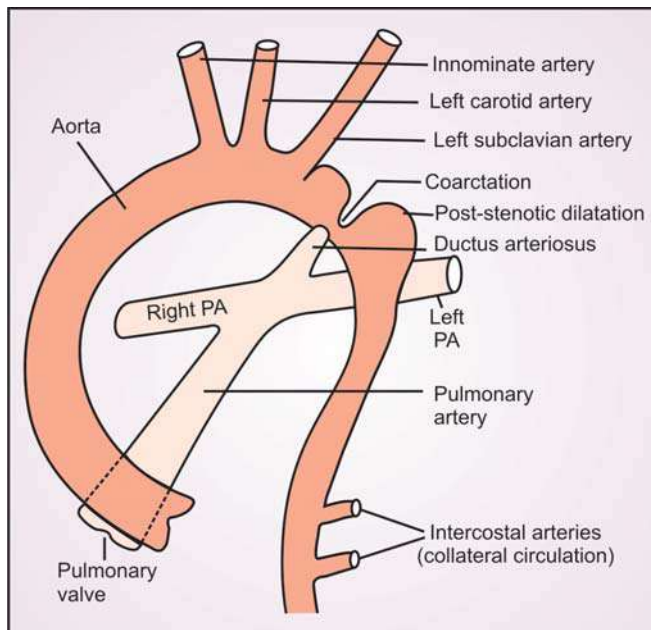

Fig. 22.17: Adult (postductal) type of coarctation of aorta. Note the collaterals which spare the infant from left ventricular failure

systolic and diastolic pressures. Since there are no collaterals because of the situation of the coarctation, the infant becomes immediately symptomatic with congestive cardiac failure.

In the so-called “postductal (adult) type”, development of collaterals connecting branches of the subclavian artery to the arteries which arise from the aorta, distal level of coarctation spares the infant from left ventricular failure (Fig. 22.17).

Clinical Features

In severe cases, usually of preductal type, the infant may present with congestive cardiac failure in first 1 to 3 weeks. Manifestations include feeding difficulty, dyspnea, failure to thrive, pitting edema, gallop rhythm and rarely differential cyanosis due to the PDA. Heart murmurs, depending on the associated cardiac conditions such as VSD, may be heard. A systolic murmur is usually found over the interscapular area.

In postductal type, manifestations developing in later childhood may include fatigue, cramps, intermittent claudication, headache, weakness and exertional dyspnea. In some cases, overgrowth of upper limbs and chest, may occur.

The most dependable physical finding is the weak, delayed and even absent femoral arteries compared to the strong brachial arteries. The blood pressure in the arms is much higher than in the legs (this observation is of significance only after 1 year of age). Occasionally, due to involvement of the left subclavian artery, left brachial pulse may be weaker and the blood pressure in the left arm lower than on the right side. Dilated and tortuous collaterals may be seen over the interscapular area in older children. It is called *Suzman sign*.

In uncomplicated coarctation, an ejection systolic murmur (grade 2/6) is heard at the aortic area and the lower left sternal border. A systolic murmur in the interscapular area is considered pathognomonic of the coarctation.

Diagnosis

X-ray chest findings include some left ventricular enlargement, notching of the ribs caused by intercostal collaterals and “E” sign on barium swallow. The first arch of the “E” is due to dilatation of aorta before the coarctation, the second due to poststenotic dilatation and the middle due to the coarctation *per se*.

ECG may be normal or suggestive of right ventricular hypertrophy, particularly in infants.

Echocardiography (realtime 2-dimensional) may visualize the coarctation directly. Only indirect evidence of coarctation may be forthcoming from the M-mode echocardiography.

Cardiac catheterization and *angiocardiography* demonstrate the location and severity of the coarctation and the adequacy of the collaterals.

Treatment

Medical management consists in tackling CCF and hypertension, dilatation of the associated PDA with a constant infusion of prostaglandin E1 in critical situations, and restriction of strenuous exercise. Antibiotic prophylaxis against bacterial endocarditis is desirable.

The best age for surgery is 3 to 5 years, provided that significant systemic hypertension has not developed. Corrective surgery consists of resection of the coarctated area and end-to-end anastomosis,

using a dacron graft or, preferably, subclavian flap. With the latter, chances of development of recoarctation in later life are considerably reduced.

Prognosis

If CCF develops in neonatal period or early in infancy, death is a rule unless vigorous treatment is offered. If the infant survives, he may do well without surgery for some years.

If no CCF occurs during the neonatal period or early infancy, the child may do well without surgery throughout childhood and adolescence.

Hypertensive cardiovascular disease and encephalopathy, bacterial endocarditis and, intracranial bleeding may prove fatal complications.

4 CONGENITAL HEART DISEASE (CHD) AND NEUROLOGIC COMPLICATIONS

CHD may be accompanied by developmental anomalies elsewhere. In addition, it is vulnerable to several acquired neurologic complications. Cardiac surgery in CHD involves intricate procedure employing a cardiopulmonary bypass and/or total circulatory arrest. Such stressful events can further cause various neurologic complications (Table 22.8).

Whereas early (before the first birthday) operative surgery on CHD considerably safeguards from development of neurologic complications preoperatively, special action is required to be taken to prevent

complications arising out of the surgery. Some of the strategies developed to minimize CNS injury from surgery for CHD include:

- Minimum use of circulatory arrest.
- Use of pH-stat technique during hypothermic bypass.
- Avoidance of postcardiopulmonary bypass hypothermia.

RHEUMATIC FEVER

Rheumatic fever, a disease state that occurs following a streptococcal throat infection, is an important cause of acquired heart disease in children. It can be defined as a poststreptococcal immune-mediated disorder occurring as a result of cross-reaction between the connective tissue of the body and the antibodies produced against streptococcal cell wall proteins and sugars resulting in varied combination of specific clinical features which constitute rheumatic fever.

Epidemiology

The incidence of rheumatic fever is closely related to the incidence of group A streptococcal pharyngitis. It is more common in developing countries than in developed countries. Though the disease has been controlled in the western countries by improved sanitary measures and primary prevention, it has recurred in recent times. The reported incidence in these countries is 0.3% of general population. In the crowded population, the incidence is about 1-3%. Rheumatic heart disease is the only sequelae of rheumatic fever. An Indian council of medical research (ICMR) survey has recorded an incidence of 5.3/1000 children aged between 6-16 years.

Rheumatic fever is more common in the age group of 5-15 years. Both the sexes are equally affected, although the sequelae of the disease, mitral stenosis and chorea, are more common in females.

Various predisposing factors are poor socio-economic status, overcrowding (orphanages, military recruits, etc.) and unhygienic living conditions. It is more common during fall, winter and early spring, coinciding with increased incidence of streptococcal infections.

Etiopathogenesis

Despite significant improvement in understanding the disease in recent times, the etiopathogenesis of rheumatic fever is not clear. However, the available

Table 22.8: Neurologic complications of congenital heart disease (CHD)

- Accompanying developmental neurologic anomalies
- Acquired neurologic lesions

Preoperative

Chronic hypoxia: impaired cognitive outcome

Global ischemia: Poor systemic perfusion or intense erythrocytosis with high hyperviscosity causing seizures, disorientation or excessive irritability

Acute focal ischemia: Cerebrovascular accident (CVA) from arterial or venous thrombosis, paradoxical embolization, direct embolization.

Infections: Brain abscess, infective endocarditis causing mycotic aneurysms

Intraoperative/Postoperative

Hypoxic-ischemic encephalopathy (HIE)

Seizures

Stroke

Movement disorders

data suggest that it occurs following group A beta hemolytic *Streptococcus* throat infection. The observations, preceding streptococcal throat infection as evidenced by the markers of streptococcal infection, seasonal variations of the rheumatic fever coinciding with increased incidence of streptococcal throat infection, and effectiveness of penicillin prophylaxis in preventing the rheumatic recurrence suggest association with group A streptococcal throat infection. However, the organism has not been isolated from either joints, blood or the heart.

The hypotheses postulated to explain the pathogenesis of rheumatic fever following streptococcal infection include toxic effects of the extracellular toxins of the organism and an abnormal immune response. The available data do not support possible toxic effect of the toxins on the humans target organs. On the other hand abnormal immune response of the human host to some still unidentified components of group A *Streptococcus* is more accepted as a possible pathogenic mechanism. The occurrence of the rheumatic fever after a latent period following streptococcal throat infection gives credence to the immune mediated mechanism. This hypothesis is further supported by the observations that group streptococcal M proteins share certain amino acid sequence with some human hosts. M proteins of the organism is the virulence factor and it is responsible for the organism's ability to result in the phagocytosis. The similar amino acid sequence in some individuals has been thought to be responsible for cross reaction between the organism and its human host. The presence of common antibodies to the antigens found in the group A *Streptococcus* cell membrane, in the caudate nucleus of the brain in patients with Sydenham's chorea further support the abnormal autoimmune mechanism responsible for central nervous system manifestations of rheumatic fever. The susceptibility of the human to the risk of rheumatic fever is not same in all individuals. Increased susceptibility for the development of rheumatic fever and subsequent rheumatic heart disease among certain high-risk individuals suggest possible genetic predisposition. This is supported by the presence of a specific alloantigen on the surface of non-T lymphocytes in 70-90% of individuals with rheumatic fever compared to fewer than 30% of nonrheumatic individuals. The marker was found to

be more common in families of rheumatic individuals. The reason for this is not known. Human leukocyte antigen (HLA) studies suggest an association with HLA-DR3.

Clinical Features

No specific clinical manifestation or laboratory test unequivocally establishes the diagnosis of rheumatic fever. Hence, set criteria for making the diagnosis have been laid down. These modified Jones criteria (revised) as per Table 22.9 are currently followed all over the world to make clinical diagnosis of rheumatic fever. The guidelines include major criteria, minor criteria and essential criteria. Major criteria are basically the major and common clinical features of rheumatic fever. Minor criteria are supportive of rheumatic fever in the presence of some major criteria. However, the most important aspect of this guidelines is the necessity of having an essential or a definitive evidence of preceding streptococcal infection. Two major or one major and two minor criteria, in the presence of essential criteria are required to make the diagnosis of acute rheumatic fever.

The typical clinical picture of rheumatic fever is that a child suffers from streptococcal throat infection, which improves either spontaneously or with treatment. One to few weeks later the child develops fever along with other clinical features of rheumatic fever. The guidelines are meant for making

4

Table 22.9: Modified Jones criteria (revised) for the diagnosis of rheumatic fever

Major	Minor
1. Carditis	<i>Clinical</i>
2. Polyarthritits (Migratory)	1. Fever
3. Chorea	2. Arthralgia
4. Subcutaneous nodules	3. Previous rheumatic fever or rheumatic heart disease
5. Erythema marginatum	<i>Investigative</i>
	1. Prolonged P-R interval in the ECG
	2. Increased ESR or presence of C-reactive proteins (CRP)
	<i>Essential criteria</i>
Evidence of preceding group A streptococcal infection (culture, rapid antigen, antibody rise/elevation)	

a correct diagnosis as it has prognostic and therapeutic implications. However in exceptional situation the diagnosis can be still considered without fully satisfying the criteria. These exceptions for diagnosing rheumatic fever are chorea, insidious or late onset carditis and rheumatic recurrence.

As chorea is a late manifestation, the other features of rheumatic fever may not be present along with it. In the absence of other causes, it can be considered rheumatic chorea. Even the requirement of preceding streptococcal infection can be ignored. Similarly, insidious or late onset of carditis can be considered as rheumatic carditis, provided other causes are ruled out. In this case too, requirement of preceding streptococcal infection can be ignored. About rheumatic recurrence, in patients with documented rheumatic heart disease or prior rheumatic fever, the presence of one major criteria or of fever, arthralgia, or elevated acute phase reactants suggest a presumptive diagnosis of recurrence. However, the evidence of preceding streptococcal infection is necessary.

Major Criteria

Carditis Carditis is one of the major criterias. Rheumatic carditis is basically a pancarditis involving endocardium, myocardium and pericardium. It occurs in 50-60% of patients with acute rheumatic fever. It is an early manifestation with most of the patients developing carditis within first two weeks of life. Involvement of all three structural components of the heart results in clinical manifestation of either all or any one or two of the components. However, the common manifestations of rheumatic fever are due to involvement of the endocardium. The clinical manifestations of endocardial involvement is basically valvular insufficiency. The most commonly affected valve is mitral valve. Most often it is affected alone and in some cases, it occurs in combination with aortic valves. Isolated aortic valve involvement is rare. Tricuspid and pulmonary valve involvement is unusual. Rheumatic carditis is either mild or severe and the clinical features depend upon the severity. The clinical features include pansystolic murmur of mitral insufficiency, apical mid diastolic murmur or basal diastolic murmur. If tricuspid regurgitation is present, a low-grade holosystolic murmur is heard along lower left sternal border. In severe carditis, acute volume overload on the left ventricle can result

in left ventricular failure. Heart failure is the major cause of mortality in acute rheumatic fever. Myocarditis of acute rheumatic fever presents with soft first heart sound, S3 gallop, congestive cardiac failure, Carey coomb's murmur and cardiac enlargement. The features suggestive of pericarditis include pericardial chest pains, pericardial rub and may have minimal effusion.

Carditis is an important manifestation of acute rheumatic fever and it is the only acute manifestation that result in chronic changes. It predisposes to the only sequelae of the acute rheumatic fever, rheumatic heart disease. Chronic changes result in scarring of the valves and even calcification of the valves in the long run and result in stenosis.

Polyarthrits It is an early manifestation and occurs in 70-75% of cases. Rheumatic arthritis is a polyarthrits. It is the most confusing among the major criteria and results in more diagnostic error than any of the other manifestations. It is a migratory polyarthrits involving the large joints like knees, ankles, elbows and wrists. It rarely involves small joints like fingers, toes, or spine. The arthritis of rheumatic fever is exquisitely tender. The joints are swollen, red, severely tender and movements are limited. In an untreated case, symptoms usually last about a week. The arthritis does not result in chronic joint disease or destruction. If anti-inflammatory drug therapy is initiated, the signs and symptoms disappear rapidly in 12-24 hours. This is a therapeutic approach, which helps in diagnosing and differentiating rheumatic arthritis from other causes of arthritis. If patient does not respond to the anti-inflammatory therapy, it is unlikely to be rheumatic arthritis. Prior anti-inflammatory therapy may eliminate the classical migratory nature of the poly-arthritis. Joint effusion may occur and the joint aspiration shows polymorphonuclear leukocytosis. However, it is a nonspecific finding and not essentially required.

Rheumatic (Sydenham's) Chorea It is a late manifestation of rheumatic fever, occurring much later than the other manifestations. It usually occurs about three months after the acute rheumatic fever. The choreoathetoid movements may begin very subtly, making the early diagnosis difficult. Early manifestations include clumsiness and it can be elicited by enquiring from the parents and children.

Table 22.10: Various tests for the diagnosis of rheumatic (Sydenham's) chorea

<i>Finger-nose test</i>
<i>Buttoning the clothes test</i>
<i>Dinner-fork posturing</i> of the outstretched hands (Fig. 22.18)
<i>Pronator test:</i> Pronation of forearm when the hands are raised above the head (Pronator test)
<i>Milkmaid grip:</i> Alternating relaxation and tightening of handshake
<i>Darting tongue:</i> Tongue keeps moving like a "bag of worms" on protruding
<i>Audible clicks during speech</i>
Clumsiness or inability in clear, organized writing (Fig. 22.19)
Ataxia
Counting the digits test
Sustained hung-up or double knee jerk

In school going children, deterioration of the handwriting is the best sign suggestive of chorea. The characteristic chorea movement consists of purposeless, jerky movements resulting in deranged speech, muscular incoordination, awkward gait and weakness (Table 22.10). Emotional lability is usually seen and child may develop depression also. As a result of chorea, the child may not be able to carry on schooling and some daily work. Chorea is usually self-limiting disorder. Untreated it subsides in few weeks to a month or more. Recurrences are known. It is important to differentiate Sydenham's chorea from other movement disorders and also to rule out other causes of chorea. It is an exception to the diagnosis of acute rheumatic fever without satisfying all the criteria necessary for the diagnosis.



Fig. 22.18: Dinner-fork sign in rheumatic chorea. Note the flexion at the wrist and extension of the fingers in the typical chorea hands

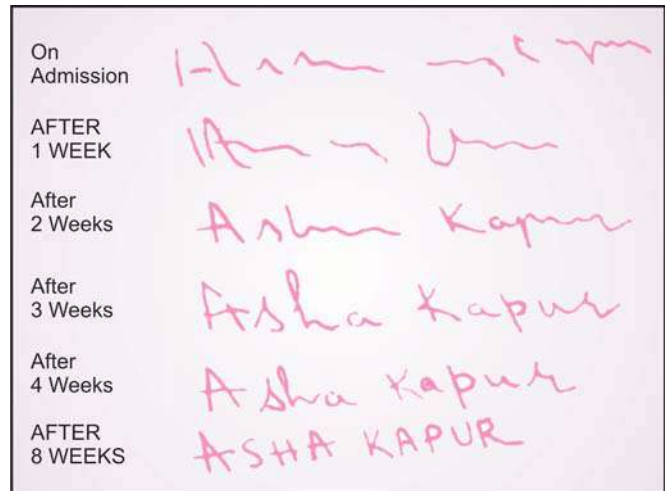

Fig. 22.19: Serial writings on hospitalization and during the course of recovery of a 13-year-old convent-going girl suffering from rheumatic chorea

Subcutaneous Nodules Subcutaneous nodules are a late manifestation. They are seen in about 3.5% of cases and usually appear around 6 weeks. They are infrequent and commonly observed in patients with severe carditis. Subcutaneous nodules are pea-sized, firm and non-tender nodules. They appear on bony prominence like knees, elbows, shins, over the spine and occiput. They disappear in few days to weeks. They are better palpated than seen (Figs 22.20 and 22.21).

Erythema Marginatum It is very infrequent finding and difficult to diagnose. It may start as a nonspecific



Figs 22.20 and 22.21: Rheumatic (subcutaneous) nodules. Besides over the extensor surface of wrist, elbow and knee joints, these shot-like hard bodies may be detected in occipital region or over spinous processes of thoracic and lumbar vertebrae

pink macules over the trunk. With the appearance of more rashes they spread and fuse each other to form a serpiginous outline. It is a non-blanching, evanescent rash and difficult to identify in individuals with dark complexion.

Minor Criteria

Minor criteria include both clinical and laboratory parameters. They are less sensitive and specific and hence they are just contributory findings in the diagnosis.

Fever It is seen in almost all cases of acute rheumatic fever and usually it is of mild to moderate grade. However it is very nonspecific and could be a manifestation of any other infection.

4 *Arthralgia* Pain in a joint without any other signs of inflammation, like fever, is very nonspecific. It should not be used as a minor criterion when polyarthritis is included as a major criterion.

Laboratory manifestations These include elevated erythrocyte sedimentation rate (ESR), and positive C-reactive protein and prolonged PR interval. ESR is raised in all patients with acute rheumatic fever and it remains for a prolonged period. Similarly C-reactive protein is also elevated in all patients. Prolonged P-R interval on electrocardiogram is also a nonspecific finding and may occur in many conditions. There can be evidence of varying degrees of heart block also. However complete heart block is extremely rare in acute rheumatic fever.

Essential Criteria

This is the cornerstone of modified Jones criteria and around it is that all other criteria are built on. The preceding group A streptococcal infection is documented by either positive throat culture, a history of scarlet fever or elevated streptococcal antibodies. Among them the most reliable is estimation of antibodies against the group A streptococci. Various antistreptococcal antibodies are antistreptolysin (ASO), antihyaluronidase (AHD), antideoxyribonuclease (AD), streptokinase antibodies and many others. Antistreptolysin 'O' titers (ASO) are the commonly used antibody tests. ASO titers are significantly raised following an acute

group A streptococcal infection. Drawbacks of ASO titers is that it only suggest whether there was a preceding group A streptococcal infection or not and nothing else. High titers are considered more significant in making the diagnosis, but low titres do not exactly rule out the diagnosis. Rising titers of ASO is a strong evidence of a recent streptococcal infection than a single titer result. The ASO titer reaches its peak by 3-6 weeks.

Positive throat swab culture is the gold standard for confirmation of the presence of groups A streptococcal infection. All patients with acute rheumatic fever should have at least one throat swab culture before the initiation of antibiotics. The drawback of positive throat swab culture include low positive results due to improper sample collection and storage, prior antibiotic therapy and it only suggests whether there was a throat infection or not. It could be positive even in an individual without the evidence of acute rheumatic fever.

Other Investigations

Chest roentgenogram may show evidence cardiomegaly. Non-specific elevations of gammaglobulin may be seen. There may be mild leucocytosis.

Role of Echocardiography in Acute Rheumatic Fever Though echocardiography findings has not been included in the criteria for diagnosing acute rheumatic fever, it has a major role to play in the diagnosis of subclinical and mild carditis cases which are usually missed on clinical examination. It also helps in assessing the severing of the cardiac abnormalities and subsequently in assessing and follow-up of patients with chronic valvular disease. It is also helpful in diagnosing carditis in rheumatic recurrence.

New Diagnostic Modalities

At least three new diagnostic modalities for confirming presence of carditis are now available Table 22.11.

Differential Diagnosis

Rheumatic fever has to be differentiated from various other disorders which can manifest with similar clinical features. These disorders include rheumatoid arthritis, viral arthritis, collagen vascular disorders

Table 22.11: Role of new modalities for confirming presence of rheumatic carditis

Modality	Remarks
Echocardiography	Of remarkable utility in diagnosing subclinical or mild carditis (mild valvular regurgitation) that is usually missed by clinical examination.
Artificial subcutaneous nodule	Appearance of artificial subcutaneous nodules 4-10 days after injection of auto-test logous blood is 100% specific but only 62% sensitive. The time lag of 4-10 days is its negative point for wide spread use.
Endomyocardial biopsy	A positive biopsy showing Aschoff nodules or histiocytes establishes the diagnosis but a negative biopsy (which is more often the case) does not rule out carditis. Hence, not quite useful as a routine diagnostic procedure.

(e.g. SLE), infective endocarditis, Lyme's disease etc. Differentiating rheumatoid arthritis becomes more important when a patient presents with arthritis as a major manifestation. Differentiating from infective endocarditis is most crucial in the management of acute carditis. At times it is very difficult, especially in cases of rheumatic recurrence in a case of preexisting rheumatic heart disease. Echocardiogram and blood culture are useful investigations in these situations.

Complications

The only complication and long-term sequelae of acute rheumatic fever is rheumatic valvular heart disease.

Treatment

The treatment of acute rheumatic fever includes supportive therapy, treatment of clinical manifestations using anti-inflammatory drugs and treatment of group-A streptococcal infection.

Bed Rest All patients with acute rheumatic fever, especially the ones, with carditis should be advised strict bed rest till the symptoms are subsided. Ideally the bed rest should be given for 6-8 weeks period, the period generally needed for rheumatic activity

to subside. In the absence of carditis, however, patient can be ambulated earlier. Presence of congestive cardiac failure may require prolonged bed rest.

Diet Adequate proteins, vitamins and micronutrients should be supplemented. In the absence of carditis, there is no need for restricting the salt. Salt restriction may be required in the presence of congestive cardiac failure.

Anti-inflammatory Drug Therapy Anti-inflammatory agents are the cornerstone in the management of acute rheumatic fever. These agents are required to suppress the ongoing inflammation and provide symptomatic relief. Salicylates and steroid are the drugs used. Aspirin is the drug of choice. Aspirin results in reduction in fever, pain and swelling of the joints dramatically. The joint symptoms disappear within 12-24 hours. The dose is 90-120 mg/kg/day in four divided doses. This dosage is expected to maintain a blood level of 20-25 µg/dl. If the facilities are available to estimate blood salicylate level, the dosage is adjusted to achieve and maintain this blood level. The total duration of therapy is about 12 weeks to completely suppress the inflammation. The full dosage should be continued for about 10 weeks and then tapered and stopped over next 2 weeks. When the patient is on aspirin therapy, it is very important to monitor for drug toxicity both clinically and by the estimation of blood salicylate levels. The earliest sign of salicylate toxicity is tinnitus. When patient complains of tinnitus, look for other manifestations of salicylism, stop the drug and ask for blood salicylate level. If patient develops toxicity, the dosage has to be reduced and continued with monitoring. No other anti-inflammatory drugs have been proved to be beneficial in the treatment of acute rheumatic fever.

Steroids are not generally required in the management of acute carditis. They do not result in better improvement. The indications for steroid therapy in acute rheumatic fever include carditis with congestive cardiac failure and sometimes in severe carditis. Steroids are helpful in controlling the acute inflammatory process, but do not modify the incidence or severity of the residual chronic rheumatic heart disease. Generally steroid therapy is required for 4 weeks duration. Steroid that is most commonly

used is prednisolone. Start with 2 mg/kg/day, in divided doses. Steroids should be slowly tapered and stopped. When steroids and aspirin are used together in a given patient, introduce aspirin when the steroids are being tapered; start aspirin on the last week of steroid therapy and continue over a period of time. This helps in preventing rebound rheumatic activity and also the adverse effects of prolonged steroid therapy.

Treatment of Congestive Cardiac Failure CCF due to severe carditis requires aggressive treatment with drugs. Start with diuretics and use digoxin as required. Some patients may develop intractable congestive cardiac failure and they may not respond to the medical therapy. In these cases, surgical therapy in the form of valve replacement with prosthetic valve or valvuloplasty may be required. It is important to remember that surgical treatment is an integral part in the management of acute rheumatic fever, though it is required rarely.

Treatment of Chorea Reassure the parents that it is a self-limiting condition. Advise both physical and mental rest for sometime. Consider using drugs if the symptoms are severe. The drugs used are phenobarbitone, chlorpromazine, diazepam and haloperidol. Start with phenobarbitone and consider using other drugs as required. Haloperidol is advised for severe cases only. However, it is necessary to watch for side effects. There is no obvious role for aspirin or steroids, though some observers have documented better improvement on adding steroids into the treatment regimen.

Treatment of Group-A Streptococcal Infection Take throat swab samples for culturing and start the patient on penicillin therapy. This is to eradicate the streptococcal infection. Procaine penicillin—400,000 units, intramuscularly, twice daily, for 10 days is necessary. Alternatively use oral penicillin 4 lakh units (250mg), every 4-6 hourly for 10 days. After the completion of the therapy, start penicillin prophylaxis every 21 days with benzathine penicillin 1.2mg units. In penicillin sensitive cases use erythromycin or tetracycline.

Rheumatic Prophylaxis

It would be ideal to prevent rheumatic fever by primary prophylaxis. The primary prophylaxis

includes identification and treatment of streptococcal sore throat with penicillin therapy. Beside penicillin therapy, primary prophylaxis requires educating the public on the dangers of streptococcal sore throat infection and need for treatment. Penicillin G, 0.6-1.2 mg units, intramuscularly once daily or oral therapy with penicillin V, erythromycin, amoxycillin, ampicillin, cephalexin, clindamycin or nafcillin for 10 days is necessary. Ten full days therapy is a must, especially when oral drugs are used.

Secondary prophylaxis consists of using long-acting penicillin, benzathine penicillin 1.2 mega units once in every 21 days. In smaller children less than 27 kg use 0.6 mega units. Other drugs, which can be used for secondary prophylaxis, include penicillin V, 250 mg twice daily, sulfadiazine 500 mg to 1.0 gm daily or erythromycin 250 mg twice daily. Ideally the secondary prophylaxis should be continued life long. However some experts have advised to give it till 40 years of age. In patients with no residual lesion, one may consider giving secondary prophylaxis for a limited duration. Appropriate prophylaxis against infective endocarditis is very much essential.

Prognosis

Prognosis depends upon the severity of the disease, especially the carditis. Children with severe carditis are at increased risk of chronic sequelae in the form of rheumatic valvular heart disease. Mortality rate is high in patients who develop congestive cardiac failure. Infective endocarditis can complicate the course and increase both morbidity and mortality. Patients with mild carditis may improve well. The mitral regurgitation may spontaneously disappear over a period of time (usually 1-2 years). However, aortic regurgitation may not correct spontaneously. Ideal is to prevent occurrence of rheumatic fever with early diagnosis and treatment.

RHEUMATIC HEART DISEASE

The only chronic sequelae of rheumatic fever is rheumatic heart disease. It is the commonest acquired heart disease in children. The disease is basically valvular heart disease affecting the heart valves either in isolation or in combination. Mitral valve is the commonly involved followed by aortic valves. In the following section, the rheumatic valvular heart disease is briefly discussed.

Mitral Regurgitation

Mitral regurgitation is the commonest and earliest manifestation of rheumatic carditis. Varying degree of mitral regurgitation occur in almost all cases of acute carditis.

Pathophysiology The structural changes that occur in the mitral valves are shortening and thickening of the chordae tendinae. The abnormal valves result in regurgitation. Persistent high volume overload results in enlargement of the left ventricle and subsequently left atrium is also enlarged due to regurgitation of the blood. The persistent mitral insufficiency results in elevated pulmonary pressure (pulmonary hypertension), right ventricular enlargement and right heart failure. The mitral regurgitation that occurs during acute rheumatic fever usually subside by about a year as evidenced by disappearance of mitral regurgitation murmur. Most often the mitral regurgitation is mild to moderate and remains asymptomatic for a longer time.

Clinical Features Clinical manifestations are dependent on the severity. Patients with mild regurgitation may be symptomatic. Patients with moderate to severe regurgitation develop easy fatigability and dyspnoea on exertion. Others include symptoms of congestive cardiac failure, palpitation and weakness. On examination, cardia is enlarged, apex is displaced downwards and outwards with a heaving apical impulse and often with an apical thrill. The first heart sound is normal, second heart sound is accentuated with augmented pulmonary component, a pansystolic murmur is heard at the apex with radiation to the left axilla (Fig. 22.22). Third heart sound may be heard at the apex, indicating increased early rapid filling of the left ventricle. In severe mitral regurgitation, diastolic murmur may be heard at apex due to large blood flow from left atrium to the left ventricle. The diastolic murmur is of shorter duration and ends in mid diastole. It may be associated with diastolic thrill.

Diagnosis *Chest roentgenogram* shows left ventricular enlargement, left atrial enlargement and features of pulmonary venous hypertension. *Electrocardiogram* is normal in mild and asymptomatic cases with normal axis. In moderate to severe cases, ECG shows left ventricular hypertrophy, left atrial hypertrophy and

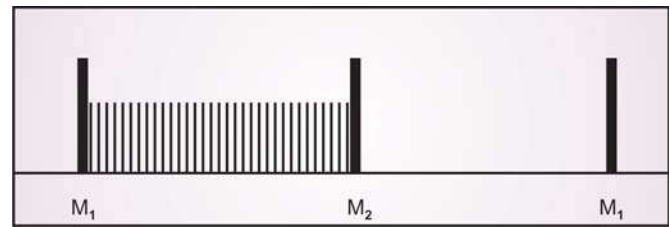

Fig. 22.22: Classical pansystolic murmur of mitral incompetence

features of right ventricular hypertrophy also in severe cases. It may also show arrhythmic changes. *Echocardiogram* shows enlarged left atrium and the ventricle. *Doppler echo* shows the severity of mitral regurgitation.

Differential Diagnosis Beside rheumatic etiology, various other causes of mitral regurgitation in children include septum primum type of atrial septal defect, papillary muscle dysfunction, Marfan syndrome, Hurler syndrome, anomalous origin of left coronary artery from pulmonary artery, congenital mitral regurgitation, left ventricular fibroelastosis and septum secundum type of atrial septal defect with floppy mitral valve.

Treatment Medical management of mitral regurgitation includes treatment of congestive cardiac failure, prophylaxis and treatment of infective endocarditis. Congestive cardiac failure requires digoxin and lasix. Afterload reducing agents are useful in the long term management. Surgical treatment is indicated for severe mitral regurgitation resulting in recurrent heart failure, progressive cardiomegaly often with pulmonary hypertension. The surgical measures include prosthetic mitral valve replacement mainly. Annuloplasty has been found to provide good results in older children, though valve replacement may be required later.

Complications They include repeated congestive cardiac failure, infective endocarditis, pulmonary hypertension, arrhythmias, atrial fibrillation, atrial flutter and ventricular extrasystole.

Mitral Stenosis

The rheumatic mitral stenosis is less common in pediatric age group. Unlike mitral regurgitation, mitral stenosis develops late in children. It takes

usually more than 10 years to develop following acute rheumatic carditis. However, "Juvenile mitral stenosis", an entity coined to describe rapid occurrence of mitral stenosis in children, occur rapidly within few years after the carditis. It is more common in south Indian children, Srilanka and some parts in Asia.

Pathophysiology and Hemodynamics Mitral stenosis result from fibrosis of the mitral ring, commissural adhesions, contractures of the valve leaflets, chordae tendinae and papillary muscles. The resultant reduction in valvular orifice causes an increased pressure and volume load on the left atrium, resulting in its enlargement. Persistent high pressure leads to pulmonary venous hypertension followed by pulmonary arterial hypertension, right atrial and right ventricular enlargement. This results in right heart failure.

Clinical Features The development of mitral stenosis usually takes more than 10 years. However, children with juvenile mitral stenosis present early. The symptoms usually start appearing when the orifice size is reduced to 25% or less of the expected normal. Children with mild stenosis are asymptomatic or present with mild symptoms like tiredness and dyspnea. Patients with severe mitral stenosis present with progressive exertional dyspnea or even dyspnea at rest, orthopnea, paroxysmal nocturnal dyspnea and palpitation. Hemoptysis can occur due to rupture of bronchial or bronchiolar veins. Blood streaked sputum may be seen in patients who develop pulmonary edema. In patients with chronic severe mitral stenosis, cyanosis and malar flush are noted. Features of congestive cardiac failure can occur in moderate to severe stenosis with pulmonary hypertension. Arrhythmias aggravate the symptoms of mitral stenosis.

Physical examination shows low volume pulses, distended neck veins, jugular venous pulse show prominent 'a' wave, dominant 'V' wave in the presence of tricuspid regurgitation and systolic pulsation of the liver. Precordium reveals normal sized heart in mild mitral stenosis. But in moderate to severe mitral stenosis, there will be moderate to huge cardiomegaly. Apical impulse is either normal or tapping type. Parasternal right ventricular type of lift may be present with high pulmonary pressure.

On auscultation, first heart sound is loud, an opening snap of mitral valve, best audible just medial to the apex is present. A long, low pitched, rumbling mitral diastolic murmur with presystolic accentuation is heard at the apex. The murmur may be absent in the presence of congestive heart failure. The absence of presystolic accentuation of the murmur is against the diagnosis of mitral stenosis. Second heart sound is loud in the presence of pulmonary hypertension. A pansystolic murmur of low intensity may be heard due to tricuspid regurgitation. Graham steel murmur (early diastolic murmur) of pulmonary insufficiency may be heard (Fig. 22.23).

Chest roentgenogram shows enlarged left atrium, right ventricle, plethoric pulmonary field and prominent pulmonary artery. Features of pulmonary edema may be seen. **Electrocardiogram** shows right axis deviation with right ventricular hypertrophy and prominent and notched "P" waves. **Echocardiography** show thickened mitral leaflets decreased EF slope, paradoxical posterior leaflet motion, dilation of left atrium, pulmonary artery, right ventricle and right atrium in severe cases. **Cardiac catheterization** quantifies the diastolic gradient across the mitral valve and the degree of elevated pulmonary pressure.

Management Medical management includes restriction of activity, treatment of congestive cardiac failure,

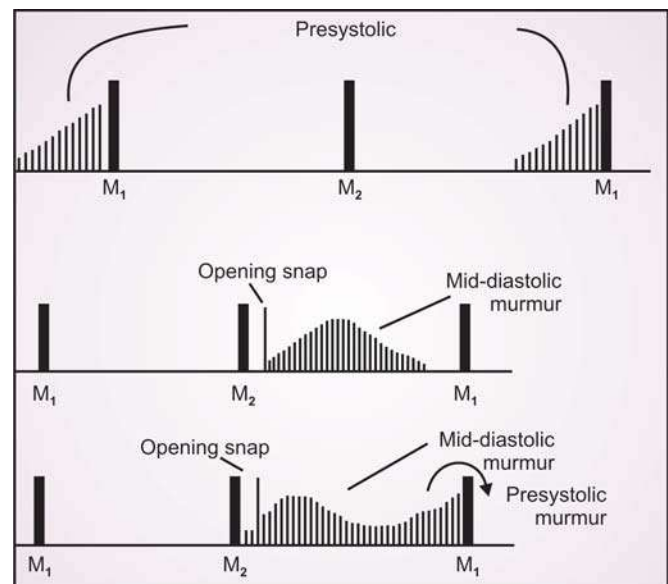

Fig. 22.23: Classical auscultatory findings of mitral stenosis

prophylaxis against rheumatic recurrence and infective endocarditis.

Surgical treatment is indicated in subjects with severe mitral stenosis, before the appearance of severe manifestations mentioned earlier. Closed mitral valvotomy is done to relieve the obstruction. It is still the commonest and best surgical approach. However its limitations is that it relieves commissural fusion but cannot relieve subvalvar fusion and shortening of the chordae tendinae. Hence it is less useful in patients with more of subvalvar fusion. Other procedure is balloon valvuloplasty. It is indicated in symptomatic patients with stenotic, pliable and non calcified valves without atrial arrhythmias or thrombi. Re-stenosis may warrant repeat valvotomy. A severely damaged valve may require replacement with prosthetic valve and life long anticoagulant therapy.

Rheumatic Aortic Valve Disease

After the mitral valve, the cardiac valve most often involved in rheumatic heart disease is the aortic valves. Aortic regurgitation is the manifestation. Rheumatic aortic stenosis doesn't occur in pediatric patients.

Aortic Regurgitation

Aortic regurgitation is the common type of rheumatic valvular disease after the mitral regurgitation. Isolated aortic regurgitation is rare and occurs in about 5-8% of the patients. On the other hand, combined mitral and aortic regurgitation is common.

Pathophysiology and Hemodynamics The aortic valvular disease occurs due to sclerosis of aortic valves, leading to shortening, distortion and retraction of the cusps, which causes inadequate closure during diastole. Consequently, hypertrophy of the left ventricle occurs. Regurgitation of the blood through the incompetent aortic valve result in increased left ventricular volume load. The left ventricle accommodates the extra volume by increased ventricular size. The dilatation of the left ventricle is directly proportionate to the degree of aortic leak. The regurgitation of blood results in impaired systemic blood flow (decreased cardiac output). Left ventricle tries to compensate for this decreased output by increased ejection during early part of the systole.

However, the significant aortic regurgitation results in low cardiac output. This results in wide peripheral pulse pressure and it can be identified as exaggerated arterial and arteriolar pulse pressure. In the initial stages, with the good left ventricular function, even the moderate aortic regurgitation is tolerated. However impaired ventricular function results in increased regurgitation, increased left atrial pressure, which in turn results in pulmonary congestion. Progressive left ventricular dilation results in mitral regurgitation.

Clinical Features Mild to moderate aortic regurgitation with good ventricular function does not give rise to symptoms. However, persistent and increased regurgitation results in onset of the symptoms. Palpitation is the main symptom of aortic regurgitation. Others include exercise intolerance and exertional dyspnea and paroxysmal dyspnea. Angina may occur later. The signs of wide pulse pressure are evident on the physical examination. The diastolic blood pressure may be even zero. Other peripheral signs of aortic regurgitation have been listed below (Table 22.12).

Precordial examination shows left ventricular type of cardiac enlargement with heaving apical impulse and seesaw movements of the chest in severe cases. The first heart sound is soft and aortic component of second sound is either audible or masked by the

Table 22.12: Peripheral signs of aortic regurgitation

<i>Corrigan's sign</i> —Prominent carotid pulsations.
<i>Corrigan or water hammer pulses</i> —Sudden falling of the pulse when the limb is elevated from supine position above the level of heart.
<i>Musset's sign</i> —Nodding of the head with each systole
<i>Hill's sign</i> —Increased difference in blood pressure between brachial and femoral arteries. (Difference of <20 mm Hg—normal, 20-40 mm Hg—mild aortic regurgitation, 40-60 mm Hg – moderate, > 60 mm Hg severe aortic regurgitation)
<i>Pistol shot sounds</i> —Sounds resembling pistol shot heard over the brachial or femoral artery without pressure.
<i>Duroziez's sign</i> —A combination of systolic and diastolic murmurs heard over the brachial or femoral artery on applying pressure on the artery. Application of pressure proximally produces systolic murmur and pressure distal to the chest piece produces a diastolic murmur.
Pulsations may be seen over the uvula, tip of the tongue, ear lobule and pupils.

murmur. A diastolic thrill may be felt. The typical aortic regurgitation murmur is a diastolic murmur, begins immediately after the second heart sound and continues until the late diastole. It is a hollow, high pitched blowing quality murmur, best heard along left upper and mid sternal border with radiation to the apex and aortic area. The murmur is better appreciated with the diaphragm of the stethoscope firmly placed over the chest with patient leaning forward. An ejection systolic murmur, with preceding click may be heard due to large stroke volume. An apical presystolic murmur (Austin flint murmur) of mitral origin may be heard.

Chest roentgenogram shows enlargement of the left ventricle and dilatation of the aorta. *Electrocardiogram* may be normal in mild cases and shows evidence of left ventricular hypertrophy with strain pattern in severe cases. *Echocardiogram* shows large left ventricle, dilated aorta and diastolic mitral valve flutter caused by regurgitant flow hitting the valve leaflets. *Doppler* study demonstrates the severity of aortic regurgitation.

Treatment The medical management consists of prophylaxis against rheumatic recurrence and infective endocarditis. Ideally, the surgery should be done before the patient develop signs of left ventricular failure, angina or pulmonary edema. The surgery consists of aortic valve replacement by homograft or a prosthetic valve. For patients who develop congestive heart failure, vasodilators, mainly the angiotensin converting enzyme inhibitors are useful. Use of digoxin increases the regurgitation and generally not recommended.

Prognosis Mild to moderate degrees of aortic regurgitation are well tolerated. Some patients may remain asymptomatic almost into the third and fourth decade.

RHEUMATIC TRICUSPID VALVE DISEASE

The tricuspid valve involvement is rare following rheumatic fever. Tricuspid disease occurs either alone or in combination with other valvular diseases.

TRICUSPID REGURGITATION

Isolated tricuspid regurgitation is rare. Most often it is seen in association with other valvular heart disease mainly mitral valve (mitral stenosis and mitral

regurgitation) and most often it is a functional regurgitation. Organic tricuspid regurgitation can occur with mitral regurgitation. Hemodynamically, the tricuspid regurgitation results in right atrial volume overload and consequent right atrial enlargement. Regurgitation of blood into the right ventricle results in right ventricular enlargement and pulmonary hypertension.

Clinical Features There is no specific symptomatology due to tricuspid regurgitation. Occasionally patient may complain of right hypochondrial pain due to congested liver. The signs include 'V' waves on the jugular venous pulse, systolic pulsation of the liver and blowing holosystolic murmur, best heard along the left lower sternal border. Signs of pulmonary hypertension may be present along with the of features of mitral valvular lesion.

Electrocardiogram shows right ventricular and right atrial hypertrophy. *Echocardiogram* and *Doppler* confirms the diagnosis and also document the severity of regurgitation.

Treatment Irrespective of whether the tricuspid regurgitation is organic or functional decongestive measures should be undertaken. This result in reduction in the regurgitation of the tricuspid regurgitation. If the tricuspid regurgitation is due to mitral valve disease, the corrective measures result in decrease or disappearance of tricuspid regurgitation. Rarely tricuspid regurgitation requires tricuspid valvuloplasty.

INFECTIVE ENDOCARDITIS

Infective endocarditis refers to the infection of endocardium of the heart including endocardium of the valves, mural endocardium or endothelium of the blood vessels. Previously it was called bacterial endocarditis, however as many other organisms other than bacteria also cause endocarditis, it has been labelled as infective endocarditis. It has significant mortality and also significantly influences the prognosis of underlying heart disease. It is a major complication of underlying heart disease.

Etiology

Streptococcus viridans was the commonest cause. However of late *Staphylococcus* has become increasingly more common and currently it is

responsible for a large number of cases. It is also a common cause in patients who do not have underlying heart disease. Other less common causes include *Streptococcus pneumoniae*, *Hemophilus* species, *Staphylococcus epidermidis*, *Coxiella burnetti*, chlamydial species, *Neisseria gonorrhoea*, fungus, rickettsiae and others.

Infective endocarditis predominantly occurs in patients with underlying heart disease: congenital or acquired. Rarely it occurs in normal heart, usually as a part of septicemia. Various risk factors for the occurrence of infective endocarditis include presence of an underlying heart disease, drug abuse, prosthetic heart valves, recent cardiac surgery, various interventions like dental procedures, cardiac catheterization, genitourinary procedures and infective process anywhere in the body.

Pathogenesis and Pathology

Pathogenesis generally depends on the virulence of the organism. Infective endocarditis usually starts in places where there is high velocity of blood ejection (through a hole or stenotic orifice like ventricular septal defect and aortic stenosis). The vegetation usually formed at the site of endocardial or intimal erosion that results from the turbulent blood flow. The bacteremia resulting from infection elsewhere in the body result in deposition of the bacteria on the endocardium and initiates the endocarditis. Endocarditis also results in immune mediated vasculitis and thrombocytopenia.

Clinical Features

Clinical features depend on the virulence of the organism and the severity of the disease. Depending upon the course, it can be either acute or sub acute. Prolonged fever, without any other manifestation, in patients with underlying heart disease may be the only clinical feature. Alternatively patient may present with high spiking fever, chills and rigors, night sweat and prostration. In most cases, however the presentation is in between these two. Patients present with persistent fever, with or without chills/rigors, generalized malaise, loss of appetite, loss of weight, myalgia, arthralgia, headache, nausea and vomiting. Patients may also develop congestive cardiac failure. New murmur or changing murmurs can occur and they are the important findings that give clues to the diagnosis while

evaluating the patients. Splenomegaly is a relatively common feature. Various thromboembolic complications include mainly central nervous system complications; brain abscess, embolism, mycotic aneurysms and hemorrhages, pulmonary and other systemic and peripheral embolus phenomenon resulting in renal infarct, systemic infarct and mesenteric embolisms. Myocardial abscesses and pericardial involvement can also occur. Especially with *Staphylococcus aureus* infection. Features of immunological response presenting as vasculitis are Osler nodes (tender pea-sized intradermal nodules in the pads of fingers and toes), Janeway lesions (painless erythematous or hemorrhagic lesions on palms and soles), splinter hemorrhages below the nail bed, petechiae over the skin, mucous membranes and retina (Roth's spot).

Investigations

Blood culture is the gold standard in the diagnosis of infective endocarditis. All other tests are complementary. Three to five samples collected separately from aseptically prepared sites can find positive growth in more than 95% of cases. As bacteremia is expected to be constant, timing of the sampling is not important. Anaerobic culturing is also necessary in all cases. In our country, unfortunately nearly 50% samples are negative. The major reason for negative blood culture is prior antibiotic therapy. Others include slow growing organisms, fungus, atypical and anaerobic organisms. The blood culture also helps in finding sensitivity pattern and helps in meticulous use of antibiotics. Other laboratory abnormalities include anemia, leucocytosis, raised ESR, C-reactive protein, microscopic hematuria, hypergammaglobulinemia, hypocomplementemia, cryoglobulinemia and positive rheumatoid factor.

Echocardiogram is another important diagnostic tool, especially when the blood culture is negative. The presence of vegetations is suggestive of infective endocarditis. It is very sensitive in identifying vegetations on mitral and aortic valves. It can identify vegetations measuring more than 2-mm size. Vegetations may not be visible in the early stage of the disease.

Complications

Patients with severe endocarditis can have many complications like perforation of the valve, rupture of chordae tendinae, acute valvular regurgitation due

to any of the above complications, thromboembolic phenomenon with systemic involvement, mycotic aneurysms and others.

Diagnosis

High index of suspicion in patients with underlying cardiac disease is important to make the diagnosis of infective endocarditis. Blood culture is the gold standard. However as discussed above, echocardiography has an important role, especially in cases of culture negative cases. Other investigations are complimentary to the blood culture.

Treatment

4

Infective endocarditis is a medical emergency. Patients require admission into the hospital and require prolonged antibiotic therapy and good supportive therapy. Delayed diagnosis and late initiation of treatment are the main reasons for complications and high mortality. Antibiotics should be administered in higher doses (5-20 times the minimum in vitro inhibiting concentration) to destroy the growing organisms in the vegetations. Minimum of 4-6 weeks of antibiotics are required. Depending upon the clinical response, laboratory response, and echocardiograph evaluation further continuation of the antibiotics should be decided. Before the availability of blood culture report and in blood culture negative cases, start broad-spectrum antibiotics to cover wide range of organisms. Start with high dose of Ampicillin and an aminoglycoside. Once blood culture report is available, choice of antibiotics should be as per the sensitivity pattern. Table 22.13 lists the antibiotic used in the treatment of infective endocarditis.

Table 22.13: Dosages of the drugs used in the treatment of Infective endocarditis

<i>Penicillin G</i>	200,000 to 300,000 units/kg/day, 4-6 hourly
<i>Gentamicin</i>	7.5 mg/kg/day, 8-12 hourly
<i>Amikacin</i>	15-25 mg/kg/day, 8-12 hourly
<i>Vancomycin</i>	60 mg/kg/day, 8-12 hourly
<i>Cloxacillin</i>	150-200 mg/kg/day, 4-6 hourly

For *Streptococcus viridans* use Penicillin G alone or Penicillin G and an aminoglycoside (Gentamicin or amikacin). For *Enterococcus* species use Penicillin G

or ampicillin with an gentamicin or amikacin. For *Staphylococcus aureus*, if methicillin sensitive, use cloxacillin and gentamicin/amikacin. If methicillin resistant, use vancomycin and gentamicin/amikacin. In severe cases, rifampicin may be used as an additional optional drug. Duration of therapy for *Staphylococcus aureus* endocarditis ranges from 6-8 weeks.

In culture negative endocarditis, use cloxacillin with gentamicin for 4-6 weeks. Use ampicillin as an optional drug. For fungal endocarditis the drugs used are amphotericin and flucytosine. The dose of amphotericin is 1.0 mg/kg/day. Start with 0.25 mg/kg/day and gradually increase. The maximum dose is 1.5 mg/kg/day. 5 Flucytosine–5–150 mg/kg/day, every 6 hourly orally. Surgery may be required to remove the vegetations. However, the success rate for surgical treatment is limited. It is more difficult to treat endocarditis in-patients with prosthetic valves. In these patients beside antibiotic therapy, prophylactic valve replacement may be necessary. Oral anticoagulants, instead of heparin should be used.

Surgical treatment may be required in some cases and it is an integral part in the treatment of infective endocarditis. Surgical interventions are required for mitral or aortic regurgitation leading to severe congestive cardiac failure, mycotic aneurysms, rupture of an aortic sinus, dehiscence of intracardiac patch. Other causes include failure to sterilize blood despite adequate antibiotic therapy, myocardial abscess and recurrent emboli. Other supportive measures include bed rest, nutritious diet, if present, treatment of congestive failure, monitoring and treatment of arrhythmias and any other co-existing problems.

Prognosis

The survival has significantly improved with the availability of potent antibiotics. However, inspite of adequate antibiotic therapy, the mortality rate remains at 20-25%. Delayed diagnosis and late initiation of therapy may become life threatening.

Prophylaxis and Prevention

The best method to prevent infective endocarditis is early appropriate surgical treatment of the underlying

heart disease. However, as it is not possible always prophylactic antibiotic therapy should help in reducing the incidence of infective endocarditis in susceptible patients. Proper hygiene and treatment of other foci of infections are also important.

Recommended antibiotics for various procedures are as follows:

Dental procedures and upper respiratory tract surgeries: Amoxicillin (Oral): 50 mg/kg 1 hour prior to surgery 25 mg/kg after the initial dose, erythromycin (Oral): 20 mg/kg 2 hour before the procedure and 10 mg/kg 6 hour after the initial dose or clindamycin: 10 mg/kg 1 hour before surgery and 5 mg/kg 6 hour after the initial dose.

Gastrointestinal and Genitourinary tract surgery: Ampicillin (IV/IM) – 150 mg/kg and gentamicin 2 mg/kg 30 minutes before the procedure. In high-risk patients repeat dose is required 6-8 hours after the procedure. For minor procedures, amoxicillin may be used. In penicillin allergy patients, parental vancomycin 20 mg/kg as infusion 1 hour prior to the procedure along with gentamicin should be given. For high-risk patients, vancomycin dose may be repeated 8 hours after the initial dose.

(High-risk patients include patients with prosthetic valves, previous endocarditis, and penicillin prophylaxis for rheumatic fever, surgically constructed systemic pulmonary shunts or conduits Figure 22.24.)

MITRAL VALVE PROLAPSE SYNDROME (BARLOW SYNDROME, FLOPPY OR BILLOWING MITRAL VALVE SYNDROME, LATE MITRAL SYSTOLIC MURMUR-SYSTOLIC CLICK SYNDROME)

This syndrome results from prolapse of one or both mitral valve cusps, the posterior one in particular, into the left atrial cavity towards the end of systole.

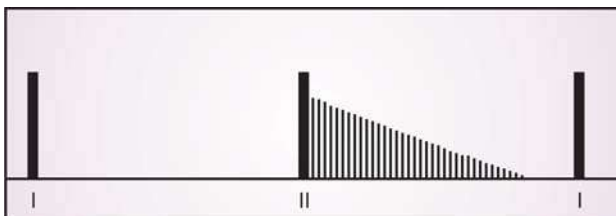

Fig. 22.24: Classical diastolic murmur of aortic incompetence

The condition is a nonspecific finding. Its most common origin is congenital. It may, however, be associated with rheumatic or viral myocarditis, or secundum atrial septal defect. Girls and siblings show higher incidence.

Auscultatory findings include a late mitral systolic murmur preceded by a mid-systolic click. At times, only click may be heard in the very subject with typical auscultatory findings. Arrhythmias may occur.

Classical ECG findings are diphasic T waves in leads II, III, VF and V6, in particular. ECG may, however, be normal. Chest X-ray is essentially normal. Echocardiogram (preferably 2-dimensional real time) shows typical posterior movement of the posterior mitral cusp during mid or late systole, or pansystolic prolapse of both anterior and posterior mitral cusps.

The syndrome is usually asymptomatic and non-progressive in childhood though chest pain may occur in some cases. The patient is at risk to develop infective endocarditis.

No specific therapy is indicated. Nevertheless, it is advisable to provide antibiotic prophylaxis against infective endocarditis during operative procedures, including dental extraction, etc.

PAROXYSMAL ATRIAL TACHYCARDIA (PAT)

Paroxysmal atrial tachycardia (PAT), the most common among the tachyarrhythmia, is characterized by paroxysms of very rapid heart rate, varying from 180 to 300 per minute or even more.

Etiology

The underlying cause is reentry within the A-V node. A premature atrial beat is conducted with delay through the node, initiating tachycardia.

The paroxysm may be precipitated by an acute infection or nervous or physical factors. Occasionally, it may accompany a congenital heart lesion.

Clinical Features

A. Older children: Paroxysm has an abrupt onset, usually lasting a few hours with a variation of few seconds to several weeks. Usually, there is no complaint, except awareness of rapid heart rate. Very rapid and very prolonged attacks may be accompanied by precordial pain and CCF.

B. Infants: Tachycardia that persists during sleep and quiet periods plus signs of CCF sooner or later are the common manifestations. A paroxysm lasting for more than 6 to 24 hours may, in addition, be accompanied by slight cyanosis, restlessness, irritability and moribund condition. If PAT occurs during intrauterine life, hydrops fetalis may result.

Diagnosis

An ECG must be done to confirm the diagnosis. The findings include rapid rate, abnormal P waves and a normal QRS complex.

In 10% of the PAT cases, ECG may show a short P-R interval and slow upstroke (prolongation) of QRS complex, the delta wave. This is what is called *Wolff-Parkinson-White (WPW) syndrome*. Also called *pre-excitation syndrome*, its presence is an indication for excluding such underlying anomalies as cardiomyopathy, corrected TGV and Ebstein anomaly. Undoubtedly, it may be present in an otherwise normal heart.

Treatment

Subjects in whom PAT does not spontaneously regress may respond to vagal stimulation by a simple procedure like unilateral carotid sinus massage, straining, breath-holding, drinking ice water, Valsalva maneuver or adopting a particular position.

In an emergency situation, electrical cardioversion may be resorted to.

Drug therapy includes digoxin in digitalizing dose, diphenylhydantoin, quinidine sulfate, propranolol, phenylephrine, edrophonium, calcium channel blockers (verapamil, diltiazem). In case of PAT in infants, therapy needs to be maintained for 3 to 6 months even if a particular paroxysm has been controlled by vagal stimulation.

SICK SINUS SYNDROME (SSS)

Abnormalities in the sinus node and/or atrial conduction pathways, most commonly encountered following operative correction of CHD (particularly the Mustard operation for TGV), result in what is termed *sick-sinus syndrome*.

Manifestations are variable. Most patients are symptom free. In symptomatic subjects, manifestations include dizziness, syncope, (during spans of marked sinus slowing) and supraventricular tachycardia

alternating with bradycardia (*bradycardia-tachycardia syndrome*), leading to palpitations, exercise intolerance or dizziness.

Drug therapy is aimed at controlling tachyarrhythmia. This therapy with agents such as digoxin, propranolol, quinidine, or procainamide may be accompanied by symptomatic bradycardia. A demand for ventricular pacemaker is, therefore, mandatory along with drugs in the symptomatic subjects with SSS.

LONG QT SYNDROME

This rare syndrome is characterized by prolonged QT interval, syncopal attacks and a variety of neurologic manifestations including nerve deafness, left-sided hemiplegia, absence spells and seizure-like episodes. SIDS may occur.

The fundamental defect appears to be an imbalance in sympathetic innervation of the ventricular myocardium which predisposes it to paroxysmal ventricular tachycardia and fibrillation. Two forms of the syndrome are recognized:

1. *Congenital* which may be autosomal recessive as in Jervell-Lange-Nielsen syndrome, or autosomal dominant as in Romano-Ward syndrome.
2. *Acquired* which may be secondary to
 - Drugs: quinidine, procainamide, phenothiazines, tricyclic antidepressants
 - Electrolyte imbalance: hypokalemia, hypomagnesemia, hypocalcemia
 - Hypothermia
 - Cerebrovascular disease
 - Neck surgery

Therapeutic measures include propranolol, diphenylhydantoin and left stellate ganglionectomy.

Mortality in untreated cases is very high—around 73%. With timely treatment, it is only 6%.

TAKAYASU ARTERITIS (*Pulseless Disease*)

This condition of inflammatory panarteritis of aorta and its major branches may occasionally be encountered in later childhood and infants.

Manifestations include obscure hypertension (due to renal ischemia), neurological disturbances (due to reduced blood flow) and visual disturbances. Pulses in the upper limbs are weak or even absent. Blood pressure in the legs exceeds that in the arms (just the reverse of coarctation of the aorta).

Accompanying or preceding features may include pyrexia, arthritis, myalgia, rash, pericarditis and pleuritis.

Laboratory findings may include high ESR, raised gammaglobulins, and positive LE preparation. Angiography, showing aneurysmal dilatation of the involved arteries, confirms the diagnosis.

Therapeutic modalities include steroids and, if warranted, endarterectomy or nephrectomy.

CARDIOMYOPATHY

The term denotes a disease entity in which the presenting manifestations result exclusively or predominantly from dysfunction of the myocardium.

The dysfunction can be secondary to such generalized diseases as hypertension, amyloidosis, hemochromatosis, SLE, leukemia, muscular dystrophy, glycogenosis or gargoylism. However, the term is, by convention, restricted to primary myocardial involvement without any known cause.

Clinical Categories

- A. *Congestive*, characterized by CCF, arrhythmias, murmurs of mitral and tricuspid incompetence and emboli.
- B. *Restrictive*, characterized by restriction to ventricular filling, and
- C. *Obstructive*, characterized by obstruction to ventricular outflow.

This division is, however, somewhat arbitrary. As is well-known, a given category may present some features of others, either at the same time or after a course of time.

Congestive cardiomyopathy: Endocardial fibroelastosis and endomyocardial fibrosis are the ones seen in pediatric practice.

Endocardial fibroelastosis is a relatively common cause of CCF in infancy. It is characterized by thickening of the endocardium of left ventricle in particular. Mitral incompetence is frequently associated.

X-ray chest shows cardiomegaly involving mainly the left ventricle and atrium.

ECG shows cardiomegaly involving mainly the left ventricle and atrium, conduction disturbances and arrhythmias.

Systemic embolization may follow mural thrombi which are quite common in this disease. Therapy is directed at controlling the CCF. Prognosis is bad.

Endomyocardial fibrosis is characterized by occurrence of fibrosis in the inflow tract and the apex of one or both ventricles.

The signs and symptoms depend on whether the right side chambers or left side chambers of the heart are involved.

X-ray chest shows cardiomegaly; intramyocardial calcium deposits may be visualized. ECG usually shows low voltage.

Restrictive cardiomyopathy: The patient with restrictive cardiomyopathy is generally in CCF with dependent edema, ascites and an enlarged, tender liver. The JVP is persistently elevated. Cardiomegaly is invariably present. The heart sounds are distant. Usually, third and fourth heart sounds are audible. Murmurs are, as a rule, not distinctive.

X-ray chest shows cardiomegaly without any calcification in the region of pericardium.

ECG shows low voltage. Arrhythmias and ST-T wave changes are common.

This kind of cardiomyopathy is difficult to be differentiated from constrictive pericarditis even with the aid of cardiac catheterization.

Obstructive cardiomyopathy: The *idiopathic hypertrophic subaortic stenosis (IHSS)* is characterized by enormous hypertrophy of the left ventricle, most remarkably in the interventricular septum.

What is striking in IHSS is that the obstruction to outflow is dynamic, changing every few minutes. This is in marked contrast to the fixed narrow orifice in the case of valvular aortic stenosis.

The disease is familial in 33% of the cases, though most often it does not manifest at birth or early in life.

PERICARDITIS

Pericarditis means inflammatory or noninflammatory involvement of the pericardium, leading to accumulation of varying amounts and nature of fluid in the pericardial cavity. As much as 1,000 ml of fluid (serous, purulent or hemorrhagic) may collect in the sac against the normal of 10 to 15 ml.

With rapid rise in amount of fluid and, consequent upon that, the pressure, there may result cardiac compression (cardiac tamponade). The compromised cardiac output may cause shock.

Etiology

Table 22.14 lists the causes of pericarditis.

Table 22.14: Causes of pericarditis

Bacterial	
• Purulent (pneumonia, osteomyelitis, meningitis, epiglottitis)	
• Tuberculous	
Viral	
• Coxsackievirus B	• Echovirus
• Epstein-Barr virus	
• Influenza	• Adenovirus
Fungal	
• Histoplasmosis	
• Actinomycosis	
Parasitic	
• <i>E. histolytica</i>	
• <i>Toxoplasma gondii</i>	
Collagen Disorders	
• Rheumatic fever	
• Rheumatoid arthritis	
• SLE	
Neoplastic Disease	
• Primary and metastatic malignancy	
Hematologic Disorders	
• Thalassemia	
• Leukemias	
Metabolic/Endocrinal	
• Uremia	
• Hypothyroidism	
Miscellaneous	
• Radiation injury	
• Trauma	
• Chronic constrictive pericarditis	

Clinical Features

These include precordial pain (presumably referred from pleural and diaphragmatic irritation), cough, fever and dyspnea on top of manifestations of the primary disease, say malnutrition in tuberculosis, joint pains/swelling in rheumatic fever or rheumatoid arthritis, URI in viral etiology, or significant anemia, generalized lymphadenopathy and bleeding in leukemias, etc.

Physical examination reveals increased cardiac dullness, a quiet heart, distant heart sounds (muffling), pericardial friction rub (only when

effusion is reduced), distended neck veins, pulsus paradoxus (10 to 20 mmHg inspiratory drop; over 20 mm Hg drop confirms presence of tamponade).

Onset of constrictive pericarditis is usually insidious and is marked by development of massive hepatomegaly and ascites, (suggesting chronic liver disease), distention of neck veins, and pulsus paradoxus*.

In well-established constrictive pericarditis, an early pericardial knock is an important finding.

Diagnosis

X-ray chest shows cardiomegaly with the so-called “water-bottle” configuration in which blunting of the cardiophrenic angles is characteristic (Fig. 22.25). Detection of calcification points to constrictive pericarditis.

ECG findings include low voltage of the QRS complexes, mild elevation of ST segment, and generalized T wave inversion, on top of the findings of the underlying disease.

Echocardiography is helpful for assessing the size and progression of effusion.

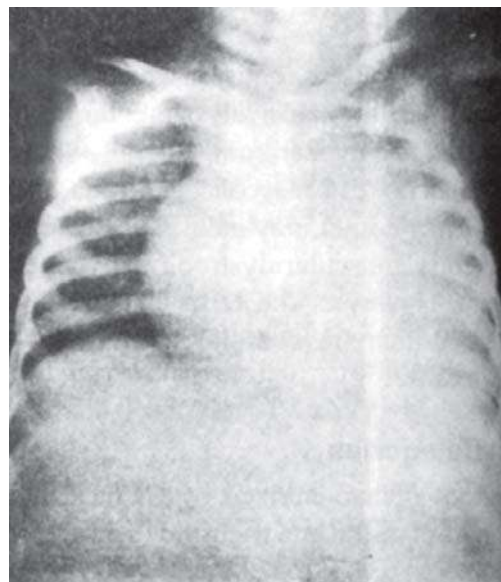

Fig. 22.25: Pericardial effusion. Note the cardiomegaly with blunting of the cardiophrenic angle, the so-called “water-bottle” configuration

* Remaining causes of pulsus paradoxus are conditions with gross dyspnea, say bronchial asthma, emphysema etc., cardiomyopathy and postthoractomy state

Pericardial puncture or tap (pericardiocentesis), described elsewhere (Chapter 43), is of help in confirming the presence of effusion and whether it is serous, purulent or hemorrhagic.

Treatment

Specific measures, including chemotherapy depend on the etiologic diagnosis.

Steroids are indicated in pericarditis accompanying rheumatic fever, tuberculosis and collagenosis.

Aspiration of pericardial effusion in case of pericardial tamponade (upto 200 ml at a sitting), under monitoring by ECG, can be life-saving.

Remaining measures include bedrest, oxygen inhalation, antipyretics, correction of anemia and maintenance of fluid and electrolyte balance as well as nutrition.

Decongestive therapy with digoxin for CCF accompanying pericarditis is best avoided.

Surgical intervention (radical pericardiectomy with decortication of pericardium) leads to gratifying response in constrictive pericarditis.

DEXTROCARDIA

The term refers to the presence of the heart in the right hemithorax with its apex pointing to the right.

Dextrocardia with situs inversus (Fig. 22.26) is the most common type. Here the position of the thoracic and abdominal viscera is also reversed. Since, there is transposition of all the organs to opposite side, cardiac hemodynamics remains normal. In an individual with this condition, the physician can find the normal liver on left side. Incidence of cardiac defects is low. Association of situs inversus with chronic bronchitis (sometimes with bronchiectasis) and chronic sinusitis (usually with otitis media) is termed *Kartagener syndrome*, *immotile cilia syndrome* or *dyskinetic cilia syndrome*. Differential diagnosis is from conditions that push or pull the heart to the right hemithorax. To confirm diagnosis, screening and X-ray chest are of value. Barium meal studies reveal a gastric gas bubble on right, confirming that the stomach is under the right diaphragm. ECG shows that, in lead 1, P and T waves are inverted; in aVR, these waves are upright.

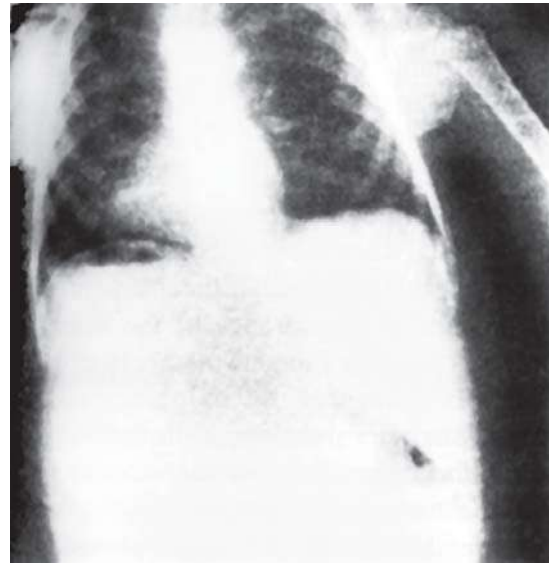

Fig. 22.26: Dextrocardia with situs inversus

Isolated dextrocardia (without situs inversus) is a serious condition, nearly always killing the patient in infancy or preschool years. The bad prognosis is chiefly due to the associated congenital heart disease. Tricuspid atresia, single ventricle, transposition of great vessels and tetralogy of Fallot rank prominently among the congenital cardiac associations reported so far.

Levocardia with situs inversus is another serious condition that usually kills the patient during early years. Here, position of the heart is normal. The abdominal organs are, however, on the opposite side, totally or partially. A variety of splenic anomalies have been described in association with levocardia. These include absence of spleen (asplenia) or rudimentary spleen. The presence of precipitated hemoglobin (Heinz bodies) or nuclear remnants (Howell-Jolly bodies) in the RBC should arouse suspicion of splenic abnormality. The various cardiac defects reported are: a single ventricle, atrioventricular canal, pulmonary stenosis, transposition of the great vessels and anomalous systemic and pulmonary venous return.

MYOCARDITIS

A large number of conditions (Table 22.15) may be responsible for myocardial damage in the form of myocarditis.

Table 22.15: Causes of myocarditis

Table 22.15: Causes of myocarditis	
<i>Viral Infections</i>	<i>Metabolic and Nutritional Diseases</i>
Coxsackie virus A and B	Beriberi
Rubella	Iron deficiency
Varicella	Kwashiorkor
Influenza	
<i>Bacterial Infections</i>	<i>Neuromuscular Diseases</i>
Diphtheria	Friedreich ataxia
Enteric fever	Progressive muscular dystrophy
<i>Parasitic Infections</i>	<i>Blood Disorders</i>
Toxoplasmosis	Anemia from any cause
Trichinosis	
Hydatid disease	<i>Inborn Errors of Metabolism</i>
Schistosomiasis	Glycogen storage disease
Trypanosomiasis (Chaga's disease)	(Type 2 or Pompe disease)
	Gorgoylism
<i>Fungal Infections</i>	<i>Coronary Arteries Damage</i>
Histoplasmosis	Kawasaki disease
Coccidiomycosis	
Actinomycosis	
Rickettsial Infections	Cardiotoxicity
Rocky Mountain spotted fever	Adriamycin
<i>Mesenchymal Disease</i>	Cyclophosphamide
Rheumatic carditis	Chloroquine
Rheumatoid arthritis	Iron overload
SLE	Chloramphenicol
Periarthritis nodosa	Alcohol
Dermatomyositis	Irradiation
Scleroderma	Ipecac

Viral myocarditis is, however, considered to be the commonest. The causative agents include Coxsackie virus A and B, ECHO, rubella, varicella and influenza infections.

Onset of symptoms is usually abrupt, especially in the neonates, with unexplained dyspnea, cardiovascular collapse and CCF. In older children, onset is usually gradual with CCF which may, at times, become chronic. Arrhythmias and conduction disturbances are frequent.

X-ray chest shows cardiomegaly with pulmonary venous hypertension.

ECG shows low voltage and nonspecific ST-T abnormalities.

Treatment consists in giving bed rest and digoxin (only half to 3/4th of standard dose). Steroids are usually recommended, especially when cardio-

vascular collapse and conduction disturbances are present.

SYSTEMIC HYPERTENSION

Hypertension is defined as the blood pressure of 95th percentile or more with reference to the age and sex. Normal blood pressure in children is related to the age and sex and hence one has to refer to the normograms charts for normal blood pressure values (Table 22.16). Blood pressure measurement upto 90th percentile is considered normal, though one has to watch for hypertension when the blood pressure is persistently about 90th percentile. Between 90th–95th percentiles it is labeled as borderline high blood pressure.

Blood Pressure Measurement in Children

An accurate measurement of blood pressure is important and it requires due attention to the comfort of the child, proper skills and techniques of blood pressure measurement. For correct measurement of blood pressure selection of appropriate sized cuffs are important in children. The age appropriate cuff sizes are, infants— 2.5 cm, 1-12 months – 5 cm, 1-8 years— 9 cm and older children 12.5 cms. Systolic pressure is indicated by appearance of Korotkov sound and the diastolic pressure is ideally noted when

Table 22.16: Normal blood pressure

Age	Normal Blood Pressure (mmHg)			
	Mean + 2 SD	Systolic	Mean + 2 SD	Diastolic
1 month	80 +	16	46 +	16
6 to 12 months	89 +	29	60 +	10
1 year	96 +	30	66 +	25
2 years	99 +	25	64 +	25
3 years	100 +	25	67 +	23
4 years	99 +	20	65 +	20
5 to 6 years	94 +	14	55 +	9
6 to 7 years	100 +	15	58 +	8
7 to 8 years	102 +	15	56 +	8
8 to 9 years	105 +	16	57 +	9
9 to 10 years	107 +	16	57 +	9
10 to 11 years	111 +	17	58 +	10
11 to 12 years	113 +	18	59 +	10
12 to 13 years	115 +	19	59 +	10
13 to 14 years	118 +	19	60 +	10

the sounds are muffled. However, if it is not possible to appreciate the change in the intensity of the sounds, disappearance of the sounds may be recorded as diastolic blood pressure. In children blood pressure is measured by palpatory method (the appearance of radial pulsation while deflating the cuff is systolic blood pressure) and auscultatory method. In infants, the methods are flush method, oscillometry and Doppler methods. Box 22.5 shows procedure of flush method of blood pressure recording in infants.

Box 22.5: Flush method of recording blood pressure in infants

To start with, the infant must be quiet and comfortable. You may give him a pacifier or a feeder.

Then the cuff (2.5-3 cm size so that it covers the 2/3 rd of the limb) is applied. It is, however, not inflated. An elastic crape bandage or a rubber band, about 2.5 cm wide, is applied round the forearm distal to the cuff.

Now the cuff is inflated to around 200 mm Hg. At this stage the crape bandage or band is speedily removed. As the cuff is gradually deflated a flush appears in the forearm. At this point, the pressure is noted. This is the mean blood pressure of the infant.

It must be borne in mind that for the next 15 minutes you cannot repeat the method.

Electronic transducer (ultrasound) and oscillometry are far more sophisticated facilities.

Etiology

In children, the hypertension is due to secondary causes in over 90% of case. Among them renal causes account for about 75% of cases. The essential hypertension, hypertension without any known underlying disease, accounts for only 5-10% of cases

in children. However, these patients will have family history, obesity, excess salt intake, stress and other reasons. Most often essential hypertension is recognized in adolescents. Secondary hypertension in children includes the causes of both transient and chronic hypertension. Most importantly, the cause of hypertension varies with age. The major causes of hypertension in children are of renal origin. Tables 22.17 and 22.18 list the causes of hypertension in children.

Clinical Features

Clinical features of hypertension depend upon the underlying cause and severity of hypertension. Most of the patients with mild hypertension and borderline hypertension and adolescents with essential hypertension may remain asymptomatic and hypertension is recognized during routine medical examinations. Especially in essential hypertension, the blood pressure is only slightly elevated with diastolic pressure at or slightly above the 95th percentile for the age. The symptoms attributed to hypertension are headache nausea, vomiting, dizziness and irritability. With severe hypertension, patient may develop hypertension crisis and hypertensive encephalopathy. Patients may have convulsions, altered sensorium, visual disturbances, persistent vomiting, cranial nerve palsies and other neurological deficits. Congestive cardiac failure though uncommon in children, can develop. More than the symptoms of hypertension, the clinical features of secondary causes of hypertension are common in children and they help in proper diagnosis. Renal disorders obviously

Table 22.17: Causes of transient hypertension in children

<i>Common causes</i>	<i>Others</i>
<ul style="list-style-type: none"> Acute post streptococcal glomerulonephritis Hemolytic uremic syndrome Anaphylactoid purpura Post renal transplant/urological surgery Hypervolemia 	<ul style="list-style-type: none"> Increased intracranial pressure Guillain–Barré syndrome Poliomyelitis Hypernatremia Corticosteroids/contraceptive administration Familial dysautonomia Postcoarctation repair
Renal trauma	

Table 22.18: Causes of chronic hypertension in children*Renal*

Chronic glomerulonephritis
 Chronic pyelonephritis.
 Hydronephrosis.
 Vesicoureteral reflux nephropathy
 Malformations of kidney (Dysplastic, Polycystic, Segmental hypoplasia, multicystic kidney)
 Renal tumors

Vascular/renovascular

Coarctation of aorta
 Umbilical artery catheterization
 Renal artery stenosis
 Renal Vein thrombosis
 Renal arteritis with or without aortitis

Endocrine disorders

Congenital adrenal hyperplasia (11B-hydroxylase and 17 hydroxylase defect)
 Cushing syndrome
 Pheochromocytoma
 Neuroblastoma
 Primary aldosteronism

Other causes

Intracranial mass
 Hemorrhage
 Essential hypertension

4

present with renal symptoms like polyuria, edema, decreased urine output, etc. Patients with pheochromocytoma present with episodes of palpitation, sweating and flushing. Obesity, buffalo hump, hirsutism and abdominal striae are features of Cushing syndrome. Similarly, features of other diseases may be present. Hypertensive retinopathy will show specific changes.

Clinically it is useful to separate mild (grades I and II) from severe retinopathy (grades III and IV) as well as prognosis are different for these categories. The presence of exudates and hemorrhages significantly influence the improvement.

- Grade 1 : Copper-wire appearance of arterioles which assume shape of broad yellow lines
 Grade 2 : Thickened arterioles without visible blood column nip the veins.
 Grade 3 : Hemorrhages and exudates
 Considerable narrowed arterioles, with a diameter, which is only $\frac{1}{4}$, th of that

of veins, appear as broad white silver lines. Blood column is not visible. Dilatation of vein distal to the artery is apparent.

- Grade 4 : Papilledema on top of changes seen in Grade 3 retinopathy.

Diagnosis

The first and foremost thing in the diagnosis of hypertension is proper recording of the blood pressure. Several recordings are important before labeling a child as suffering from hypertension. Appropriate sized cuffs, appropriate method of recording, and comfortness of the child during blood pressure recording are important.

Mild blood pressure and borderline elevation requires close follow-up and repeated measurements. Other associated features helps in finding the etiology. Only after confirming hypertension, investigations should be planned. No need to do battery of investigations in all children. Start with investigation for commoner cause and consider advanced investigations later to confirm the diagnosis. The investigations for hypertension include hemogram, urine analysis, urinary electrolytes, blood urea, nitrogen, serum Creatinine, chest X-ray echocardi-ography, electrocardiography, renal imaging studies, urinary catecholamines, angiography, renal biopsy, plasma renin activity, renal scintiscan, etc.

Urine analysis: One of the most important screening test and should be done in all cases. Proteinuria, hyaline and granular casts characterize chronic glomerulonephritis. Leucocytes and granular casts indicate pyelonephritis. Hematuria, beside glomerulonephritis, is indicative of many other renal disorders. 24 hours urinary protein analysis may be required.

Urine culture: As urinary tract infection, either isolated or in association with reflux or obstructive nephropathy is the important cause of hypertension, urine culture should be considered in all cases.

Hemogram: Required as a supportive investigation for the diagnosis of pyelonephritis, hemolytic uremic syndrome, etc.

Renal function tests: Raised blood urea and creatinine are observed in renal disorders. Decreased Creatinine clearance suggests diminished glomerular filtration.

Serum electrolytes: Abnormalities in electrolytes are observed in disorders like renal and endocrine causes.

Urinary electrolyte: Helps in diagnosing renal disease including renal tubular disorders.

Plasma renin activity: Increased plasma renin suggests renal or renovascular disorder.

Urinary catecholamines: They are elevated in pheochromocytoma

Chest X-ray: Useful in the diagnosis of cardiovascular causes like coarctation of aorta. Similarly electrocardiography and echocardiography help in identifying coarctation of aorta and helpful in assessing cardiac response to the elevated blood pressure

Renal ultrasonography is a useful noninvasive tool. It helps in evaluating renal parenchyma, diagnosis of hydronephrosis, renal mass and suprarenal masses.

Renal radionuclide scan: It helps in distinguishing variations in renal perfusion.

Renogram: Rate of uptake and disappearance of I132 labeled hippuran helps in identification of renovascular disorders.

Renal angiography: It demonstrates lesions in the main arteries or the segmental branches. Doppler ultrasonography may demonstrate arterial and venous blood flow.

Other tests may be done as required.

Management

Every effort should be made to make a proper diagnosis to optimize the therapy. The treatment of hypertension includes both nonpharmacological and pharmacological treatments. Nonpharmacological treatment includes salt restriction, diet modification, exercise, avoidance of smoking (in adolescents) and control of stress and anxiety. Salt restriction is not practical in younger children. Adolescents with essential hypertension should be counseled about smoking, beside other measures. Dietary modifications and exercise are important in obese children.

Pharmacological Therapy

Patients with persistent hypertension require drugs to control hypertension. Selection of proper drug and appropriate combinations are important for better results. An understanding of the pathology is useful in selecting the drug. Drugs acting at different level with different mechanisms of actions have to be combined for better results, especially when long term drug therapy is required. Various drugs used in the treatment of hypertension include, diuretics, vasodilators, angiotensin converting enzyme inhibitors, centrally acting sympatholytic agents, calcium channel blockers and adrenergic drugs. The dosage schedule is summarized in Table 22.19.

Diuretics: Diuretics are an important group of drugs in the management of hypertension, especially in cases of hypertension due to renal disorders. Thiazide diuretics (hydrochlorothiazide, chlorthiazide) are commonly used. They cause hypokalemia, some time

4

Table 22.19: Antihypertensive drugs

Diuretics

Hydrochlorothiazide: 1 mg/kg/dose/day at OD or BD
Frusemide: 1-2 mg/kg/day BD (PO/IV)

ACE inhibitors

Captopril: 0.1-0.3 mg/kg/dose (max-2mg/kg/dose), PO, 8hrly.
Enalapril: 0.01 mg/kg/dose PO, BD

Vasodilators

Hydralazine: 0.4-0.8 mg/kg/dose (IV) 2-4 hrly
0.5-2.0 mg/kg (Max 200 mg/day) PO 6-8 hrly.
Diazoxide : 2.5 mg/kg/dose (max 100 mg), IV 6- 24 hrly.
Sodium nitropruside: 0.5-8.0 mg/kg/min IV infusion. Titrate as required.
Minoxidil: 0.2-1.0 mg/kg/day (Max 50 mg/day), PO OD or BD

Adrenergic blockade agents

Propranolol: 0.25-1.0 mg/kg/dose, PO, 6-8 hrly.
Labetolol: 5-10 mg/day, BD
0.2 mg/kg/hr infusion for hypertensive crisis

Sympatholytic drugs

L-methyldopa: 10-40 mg/kg/day BD
Clonidine: 3.5 mg/kg/dose, TID

Calcium channel blockers

Nifedipine: 0.2-0.5 mg/kg/dose (max 10-20mg), PO
300-500 mg/kg/dose – sublingually
Verapamil: 0.15 mg/kg bolus dose followed by 5 µg/kg/min infusion.

hyperuricemia and require potassium supplementation. Frusemide is less effective than thiazides and causes profound hypokalemia. Spironolactone is useful in hypertension secondary to adrenal adenoma.

Vasodilators and angiotensin converting enzyme inhibitors (ACE inhibitors): Vasodilators helps in reducing hypertension by reducing afterload. ACE inhibitors are very useful in conditions with excess renin activity. ACE inhibitors can cause cough, rash, neutropenia, proteinuria and hypotension, Captopril, is the most commonly used drug. However, enalapril is more potent and has less adverse effects. ACE inhibitors are more effective when used in combination with diuretics. Hydralazine can cause tachycardia, drug induced lupus erythematosus. Minoxidil is associated with hirsutism and fluid retention.

4 *Calcium channel blockers:* Calcium channel blockers cause vasodilatation and increase the excretion of sodium. They can cause facial flushing, tachycardia, and hypotension.

Sympatholytic agents: Alpha methyl dopa and clonidine are centrally acting antihypertensive agents. They can cause sedation (methyl dopa), lupus like syndrome, hepatitis and postural hypotension. They are a useful group of drugs in the management of hypertension.

Hypertensive crisis: Admit the patient in pediatric intensive care unit. Stabilize airway, breathing and circulation, if required. Select appropriate anticonvulsants. The drugs of choice are intravenous labetalol, sodium nitropruside or sublingual nifedipine. Start with intravenous labetalol or sodium nitropruside infusion and titrate the rate of infusion depending upon the response. While patient is on high dose infusion, sudden profound hypotension can develop and hence very close monitoring and titration of the drug is required. In the event of hypotension, stop the infusion and then decide depending upon the blood pressure levels whether to continue or not and also consider using alternative drugs. Sublingual nifedipine has very short duration of action not an ideal drug in hypertensive crisis. However, while arranging for labetalol or sodium nitropruside or other drugs and when other drugs are not available nifedipine can be tried.

Alternatively, intravenous hydralazine or diazoxide may be used. Once the blood pressure levels are reduced and remain stable for some time, start on oral antihypertensive drugs and withdraw parenteral drugs. Hypertensive crisis due to pheochromocytoma requires use of alpha adrenergic blocking agents like phentolamine (1-2 mg IV and effect starts in about a minute). Propranolol should be added only after starting alpha adrenergic blockers. Otherwise it causes rebound hypertension.

Course and Prognosis

Poorly controlled hypertension will predispose many hypertension related problems like stroke, Ischemic heart disease etc. Adolescents detected to have essential hypertension will probably continue to have hypertension as adults. In cases of secondary hypertension, the prognosis is dependent on the underlying course and its natural course. The prognosis of surgically connected coarctation is variable. The prognosis in cases of chronic renal disease depends upon the response to dialysis and transplant. Neonates who develop hypertension due

Table 22.20: Indications of various interventional cardiac procedures

Procedure	Indications
Balloon valvuloplasty	<i>Stenotic valves:</i> Aortic stenosis, mitral stenosis <i>Narrow arteries:</i> Coarctation of aorta, obstructive aorto-arteritis <i>Venous obstruction:</i> Superior/inferior vena cava obstruction
Closing of abnormal openings	VSD, ASD
Closing of arterial channels	PDA, aortopulmonary collaterals in TOF, surgically created shunts in Fallot's physiology, coronary arteriovenous fistula, systemic arteriovenous fistula, pulmonary arteriovenous fistula
Radio frequency ablation techniques	Arrhythmia management

to umbilical artery catheterization have favourable outcome with most of them improving.

Prevention

Essential hypertension can be prevented with changes in the life style including food modifications, exercise restricting high salt intake, avoidance of smoking and alcohol in adolescents. The prevention of secondary hypertension requires primary prevention mainly and appropriate secondary preventive measures.

INTERVENTIONAL CARDIAC PROCEDURES

As a result of availability of interventional cardiac procedures, outlook for several congenital heart defects has improved considerably. The indications for various interventional procedures are summarised in Table 22.20.

An interventional cardiac procedure has got to be performed in consultation with a cardiac surgeon.

BIBLIOGRAPHY

Articles/Chapters

1. Bernstein D. The cardiovascular system. In: Behrman RE, Kliegman RM, Jenson HB (Eds) *Nelson Textbook of Pediatrics*, 17th edn. Philadelphia: Saunders, 2004:1337.
2. Driscoll DJ. Evaluation of the cyanotic newborn. *Pediatr Clin North Am* 1990;37:1.
3. Doniger SJ, Shariieff GQ. Pediatric dysrhythmias. *Pediatr Clin North Am* 2006;53:85.
4. Garekar S, Humes RA. Cardiac interventions and surgeries for congenital heart disease in the neonatal period. *Pediatr Today* 2005;7:353-361.
5. Kumar K. Neurological complications of congenital heart disease. *Indian J Pediatr* 2000;67:287.
6. Maiya PP, Karunakara BP. Congestive cardiac failure. In Gupte S (Ed): *Recent Advances in Pediatrics (Special Vol 14: Criticare Pediatrics)* New Delhi: Jaypee 2004:328.
7. Saxena A. Diagnosis of rheumatic fever: Current status of Jones criteria and role of echocardiography. *Indian J Pediatr* 2000;67:283.

Book/Monograph

1. Gupte S, Saxena A. *Recent Advances in Pediatrics (Special Vol : Pediatric Cardiology)*. New Delhi: Jaypee 2006.

CHAPTER



23

Pediatric Neurology

Suraj Gupte, Bhavana B Chowdhary

Neurologic disorders show a wider and more diverse spectrum in infancy and childhood than in adulthood. In addition, congenital neurologic disorders, residual birth injuries, birth asphyxia and CNS infections have special significance in pediatric practice.

DEVELOPMENTAL ASPECTS

At the very outset, it is of value to recall that development of the central nervous system (CNS) occurs in three stages. In the first stage, the so-called *cytogenesis*, the genetic and chromosomal disorders, malformations and inborn errors of metabolism express themselves. In the second stage, the so-called *histogenesis*, the disorders like agenesis of corpus callosum, tuberous sclerosis, etc., express themselves. In the third stage, the so-called *organogenesis*, is determined by the eventual shape of the CNS. Fault in blending of the neural and extraneural tissues results in arteriovenous malformations. When neural tissue develops a faulty blending with the ectodermal tissue, hamartoma, craniopharyngioma, etc. may occur. Porencephaly or hydranencephaly may follow destructive or inflammatory lesions of the brain.

NEUROLOGIC EVALUATION

Evaluation of CNS must begin with an *accurate history followed by examination* conducted with patience, tact and observations. Special attention must be paid to examination of head, cranial nerves, motor system, sensory system, gait and station. Also see Chapter 1.

The so-called *soft neurologic signs* deserve a special emphasis. These are defined as particular forms of deviant performance on a motor or sensory test in

the neurologic examination which is abnormal for a particular age. Table 23.1 provides the list of soft neurologic signs. One must exercise significant caution in testing the presence of these signs. It may mean observation of a series of timed motor tasks as also comparison of the patient's movements with those of normal children of similar age and sex.

Table 23.1: Soft neurologic signs

- Mirror movements
- Head bobbing/foot tapping
- Dysdiadochokinesia
- Finger agnosia
- Stimulus extinction
- Choreiform movements
- Lateral dominance
- Verbal dyspraxia
- Strabismus

The interpretation of a soft neurologic sign is also problematic. It may well be present in an intellectually normal child. Yet, presence of two or more such signs in a child points to a neurologic dysfunction in the form of behaviour, coordination and learning difficulties

According to one school of thought, NSSs represent a developmental lag rather than a fixed neurological abnormality (the earlier view). Such a dysfunction could well be cerebral palsy or simply an attention deficit or learning disorder. Therefore, rather than jumping at giving the child a label of a development disability, the child should be monitored closely.

The cornerstone of a neurological examination is localization of the lesion. Unfortunately, NSSs fail to help us here. On the other hand hard signs (tendon reflexes, MacWen's sign) decidedly do so!

Neurologic investigations include:

1. *Lumbar puncture* and CSF examination are mandatory for confirming the diagnosis of meningitis, encephalitis and subarachnoid hemorrhage. These also assist in the evaluation of the demyelinating, degenerative and collagen vascular disorders and the presence of tumor cells. Also see Chapter 43.
2. *Subdural tap* is indicated for confirming the diagnosis of subdural effusion or hematoma.
3. *Ventricular tap* is indicated for removal of CSF in life-threatening raised intracranial pressure provided that the conservative measures to reduce it have failed.
4. *Skull X-ray* is a useful procedure for demonstrating skull fracture, intracranial calcification, craniosynostosis, bony defects, congenital anomalies or raised intracranial pressure.
5. *Cranial ultrasound* is of value in the infants with a patent anterior fontanel in delineating hemorrhage, hydrocephalus, and tumor. In older children, it may be employed for placement of a shunt, location of a small tumor and for direction of needle biopsy.
6. *Computed tomography (CT scanning)*, a noninvasive procedure that makes use of conventional X-ray techniques, has revolutionized the neurologic evaluation. It is of special value in demonstrating congenital anomalies (poroencephalic cysts, hydrocephalus), subdural collection, calcification, hematoma, tumor, and areas of cerebral edema, infarction and demyelination. CT scanning is not quite useful in delineating lesion of posterior fossa and spinal cord.
7. *Magnetic resonance imaging (MRI)*, another noninvasive procedure that does not utilize ionizing radiation (hence totally free of biologic risk), is of special value in delineating neoplasm, cerebral edema, degenerative diseases and congenital anomalies. Unlike CT scanning, it is capable of delineating lesions of posterior fossa and spinal cord. It cannot detect intracerebral calcification.
8. *Functional scans*, say positional omission tomography (PET) and SPECT are important presurgical investigations in intractable epilepsy, cerebral tumors and head injury.
9. *Cerebral angiography*, using digital subtraction technique, is especially of value in delineating arteriovenous malformations, aneurysms, arterial occlusions and venous thrombosis.
10. *Pneumoencephalography* is of value in delineating prepontine and chiasmatic cisterns.
11. *Myelography* is useful in demonstrating spinal cord compression, e.g. congenital anomalies, tumors, vascular malformations, etc. The procedure requires injection of contrast material into the subarachnoid space, resulting in arachnoiditis at times. Currently, MRI is believed to be superior to contrast myelography in a majority of the situations.
12. *Electroencephalography (EEG)* is of value in evaluation of paroxysmal neurologic disorders, say epilepsy. The EEG waves may be graded as delta (1 to 3 per sec), theta (4 to 7 per sec), alpha (8 to 12 per sec), and beta (13 to 20 per sec). Many factors like age, state of alertness/wakefulness, eye closure, medication and disease tend to cause alteration in these waves. Spikes and slow waves are usually indicative of epilepsy. Focal spikes may be manifestation of irritative lesions, say cysts, slow-growing tumors and glial scar tissue. Slow focal waves may point to existence of a circumscribed lesion, say a hematoma, tumor, infarction or localized infectious process. A metabolic, inflammatory or more widespread process causes generalized slow waves. Its limitations include normal records in interictal periods, abnormal record even in some normal individuals and inability to assist in decision-making on stopping anticonvulsant therapy.
13. *EEG/polygraphic/video monitoring* is of great help in precise delineation of types of seizures and thus exact medical or surgical management, in differentiating epilepsy from epilepsy-like states, for study of efficacy of various therapeutic measures, and characterization of seizures in neonates.
14. *Evoked potentials*, an electrical response that follows stimulation of CNS by specific stimulus of the visual, auditory or sensory system, is beginning to find increasing application. Visual evoked potentials (VEPs), brainstem auditory

evoked potentials (BAEPs), and somatosensory evoked potentials (SSEPs) can detect visual, auditory and spinal cord functions in neonates, in comatosed individuals and during operative procedures.

15. *Biopsy* of such tissues as nerve, ganglion cells of rectum, or brain may be useful in metabolic and degenerative disorders.
16. *Psychometric tests* are useful for evaluating the cognitive ability and intelligence of a suspected case of mental retardation.
17. *Electroretinography* is useful in evaluation of degenerative disorders of retina.
18. *Electromyography* is useful in evaluation of neuromuscular disorders. It is of particular help in characterization of muscle disorders. In a floppy infant, it clarifies whether the cause is neurogenic or myogenic.
19. *Nerve conduction studies* are useful in evaluation of peripheral neuropathies (poliomyelitis vs Guillain-Barre syndrome) and degenerative disorders involving peripheral nervous system (metachromatic leukodystrophy).

NEURAL TUBE DEFECTS

(Myelodysplasia, Dysraphism)

Neural tube defects are responsible for an overwhelming number of developmental anomalies of the CNS. They result from a failure of the neural tube to close *in utero* between third and fourth week of gestation.

Risk of such defects is 1.5 m in 1,000 live births. Risk in subsequent pregnancies is as high as 50 in 10,000 live births.

Such factors as maternal radiation, drugs and chemicals, malnutrition and genetic determinates, alone or in one or the other combination, adversely affect the normal development of the neural tube, thereby causing the defect.

Types

Spina bifida occulta is the most frequent and the most benign neural tube defect. It is usually detected on an X-ray of the spine that reveals a defective closure of the posterior arch and laminae of the vertebrae, usually L5 and S1. Most of the cases are asymptomatic. In an occasional case, loss of bladder

and bowel control and cavus deformities of feet develop as the child grows. More significant anomalies of the spinal cord (say diastematomyelia, tethered cord, syringomyelia, etc.) may coexist with spina bifida occulta in a small proportion of the cases. Progressive neurologic abnormality is an indication for a surgical correction.

Meningocele is a fluctuant midline sac of meninges that herniates through a defect in the posterior vertebral arch, generally in the low back (Fig. 23.1). It transilluminates easily. Usually, it is asymptomatic and well covered with skin. Associated anomalies include hydrocephalus, diastematomyelia, tethered cord and liema. Surgery may be delayed unless there are neurologic symptoms, skin covering is thin, or CSF leak is present.

Meningomyelocele (myelomeningocele) is a midline cystic sac of meninges and spinal tissue that herniates through a defect in the posterior vertebral arch, usually in the lumbosacral region though it may be located any-where along the neuroaxis (Fig. 23.2). It transilluminates less easily, is covered with only a thin skin, and is usually accompanied by a neurologic deficit (say flaccid paralysis, absent drop reflexes and absent sensations) and such postural abnormalities as club foot and subluxation of the hips. In case of meningomyelocele of the thoracic or cervical region, neurologic signs are in the form of spasticity and hyperactive reflexes. Hydrocephalus is a common association. Risk of rupture of the sac with superadded infection and meningitis is high. It is a sound principle to aggressively repair the meningomyelocele followed by a shunting procedure if hydrocephalus coexists with it.



Fig. 23.1: Meningocele



Fig. 23.2: Meningomyelocele



Fig. 23.3: Encephalocele

Encephalocele (Fig. 23.3) is a meningeal sac together with cerebral cortex, cerebellum, or portions of the brainstem herniating through a bony defect in the skull (cranium bifidum), usually in the occipital region. The size may vary from small to as big as exceeds the cranium. There is high risk of developing hydrocephalus due to aqueduct stenosis or a Chiari malformation and Dandy-Walker syndrome. Association of occipital encephalocele with cleft lip or palate, microcephaly, abnormal genitalia, congenital nephrosis and polydactyly is termed *Meckel-Gruber syndrome*. Prognosis is poor. Most of the patients develop visual problems, seizures, mental retardation and microcephaly. Prenatal diagnosis is possible by estimation of alpha-fetoprotein level and biparietal diameter on ultrasonography.

Anencephaly is a rudimentary brain with a large defect of the calvarium, meninges and scalp. Folding of the ears, cleft palate and congenital heart disease co-exist in some 15% of the cases. In half of the anencephalic pregnancies, there is history of polyhydramnios. Death usually occurs within a week or two of birth.

Diastematomyelia is a projection of bony or fibrocartilaginous septum from the posterior vertebral body that divides the spinal cord into two halves. The commonest site is L1, L2 and L3. It is usually

accompanied by such abnormalities of the vertebral bodies as fusion defects, hemivertebrae, hypoplasia, kyphoscoliosis, spina bifida and meningomyelocele. The presence of a localized midline tuft of hair, dermal sinus, hemangioma, etc., should arouse suspicion of existence of this anomaly. In symptomatic cases, there is weakness and muscle atrophy in lower limbs and urinary incontinence. Excision of the bony spur and lysis of surrounding adhesions is indicated in symptomatic cases.

Tethered spinal cord refers to the persistence of conus medullaris as a thickened rope-like filum terminate at or beyond the L2 level (normally it ends at L1), producing neurologic signs sooner or later. A midline skin lesion like lipoma, tuft of hair, dermal pit, hemangioma or a hyperpigmentation patch may provide a clue to the presence of this anomaly. Association with diastematomyelia is well known. Frequently, talipes equinovarus accompanies it. Surgical excision of the terminate is warranted to halt the progression of the neurologic signs.

Syringomyelia is a cystic cavity within the spinal cord. It may communicate with the CSF pathway (syringobulbia). Communicating syringomyelia is usually complicated by Chiari type 1 malformation.

In it CSF passes caudally on sneezing or coughing, producing dilatation of the central canal. Noncommunicating syringomyelia is complicated by cord tumors, trauma, vascular accidents and arachnoiditis.

Syringomyelia progresses slowly, producing symptoms in later childhood or adulthood. Manifestations include a progressive scoliosis, dissociation of sensations (loss of pain and temperature, preservation of light touch), trophic ulcers, muscle wasting, absent deep reflexes in upper limbs and upper motor neuron signs in lower limbs.

Treatment includes decompression, plugging the open end of the central canal, percutaneous aspiration and draining the cystic cavity into subarachnoid space.

Lissencephaly (agyria) manifests with failure to thrive, microcephaly, gross developmental delay and seizures, often in association with ocular anomalies, distinctive facies with prominent occiput, broad forehead and anteverted nostrils. Remarkable absence of sulci and smooth brain are the noteworthy CT scan findings.

Schizencephaly denotes presence of clefts within the cerebral hemisphere which may be fused or unfused and unilateral or bilateral. Manifestations

include severe mental retardation, seizures, microcephaly and spastic quadriplegia. CT scan is diagnostic in delineating the size and shape of the cleft.

Porencephaly means presence of cavities or cysts (Fig. 23.4) within the brain in the region of Sylvian fissure. They communicate with subarachnoid space, the ventricular system, or both. Manifestations include microcephaly, mental retardation, seizures, quadriplegia and optic atrophy.

Agenesis of cranial nerves may include II, III, V, VIII, IX, X, XI and XII nerves. In the so-called *Mobius syndrome*, there is facial weakness (bilateral) and feeding difficulty presenting in neonatal period.

Agenesis of corpus callosum may be present as an inherited X-linked trait or as a component of a specific chromosomal disorder like trisomy 8 and trisomy 18.

Acardi syndrome, a rare disease of females, is characterized by a trio of infantile spasms, chorioretinopathy and agenesis of corpus callosum. Additional features include vertebral and costal anomalies (fusion of vertebral bodies, hemivertebrae, scoliosis, spina bifida, fused ribs) and subependymal heterotopies. Motor and mental retardation is apparent at early age. The cause appears to be a newly mutated X-chromosomal dominant gene lethal to males *in utero*. CT scan detects agenesis of corpus

callosum. Prognosis is poor, most patients dying early in life.

Prenatal Diagnosis

Prenatal screening of maternal serum for alpha-fetoprotein is currently the most effective method for identifying at-risk pregnancies in relation to neural tube defects *in utero*.

Prevention

Administration of periconceptional folic acid, 5 mg/day (Q) after the birth of a defective baby till 3 months after the next conception has a protective role against recurrence of NTD. Folic acid acts not by correcting the deficiency but by overcoming an enzymatic block (deficiency of enzyme *5-methyl tetrahydrofolate* because of partial block in conversion from 5, 20 *methylene tetrahydrofolate*) in homocysteine metabolism.

PSEUDOTUMOR CEREBRI (Benign Intracranial Hypertension, Otitic Hydrocephalus)

This condition is characterized by raised intracranial pressure without any biochemical or cellular CSF abnormalities and produces manifestations that simulate those of an intracranial space occupying lesion such as a brain tumor.

Clinical Features

Manifestations include bulging fontanel, papilledema, changes in sensorium, headache, convulsions, vomiting and other neurologic abnormalities like sixth nerve paralysis and ataxia. There is, as a rule, no evidence of focal neurologic deficit. If the high pressure continues, optic atrophy and blindness may follow.

Etiopathogenesis

Raised intracranial pressure results from diffuse cerebral edema. The pathogenesis is not clear. Various explanations include:

- Alterations in CSF absorption and production
- Cerebral edema
- Erroneous vasomotor control
- Erroneous cerebral blood flow
- Venous obstruction.

Various causes of pseudotumor cerebri are given in Table 23.2.



Fig. 23.4: CT scan demonstrating porencephalic cysts in left frontal region

Table 23.2: Etiology of pseudotumor cerebri

<i>Metabolic</i>	Galactosemia, hypoparathyroidism, pseudo-hypoparathyroidism, hypophosphatasia, prolonged steroid therapy, sudden withdrawal of steroid therapy, hypervitaminosis A, hypovitaminosis A, Addison disease, obesity, cystic fibrosis growth hormone therapy, menarche, contraceptives, pregnancy
<i>Infections</i>	Chronic otitis media, mastoiditis, roseola infantum, GBS
<i>Hematologic</i>	Iron-deficiency anemia (chlorosis), lead poisoning, hemolytic anemia, polycythemia, Wiskott-Aldrich syndrome
<i>Drugs</i>	Nalidixic acid, tetracyclines, nitrofurantoin, DPT vaccine
<i>Obstructive</i>	Lateral sinus thrombosis, posterior sagittal sinus thrombosis, obstruction of superior vena cava, head injury
<i>Collagenosis</i>	SLE
<i>Nutritional</i>	Overenthusiastic dietetic therapy in malnutrition

Treatment

Pseudotumor cerebri is a self-limiting condition. Raised intracranial pressure (RIP) may persist for several months. If RIP is of high magnitude, there is a risk of chronic compression causing optic nerve damage. Attempts to remove the supposedly offending factor and reduce intracranial pressure should be made in patients with grossly raised pressure. Repeated lumbar punctures, restriction of fluids, hypertonic solutions and diuretics (acetazolamide, 30 to 50 mg/kg/day) are justified. Some authorities recommend steroids and even surgical decompression by removing subtemporal bone flap. Obese children must reduce their weight.

ACUTE STROKE SYNDROMES

(Acute Hemiplegia of Childhood Acute Infantile Hemiplegia, Stroke)

It is defined as the occurrence of hemiplegia following arterial thrombosis/embolism, venous thrombosis, intracranial hemorrhage, etc.

Types

Arterial Thrombosis and Embolism

It follows involvement of major cerebral arteries (internal carotid, anterior, middle and posterior cerebral) or smaller cerebral arteries.

Blunt trauma to posterior pharynx, and acute angulation of the artery are important causes of internal carotid artery thrombosis followed by shedding of emboli from the thrombi.

Manifestation include a progressive flaccid hemiplegia, aphasia if dominant hemisphere is involved and focal motor seizures.

Venous Thrombosis

It may follow sepsis (meningitis, otitis media, cavernous sinus thrombosis) or nonseptic conditions (hypercoagulopathy, cyanotic congenital heart disease, iron-deficiency anemia, leukemia) and is characterized by dilated scalp veins, bulging anterior fontanel and manifestations of increased intracranial pressure (ICP).

Intracranial Hemorrhage

The underlying conditions are arteriovenous malformations and rarely cerebral aneurysms.

Subarachnoid hemorrhage is characterized by severe headache, neck rigidity and progressive deterioration in sensorium.

Intracerebral hemorrhage, usually seen in preterm infants, is characterized by focal neurologic signs and seizures.

Differential Diagnosis

It is from stroke-like events such as alternating hemiplegia of childhood, Todd paralysis, metabolic diseases (MELAS), cerebral tumors, encephalitis, lipid abnormalities, etc.

Diagnosis

If, despite good history and physical examination plus CT scan (Fig. 23.5) and/or MRI, cerebral angiogram, ECG, EEG, etiologic diagnosis remains unclear, basic investigation should be carried out to exclude:

- Vasculitis/connective tissue disorders
- Lipid disorders
- Coagulopathies
- Sickle-cell disease
- Thrombocytopenia
- Metabolic disorders (homocystinuria, MELAS)
- CNS infections (meningitis, encephalitis, etc.)

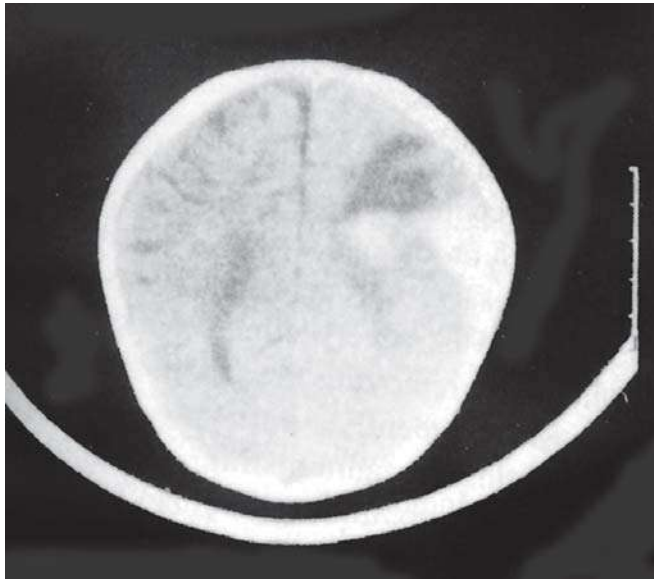

Fig. 23.5: CT scan showing intracerebral hemorrhage in a child with left-sided hemiplegia

4

Treatment

Supportive measures include attention to ABC, fluid management, maintenance of normoglycemia and control of fever and seizures.

Role of thrombolytic therapy (aspirin, heparin) in pediatric stroke remains unclear.

Rehabilitation revolves around multidisciplinary approach including speech, occupational and physiotherapy plus special education and psychologic services.

Prophylaxis against recurrence(s) includes:

- Heparin (low molecular weight) for several months
- Aspirin
- Regular blood transfusions in sickle-cell disease
- Immunosuppressant therapy in vasculitis.

BELL Palsy

This is an isolated acute unilateral 7th nerve palsy that develops about 2 weeks after a viral infection such as Epstein-Barr virus (commonest), herpes virus, mumps virus, or Lyme disease.

Manifestations include deviation of the upper and lower face to opposite side, drooping of the corner of the mouth, inability to close the eye, loss of taste on anterior 2/3rds of the tongue.

Over 85% cases show full recovery spontaneously. In 10% cases, the patient may be left with slight weakness. In the remaining 5% cases, permanent severe facial weakness may persist.

Treatment in acute cases is more or less supportive. An ocular lubricant, especially at night, is needed for protection of the cornea. In chronic cases (not recovering in few weeks), such causes of facial nerve involvement as leukemia, tumors, brainstem infarct and injury must be ruled out. Electrophysiologic examination of the facial nerve may help to find out the extent of neuropathy and degeneration.

GUILLAIN-BARRÉ SYNDROME

(Postinfectious Polyneuritis, Acute Inflammatory Demyelinating Polyradiculoneuropathy (AIDP), Infective Polyneuritis, Infectious Polyradiculitis)

The term is applied to a nonspecific viral infection/inflammatory disorder of peripheral nerves and nerve roots characterized by symmetrical muscle weakness, sluggish or absent tendon reflexes, paresthesia or other sensory disturbances and autonomic dysfunction.

Maximum cases are seen in the age group 5 to 12 years.

Etiopathogenesis

The condition has a definite relationship to such diseases as measles, chickenpox and rubella. Infectious mononucleosis (glandular fever), mumps, influenza and Coxsackie or ECHO infections have also been incriminated. What is important is that the polyneuritis usually starts after a substantial interval of about 10 days following the viral infection. Hence, the term "postinfectious" appears to be most appropriate.

The mechanism of causation too is not clear. It appears that breakdown of the nerve myelin occurs as an autoimmune process following the migration of the peripheral lymphocytes which have been sensitized to a protein component of the myelin. The myelin undergoes destruction as a result.

Clinical Features

The earliest manifestation is muscle pain followed by weakness in the proximal as well as distal group of muscles. Characteristically, muscle involvement is



Fig. 23.6: Guillain-Barré syndrome

symmetrical in distribution and not in extent (Fig. 23.6). It first begins in the lower limbs and then spreads to the trunk, upper limbs and face. Muscle tone is reduced, so are the tendon reflexes. Plantars are usually downgoing. Involvement of the intercostals may lead to respiratory difficulty. Hypertension or urinary retention may result from involvement of the autonomic system. There may be paresthesias.

Involvement of cranial nerves VIII, IX, X and XI may occur. The most frequently involved one is, however, facial nerve. Infrequently, the disorder may present as ataxia. GBS with involvement of cranial nerves and cerebellar signs is termed *Miller-Fisher variant*.

Diagnosis

The CSF usually shows a characteristic albuminocytological dissociation towards the second week of illness. Often the protein may be as high as 400 to 500 mg% although the cell count remains normal or only slightly raised. The so-called *cytoalbuminous dissociation* (also called “albuminocytologic dissociation”) in a child with acute or subacute polyneuropathy is considered pathognomonic (diagnostic) of Guillain-Barré syndrome.

Motor nerve conduction velocities and sensory conduction time are slow.

EMG reveals acute denervation of muscle.

Muscle and nerve biopsies, though not needed for diagnosis, show denervation atrophy and demyelination, degeneration and inflammation, respectively.

Differential Diagnosis

Differential diagnosis is from:

1. Acute flaccid paralysis (AFP) i.e. poliomyelitis, traumatic myelitis and transverse myelitis
2. Polyneuritis following diphtheria, enteric fever, botulism, tick-bite paralysis and
3. Other illnesses like polymyositis and cerebellar ataxia.

Treatment

Supportive treatment is more or less on the same lines as in poliomyelitis.

Plasma exchange (plasmapheresis) or high dose intravenous gamma globulins (IVIG), 1 g/kg/day for 2 days or 400 mg/kg/day for 5 days, is the treatment of choice at present. This treatment helps by removing the circulating immune complexes.

Steroids, including high dose pulsed methylprednisolone by intravenous route, though employed in the past, are no longer recommended.

Severe illness with respiratory paralysis/failure requires management with assisted ventilation. Prevention of decubitus ulcers in case of flaccid tetraplegia and prevention/treatment of secondary bacterial infections are vital.

Chronic relapsing Guillain-Barre syndrome needs repeated plasma exchange. Steroids, especially high dose pulsed methylprednisolone by intravenous route, may be employed as less effective alternative modality.

Prognosis

Most cases (60-70%) usually show complete recovery within a few weeks to months. At times it may take as much as 2 years. Mortality (around 5%) is usually secondary to respiratory complications.

Many subjects with chronic relapsing Guillain-Barré syndrome end up with considerable residual disability in the form of foot drop, pes cavus, postural tremors and weakness of limbs and trunk.

MENTAL RETARDATION

Infants and children with low learning capacity, poor maturation and inadequate social adjustment are grouped under this term.

Table 23.3 gives the current classification of mental retardation. The old classification, expressing mental retardation in terms of *idiot*, *imbecile* and *dull*—which have taken derogatory meanings is no longer employed.

Borderline mental retardation (IQ 68 to 83) refers to children who are vulnerable to educational difficulties which are usually sorted out with special help in regular classes.

Mild mental retardation (IQ 52 to 57) refers to children needing at least some special class placement; some may attain 4th to 6th class reading levels.

Moderate mental retardation (IQ 36 to 51) refers to children capable of attaining academic skills up to 2nd class; educational goals are targeted at gaining maximal self-care primarily.

Severe mental retardation (IQ 20 to 35) refers to children who can learn only minimal self-care and simple conversational skills; much supervision is a must.

Profound mental retardation (IQ under 20) refers to children with minimal language development and only very minimal self-care skills; total supervision is a must.

It is customary to designate mild mental retardation as educable and moderate mental retardation as trainable. The severe and profound mental retardation is termed custodial. Nevertheless, remember, some degree of education and training is possible even in the severe and profoundly retarded children.

Table 23.3: Current classification of mental retardation

Intelligence quotient (IQ*)	Degree of mental retardation
68 to 83	Borderline
52 to 67	Mild
36 to 51	Moderate
20 to 35	Severe
Below 20	Profound
	Assessed mental age

$$*IQ = \frac{\text{Assessed mental age}}{\text{Chronologic age}} \times 100$$

Epidemiology

Prevalence of mental retardation (IQ under 68) in general population is nearly 3%. A vast majority of them (80 to 90%) are only mildly retarded; only 5% are with severe to profound impairment.

Etiology

Mental retardation may be as a result of prenatal, perinatal or postnatal causes.

A. Prenatal

1. *Genetic:* Galactosemia, gargoylism, phenylketonuria, Niemann-Pick disease, Gaucher disease, microcephaly, craniosynostosis and congenital hydrocephalus.
2. *Chromosomal:* Down syndrome. Turner syndrome. Klinefelter syndrome, Fragile X syndrome.
3. *Maternal infections:* Rubella (Fig. 23.7), toxomoplasmosis, cytomegalic inclusion disease, syphilis and chickenpox.
4. *Maternal diseases:* Toxemias of pregnancy, lead poisoning, teratogenic agents, irradiation.

B. Perinatal

1. Birth trauma, cerebral anoxia, hemorrhage, sub-dural hematoma.
2. Prematurity, "small-for-dates" infant.

C. Postnatal

1. *Infections:* Encephalitis, meningitis.
2. *Trauma:* Head injury, subdural hematoma.
3. *Encephalopathy:* Whooping cough, toxic.
4. Kernicterus.



Fig. 23.7: Microcephaly with mental retardation. Cause: maternal rubella

5. *Cerebrovascular episodes*: Thrombosis of cerebral arteries and veins.
6. Hypothyroidism.
7. *Metabolic*: Hypoglycemia, hypocalcemia and profound electrolyte imbalance.
8. *Cultural (postnatal experiential disruptions)*: Poverty and family disorganization, faulty infant-caretaker interaction, parental psychopathology, parental drug abuse.
9. Gross PEM in early infancy.

Quite a proportion of children suffering from mental retardation may not fit into any of the known causes mentioned above. Equally noteworthy is the fact that, besides the etiologic factors (more exactly the potential contributory factors), there are at least four predisposing factors for mental retardation, namely poor socioeconomic status, low birthweight, advanced maternal age and consanguinity. All these predisposing factors render a subject, prenatally, or postnatally, vulnerable to the etiologic or contributory influences.

Genetic syndromes associated with mental retardation include Down syndrome, Edward syndrome, Fragile X syndrome, Klinefelter syndrome, PKU, tuberous sclerosis, neurofibromatosis, galactosemia, gargoylism, and Leisch-Nyhan syndrome.

Preventable mental retardation embraces such conditions as (a) cretinism (b) galactosemia, (c) PEM and (d) phenylketonuria (PKU).

Clinical Features

Failure to meet age-appropriate expectations such as delayed speech, language disabilities and delayed motor milestones, constitutes the hallmark of clinical manifestations. Hyperactivity, poor memory, poor attention, poor concentration, distractibility, emotional instability, sleep problems, impulsiveness and awkward (clumsy) movements and seizures are usually present in some combinations.

In certain conditions such as Down syndrome, primary microcephaly, cretinism, mucopolysaccharidosis, etc, specific physical features may clinch the diagnosis right at birth or during early infancy.

The following atypical features are associated with enhanced incidence of mental retardation:

Head Microcrania, macrocrania.

Scalp hair Double whorl, white lock, sparseness, absence.

Eyes Microphthalmia, slant, hyper- or hypotelorism, epicanthal fold, Brushfield spots, coloboma, nystagmus, abnormal position of pupil.

Ears Low-set, simple or abnormal formation.

Nose Flat, bridge, upturned nares, small size.

Face Hypoplastic jaw(s), increased length of philtrum.

Mouth V-shaped (inverted) upper lip, high-arched palate.

Teeth Abnormal enamelogenesis or odontogenesis.

Hands Short, stubby fingers, long, thin tapered fingers, broad thumb, clinodactyly, abnormal nails, transverse palmar crease, short 4th or 5th metacarpals, abnormal dermatoglyphics (say, distal triradius).

Feet Short, stubby toes, broad large big toes, overlap of toes, deep crease leading from angle of first and second toes, short 4th and 5th metatarsals, abnormal dermatoglyphics.

External genitalia Large testicles, micropenis, ambiguous genitalia.

Diagnosis

Clinical diagnosis is made from the pointers in the history and physical examination, including fundoscopy and developmental assessment. Eventually, IQ testing, confirming that intellectual functioning is more than 2 SD below the mean age, by an expert should be done.

Assessment of Mental Age

The commonly employed methods include:

- a. Stanford-Binet scale
- b. Wechsler scale
- c. Bhatia-scale

For children under 5 years, Denver or Gessel developmental system may be employed for rough estimate of the developmental age. Thereafter, mental age may be approximately evaluated as per below:

6 years: Recognition of the family members and telling the details; counting 1 to 20.

7 years: Telling completely the parts of the body: drawing a figure of man.

8 years: Names the days of the week and months of the year.

9 years: Does simple calculations such as involving coins.

10 years: Does complete arithmetic calculations; solves a problem.

Such investigations as urine chromatography, urine tests for metabolic disorders, chromosomal studies, biopsies, serologic tests, hormonal or enzyme assays. X-rays, CSF, ECG, angiography, CT scan, magnetic resonance imaging (MRI), etc. are indicated in special situations only.

Differential Diagnosis

Differential diagnosis is from the so-called *pseudo-mental retardation* which may be secondary to:

- Psychiatric problems like autism
- Speech/hearing problems
- Deprivation (cultural, educational, environmental, emotional, or sensory in the form of deafness or blindness)
- Motor disability (paralysis, chronic myopathy).

4 Management

Multidisciplinary approach with a spotlight on specialized educational and therapeutic services forms the backbone of management of child with mental retardation.

The family needs not only to be fully informed about the various aspects of child's disability but also wisely counseled and provided emotional support.

The child must be provided with the routine basic healthcare, including immunization, growth monitoring and therapy of illness as and when need be. Management of common accompaniments of mental retardation like seizures, impaired vision and hearing, musculoskeletal disability, hyperactivity, squint, etc. is vital. Central to all management is the warmth and appreciation of the care giver rather than harsh criticism.

Today, thanks to welcome changes in social and political attitudes towards individuals with mental retardation over the last couple of decades, we no longer recommend placement of the mentally retarded in residential institutions (the so-called *institutionalization*). The trend now is to develop community-based service system, e.g. day-care centers, schools, integrated schools, vocational training centers, sheltered farms and workshops, which coordinate services for both the child and his parents. The goal is to normalize the life of the child and his family rather than to pass the buck by putting the child away as was the practice in the past.

Prevention

The crux of all endeavors aimed at preventing mental retardation is promotion of healthy brain, intellectual development and provision of a nurturing and growth-promoting environment. The following measures may be of special help:

- Emphasis on the overall welfare of the girl child, the future mother, ensuring that her nutritional status is good and that she is safeguarded against teenage pregnancy as also that she has been adequately vaccinated against rubella.
- Avoidance of consanguinous marriages. Risk of metabolic disorders of recessive inheritance appearing in homozygous form is high in such unions.
- Mothers beyond 35 years of age need to be informed about the enhanced risk of birth of a child with Down syndrome.
- During labor, birth trauma and neonatal asphyxia must be prevented through good obstetric care.
- After birth, such causes of mental retardation as hyperbilirubinemia, meningitis, cretinism, galactosemia and phenylketonuria must be promptly identified and managed adequately.
- Prevention and management of low-birth weight infants as also malnutrition in infancy and early childhood.

DOWN SYNDROME (*Mongolism*)

Down syndrome is perhaps the most common among the well-recognized causes of mental retardation. Three types are known:

- *Trisomy 21* (95% cases) which results from the presence of an extra-chromosome 21. Such a mongol has 47 chromosomes instead of the normal 46. Also called *Trisomy G*, it is associated with advancing maternal age. A mongol is generally either first born or an exhaustion product, i.e. last of a series of pregnancies.
- *Translocation* of chromosome 21 with chromosome 13, 14 or 15 (4% cases). In this type the total number remains the normal 46 though one chromosome is large and atypical.
- Occasionally (1% cases), *mosaicism* may occur.

Incidence in India is 2.2 per 1,000 live births which is higher than the average overall figure of 1 in 600 for all races.

Clinical Features

The clinical picture is characteristic, having striking resemblance to mongolian races like Chinese, Tibetans, Japanese, etc. as far as facial appearance is concerned (Figs 23.8 to 23.10).

A mongol has been rightly described as a *cheerful idiot*. Unlike a cretin (Fig. 23.11), he is affectionate, friendly, fond of music and has grossly delayed milestones, both physical and mental. The maximum mental age is seldom beyond 8 years. The average IQ is about 40.

Head is microcephalic with flattening of the occiput.



Fig. 23.8: Down syndrome. Note the classical facial features in two infants



Fig. 23.9: Profile of a child with Down syndrome



Fig. 23.10: Down syndrome. Note the characteristic facial features

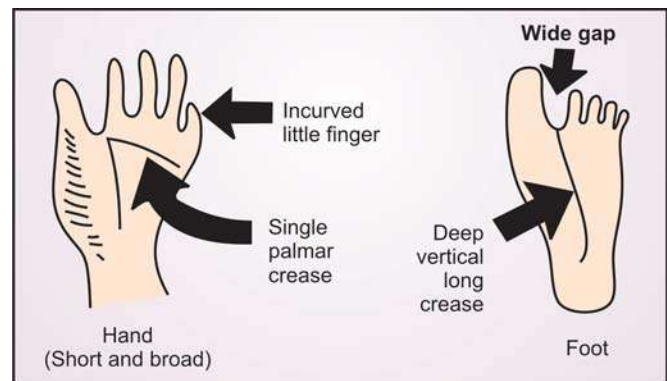

Fig. 23.11: Hand and sole of foot in Down syndrome

Facial features include eyes having *upward, slant[†], epicanthal folds* (generally at the inner angles) and occasionally *Brushfields spots* (small whitish spots near the periphery of the iris). Incidence of late-onset cataract is high. Tongue is protruded from the small buccal cavity and may be furrowed (*scrotal tongue*). Nose is short and its bridge flat. This together with epicanthal folds, gives an impression of increased distance between the eyes (*pseudohypertelorism*). Ears are low-set* and often deformed; ear lobes may be absent or small. High-arched palate and malocclusion of the teeth may be present.

Neck is short and broad. Often the head seems to be almost resting on trunk. Hairline is usually low.

† Mongoloid slant may also be seen in Laurence-Moon-Biedl syndrome. Its opposite, "antimongoloid slant" is usually encountered in Apert syndrome, Treacher-Collins syndrome, cerebral gigantism and de Lange syndrome.

* A low-set ear lies below an imaginary line joining the lateral angle of the eye to the posterior occipital protuberance

Hands are short and broad; little finger is short and incurved due to rudimentary middle phalanx. The normal 3 major creases may be replaced by a single transverse line called *Simian crease* (see Figs 23.11 and 23.12).

Feet show wide gap between the big and second toes and, at times, a deep crease starting between them and extending on the sole (see Fig. 23.11).

Generalized hypotonia is usually present. Mongolism should be considered in the differential diagnosis of the so-called *floppy baby syndrome*. As the child grows, hypotonia gradually diminishes.

Mongols are highly susceptible to recurrent respiratory infections. Poor development of the paranasal sinuses is responsible for recurrent upper airway infection. Associate congenital heart disease (usually atrioventricular canal, VSD or ASD: rarely TOF) is a common finding. Moreover, they are 10 times more prone to development of leukemia than the normal population. Newborns with mongolism are more likely to develop intestinal obstruction due to duodenal atresia. Likewise, *Hirschsprung disease* occurs more often in mongols than in others. Around 10% cases of Down syndrome have biopsy-proven celiac disease.

Diagnosis

Clinical picture is invariably so characteristic that the diagnosis is apparent. The difference between mongolism and cretinism are presented in Table 23.4. Also, see Chapter 34 (Pediatric Endocrinology).

The clinical diagnosis may be confirmed by chromosomal studies.



Fig. 23.12: Simian (single palmar) crease in Down syndrome

Table 23.4 : Down syndrome vs cretinism

<i>Down syndrome</i>	<i>Cretinism</i>
Cheerful	Repulsive
Active	Lethargic
Microcephaly with flattening of occiput	Generally absent
Fine tender skin	Rough skin
Upward slant of eyes	Absent
Epicanthal fold	Absent
Protruding, furrowed but normal-sized tongue	Large protruding tongue
Simian crease	Absent
Higher incidence of congenital heart disease, Hirschsprung disease, duodenal atresia and leukemia	No such predisposition
No definitive treatment available as it is of chromosomal etiology*	Replacement therapy available; it is a state of hypothyroidism.
Maximum IQ attained, despite the best of efforts, is that of an 8-year-old	With adequate replacement therapy, started in first few months of life, IQ of 90 may be achieved

* Administration of 5-hydroxytryptophan is reported to revert the hypotonia

Radiologic Findings

- Only 11 ribs
- Two to 3 ossification centers of manubrium
- Hypoplasia of base of skull, facial bones and middle phalanx of fifth finger
- Accessory epiphysis at base of second metacarpal
- Coxa valga
- Bony pelvis: Iliac are broad and flared; acetabular and iliac angles are reduced.

Dermatoglyphic Findings

- Distal palmar axial triradius or large angle, hypotenar patterns, distal loop in the third interdigital area
- Predominance of ulnar loops on the digits and radial loops on 4th and 5th fingers
- Hallucal arch tibial pattern in the feet
- Marked crease between great and second toes.

Management

The cornerstone of management of Down syndrome is to help the child to make the best of his limited

abilities. Special education and occupational training are known to have helped many such patient not only to take care of their person but also to carry occupations not requiring much sophistication. The consensus is against early institutionalization. The useful impact of institutionalization, done when the child is old enough, is, however, well-recognized.

Symptomatic treatment, as and when indicated, must be given. Recurrent respiratory infections are common. Antibiotics, if indicated, may be needed to control such an infection.

Parental counseling: How risky will it be to have another child?

- A. Child has trisomy 21, parents have normal karyotypes:** *The risk is only slightly greater than for parents in the general population (1 to 2%).*
- B. Trisomy child, one parent mosaic:** *The risk will depend upon the degree of gonadal mosaicism of the affected. A rough estimate will be half of the proportion of abnormal cells in fibroblast cultures of the cells obtained from the parent.*
- C. Child has 14/21 (D/G) translocation, parents have normal karyotype:** *The risks are unknown but should be considered slightly increased.*
- D. Child has 14/21 (D/C) translocation carrier:** *Two possible situations may arise. Firstly, when the mother is a carrier, about 15% of the children may be affected, one-third may be carriers and the remainder completely normal. Secondly, when the father is a carrier, there is 3 to 5% chance of having another affected child and half of the apparently unaffected children may be carriers.*
- E. Child has a 21/22 (G/G) translocation:** *If both the parents have normal karyotype, the prognosis is roughly the same as under "A" although there is some evidence that advancing paternal age may increase the risk slightly. If, on the other hand, only one parent carries the translocation, the risk is 100% in case of an isochromosome of 21 (21/21) and same as under "D" in case of a 21/22 translocation.*

AUTISM

Autism is characterized by a qualitative impairment in verbal and nonverbal communication, in imaginative activity and in reciprocal social interaction. Incidence of low intelligence, epilepsy, self-injurious behavior and fragile X syndrome (in families) is high. For details, see Chapter 5 (Developmental Disorders).

CEREBRAL PALSY (*Little Disease**)

Cerebral palsy (CP) is a form of chronic motor disability which is *nonprogressive, nonfatal* and yet *noncurable* and results from damage to the growing brain before or during birth, or in postnatal period. It is the **most common cause of crippling in children**. Though mental retardation is associated in about 25 to 50% cases of cerebral palsy, it is, by no means, an essential feature of the clinical picture. The other handicaps that the patient may have are epilepsy, orthopedic deformities, partial or complete deafness and blindness, psychologic disturbances, etc (Fig. 23.13).

Epidemiology

According to conservative estimates, prevalence rate of CP is in the vicinity of 4 per 1,000 live births. Since mild cases are likely to be missed in surveys, the prevalence of CP may well be higher than this estimate.

Etiology

It is more or less the same as in case of mental retardation with the following differences:

- i. Genetic and chromosomal factors do not operate here



Fig. 23.13: Cerebral palsy

* After the name of John Little, an orthopedic surgeon who first described it in 1862

ii. Of the postnatal factors, hypothyroidism cultural influences and PEM have nothing to do in the etiology of cerebral palsy. Cerebral anoxia, often accompanied by intraventricular and subependymal hemorrhages followed by physical birth trauma to the brain, kernicterus and congenital malformations of brain was believed to account for a large chunk of cases of cerebral palsy.

Recently, convincing evidence has collected to show that birth asphyxia, earlier believed to be a leading cause of CP, is, in fact an uncommon etiologic factor in this entity. Current thinking is that roots of pathogenesis of CP may well be in the developmental biology.

Pathology

4 In milder CP, brain grossly appears normal but is underweight and has only sparse subcortical white matter and sparse nerve fibres.

The findings in severe CP include widespread cerebral atrophy, cavity formation in subcortical white matter, atrophy of basal ganglia and porencephalitis.

Clinical Features

The following classifications are useful:

I. Classification based on motor deficit and distribution of handicap

- i. Spastic CP (Pyramidal CP)
 - Quadriplegia
 - Paraplegia
 - Hemiplegia
 - Monoplegia
- ii. Extrapyramidal CP
 - Choreoathetosis
 - Dystonia
- iii. Atonic CP (Cerebellar CP)
 - Atonic diplegia
 - Congenital cerebellar ataxia.
- iv. Mixed CP

II. Classification based on patient's status about functional capacity

Class I: No practical limitation of activity.

Class II: Slight to moderate limitation of activity.

Class III: Moderate to gross limitation of activity.

Class IV: Inability to carry on any useful physical activity.

III. Classification based on patient's status about therapeutic needs

Class I: Not requiring any treatment.

Class II: Requiring minimal bracing and minimal therapy.

Class III: Requiring bracing and services of a cerebral palsy team.

Class IV: Requiring long-term institutionalization and treatment.

Spastic cerebral palsy is the type most frequently encountered in clinical practice. The classical form consists of spasticity of both upper as well as lower limbs, legs being more severely affected than the arms (*diplegia* rather than *quadriplegia*). In some case, the picture may be that of *hemiplegia*, *monoplegia* or *triplegia*.

Besides spasticity, deep tendon reflexes are brisk and ankle clonus may be positive. Also, plantars may be extensor. Sudden lifting of the child may produce visible adductor spasm and even "crossing of the legs", the so-called *scissoring*, which is characteristic of cerebral palsy.

As the child grows in age, spasticity and rigidity become more pronounced with development of abnormal postures and contractures, especially at heels, hips and elbow.

Bilateral spasticity may lead to pseudobulbar palsy and resultant swallowing difficulties and excessive drooling.

Cerebral palsy of this type can be diagnosed fairly early in infancy. Delay in attaining motor milestones and persistence of *Moro grasp*, *tonic neck* and other primitive reflexes after the age of 3 months should arouse suspicion.

Handicaps/Comorbidity

On top of disability from cerebral palsy *per se*, a child with CP may have quite a few associated handicaps as shown in Table 23.5.

Diagnosis

Cerebral palsy must be considered in every child who fails to keep pace in attainment of milestones with the range of expected for the age. This diagnosis becomes more likely if there is evidence of abnormalities of posture, involuntary movements and neurologic deficit.

Table 23.5: Common associations/handicaps (Comorbidity) in cerebral palsy

CNS	
Variable degree of mental retardation	
Behavioral problems	
Seizures	
Eyes	
Squint	
Retinopathy of prematurity (ROP)	Cataract
Coloboma	Refractive errors
Perceptual errors	Blindness (partial or complete)
Ears	
Deafness (partial or complete)	Receptive auditory aphasia
Speech	
Aphasia	Dyslalia
Dysarthria	
Sensory	
Spatial disorientation	Astereognosis
GIT	
Constipation	Incontinence
Teeth	
Malocclusion, caries	
Miscellaneous	
Feeding difficulties	Drooling
Recurrent infections	

A detailed history and physical examination with special reference to neurological and developmental status, language and learning disability, hearing and visual function evaluation, and psychometric and sensory deficit is vital. Attempts must be made to rule out muscular dystrophy, degenerative disease, or spinal cord tumor.

In order to localize the site and extent of the structural lesions or accompanied congenital malformations, EEG and CT scan may be done.

Treatment

The major aim of treatment in cerebral palsy is to achieve maximum possible functional ability and skill in keeping with his developmental age. This is primarily achieved through physiotherapy, surgical corrections and occupational therapy.

Spasticity may warrant use of *drug therapy* with diazepam, dantrolene sodium or baclofen, hypotonia with strychnine, athetosis with chlordiazepoxide or levodopa, dystonia with carbamazepine or triexphenidyl and epilepsy with anticonvulsants.

Physiotherapy forms the cornerstone of management of CP. The subject is trained in relaxing the spastic muscles, encouraged to do active exercise to establish movement pattern and taught rhythmic contractions and relaxation of muscles. For assisting them to stand and walk, walking calipers are prescribed. In order to maintain the proper sleep posture (knee, foot and hand), night splints are used.

Occupational therapy involves the positive application of certain repetitive movements of legs, hands and fingers to relax the spastic muscles. They are also trained for some occupation when they grow up so that they turn out to be economically self-sufficient.

Surgical/orthopedic therapy is targetted at correcting the deformities and stabilizing the joints.

Recently, gratifying results have been obtained by the procedure, *selective posterior rhizotomy*, in children with spastic CP involving primarily the lower limbs. In this surgical procedure, posterior rootlets of the cauda equina are stimulated electrically whereas abnormal ones are sectioned. In properly selected cases, the spasticity subsides right on the operation table. Eventually, significant gain in milestones to the extent of walking can be obtained. Nonetheless, rehabilitative therapy needs to be continued to compliment the positive outcome of the surgery, and obtain the best results.

Finally, management of CP is a teamwork, requiring coordination between the physicians from various specialties, surgeons, physical and occupational therapists, speech therapist, social worker, educator, development psychologist, parents and the child. Such voluntary organizations as the *Spastic Society of India*, launched in 1972, and *Indian Family of Cerebral Palsy*, launched in 1993, to serve the interests of the cerebral palsy-affected children, need to be encouraged.

Prevention

Better obstetric and neonatal care prevents birth trauma, asphyxia and neonatal jaundice and thus much of CP. It has recently been suggested that future developments targetted at enhancing perinatal care may have only marginal effect on the prevalence of CP. It may be worth-while to direct research to the area of developmental biology as well.

Early and prompt detection of CP cases and adequate planning for management may help indirectly by reducing residual neurologic, psychosocial, and other handicaps, and making child's life comfortable.

MENINGITIS

Meningitis refers to the inflammation of the meninges overlying the brain and the spinal cord*. It is one of the most dreadful emergencies met with in pediatric practice. The fatality rate is high. Two types are generally recognized.

- *Pyogenic or bacterial*: *H. influenzae*, pneumococcal, meningococcal, staphylococcal, streptococcal and *E. coli* infection.
- *Aseptic*: Tuberculous, viral, fungal and protozoal (toxoplasmosis, amebic).

4 BACTERIAL MENINGITIS

Bacterial meningitis accounts for around 5% of the pediatric admissions in our country. It results from either primary infection of the meninges or spread from a nearby pyogenic focus. At times, metastatic spread from a distant focus also causes this disease. In our country, *H. Influenzae* and *Pneumococcus* are the leading causative agents. *Meningococcus*,** *Staphylococcus* and *Streptococcus* are less common. *E. coli* is infrequent indeed, except in neonatal meningitis. *H. influenzae*, in particular, affects mostly the infants and young children (Table 23.6).

Clinical Features

As a rule, the onset is sudden with high fever, vomiting, restlessness, irritability, headache and often convulsions. In newborns and small infants, pyogenic meningitis may have insidious onset with meagre symptoms like refusal to take feed, fever and irritability. Some may have convulsions. These, especially in the presence of bulging anterior fontanel, should arouse suspicion of meningitis.

Physical examination may reveal *neck stiffness*, and positive *Kernig* and *Brudzinski signs*. Cranial nerve palsies and papilledema are present in some cases. Hemiplegia may be noticed in a few cases who report late to the doctor.

* Strictly speaking, the term meningitis is a misnomer since it is virtually impossible that inflammation is limited to the meninges only. Meningoencephalitis is a better nomenclature.

** Caused epidemic of meningococcal meningitis in Delhi in early 1985

Meningococcal meningitis is characterized by the presence of a generalized purpuric rash* which is only infrequently seen in dark-skinned children. *Meningococemia* may, in certain cases, dominate the clinical picture of meningitis. Such cases become rapidly comatose and have toxemia, cyanosis and purple mottling of the skin. This is called *Waterhouse-Friderichsen syndrome*.

Diagnosis

Lumbar puncture is a "must" in any child in whom meningitis is suspected. CSF is generally under increased pressure and frankly turbid or little opalescent. Cell count is greatly increased, a large proportion of these being polymorphs. CSF proteins are greatly increased. But, sugar is considerably reduced, invariably below 30 and often as low as 10 to 20 mg%.

CSF *culture* should be done for identifying the causative organisms and their antibiotic sensitivity, provided such facilities are available.

NBT (nitroblue tetrazolium) test is a useful adjunct to differentiate it from tuberculous meningitis; so is *countercurrent immunoelectrophoresis*.

Table 23.6: Age-wise etiology of pyogenic meningitis

Under 2 months

- Gram-negative organisms, esp *E. coli*
- Group B beta-*Streptococcus hemolyticus*
- *Listeria monocytogenes*

2 months to 6 years

- *H. influenzae*
- *Pneumococcus*
- *N. meningitidis*

Beyond 6 years

- *Pneumococcus*
- *N. meningitidis*

Treatment

Today, initial treatment of choice is ceftriaxone or cefotaxime (IV). Alternative choice is ampicillin, given intravenously in a dose of 100 to 400 mg/kg/day. The low dose is only for newborns under 7 days of age. In them it should be combined with gentamicin, 6 mg/kg/day, or kanamycin, 10 to 15 mg/kg/day.

* Such a rash may also be seen in pneumococcal meningitis, influenza (type B) and some other viral infections

If the patient is hypersensitive to penicillin, ampicillin should not be given. Chloramphenicol, 50 to 100 mg/kg/day, is the next best agent. In a newborn, either it should be avoided or given in a low dose, i.e. 25 mg/kg/day, because of the risk of serious toxicity (gray baby syndrome).

Though condemned by some authorities, the combination of chloroamphenicol and penicillin continues to find favor with many pediatricians.

Intrathecal administration of antibiotics, particularly initially, may be considered in neonates and patients with advanced disease.

Rising intracranial pressure may be controlled by intravenous mannitol.

Corticosteroids, over a short period, are indicated in critically sick cases, especially in the presence of shock, excessive thick exudate and persistent elevation of CSF pressure.

Convulsions should be treated with phenobarbital, diazepam or other anticonvulsants.

Other supportive measures include maintenance of hydration, nutrition (intravenous drip is almost indispensable for first few days), vitamin supplements and good nursing care.

Recurrence of fever in a child under treatment may well be due to (a) phlebitis, (b) drug fever, (c) superadded infection, (d) inadequate or inappropriate antibiotics for the causative organisms, (e) abscess, effusion or otitis media.

Prognosis

The outlook has now considerably improved with the availability of modern antibiotics. Most of the mortality is confined to neonatal meningitis.

The complications include subdural effusion, brain-abscess, deafness, blindness, ocular paralysis and hydrocephalus.

The sequelae include mental retardation, epilepsy, speech problems, hearing loss (due to labyrinthitis, or direct inflammation of auditory nerve), visual impairment, varying pareses, hydrocephalus, diabetes insipidus, obesity and precocious puberty.

CNS TUBERCULOSIS (NEUROTUBERCULOSIS)

Four major forms of neurotuberculosis are:

1. Tuberculous meningitis.

This has already been described above.

2. Tuberculous encephalopathy.
3. Tuberculoma.
4. Tuberculosis of the spine.

TUBERCULOUS MENINGITIS (TBM)

Tuberculous meningitis is the most common and the most serious form of CNS tuberculosis. Around 12-20% of children with tuberculosis have TBM (Chapter 23).

Epidemiology

The incidence is particularly high in dark races, the Negroes being the toppers. There is wide variation in the reported incidence from various centers in our country. In Amritsar series it accounted for 1.4% of the pediatric admissions. The corresponding figures from Chandigarh, Simla and Jammu are 1.8%, 2.5% and 2.9%, respectively.

The maximum risk of TBM is 3 to 6 months after the primary infection and much less after a year. Hence, highest incidence is recorded in the pre-schoolers.

TBM and miliary tuberculosis do not always coexist though TBM is always the result of hematogenous spread from primary lesion(s) elsewhere. This lesion may be neither clinically manifest nor detectable.

History of an illness like measles may precede the onset of TBM.

BCG vaccination brings down the incidence and severity but does not prevent TBM.

Etiopathogenesis

In a large majority of the cases, TBM is due to human *M. tuberculosis* and is always a secondary lesion with the primary usually in the lung. The involvement of meninges is believed to be from the discharge of the bacilli in the CSF by the small tuberculoma in the cortex of spinal cord or tuberculous lesion of the vertebrae. At times, tuberculosis of the choroid plexus may be the site for the spread of infection to the meninges. Small tubercles are scattered over the convexity of the brain or periventricular area (Fig. 23.14).

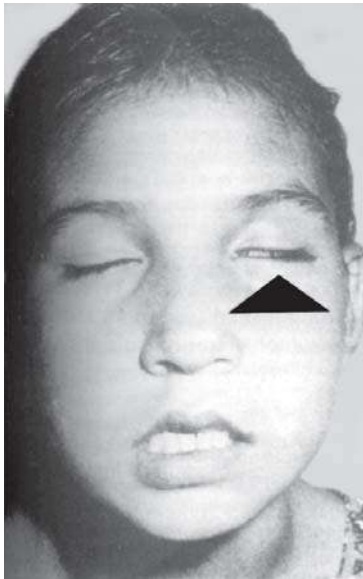

Fig. 23.14: Facial palsy in a girl with tuberculous meningitis (TBM)

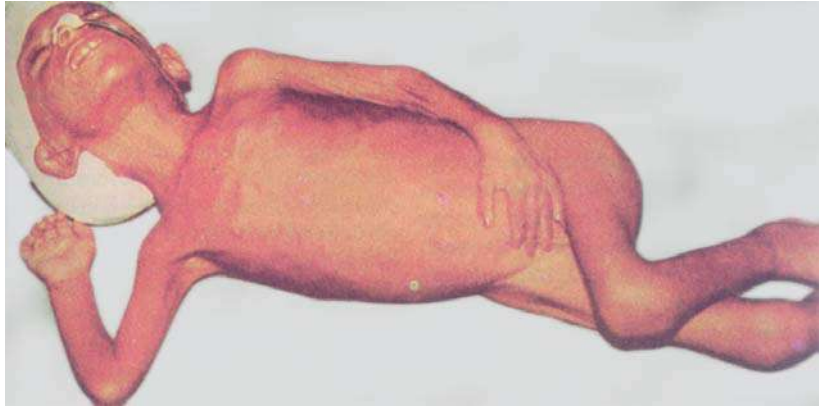

Fig. 23.15: Tuberculous meningitis (TBM). Note features of the stage 3 plus gross malnutrition

4

Clinical Features

In a classical case, TBM has insidious onset. Acute onset is frequent in infancy, however. The course of illness may be divided into 3 stages: prodromal, transitional or terminal.

First or prodromal stage Here the symptoms are vague and include change in disposition and temperament (apathy or irritability), drowsiness, mild fever, convulsions, anorexia, vomiting, constipation and headache.

Second or transitional stage During this stage, manifestations of raised intracranial tension and meningeal irritation appear. Child becomes progressively drowsy and even unconscious. Headache, vomiting and feverishness become more aggravated. Neck rigidity and Kerning sign become positive. Plantar reflexes may become extensor. Ankle and patellar clonus may be elicitable. Abdominal reflexes, on the contrary, disappear. Hypertonia is usually present, so are the seizures. In small infants anterior fontanel may be bulging. Cranial nerves involved are 3rd, 4th, 6th and 7th (Fig. 23.14). Ocular paralysis, strabismus, nystagmus and contracted pupils are common. Also, there may be papilledema. Choroid tubercles along the blood vessels of choroid plexus may be seen in a small proportion of the cases.

Third or terminal stage This is the *stage of paralysis and coma* (Fig. 23.15) although there may be short periods of wakefulness. Signs of meningeal irritation are no longer prominent. Pupils are dilated and fixed. Clonic spasms of limbs, irregular respiration, irregular pulse (slow or rapid), rising fever and widespread paralysis are present. If treatment is delayed or inadequate, hydrocephalus invariably develops in infants and small children.

Roughly, each of the stages described above lasts for about a week or so. There may be considerable overlap of the three stages. With treatment, there may be prolongation or even absence of one of the stages.

Remember also that, TBM may have *odd presentation* simulating typhoid, brain tumor, status epilepticus, poliomyelitis, spinal cord compression, congenital hydrocephalus, acute abdomen, intracranial injury, gastritis, or bronchopneumonia. In grossly malnourished children, TBM may present in the form of irregular *but* persistent pyrexia without significant manifestations of meningeal involvement. Rarely, a case of TBM may remain conscious throughout illness. Coexistence of both TBM and pyogenic meningitis in the same patient has infrequently been observed by us as well as by others. The same is true about TBM and typhoid.

Diagnosis

Early diagnosis is of utmost importance for full recovery as well as prevention of complications and/or sequelae.

- *Suspicion* A high index of clinical suspicion, especially in areas where tuberculosis is common, goes a long way in detecting the cases at early stages.
- *Mantoux test/BCG test* (see Chapter 10).
- *Lumbar puncture* CSF provides most dependable information. It gushes out under high pressure and is clear or, occasionally, slightly turbid. When it is kept in a test tube for 12 hours, a *cobweb* is formed. Microscopic examination shows an increase in cell count from 10 to 500/cmm with *predominance of lymphocytes*. In some cases with acute onset, especially in infants, CSF in early stage of TBM may show relative increase in polymorphonuclear cells.

Biochemical examination shows increase in proteins whereas sugar and chlorides are reduced. Absolute confirmation of the diagnosis is obtained by demonstration of the tuberculous bacilli in the CSF smear, by culture, or by guinea-pig inoculation.

- Supportive investigation include X-rays chest and skull, CT scan (Fig. 23.16) and ESR. Sputum or gastric lavage may be done. A lymph node biopsy, liver biopsy or bone marrow may be helpful in cases where diagnostic dilemma is indeed too much.

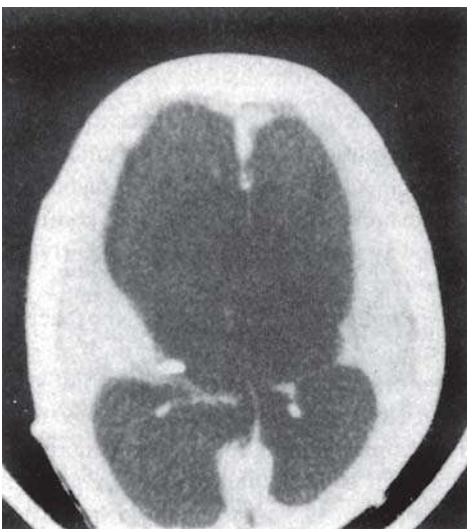

Fig. 23.16: CT scan demonstrating grossly dilated ventricular system in tuberculous meningitis (TBM)

Biochemical markers that yield quick results include bromide partition test, adenosine deaminase and tuber-culosterearic acid.

Serodiagnosis consists in detecting antigens, antibodies or immune complexes in CSF or, at times, in serum usually by ELISA.

Molecular diagnosis is by polymerase chain reaction (PCR) or DNA probing method, though very reliable, is very expensive.

Treatment

According to the Indian Academy of Pediatrics (IAP), chemotherapy consists of 2HRZE/10HRE with predni-solone as per Table 23.7.

Table 23.7: IAP recommended ATT for TBM

Drugs	Dosage	Duration
INH	5 mg/kg/day	12 months
Rifampicin	10 mg/kg/day	12 months
Pyrazinamide	25 mg/kg/day	2 months
Ethambutol	20 mg/kg/day	2 months
or		
Streptomycin	20 mg/kg/day	2 months
Prednisolone	1-2 mg/kg/day	8-12 weeks

The additional measures to reduce cerebral edema include administration of 20% mannitol, 100 to 200 ml (IV) twice daily for 5 to 7 days, glycerol 10%, 1.5 to 2g/kg (O or IV), or hypertonic glucose, fructose or urea.

Shunt is indicated in case of hydrocephalus, provided that CSF protein does not exceed 100 mg%. High CSF protein is likely to block the shunt.

Besides other symptomatic measures and nursing care, the child should receive an anticonvulsant like *phenobarbital* to control convulsions.

Prognosis

Without treatment, TBM, almost always ends fatally. Even with treatment, mortality is high. In our experience it is about 33 to 50%. In Mumbai, it is 15% in children of upper socioeconomic status and 50% in the poor. In an earlier series from Amritsar, it was as high as 82.9%.

Mortality figures are relatively higher in infants, in highly advanced cases (stage 3), development of seizures, delay in starting proper treatment and in malnourished children.



Fig. 23.17: Acquired hydrocephalus in a survivor from tuberculous meningitis

In developing regions, relapses do occasionally occur in those cases of TBM who receive inadequate antituberculous therapy.

Sequelae

The common *sequelae*, generally seen in survivors from third stage, are mental retardation, epilepsy, hydrocephalus (Fig. 23.17), cranial nerve paralysis, hemiplegia, spasticity, ataxia and endocrinal disturbances, in the form of obesity, diabetes insipidus, and precocious puberty.

TUBERCULOUS ENCEPHALOPATHY

The infants and children having *tuberculous encephalopathy without meningitis* have diffuse cerebral signs but the meningeal signs are remarkable by their absence. Alteration in sensorium in the form of drowsiness, semiconsciousness and even coma is invariably present. Convulsions are generally there. At times, abnormal movements, paralysis, decorticate or decerebrate spasm or rigidity and other manifestations of raised intracranial tension may be encountered. CSF is, however, normal but may show minimal rise in proteins and cells. Onset may be acute, subacute or vaguely chronic. "The manifestations are mild, moderate or severe, depending upon the severity of pathologic lesions of the brain cells.

The diagnosis of tuberculous encephalopathy should be seriously considered when one comes across a clinical picture described above. The presence of miliary, disseminated or intrathoracic tuberculosis helps in recognizing this entity. Even in the absence of clinical evidence of tuberculosis, the diagnosis may be suggested by exclusion of other conditions and, at times, only by brain biopsy or autopsy.

Histopathologically, the most important and consistent finding is the edema of the brain cells. This change is predominant in white matter though grey matter may also be affected. There may be perivascular or mononuclear reaction. Rarely, frank hemorrhagic spots may be noticed. There is, however, no significant involvement of the meninges though a few tiny tubercles in meninges or brain have been observed in some of the autopsied cases.

Treatment is more or less on the same lines as for TBM.

TUBERCULOMA

Tuberculoma is yet another type of CNS tuberculosis. About one-half of the intracranial space-occupying lesions are accounted by tuberculoma in tropical infants and children. Among the affluent segments of population the world over, its incidence is meagre.

Etiopathogenesis

Tuberculoma is always secondary to a primary tuberculous lesion elsewhere in the body. Since the host's resistance is good enough, the bacilli which spread to brain fail to cause meningitis. But they keep forming *granulomatous tissue* which is infratentorial in majority of the cases. Granulomata may, however, be supratentorial as well as scattered over multiple sites.

Clinical Features

Unlike other forms of tuberculosis, children suffering from tuberculoma appear adequately built and well-nourished.

Manifestations are those of other space-occupying lesions. The onset is usually gradual with vomiting, headache, cerebellar ataxia and diminished vision. Most of the patients have fever as well.

Diagnosis

Tuberculoma needs to be differentiated from brain abscess, subdural hematoma, brain tumor, cysticercosis, etc.

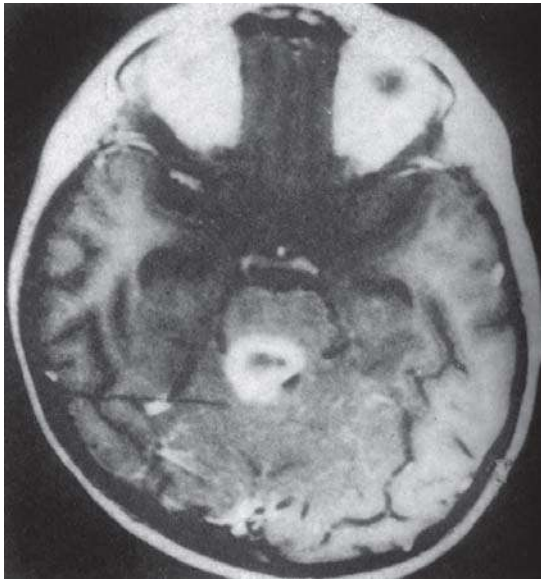

Fig. 23.18: MRI demonstrating a tuberculoma. Note the ringlike discrete lesion with considerable surrounding edema. Most often, pediatric tuberculoma is solitary and infratentorial, located at the base of the brain near the cerebellum

Diagnostic investigations have already been discussed.

Neuroimaging (CT or MRI) constitutes the most important modality for diagnosis. It usually is seen as a discrete lesion with a significant amount of surrounding edema (Fig. 23.18) in the form of a ringlike lesion which must be distinguished from that of neurocysticercosis (described later in this very Chapter).

Treatment

Antituberculous chemotherapy should be started as soon as the diagnosis has been made. Some cases may need surgical intervention to reduce the high intracranial pressure. Poor response is an indication for surgical excision rather than mere burr holes.

ENCEPHALITIS

The Greek term, *encephalitis*, signifies inflammation of the brain. Unless proved otherwise, it is due to direct viral invasion *via* hematogenous route, across olfactory mucosa, or along peripheral nerves, or some immunologic reaction in the nervous system of the host.

When cerebral dysfunction follows a functional metabolic defect in the brain cells or a circulating toxic agent, the condition is called *encephalopathy*. Encephalopathy may be static (e.g. cerebral palsy) or progressive (e.g. galactosemia, leukodystrophy). There is, however, considerable overlap and the two groups should not be considered as absolutely distinct and air-tight compartments.

Etiologic Considerations

The occurrence of viral encephalitis as a complication of *measles*, *chickenpox*, *mumps*, *herpes simplex* and *rabies* is well known. In addition, there is a relatively commoner variety of encephalitis which occurs in sporadic as well endemic forms in India and other countries. The vast majority of these cases are of *viral etiology* though identification of virus has not always been possible. In all probability, *enteroviruses* are responsible in most. Certain bacterial infections like *shigellosis*, *salmonellosis* and *scarlet fever* may, occasionally, cause *toxic encephalitis*. Besides, *pertussis*, *enteric fever* or *tuberculosis* may cause an encephalopathy that clinically resembles viral encephalitis.

It is worth mentioning that in some of the outbreaks of encephalitis, encountered during and after monsoon in India, the etiologic agent has proved to be a virus which is similar to *Japanese type B* serologically. It has been called *Tamil Nadu virus*. In other epidemic and sporadic cases of viral encephalitis, the etiologic agent appears to be *non-Japanese B enterovirus*.

In cases of the so-called *Nagpur encephalitis* or *encephalopathy*, it appears that, besides, enteroviruses, there may be additional etiologic factors such as other viruses and high environmental temperature.

Table 23.8 gives etiologic classification of encephalitis.

Clinical Features

The clinical picture of viral encephalitis is essentially similar, irrespective of the causative agent. The onset may be acute or gradual.

Manifestations include change in sensorium, varying from lethargy to coma, fever, vomiting and convulsions. Some children demonstrate peculiar

Table 23.8: Etiologic classification of encephalitis/encephalopathy**Viral**

Direct invasion: Abroviruses (Japanese B, Eastern and Western equine, Russian spring summer), ECHO viruses, Coxsackie viruses, polio, herpes simplex, rabies, mumps measles, rubella, cytomegalovirus.

Indirect invasion: Measles, chickenpox, rubella, varicella, mumps, infectious mononucleosis, influenza, rabies, Guillain-Barré syndrome.

Bacterial

Tuberculosis, enteric fever, cerebral abscess (at an early stage), pertussis.

Spirochetal

Syphilis, leptospirosis.

Protozoal

Toxoplasmosis, malaria, amebiasis.

Helminthiasis

Schistosomiasis, cysticercosis, hydatid disease.

Fungal

Histoplasmosis, aspergillosis, cryptococcosis.

Metabolic

Hyperbilirubinemia of newborn, diabetic ketoacidosis, uremia, hypoglycemia, Reye syndrome, electrolyte imbalance.

Toxic

Poisoning by lead, insecticides, carbon monoxide.

Physical and Environmental

Hyperpyrexia, heat stroke

Table 23.9: Progressive encephalopathies causing mental retardation

- Phenylketonuria (PKU)
- Galactosemia
- Hurler syndrome
- Tay-Sach disease
- Leukodystrophy
- Lesch-Nahan syndrome
- Tuberosus sclerosis
- Muscle dystrophy
- Subacute sclerosis panencephalitis (SSPE)
- Kuril

Diagnosis

Diagnosis is *essentially clinical* and is by exclusion of diseases, such as meningitis, encephalopathy, cerebral malaria, heat stroke and septicemia.

Lumbar puncture should always be done, not because encephalitis has any typical CSF picture but to rule out meningitis. CSF pressure is high but biochemistry is essentially normal. Sugar is either normal or little raised. Same is true of proteins. Slight pleocytosis with predominance of polys in first 48 hours and lymphos afterwards may be noticed.

Treatment

- A. Specific** As yet, there is nothing specific that can cure viral encephalitis.
- B. Symptomatic** General supportive measures form the cornerstone of management. It is advisable that such a patient is treated in a hospital. Besides general nursing care, involving attention to skin, bowel, bladder, etc. the following should be done:
 - i. *Intravenous fluids* An IV drip is essential to maintain nutrition and fluid and electrolyte balance in initial stages. Later, Ryle tube feeding may be done in cases whose coma lingers over a prolonged period. Vitamin and mineral supplements may be given, if needed.
 - ii. *Antibiotics* Since, under most situations, it may be nearly impossible to rule out a bacterial infection and since incidence of superadded bacterial infections is high, a good antibiotic shield is recommended. This is especially so in the initial stages of treatment.

behavior, hyperactivity, altered speech and ataxia. Headache is common in older children whereas an infant may start off with gross irritability and feeding difficulty.

An inflammatory reaction of meninges may produce some meningeal signs.

Clinical picture shows rapid variation from hour to hour. Confusing neurologic involvements, including tremors and sensory changes, may be observed. Hemiparesis is common; so, are respiratory irregularities. Visual disturbances and facial paralysis occur in some cases. Occasionally, myocarditis and hypotension complicate the picture.

In a number of conditions that could fall under the title *progressive encephalopathy*, the child exhibits some degree of mental retardation (Table 23.9).

- iii. *Anticonvulsants* Convulsions should be controlled with phenobarbital, paraldehyde, chloral hydrate, diazepam, lorazepam or diphenylhydantoin sodium. Most cases need anticonvulsant therapy round the clock.
- iv. *Reduction of hyperpyrexia* High fever should be controlled by tepid sponging and/or antipyretics.
- v. *Reduction of intracranial pressure* This is achieved by careful repeated withdrawal of CSF or with hypertonic solutions like mannitol given intravenously.
- vi. *Maintenance of airway* Frequent suctioning is usually sufficient. Some cases may require tracheostomy and even assisted respiration by a "respirator".
- vii. *Corticosteroids* Most authorities feel that the benefit of steroid therapy should be given. The true value of such a therapy is not established.
- viii. *Human immunoglobulin* There is some evidence that IVIG, when given early enough and in high-dose (200 to 500 mg/kg), may considerably reduce the mortality rate.

Prognosis

It is always guarded. Recently, low serum and CSF magnesium level in acute encephalitis have been found to be associated with prolonged illness and poor prognosis*. The mortality rate is high. Those who survive may be left with sequelae like mental retardation, epilepsy, behavioral disorders, obesity and paralysis.

HYDROCEPHALUS

The Greek term, "hydrocephalus", literally meaning water logging of the head, refers to the enlargement of the head as a result of abnormally high accumulation of CSF in the intracranial spaces. Whereas incidence of congenital hydrocephalus is not precisely known, acquired hydrocephalus occurs 1 in 1,000 children.

Before embarking on details about hydrocephalus, let us recall the circulation of cerebrospinal fluid

(CSF). It is the choroid plexus (predominantly that of lateral ventricles) that secretes the CSF. From there, the CSF passes through the foramina of Monro to the third ventricle and then via aqueduct of Sylvius to fourth ventricle. Through foramina of Luschka and Magendie in the roof of the fourth ventricle, it enters the into the subarachnoid spaces. Only 20% of it enters the spinal subarachnoid space. The overwhelming amount goes to the subarachnoid villi near the sagittal sinus where it gets absorbed.

Etiology

It may be because of:

- Increased production (*communicating hydrocephalus*), e.g. pseudotumor cerebri, choroid plexus papilloma.
- Obstruction to the flow (*noncommunicating hydrocephalus*), e.g. inflammatory adhesions, developmental obstructive lesions.
- Interference with absorption, e.g. cavernous sinus thrombosis.

Majority of the patients suffer from the second type, i.e. obstruction in route of CSF flow. Increased production is less frequent. Interference with absorption of the fluid is uncommon and also of poorly understood mechanism. Clinically, the causes are:

I. Congenital Hydrocephalus

It may be associated with:

- *Arnold-Chiari malformation* in which there is a displacement of the brainstem and cerebellum, through foramen magnum, into upper cervical part of the spine. It is generally associated with spina bifida and meningomyelocele.
- *Dandy-Walker anomaly* in which congenital septa or membranes block the outlet of the fourth ventricle.
- Malformations or stenotic lesions of aqueduct cerebri.
- Malformations of arachnoid villi.

II. Acquired Hydrocephalus

- *Inflammatory* Meningitis, occasionally encephalitis in first few months of life.
- *Traumatic* Birth trauma, head injury, intracranial hemorrhage.

* This observation holds good for meningitis, both tuberculous and pyogenic, as well

- *Neoplastic* Space-occupying lesions like tuberculoma, subdural hematoma or abscess, gliomas, etc.
- *Chemical* Hypervitaminosis A.
- *Connective tissue disorders* Hurler syndrome, achondroplasia.

Clinical Features

Congenital hydrocephalus is present right at birth or becomes apparent in the first few month of life.

Acquired hydrocephalus develops later, in association with or as a sequel to the causative factor.

Clinical picture is classical with a large head, wide and bulging fontanels, open sutures, protruding forehead and dilated, prominent scalp veins. Scalp appears thin and shiny. The *sun-set sign*, i.e. visible sclera above the cornea, is characteristic (Fig. 23.19). The *cracked-pot* (Macewen) *sign* may be elicited by percussing the head. A resonant note as a result of separation of sutures is present. Transillumination is positive.

With steady rise in intracranial pressure, the cry becomes shrill.

Mental faculty and other neurologic manifestations vary with the causative and associated factor(s). Many are known to have fairly normal intelligence.

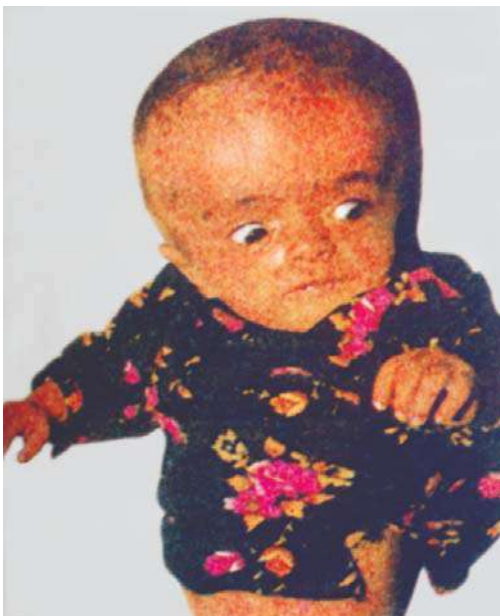

Fig. 23.19: *Congenital hydrocephalus*. Note the “sunset” sign in the eyes in addition to enlarged head (43 cm) in this neonate

Arrested hydrocephalus is the term applied when there is no more progression in the head size. This type requires no surgical intervention.

Hydrocephalus occurring late in childhood is not accompanied by big head. Instead there occur manifestations of raised intracranial pressure such as papilledema, spasticity, ataxia, urinary incontinence, and progressive deterioration in mental faculty.

Diagnosis

It is easy to diagnose hydrocephalus. But the aim should be to find out the exact lesion. That may need extensive radiologic studies of the skull, including ventriculography and pneumoencephalography.

CT scan (or MRI) along with ultrasound are the most reliable and safe tool in identifying the site of obstruction in the CSF flow.

Differential diagnosis is primarily from megalencephaly or hydraencephaly, chronic subdural effusion or hematoma, cerebral atrophy, and thickened cranium due to rickets, chronic anemia, osteogenesis imperfecta, and epiphyseal dysplasia.

Treatment

Medical treatment, aimed at reducing the raised intracranial pressure with hypertonic solutions (mannitol), acetazolamide, frusemide or other diuretics, is, at best, of temporary value.

Firm wrapping of the head and third *ventriculos-tomy* and *choroid plexectomy* have been employed with variable results.

Surgical shunts, using tubes which bypass the obstruction and drain the excess CSF to the exterior (ureter, blood, pleural, peritoneal or some other cavity, or into the right atrium), are the treatment of choice at the present time.

Prognosis is, however, not uniformly good. Sepsis of the shunt, usually with *staphylococcal epidermidis*, and obstruction are the major complication. Pulmonary hypertension and cor pulmonale may well result following this operation as long-term complications.

Intrauterine surgical intervention in fetal hydrocephalus that is frequently accompanied by cerebral malformations has not yet given good results.

Prognosis

Following appropriate medical and neurosurgical treatment, about 70% of patients with infantile hydrocephalus live beyond first year of life. Around 60% of these are likely to have motor and intellectual handicap in the form of low IQ, poor memory, visual problems (squint, field defects, optic atrophy), and aggressive and delinquent behavior. A long-term follow-up in a multidisciplinary setting is warranted.

Without treatment, mortality is as high as 50 to 60%.

INTRACRANIAL SPACE-OCCUPYING LESIONS (ICSOL)

Intracranial abnormal lesions, causing raised intracranial pressure and pressure symptoms, are:

1. *Inflammatory* Tuberculoma, brain abscess, subdural effusion.
2. *Traumatic* Subdural hematoma.
3. *Parasitic* Cysticercosis, hydatid disease.
4. *Tumors* Astrocytoma, medulloblastoma, glioma, ependymoma, choroid plexus papilloma, craniopharyngioma.

BRAIN ABSCESS

Etiopathogenesis

It may result from:

- As a complication of otitis media, mastoiditis, sinusitis or infection of the skull bones,
- Hematogenous spread of suppurative conditions such as lung abscess, empyema or bronchiectasis,
- Generalized pyemia as in bacterial endocarditis, and
- Cyanotic congenital heart disease in which the septic emboli find it easy to pass through the right to left shunt and then find a good medium for the growth of the organism in the hypoxic brain tissue.

The causative organisms include anaerobic bacteria, *Streptococcus aureus*, *pneumococcus*, *H. influenzae*, proteus, klebsiella, etc. Infrequently, fungus and amebic infections may also be responsible for the disease.

The most common location of the abscess is the cerebellum. When it is in the cerebrum, the site is usually in the temporal or frontal lobe.

It usually begins as a focal suppurative encephalitis. Subsequently, a protective wall develops

around the suppuration. Pathologically, the abscess is a layer of vascularized granulation tissue encapsulating pus and other glial cell proliferation.

Clinical Features

The increased intracranial pressure may cause headache, vomiting and visual disturbances.

Depending on the location of the abscess, there may be focal neurologic manifestations such as convulsions, cranial nerve palsies, ataxia, visual field defects, hemiparesis, etc.

Manifestations of toxemia may include high or low irregular fever, chills, rigors and leukocytosis.

As a result of intracranial suppuration, the child may have irritability, behavior problems, drowsiness, and loss of weight.

Diagnosis

It is primarily by clinical suspicion from the presenting features in a susceptible case. It is important to demonstrate evidence of pyemia and leukocytosis. ESR may be slightly high. Lumbar puncture is best avoided in the presence of papilledema because of the danger of herniation and coning of the brainstem. EEG may be of help in localizing the abscess.

Confirmatory investigations are arteriography and CT scan (Figs 23.20 and 23.21).

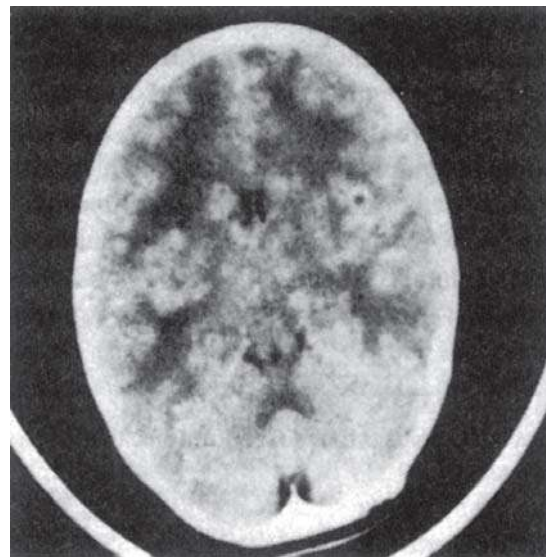

Fig. 23.20: CT scan showing cerebral abscess in left frontal lobe



Fig. 23.21: CT scan showing multiple brain abscesses

4

Treatment

Besides general measures, including hectic antibiotic therapy, treatment is surgical drainage or excision of the abscess.

SUBDURAL EFFUSION

Subdural effusion usually occurs in infants as a complication of pyogenic meningitis (in most cases due to *H. influenzae* or *Pneumococcus*). The usual site is frontal or parietal region.

The effusion is generally small. Such small effusions may be multiple and, as a rule, clear spontaneously.

Large effusions are likely to cause raised intracranial pressure and interfere with recovery from meningitis.

Manifestations include persistent fever, vomiting, convulsions, irritability or drowsiness, tense and bulging anterior fontanel and progressively increasing hydrocephalus in a case of pyogenic meningitis on adequate therapy. CSF usually continues to be abnormal. Skull sutures may be separated. Increased transillumination of the head may be observed.

Once the existence of subdural effusion is suspected, a subdural tap should immediately be done. See Chapter 43 for technique.

Treatment consists in tapping a large effusion daily or on alternate days. Its persistence beyond 2 weeks, despite such taps, is an indication for surgical drainage after craniotomy.

SUBDURAL HEMATOMA

Acute subdural hematoma, a common conditions in infancy with a peak incidence at 6 months, is invariably due to trauma during birth or later. The predisposing causes include congenital malformations of blood vessels, malnutrition, dehydration and bleeding diathesis. The condition is usually bilateral. The common site is frontal or parietal region.

Manifestations include progressive deterioration in consciousness, focal convulsions and neurologic signs. Sluggishly-reacting, dilated and unequal pupils, ptosis, squint, facial paralysis, contralateral hemiplegia, meningeal signs, bulging and tense anterior fontanel, hydrocephalus with sutural diastasis and decerebrate rigidity may occur.

Investigations may show papilledema and retinal hemorrhages, unilateral bulging of skull and sutural diastasis on radiology and frank blood in the subdural tap which is the most useful tool. Arteriography and radioisotope brain scan may be of helpful. CT scan may be needed to confirm the diagnosis.

Treatment is repeated drainage of the blood by subdural tap over a period of 2 weeks, or by irrigation through burr holes, and surgical excision of the hematoma.

Subacute subdural hematoma, unlike the acute one, does not manifest immediately after the injury. It takes a few days to do that.

Chronic subdural hematoma usually follows birth injury or postnatal head trauma. It is particularly more common in preterm babies.

Manifestations, produced usually about 2 weeks after the trauma, include failure to thrive, irritability, vomiting, fever, drowsiness, convulsions, wasting, bulging fontanel and enlargement (biparietal) of head. Focal neurologic signs are usually not encountered, except in older children in whom papilloedema and hemiparesis may be present.

Diagnosis is confirmed by subdural tap and radiology, including pneumoencephalography. EEG and angiography may be helpful in difficult situations.

Treatment consists in draining the hematoma by repeated subdural taps and removing the blood by surgical evacuation, if the response to the former is poor.

NEUROCYSTICERCOSIS

Neurocysticercosis is the most common cause of parasitic CNS disease.

Etiopathogenesis

It is a sort of granuloma, representing intermediate (granulomatous) stage of the pork tapeworm, *Tenia solium*. The cysts are either solitary or multiple, varying from 0.2 to 0.5 cm in diameter. Symptoms result from cerebral lesion(s) or obstruction to flow of the CSF.

Clinical Features

Manifestations include varying symptoms from psychosis through seizures to stroke. Seizures are the most frequent, the incidence being around 70 percent in affected children. Seizures are, as a rule, generalized but may well be simple or complex partial. Clinically, differential diagnosis is from CNS tuberculosis, encephalitis, stroke, etc.

Diagnostic Investigations

Specific diagnostic investigations include neuroimaging studies, the most important being CT scan and/or MRI. A single enhancing ring or disc-like lesion, usually in the parietal region, that is hypodense with irregular margins and an eccentric dot (scolex) is a pathognomonic sign of neurocysticercosis (Fig. 23.22). The MRI scores over CT scan in detecting scolex, in delineating evidence of inflammation around the cyst, for intraventricular cysts and for spinal cord cysts. Diffuse or disseminated cysticercosis may show up as the “starry-night” appearance (Fig. 23.23).

Enzyme-linked immunotransfer blot (ELTB) is a highly specific and sensitive serologic test for cysticercosis.

Treatment

Specific therapy is indicated only for active and/or disseminated neurocysticercosis and is in the form

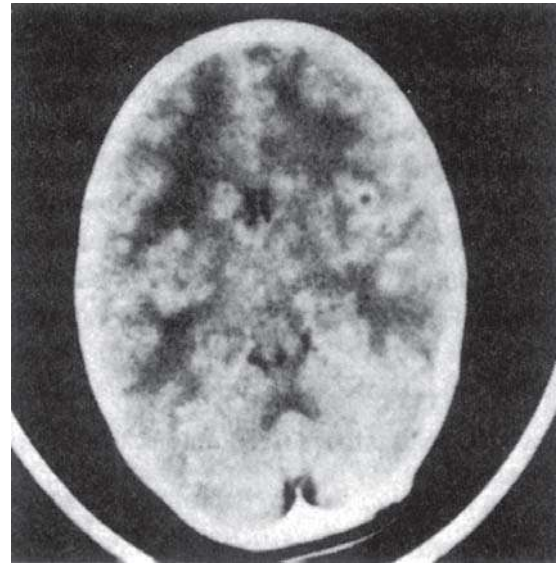

Fig. 23.22: CT scan (contrast enhanced) showing a single ring-shaped lesion right parietal lobe



Fig. 23.23: CT scan showing disseminated (diffuse) neurocysticercosis. Note the “starry-night” appearance

of albendazole, 15 mg/kg/day for 28 days (even as short a course as of 5 days may prove effective), or, in case of its failure, praziquantel (PZQ), 50 mg/kg/day for 15 days. To safeguard against worsening of symptoms due to enhanced inflammatory response following specific therapy, it is advisable to give steroid therapy for 2 to 7 days, starting a few days prior to actual institution of specific therapy. Dose of PZQ needs to be 100 mg/kg/day in this case.

Surgical intervention is indicated in ocular cysticercosis and in placing a ventricular shunt prior to specific therapy of ventricular or spinal disease or parenchymal lesions with hydrocephalus.

INTRACRANIAL TUMORS

Tumors are the most common cause of abnormal increase in head size after 2 years of age. A great majority of them are gliomas which are nearly always found in the posterior fossa. The most frequently occurring tumor, *astrocytoma*, is slow-growing and relatively mild. The next in frequency, i.e. *medulloblastoma*, is highly malignant. For details, see Chapter 28 (Pediatric Oncology).

CAVERNOUS SINUS THROMBOSIS

4 Etiopathogenesis

This uncommon condition occurs as a complication of a septic focus over face, orbit, nose, teeth, etc. The infection spreads from facial veins to ophthalmic vein and finally to the cavernous sinus. Intracranial extension may be accompanied by meningitis.

Clinical Features

These include high spiking fever, rigors, drowsiness, swelling of affected eye with proptosis, chemosis, prominent veins over lids and ophthalmoplegia involving 3rd, 4th, 5th and 6th cranial nerves (Fig. 23.24). Pupillary reflexes may be absent and there may be visual defects with, at times, total



Fig. 23.24: Cavernous sinus thrombosis. The child presented with hyperpyrexia, swollen eyes with proptosis, and ophthalmoplegia

blindness. Fundoscopy reveals blurred disc margins and engorged retinal veins.

Diagnosis

It is more or less clinical. Orbital cellulitis with localized manifestations is an important differential diagnosis. LP is indicated in a case of doubtful meningitis. Slight rise in CSF proteins may be seen in cavernous sinus thrombosis without meningitis.

Treatment

It consists in giving high-dose parenteral antibiotic therapy, providing a good cover for *Staphylococcus aureus*, and anti-inflammatory therapy. Drainage of pus from primary septic focus needs to be given a priority.

Supportive measures, including mannitol for raised intracranial tension, are indicated.

Anticoagulant therapy is no longer recommended.

CRANIOSYNOSTOSIS (*Craniostenosis*)

The premature closure of the skull sutures, leading to interference with the proper brain growth, is termed *craniostenosis* or, to be more exact, *craniosynostosis*. One or more sutures may be involved. Since the stiff skull vault does not allow the brain to grow, a kind of situation resembling raised intracranial tension results. It may well be a genetic disorder.

Classification

Depending on the suture or sutures involved, the following cranial deformities may result.

- *Oxycephaly* This means fusion of coronal and, in some cases, all the sutures. The head may be anteroposteriorly flattened and elongated transversely and upwardly (Figs 23.25 and 23.26). This is called acrocephaly. When all the sutures are fused, head is symmetrically microcephalic.
- *Scaphocephaly* Here, the sagittal suture is fused. As a result, skull grows anteroposteriorly and thus assumes an elongated appearance resembling a boat (Fig. 23.27). Hence, the name, scaphocephaly is the most common type of craniostenosis, accounting for around one-half of the cases.
- *Plagiocephaly* Asymmetrical fusion of suture(s) leading to asymmetrical skull.



Fig. 23.25: Oxycephaly



Fig. 23.26: Craniosynostosis. Note the oxycephaly

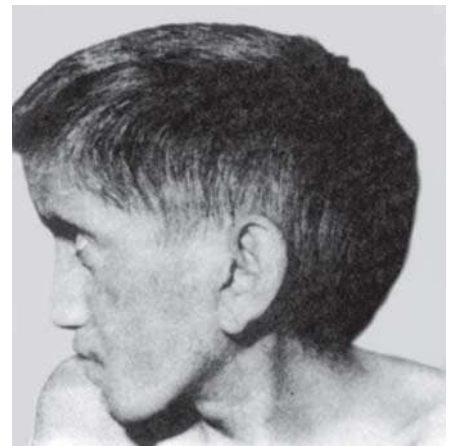

Fig. 23.27: Scaphocephaly. Note the boat-shaped head

Clinical Features

The symptomatic subjects have manifestations secondary to high intracranial tension. These include headache, vomiting, proptosis, squint, convulsions, hyperreflexia, hypertonia and mental retardation.

Physical examination reveal typical appearance. Concerned sutures are united and the fontanels closed. The signs of neurologic deficit may be present.

Craniosynostosis has been reported in association with other anomalies like arachnodactyly and Turner syndrome. In *Apert syndrome*, oxycephaly is accompanied by syndactyly. When a child with oxycephaly has beaked nose, proptosis and hypertelorism, the combination is known as *craniofacial dysostosis* or *Crouzon's disease* (Figs 23.28 and 23.29). In *Carpenter syndrome*, there is acrocephaly, syndactyly in the hands, polydactyly and syndactyly in the feet, and tendency for mental retardation. The syndrome has recessive inheritance.

Diagnosis

Clinical appearance is so characteristic in a large majority of the cases that no investigation may indeed be needed. Palpation reveals a ridge along the involved suture and prematurely closed fontanels. X-ray skull confirms the closure of suture(s). When craniosynostosis is of severe degree with marked and prolonged rise of intracranial pressure, distinct impressions on the skull vault, the *silver-beaten appearance*, are seen in the X-ray film (Fig. 23.30).



Figs 23.28 and 23.29: Crouzon disease. Note the oxycephalic head, proptosis, beaking of the nose and hypoplastic maxilla

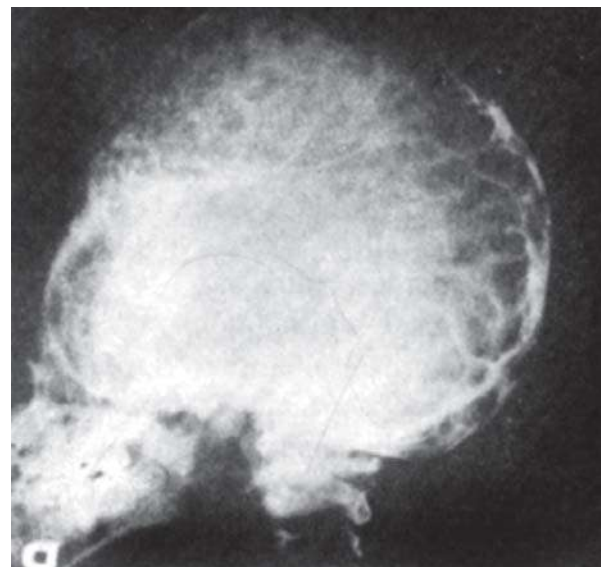

Fig. 23.30: Skull X-ray in craniosynostosis. Note the oxycephalic skull with silver-beaten appearance

Treatment

Surgical intervention should be done at the earliest to prevent occurrence of mental retardation and other neurologic effects of raised intracranial pressure. It consists in making artificial sutures.

CONVULSIVE DISORDERS

A convulsion or seizure is a transient disturbance of brain function, manifested by involuntary motor, sensory, autonomic or psychic phenomenon—alone or in any combination—usually having associated alteration of loss of consciousness.

Convulsions are relatively more common in infancy and childhood. The overall incidence in childhood is stated to be 8%, among mentally retarded children (except those with Down syndrome) 20%, and among those suffering from cerebral palsy 35%. In a recent retrospective study we found an overall incidence of 15% among inpatients and 11% among outpatients.

Convulsions may be categorized in terms of causes according to the age of onset as shown in Table 23.10.

FEBRILE SEIZURES

The term denotes seizures associated with fever but excluding those due to CNS infections.

Incidence

It is one of the most common disorders of infancy and early childhood. We found an incidence of 6% in infants and children attending the Well Baby Clinic of the Snowdon Hospital, Simla. This figure is little higher than those reported from the West.

The experience shows that boys are affected nearly twice as frequently as girls. According to a conservative estimate, febrile convulsions account for 50% of all convulsive disorders of pediatric age group.

Special Features Some of the remaining salient features are:

A. Typical (Simple) Febrile Seizures

- These are generally associated with fever of 38°C or more at the time of attack.
- Generalized rather than focal convulsions are nearly a rule.
- The first febrile seizure usually occurs between 6 months and 3 years of age.

Table 23.10: Causes of convulsions according to age of onset

A. 0 to 1 Month

First and Second Day: Perinatal problems such as birth injury, asphyxia, hypoxia, intracranial (especially intraventricular) hemorrhage: drug (narcotic) withdrawal; pyridoxine dependency; accidental injection of anesthesia into an infant's scalp during labor; inborn errors such as phenylketonuria (PKU).

Third day: Hypoglycemia.

Fourth day and Onward: Infections like meningitis, septicemia, hypocalcemia (tetany), hypo- or hypernatremia, hypomagnesemia, kernicterus, tetanus, congenital malformations like arteriovenous fistula, porencephaly, intrauterine infections like syphilis, toxoplasmosis, rubella, cytomegalic inclusion disease, herpes simplex (STORCH).

B. 1 to 6 Months

CNS Infections: Meningitis, encephalitis, enteric fever, cerebral malaria, intrauterine infections.

Metabolic: Hypoglycemia, hypocalcemia, hypernatremia, hypomagnesemia, inborn errors of metabolism like glycogen-storage disease, kinky hair syndrome.

Traumatic: Nonaccidental injury, chronic subdurals.

Congenital malformations: Arteriovenous fistulae

Space-occupying: Brain tumor, abscess, tuberculoma, cysticercosis

Vascular: Intracranial hemorrhage, DIC, hypertension

Drugs: Phenothiazines, strychnine, piperazine, lead

Postvaccinal: DPT

C. 6 Months to 3 Years

Febrile convulsions plus previously enumerated conditions at B

D. 3 to 6 Years

Idiopathic epilepsy; febrile convulsions uncommon; rest as previously enumerated at B.

- Family history of seizures is frequently present. Also, higher incidence occurs in twins and children of consanguineous parents. This has led to the speculation that, as a result of genetic susceptibility, immature neuronal membrane responds to the temperature elevation by breaking down.
- The attack lasts less than 10 to 20 minutes
- There is no recurrence before 12 to 18 hours of the attack that accompanies rapid rise in body temperature.
- There is no residual paralysis of a limb following the attack.
- CSF after the attack is normal.
- EEG after the attack is normal.

B. Atypical (Complex) Febrile Seizures

A proportion of children may have focal convulsions of greater than 20 minutes duration even without significant fever, and/or with persistently abnormal EEG for two weeks or more after the attack. All these cases (in fact all cases of febrile seizures not satisfying the criteria laid down for typical febrile seizures) are labelled “atypical” febrile convulsion cases. They are basically predisposed to idiopathic epilepsy.

Treatment

Treatment consists in controlling the seizures, bringing down the fever and treating the cause of high temperature which is usually a respiratory infection.

An anticonvulsant is indicated in the event of a prolonged attack (exceeding 3 minutes). *Phenobarbital*, 5.0 mg/kg (IM) or *diazepam* 0.3 mg/kg (IV) or 0.5-1 mg/kg (R) with a maximum of 10 mg usually suffices. Rectal diazepam has the advantage that it can be administered by paramedical staff and even by parents at home. It is now available in India (Direct 2) as a kit enclosing a colored bottle providing 25 ml of 2 mg/ml diazepam solution, a 5 ml syringe and 10 disposable adopters.

Reduction of body temperature may be achieved by tepid water sponging and/or antipyretics like paracetamol, mefenamic acid, ibuprofen or nimisulide.

Prophylaxis

Whereas parents must be advised to employ antipyretic measures as and when the body temperature is likely to shoot up in all cases of febrile seizures, long-term anticonvulsant therapy is not needed for “typical” cases. Drug prophylaxis is usually needed in complex seizures.

Intermittent: Diazepam, lorazepam or midazole (even clonazepam or clobazan), given orally during first 3 days of fever, is the preferred modality.

Continuous: Oral phenobarbital (3-5 mg/kg/day) or sodium valproate (10-20 mg/kg/day), given for 1-2 years or until 5 years of age (whichever is earlier), is recommended for subject who fail to respond to intermittent prophylaxis. Its other indications are CNS disease (say mental retardation), recurrent

complex febrile seizures and positive family history of epilepsy.

Prognosis

It is very good in typical febrile seizures. In atypical variety, outcome is less gratifying with high incidence of intellectual impairment, behavior disturbances and epilepsy.

CHRONIC/RECURRENT CONVULSIONS

Under this heading are covered epilepsy, epilepsy-simulating states and epilepsy equivalents such as narcolepsy, hysteria, breath-holding spells, syncope and migraine.

Epilepsy is defined as a symptom-complex characterized by recurrent, paroxysmal attacks of unconsciousness or impaired consciousness, usually with a succession of tonic or clonic muscular spasms or other abnormal behavior. It may be idiopathic or organic.

The salient details of types of *idiopathic epilepsy* are given below:

- *Grand mal* Most common; generalized tonic-clonic convulsions are its hallmark
- *Petit mal* Momentary loss of consciousness.
- *Jacksonian or focal* Seizures starting from one part and spreading to other parts in a fixed pattern.
- *Psychomotor (temporal lobe)* Visceral symptoms like nausea, vomiting or epigastric sensations followed by short periods of increased muscular tonicity and, later, semipurposive movements during a period of impaired consciousness or amnesia. The syndrome of periodic headache in association with abdominal pain, nausea and vomiting has been termed *abdominal epilepsy* or *abdominal migraine*.
- *Myoclonic* Involuntary violent contractions of limbs or groups of muscles with or without loss of consciousness. In infantile myoclonic epilepsy, also called *salaam seizures* or *West syndrome*, the baby (usually under 6 months) has massive attacks of flexion of the head, once or as many as 100 times a day. In the primary type child is microcephalic and mentally retarded. EEG shows typical hypsarrhythmia. Treatment is preferably with ACTH though steroids, diazepam, valproate and pyridoxine may also prove effective. Prognosis is not good.

Organic epilepsy is frequently accompanied by cerebral palsy, mental retardation and EEG abnormalities. Its main causes are:

Posttraumatic Direct damage to brain tissue as following head injury.

Posthemorrhagic Injury to brain at birth or afterwards, bleeding diathesis, rupture of miliary aneurysm, pachymeningitis.

Postinfectious Meningitis, encephalitis, cerebral abscess, sinus thrombophlebitis.

Posttoxic Kernicterus, chronic poisoning (lead, arsenic).

Degenerative Intracranial neurofibromatosis, cerebromacular degeneration, subacute sclerosing panencephalitis.

Congenital Arteriovenous aneurysm, Sturge-Weber type of vascular anomaly, cerebral aplasia, poren-cephaly, hydrocephalus, tuberous sclerosis

Parasitosis Cysticercosis, hydatid disease, ascariasis, toxoplasmosis.

Table 23.11 presents the new international classification of epileptic seizures. The old terminology wherever it is at variance is given in brackets.

Table 23.11: New international classification of convulsions

Partial Seizures

IV. *Simple*

- With motor signs (Jacksonian or focal motor)
- With somatosensory or special sensory i.e. visual, auditory, olfactory, vertiginous, gustatory, symptoms (sensory seizures)
- With autonomic manifestations (abdominal epilepsy, epileptic equivalent)

II. *Complex*

Generalized Seizures

I. Absence seizures

- Typical (Petit mal)
- Atypical (Petit mal variant or complex Petit mal)

II. Myoclonic seizures

III. Atonic seizures (akinetic seizures or drop attacks)

IV. *Tonic-clonic seizures (grand mal, major motor seizures, generalized convulsive seizures)*

STATUS EPILEPTICUS

By definition, *status epilepticus* means any true convulsion lasting more than 30 minutes, or a series of convulsions extending over such a period, with or without recovery of consciousness between spells.

This implies that loss of consciousness, though a prominent feature of status epilepticus with grand mal epilepsy, may be absent in Petit mal, psychomotor or myoclonic status. In the latter category, consciousness is generally only impaired. Status convulsivus refers to status epilepticus with preservation of consciousness.

An important feature of the treatment of status epilepticus is the prompt institution of vigorous initial therapy rather than small doses of various anticonvulsant drugs.

At times, recovery from status may be followed by weakness of a limb or two for 12 to 24 hours (or infrequently a week or so). Resolution is slow but, as a rule complete. However, occasionally, minimal weakness may persist. This is what is called *Todd paresis*. This "postictal paralysis" was believed to be due to metabolic exhaustion of epileptic neurons. Today it is regarded to be a sequel to persistence of active inhibitory state which produces clonic phase of the seizures.

DIAGNOSIS OF CONVULSIVE DISORDERS

Most cases of convulsion can be clinically categorized to the various etiologic groups. A detailed history and physical examination are, therefore, very rewarding. Fundoscopy and lumbar puncture should always be done after the acute attack has been brought under control. Blood sugar and calcium levels may be helpful if hypoglycemia (usually during neonatal period) and tetany are suspected. Besides X-ray skull, pneumoencephalography, arteriography and radioisotope brain scan may be of value, especially in cases of persistent localizing signs.

EEG is a useful investigation and should be done in doubtful cases. In *Petit mal epilepsy*, for instance, 3 per second spikes and wave complexes are diagnostic.

DRUG THERAPY OF AN ACUTE CONVULSIVE EPISODE/STATUS EPILEPTICUS

A large number of drugs are available (Table 23.12). The best is *diazepam*, 0.3 mg/kg, intravenously, stat. Half of this dose may be repeated in 10 to 20 minutes, if necessary. Since the action of diazepam lasts just 1/2 to 1 hour, it should be followed by maintenance dose of phenobarbital, 3 to 5 mg/kg/day, to protect against recurrences. For control of acute attack, if

Table 23.12: Drugs employed in acute convulsive episode/status epilepticus

Diazepam	0.3 mg/kg/dose (IV) 0.5 - 1 mg/kg/dose (PR) or 1 mg/yr/dose + 1 mg (IV) Maximum single dose 10 mg given slowly in 2 to 3 minutes
Phenobarbital	5 to 10 mg/kg/dose (IV) Given slowly in 2 to 3 minutes
Paraldehyde	0.15 ml/kg/ dose (IM, IV) or 0.5 to 1 ml/yr/dose (IV)
Phenytoin	15 to 20 mg/kg/dose (IV) Given slowly in 15 to 20 minutes

diazepam is not available, drugs like injectable phenobarbital, paraldehyde, diphenylhydantoin or chloral hydrate may be used.

LONG-TERM DRUG THERAPY

Though quite a few drugs are available, for long-term drug therapy of grand mal epilepsy, *phenobarbital* alone or together with *diphenylhydantoin sodium* in divided doses, usually suffices. Side-effects of long-term administration of phenobarbital include behavioral problems, hyperactivity, irritability, quarrelsomeness and sleep disturbances. Since the problems become quite troublesome in some instances, a substitute drug is often given sooner or later. Carbamazepine, though expensive, is of special value in grand mal epilepsy, and temporal lobe seizures to counter the usual problem of psychosomatic deterioration.

For Petit mal epilepsy, ethosuximide is the drug of choice in view of the serious toxicity of trimethadione.

Sodium valproate claims superior efficacy in grand mal, Petit mal, temporal lobe and mixed epilepsies.

Long-term anticonvulsant therapy is continued for about 4 years of seizure-free period. The drug(s) should never be withdrawn abruptly. Instead, the dosage should be tapered gradually over a period of some months. This can be done clinically without obtaining help from EEG (Table 23.13).

Table 23.13: Drugs commonly employed in recurrent convulsions

Phenobarbital	3 to 5 mg/kg/day in 1 or 2 divided doses
Diphenylhydantoin	5 to 8 mg/kg/day in 2 divided doses
Carbamazepine	10 to 20 mg/kg/day in 2 or 3 divided doses
Sodium valproate	15 to 20 mg/kg/day in 3 or 4 divided doses
Ethosuximide	10 to 20 mg/kg/day in 2 divided doses
Clonazepam	0.01 to 0.3 mg/kg/day in 3 divided doses

INTRACTABLE SEIZURES

The term refers to a group of subjects who fail to respond to usually effective anticonvulsant therapy given in maximum tolerated dosage (therapeutic and even suprathreshold range). The incidence is around 25% of all children with epilepsy. Most important factor contributing to intractability is the noncompliance in some form.

Common epilepsies likely to become intractable include complex partial seizures, myoclonic seizures, neonatal myoclonic encephalopathy, early infantile epileptic encephalopathy, West syndrome, Lennox Gastaut's syndrome, epilepsy with myoclonic absences, severe myoclonic epilepsy of infancy, and progressive myoclonus epilepsy.

Diagnostic evaluation should include re-evaluation of history and examination, patient's compliance and drug-drug interaction, determination of drug levels periodically, MRI, PET or SPECT scanning, and prolonged EEG video monitoring. The last is especially useful when pseudoseizures/other nonepileptiform disorders are on the card.

Treatment is with high dose (at times even supra-therapeutic) monotherapy. Five major drugs, namely phenobarbital, phenytoin, carbamazepine, primidone and valproic acid may be tested. In case seizures still remain uncontrolled, two first line drugs can be combined or, alternatively, add another anticonvulsant like metha-suximide, ethosuximide, or acetazolimide. If the second drug too fails to work, yet another can be tried (Table 23.14).

Surgical therapy is indicated when medical therapy fails or is accompanied by untoward side-effects. It may be in the form of resection (say lobectomy) or palliative procedure (say corpus callosotomy).

Table 23.14: Anticonvulsant choice based on seizure type in intractable/refractory epilepsy

Seizure type	First choice	Other options
Generalized		
Infantile spasm	Corticotropin	Topiramate, zonisamide, vigabatrin
Absence	Ethosuccimide	Valproate, lamotrigine, zonisamide
Atonic	Valproate	Topiramate, lamotrigine, phenytoin, phenobarbitone, zonisamide, felbamate
Tonic	Valproate	Topiramate, lamotrigine, phenytoin, phenobarbitone, zonisamide, felbamate
Myoclonic	Valproate	Topiramate, lamotrigine, phenytoin, phenobarbitone, zonisamide, felbamate
Tonic-clonic	Valproate	Topiramate, lamotrigine, phenytoin, phenobarbitone, zonisamide, felbamate
Partial Generalized or not	Carbamazepine	Oxcarbazepine, lamotrigine, topiramate, phenytoin, levetiracetam, zonisamide, tiagabine, gabapentin, valproate, phenobarbitone, felbamate

INFANTILE TREMOR SYNDROME (ITS)

Tremors are a leading manifestation of ITS, the other features being significant anemia, kwashiorkor-like hair changes and regression of developmental and mental milestones. Tremors are distal in the beginning but, as the condition worsens, these involve the whole body. Their site of origin seems to be “cortical”. For details, see Chapter 42.

REYE SYNDROME

This syndrome of acute encephalopathy with fatty degeneration of the liver may be confused with several disorders (the so-called “Reye-like” diseases) such as CNS infections (meningitis, encephalitis), CNS intoxications (toxic encephalopathy), metabolic diseases (systemic carnitine deficiency), hemorrhagic shock with encephalopathy, drug toxicity (salicylates, valproate) and toxins (hypoglycin A, valproate). For details, see Chapter 25.

PHAKOMATOSES

(Neurocutaneous Syndromes)

Tuberous sclerosis (Bourneville disease) is an autosomal dominant disorder involving multiple systems. Clinical manifestations include mental retardation, epilepsy and multiple cutaneous stigmata (white leafy macule, adenoma subaceum). Benign tumors (tubers) are found in such organs as brain (visible as characteristic calcification on skull X-ray), kidneys, fundi (retinal phakomas), heart (rhabdomyoma), bones (areas of sclerosis and rarefaction on X-ray), lungs, liver and spleen.

Neurofibromatosis (von Recklinghausen disease), another autosomal dominant neurocutaneous disorder, is characterized by cafe-au-lait spots (irregular hyperpigmented areas: more than 6 spots, each measuring at least 1.5 cm), axillary freckling (*Crowe sign*) and speckled hyperpigmentation and, later in childhood, neurofibromas involving skin, subcutaneous tissue, oral mucosa, musculoskeletal system, GIT, eyes, and CNS leading to a variety of manifestations. Incidence of congenital malformations and neural tumors, such as pheochromocytoma, meningioma and glioma of optic chiasma and nerve, and sarcomas is increased. Mental retardation, though mild, is a common accompaniment.

Sturge-Weber disease, a nonfamilial disorder, results from a unilateral congenital capillary hemangioma involving face and neck (facial nevus, involving usually ophthalmic division of trigeminal nerve), mucous membrane, meninges and choroid plexus. Neurologic manifestations include seizures, mental defect, hemiparesis or hemianopsia, rarely subarachnoid hemorrhage, glaucoma, and railroad track pattern of calcification on X-ray skull.

von Hippel-Lindau disease is characterized by visual loss and manifestations related to cerebellar or spinal cord dysfunction. The basic lesion is angioma of retina, usually accompanied by hemangioblastoma of cerebellum, hemangioma of spinal cord, hypernephroma and cystadenomas of viscera may occur but are less frequent. Paradoxically, skin is not involved. This condition appears at adolescence or later.

Ataxia telangiectasia, a defect of embryogenesis, is characterized by cerebellar ataxia, ocular and cutaneous telangiectasia, chronic sinopulmonary infection, endocrinal abnormalities and immunodeficiency of B and T cell (most frequently IgA and

IgE deficiency, singly or together). All subjects demonstrate presence of alpha-fetoprotein, carcinoembryonic antigen. Inheritance is as autosomal trait of presumably recessive type. Because of faulty DNA repair mechanism. X-ray exposure must be avoided in the subjects with this condition. Death follows lymphoreticular malignancy with the worsening of the T cell deficiency, or resistant infection.

Linear nevus syndrome, a sporadic condition, is characterized by a facial nevus over middle of and forehead and nose and neurodevelopmental defects. Usual accompaniments include mental retardation, seizures (generalized myoclonic or focal motor), and focal neurologic signs including hemiparesis and hemianopia (homonymous).

Incontinentia pigmenti (Bloch-Sulzberger disease), an X-linked dominant disorder, lethal to the males, is characterized by multisystem involvement. CNS manifestations include seizures, developmental delay, microcephaly, spasticity and paralysis. In addition, there are cutaneous lesions, alopecia, dystrophied nails, skeletal defects, dental anomalies (delayed eruption, conical teeth, partial anodontia), squint, optic nerve atrophy, cataracts, and retrolenticular masses. One-third patients may end up with blindness. Investigations and management are dictated by the noncutaneous abnormalities rather than skin lesions which are benign and show regression during adulthood.

THE CHILD WITH ATAXIA

The term, *ataxia* or *incoordination*, refers to the difficulty or inability to perform certain acts due to imperfect or absent cooperation between different muscles or groups of muscles.

Ataxia may be cerebellar or sensory due to involvement of posterior column. In *cerebellar ataxia*, Romberg sign (failure to maintain standing attitude while standing on tiptoes and knees bent when the eyes are closed) is usually negative whereas cerebellar signs like nystagmus, dysarthria, hypotonia and pendular jerks may be positive. The child is unable to execute rapidly-repeated movements. On the contrary his movements become slow, awkward and incomplete. This is called *adiadochokinesia*. In *sensory ataxia* due to posterior column lesion, Romberg sign is positive and there may be other evidence of sensory loss.

Table 23.15: Causes of ataxia

<i>Cerebellar</i>	
Acute:	Acute cerebellar ataxia, drug toxicity (piperazine, phenytoin), raised intracranial pressure, trauma, anoxia, seizures, hysteria, migraine, hypoglycemia, Guillain-Barre syndrome, cerebral abscess
<i>Chronic or Subacute:</i>	Space-occupying lesion (medulloblastoma, astrocytoma, tuberculoma, occult neuroblastoma), cerebral palsy, arrested hydrocephalus, congenital malformations (Arnold-Chiari or Dandy-Walker anomalies), degenerative diseases (Friedreich ataxia, ataxia telangiectasia, multiple sclerosis), metabolic disorders (abetalipoproteinemia, Hartnup disease, storage diseases), certain hereditary disorders (Refsum syndrome)
<i>Sensory</i>	Juvenile tabes dorsalis, pernicious anemia complicated by subacute combined degeneration, polyneuropathies

Table 23.15 presents the list of causes of ataxia. *Acute cerebellar ataxia*, usually occurring at 1 to 5 years of age, follows a viral infection such as chickenpox, poliovirus type I, influenza A and B, ECHO virus and coxsackie type B, or results from an autoimmune response to a variety of agents.

The onset of ataxia is always acute. In 50% of the cases, however, a nonspecific infection precedes it by about 3 weeks or less. The most dominant feature of the clinical picture is the severe truncal ataxia resulting in rapid deterioration of gait.

CSF is usually normal though a slight pleocytosis may occur in 25% of the cases. Late in the course of the disease, CSF proteins may be high.

Diagnosis is by exclusion of other causes of cerebellar ataxia. It is a self-limiting disorder, ataxia clearing fully in about 2 months in a large majority of the full-blown cases and in just a week or so in mild cases. No specific treatment is needed.

SPASMUS NUTANS

This disorder of unknown etiology is characterized by rhythmic jerking movements of head in the form of intermitted head nodding, usually in the lateral or horizontal direction, together with intermitted rapid pendular nystagmus. The movements disappear when the child concentrates or sleeps.

The manifestations are noticed from the age of 4 to 12 months, always disappearing spontaneously by the age of 3 or 4 years.

Inadequate lighting and absence of visual stimuli have been incriminated as the etiologic factors but without sufficient evidence.

THE CHILD WITH COMA

By definition, *coma*, is a state of unconsciousness from which one cannot be aroused. There is absence of all the reflexes. Accompanying coma may be respiratory failure with cyanosis and/or circulatory failure with shock.

Remember that coma is a medical emergency and a comatosed child needs prompt action.

4 Emergency Measures

While you are recording the history and physical examination or ordering investigations, make sure that emergency measures have been instituted.

- A. Ensure a clear airway.
- B. Consider oxygen administration or tracheostomy.
- C. Maintain clear airway by suction and mouth gag or oral airway.
- D. Start IV drip to administer fluids and to restore acid-base and electrolyte balance.
- E. Consider giving, blood transfusion in case of existing or imminent shock.
- F. Control convulsions, if present.
- G. Control high fever, if present.
- H. Put Ryle tube in order to empty stomach contents and/or to examine these, and to prevent occurrence of abdominal distention.
- I. Take steps to lower the raised intracranial pressure.
- J. Consider giving an antidote for narcotic overdose.

Clues to Diagnosis

History Interrogate about diabetes, head injury, CNS disease, renal disease, hepatic disease, poisoning, drug overdose and epilepsy.

Physical examination Valuable clues are usually obtained from such an examination.

A. Pattern of Respiration

- Cheyne-Stokes: Involvement at thalamic level (deep cerebral or diencephalic lesion Box 23.1)

Box 23.1: Levels of unconsciousness

Stage 0	Asleep, arousable
Stage 1	Comatose, reflexes intact, withdrawal from painful stimuli
Stage 2	Comatose, respiration normal, some reflexes absent, docs not withdraw from painful stimuli
Stage 3	Comatose, respiration normal, most reflexes absent
Stage 4	Comatose, all reflexes absent, respiratory failure and/or circulatory failure (shock).

- Irregular hyperventilation: Damage to brainstem (mid-brain or pons)
- Slow and deep: Raised intracranial pressure, CNS infection or after a convulsive episode
- Ataxic: damage to medulla; respiratory arrest usually follows
- Slow, shallow and periodic: Narcotics
- Acetone in breath: Diabetic acidosis
- Foul breath: Uremia
- Blowing out of one cheek: Ipsilateral facial paralysis
- Deep, rapid, gasping: Acidosis.

B. Pattern of Pupil Responses

- Widely dilated, fixed: Third nerve paralysis resulting from tentorial herniation
- Widely dilated but reactive: Postictal state or deep plane of anesthesia
- Pinpoint drug intoxication (opiates, barbiturates) or brainstem involvement
- Unilateral dilated, fixed: An expanding lesion on the same side (it may well be a false localizing sign)
- Midposition fixed: Involvement of midbrain level
- Roving nonconjugate deviation: Light plane of anesthesia
- Conjugate deviation: Cerebral lesion of same side or an irritative process on the opposite side
- Nystagmoid movement: Posterior fossa lesion on same side.

Doll's eye phenomenon: Turn the head briskly from side to side while patient's eyes are open. You would notice that the eyes move conjugately to the opposite side. The reflex (also called *oculocephalic response*) is depressed if the lesion is at the level of midbrain. It is entirely absent if the lesion is below this level. The reflex needs 3rd, 4th and vestibular nerves intact (Table 23.16).

C. Head and Body

Quickly examine for injury marks or evidence of ingestion of poisonous agents.

D. Fever

Hypothermia indicates possibility of barbiturate or alcohol intoxication or shock.

High fever suggests acute infection. Do not forget that it may be seen in toxic encephalopathies, heat stroke, intracranial hemorrhage or postictal state.

Table 23.16: Modified glasgow coma scoring system

Eyes Opening			
<i>Score Over 1 year</i>		<i>Under 1 year</i>	
4	Spontaneous	Spontaneous	
3	To verbal command	To shout	
2	To pain	To pain	
1	No response	No response	
Best Motor Response			
<i>Score Over 1 year</i>		<i>Under 1 year</i>	
6	Obeys	Spontaneous	
5	Localizes pain	Localizes pain	
4	Flexion withdrawal	Flexion withdrawal	
3	Flexion abnormal (decorticate rigidity)	Flexion abnormal (decerebrate rigidity)	
2	Extension	Extension	
1	No response	No response	
Best Verbal Response			
<i>Score Over 5 years</i>	<i>2 to 5 years</i>	<i>0 to 23 months</i>	
5	Oriented and converses	Appropriate words and phrases	Smiles, coos appropriately
4	Disoriented and converses	Inappropriate words	Cries, consolable
3	Inappropriate words	Persistent cries or screams	Persistent inappropriate crying or screaming
2	Incomprehensible sounds	Grunts	Grunts, agitated or restless
1	No response	No response	No response

Note: A score of 9 or more rules out coma whereas a score of less than 7 confirms coma. Most subjects scoring 8 are too having coma

E. Neck Rigidity

It suggests meningitis. Subarachnoid hemorrhage or herniation of cerebral tonsils may also manifest with nuchal rigidity. However, remember that it may be absent in a comatose child despite his having been suffering from one of these disorders.

F. Limbs

Failure to move one side or asymmetrical movements suggest paralysis.

In hemiplegia, the paretic leg lies in external rotation and moves less than the normal leg, spontaneously as also in response to painful stimuli. When lifted and allowed to fall back, it drops limply.

Decerebrate posturing, characterized by arms which are flexed over the chest, hands which are fisted, and legs which are extended, suggests diffuse cerebral cortex lesion.

Decorticate posturing, characterized by rigid extension and pronation of legs, as such or in response to pain, suggests midbrain lesion. Unilateral decerebrate posturing, often accompanied by contralateral third nerve palsy is usually a sign of tentorial herniation.

G. Reflexes

Absence of corneal reflex or tonic neck reflex suggests severe brain damage.

A consistently positive Babinski sign may be of value.

H. Fundoscopy

Early signs of raised intracranial pressure are absence of venous pulsations and distention of retinal veins. Preretinal hemorrhages suggest subarachnoid or subdural hemorrhage.

Since papilloedema takes 24 to 48 hours to manifest, its absence does not mean raised intracranial pressure is ruled out.

I. Focal Signs in Relation to RIP

A. Focal Signs with RIP

- Trauma: Subdural, epidural or intracerebral hemorrhage; subdural contusion
- Intracranial tumor
- CNS infection: Brain abscess, subdural empyema, encephalitis
- Vascular lesions: Arteriovenous malformations.

B. Focal Signs with Normal ICP

- Vascular lesion: Cerebral artery occlusion
- CNS infection: Encephalitis
- Trauma: Cerebral confusion
- Epilepsy: Postictal state with Todd paralysis.

C. *RIP with Absent Focal Signs*

- Metabolic encephalopathy: Lead poisoning, water intoxication, Reye syndrome, severe anoxia
- CNS infection: Meningitis, encephalitis
- Trauma: Subdural hemorrhage in infants, sub-arachnoid hemorrhage
- Intracranial tumors
- Hydrocephalus

D. *Normal ICP and No Focal Signs*

- Metabolic encephalopathies: Most of them
- Drug intoxication
- CNS infection: Meningitis, encephalitis
- Trauma: Concussion
- Epilepsy: Postictal state.

Lumbar Puncture

High pressure—Intracranial infections, space-occupying lesions

High proteins—Meningitis

High cell count with predominance of polymorphs—Pyogenic meningitis

High cell count with predominance of lymphocytes—Tuberculous meningitis

Nearly normal picture—Encephalitis.

Management

Once emergency treatment has been instituted and the diagnosis arrived, the specific treatment will be of the underlying cause of coma.

Keep vigilant during treatment. The continuous reassessment may indicate need for a change in the treatment at a later stage or minor alterations from time to time. For instance, it is a practice to substitute nasogastric feeding for IV drip, if coma is prolonged. Bladder, may, at some point, need catheterization.

There is hardly a place for prophylactic antibiotics in the management of coma unless you are so unsure of the sterile techniques employed in the management.

Table 23.17: AEIOU: A mnemonic for causes of coma

A	<i>Acidosis.</i> Accidents Alcohol
E	<i>Epilepsy</i> Encephalitis Encephalopathy Electrolyte imbalance
I	<i>Injury</i> Intoxication Insulin shock
O	<i>Oxygen deprivation</i> Overdose of opiates, etc.
U	<i>Uremia</i>

Investigations (Table 23.17)**Urine Examinations**

Acetonuria and glycosuria—Diabetes, sometimes lead encephalopathy, salicylism or cerebrovascular accident.

Albuminuria—Uremic coma, lead and other heavy metal poisoning or high fever.

Bilirubinuria—Hepatic failure (hepatic coma from viral hepatitis or Reye syndrome).

A positive ferric chloride test—Phenothiazine poisoning, salicylism.

Blood Picture

High blood glucose—Diabetes

Low blood sugar—Hypoglycemia, Reye syndrome

Low CO₂ and chlorides—Acidosis

High BUN—Uremia

High liver enzymes and ammonia with low bilirubin—Reye syndrome.

DEGENERATIVE BRAIN DISORDERS

These disorders are characterized by progressive loss of intellectual, motor and sensory functions with waxing and waning of manifestations over a prolonged period and no effective therapy.

Table 23.18 gives the classification based on area of principle involvement.

The dominant early manifestations in gray matter involvement include dementia and convulsions. Eventually, however, the whole nervous system suffers.

The dominant early manifestations in white matter involvement include deterioration in motor function in the form of spasticity, hypotonia or ataxia. With progression of the disease, the whole nervous system suffers.

The end-stage clinical picture in all degenerative disorders is more or less similar, the patient losing all intellectual and voluntary motor functions and becoming helpless.

Subacute sclerosing panencephalitis (SSPE) manifests, on an average, 7 years after the primary infection

Table 21.18: Classification of degenerative brain disorders according to area of brain principally involved

I. <i>Gray matter involvement</i>	
A. <i>With storage</i>	
<ul style="list-style-type: none"> • Infantile Gaucher disease • Niemann-Pick disease • Farber disease • Tay-Sach disease • Cerebromacular degeneration • Generalized gangliosidosis 	
B. <i>Without storage</i>	
<ul style="list-style-type: none"> • Kinky hair (Menke's) disease • Subacute sclerosing panencephalitis (SSPE) • Leigh disease • Alper disease 	
II. <i>White matter involvement</i>	
A. <i>Leukodystrophies</i>	
<ul style="list-style-type: none"> • Metachromatic leukodystrophy • Cerebroside lipidosis • Sudanophilic leukodystrophy • Canavan disease 	
B. <i>Demyelinating</i>	
<ul style="list-style-type: none"> • Schilder disease • Neuromyelitis optica • Multiple sclerosis 	
III. <i>Systemic degeneration</i>	
A. <i>Cerebellar/Spinocerebellar</i>	
<ul style="list-style-type: none"> • Friedreich ataxia • Refsum disease • Ataxia-telangiectasia • Bassen-Kornzweig syndrome 	
B. <i>Basal ganglia</i>	
<ul style="list-style-type: none"> • Hepatolenticular degeneration • Huntington chorea • Dystonia musculorum deformans • Hallervorden-Spatz disease 	

with measles. The peak incidence occurs at 7 to 15 years though it has been reported in subjects aged 6 months to 30 years. Manifestations include personality changes followed by generalized myoclonic jerks and, at times, grand mal seizures. With progression of the disease, the patient becomes demented, rigid and bedridden. The disease invariably proves fatal within 2 years. CSF is normal except for high gamma globulin levels and measles antibody titer of more than 1 in 128 by complement fixation method. EEG shows regularly repeated bursts of generalized high voltage slow wave complexes. CT scan or MRI reveals variable cortical atrophy, ventricular enlargement and focal or multifocal low density lesions in white matter in

established disease. Brain biopsy (no longer required for diagnosis) shows perivascular lymphocytic infiltration, inclusion bodies in neurons and glial cells, loss of neuronal cells, gliosis and, at times, growth of measles virus from cerebral tissue. Management is by and large symptomatic and supportive. Inosiplex, 100 mg/kg/day in divided doses, causes some clinical improvement and prolonged survival. The disease is also termed Dawson encephalitis after the name of Dawson who first described it.

Rett syndrome, occurring exclusively in females, is characterized by regression of motor milestones and language after 1 year of age, ataxic gait or fine tremors of hands, sighing respiration with intermittent apneic spells, repetitive hand-wringing movements and autistic behavior. Associated features include generalized tonic-clonic seizures, feeding problems, and poor weight gain. Endorphin level in CSF is elevated. Treatment with anticonvulsants controls seizures and with naltrexone, an opiate-receptor agent, improves apnea and behavior problems in a proportion of cases.

Kinky hair (Menkes) disease, a sex-linked recessive disorder of copper metabolism, is characterized by poor weight gain, proneness to infection and, latter, hair becoming sparse and brittle, and myoclonic seizures. X-ray shows scurvy-like picture in long bones. Serum copper and ceruloplasmin levels are reduced. Despite parenteral copper therapy, gross cerebral and arterial changes prove fatal in infancy *per se*.

Metachromatic leukodystrophy, the most common of the leukodystrophies, is an autosomal disorder due to deficiency of arylsulfatase A (ASA) in brain and other tissues. Manifestations, appearing at about 1 year of age, include gait disturbances, spasticity, hyperreflexia, extensor plantars, brisk tendon reflexes with the exception of ankle jerk which may be sluggish or absent, flaccid weakness and wasting of muscles and, eventually, dementia and immobility. Most patients are dead by the age of 10 years. Prenatal diagnosis by amniocentesis is possible.

Demyelinating diseases are characterized by breakdown of myelin in CNS only and are supposed to be secondary to an autoimmune or viral etiology. Three types are known:

1. *Schilder disease* manifests with cortical blindness, optic neuritis, cortical deafness, spastic hemiplegia

or paraparesis, aphasia, convulsions, and, at a later stage, dementia and coma. Raised intracranial pressure occurs only occasionally. Partial remission may occur rarely.

2. *Multiple sclerosis* manifests by cerebellar ataxia, spasticity, retrobulbar optic neuritis and atrophy, diplopia, and blindness. Course is relapsing and IQ is preserved till late. Therapeutic measures include short courses of ACTH, physiotherapy, treatment of UTI and bladder care. Symptom-free remission for many years are known.
3. *Neuromyelitis optica (Devic disease)* manifests with eye pain and blindness followed in some days by spinal cord involvement in the form of first lower motor neuron and then upper motor neuron paralysis of the legs. Upper level of sensory involvement is in thoracic area. Fundoscopy may show swelling and hyperemia of disc, distention of retinal veins and peripapillary hemorrhages. A 5 to 7 days course of dexamethasone (high doses) is indicated. Vision usually returns but some paraparesis persists. Friedreich ataxia, the most common of the spinocerebellar degenerations, usually has autosomal recessive inheritance. Manifestations include ataxia with skeletal defects such as pes cavus (high arched foot), hammer toes and scoliosis, dysarthria, intention tremors, nystagmus, extensor plantars, loss of tendon reflexes, muscle wasting, and cardiomegaly. No effective treatment is available. Death usually follows CCF.

Hepatolenticular degeneration (Wilson disease), an autosomal recessive disorder of copper metabolism, is characterized by triad of cirrhosis, neurologic manifestations and Kayser-Fleischer rings. Hepatomegaly, due to excessive accumulation of copper, is the earliest manifestation. Splenomegaly, jaundice and anorexia follow it. Edema, ascites or gastrointestinal bleeding occur sooner or later. Neurologic manifestations include proximal tremors of outstretched arms and wrists (wing-beating tremors), dysarthria and dystonia at an advanced stage. Serum copper and ceruloplasmin levels are reduced whereas liver tissue copper exceeds 400 mcg/g dry weight. Therapy consists in giving a chelating agent, penicillamine, and low copper diet. This has greatly improved prognosis of this fatal disease.

PARAPLEGIA

The term, *paraplegia*, refers to paralysis of both lower limbs usually following diseases of spinal cord and,

infrequently, intracranial lesions, peripheral nerve lesions or muscle diseases. When paralysis is incomplete, the weakness is partial. The term, *paraparesis*, is more appropriate in such a situation.

Paraplegia may be acute or chronic, spastic or flaccid, and complete or incomplete.

In *paraplegia in flexion* there is complete involvement of the pyramidal tracts of the spinal cord. The tone in the lower limbs is more reduced in the flexors, thereby making them more flexed at knee and hip. A stimulation cause painful flexor spasm.

In *paraplegia in extension* the spinal cord lesion is incomplete. There is increase in tone of the extensors of the lower limbs.

The term, *quadriplegia* or *tetraplegia*, implies involvement of all the four limbs.

The term, *monoplegia*, refers to involvement of only one limb.

Etiopathogenesis

Table 23.19 provides etiologic classification depending on whether paraplegia is spastic or flaccid. Notable causes of cortical paraplegia include cerebral palsy, cortical venous thrombosis and spinocerebellar hereditary spastic paraplegia. More important among the spinal causes are transverse myelitis, epidural abscess, caries spine, GBS, poliomyelitis, trauma and herpes zoster.

Table 23.19: Etiology of paraplegia

Spastic (<i>Upper motor neuron type</i>)
Spinal cord compression: Extradural, intradural or intramedullary primary tumors, secondaries, abscesses
Vascular: AV malformations, telangiectasia, angiomas
Inflammatory: Transverse myelitis from neuromyelitis optica, tuberculosis
Degenerative: Familial spastic paraplegia
Demyelinating: Postvaccinal (antirabic vaccine)
Congenital/hereditary: Cerebral palsy, Friedreich ataxia
Toxic: Lathyrism
Flaccid (<i>Lower motor neuron type</i>)
Spinal shock: Initial manifestation following spinal trauma, inflammation, vascular or neoplastic insult
Inflammatory/postinflammatory: Poliomyelitis, Guillain-Barré syndrome, polyneuritis
Muscle weakness: Peroneal muscular atrophy, myasthenia gravis, muscular dystrophies
Miscellaneous: Riley-Day syndrome, asymptomatic reflexia (Adie pupil), hysteria

Clinical Features

In addition to the manifestations of causative lesion the child shows following features depending on involvement of upper or lower motor neurons:

Upper motor neuron lesion: 1. Presence of exaggerated deep reflexes with clonus below the location of the spinal cord lesions, 2. Loss of power of a group of muscles, 3. Upgoing big toe (extensor plantar response) 4. Upper motor type of bladder.

Lower motor neuron lesion: 1. Presence of muscle wasting/fasciculations, 2. Root pains, 3. Circumferential segmental hyperesthesia and exaggerated autonomic, 4. Absence of certain superficial or deep reflex, 5. Autonomous bladder.

Though initially the paraplegia may well be flaccid, in due course it becomes spastic from stimulation of pain fibers and the resultant painful flexor spasms.

Diagnosis

A detailed history and physical examination assist in arriving at the precise diagnosis of paraplegia and determine the level of lesion. You must actively look for a spinal swelling/tenderness, dimple, tuft of hair or lipoma.

Table 23.20 gives the useful information for localizing the causative lesion in paraplegia.

Management

It depends on the etiologic diagnosis.

Acute myelitis needs steroids in high doses (either prednisolone as high as 5 mg/kg/day (O) or methylprednisolone pulse (IV) for 3 days. Naloxone, 5 mg/kg/day, is of value in reducing the ischemic damage.

ATT with steroids plus local treatment is needed in case of caries spine.

Traumatic paraplegia may well be an indication for a surgical intervention.

Paraplegia secondary to spinal growth too is an indication for a surgical intervention.

A good *nursing care* with attention to skin, bladder and bowel is mandatory. A good nursing care involves frequent turning of the patient in the bed provided with foam mattress so that decubitus ulcers are prevented.

Physiotherapy involves emptying the urinary bladder by compression or catheterization so that it does not become distended, atonic, and even spastic with frequent but only incomplete reflex emptying. Inappropriate bladder drainage makes it quite susceptible to UTI, requiring specific therapy.

First passive and later active physiotherapy helps to prevent contractures and deformities.

Table 23.20: Manifestations and signs helpful in localizing lesion in pediatric paraplegia

Observed symptoms and signs	Muscles involved	Level of lesion
Spastic paralysis of trunk and lower limb muscles; reflexes in lower limbs brisk.	Flexors of wrists and fingers, muscles of the hand	C8, T1
Spastic paralysis of abdomen and lower limb muscles.	Intercostals, rectus abdominalis (both upper and lower), oblique abdominalis	T6
Spastic paraplegia; upper abdominals absent	Lower half of rectus abdominalis	T9 T10
Spastic paraplegia; lower abdominals absent	Lower fibers of oblique abdominalis and transversalis iliopsoas	T12 L1
Spastic paraplegia; knee jerk lost, ankle jerk present	Quadriceps, abductors of hip	L3 L4
All movements in lower limbs weak, except flexion of hip, adduction of thigh, extension of knee and dorsiflexion of foot; knee jerk, ankle jerk, plantars absent	Gluteals, calves, anterior tibials, peroneals, small muscles of foot	S1 S2
Anesthesia below folds of groin (including genitalia), bladder and rectal control lost; deep reflexes absent	Paralysis of lower limbs	Whole cauda equina
Sensory loss over front, lateral and posterior aspect of thighs, knee jerk and ankle jerk absent	Paralysis of gluteal, hamstrings and all muscles below knee	Upper sacral L5
Saddle-shaped area of anesthesia, urinary incontinence, fecal incontinence; no reflex in lower limb affected	No lower limb paralysis	Below S2
Anesthesia of anus and rectum	Paralysis of levator ani	S4 S5

FURTHER READING

Articles/Chapters

1. Aneja S. Acute bacterial meningitis. In: Gupte S (Ed): *Recent Advances in Pediatrics-6*. New Delhi: Jaypee 1996;340.
2. Dua T, Aneja S. Neurocysticercosis: Management issues. *Indian Pediatr* 2006;43:227.
3. Fellick JM, Thompson APJ, Sills J, Hart CA. Neurological soft signs in mainstream pupils. *Arch Dis Child (Indian edn)* 2002;1:16.
4. Puri V. Intractable epilepsy. In Gupte S (Ed): *Recent Advances in Pediatrics-9*. New Delhi: Jaypee 1999:194.
5. Purohit AK. Selective posterior rhizotomy. In Gupte S (Ed): *Recent Advances in Pediatrics-2*. New Delhi: Jaypee 1992:35.
6. Rekha S. Tuberculous meningitis (TBM). In Gupte S (Ed): *Recent Advances in Pediatrics-9*. New Delhi: Jaypee 1999:48.
7. Sankar C, Mundkur N. Cerebral palsy: definition, classification, etiology and early diagnosis. *Indian J Pediatr* 2005;72:859-864.
8. Savitha MR, Krishnamurthy B, Ashok DA, Ramachandra NB. Self abortion of attacks in patients with hot water epilepsy. *Indian Pediatr* 2007;44:295.
9. Talukdar B. Congenital hydrocephalus. In Gupte S (Ed) *Recent Advances in Pediatrics-7*. New Delhi: Jaypee 1997:202.
10. Thomas SG, Thomas M. Role of surgery in pediatric epilepsy. *Indian Pediatr* 2007;44:263.

Books/Monographs

1. Baram TZ, Shinnar S. Febrile Seizures. San Diego: Academic Press 2002.
2. Gupte S. *Recent Advances in Pediatrics (Special Vol 18: Pediatric Neurology)*. New Delhi: Jaypee 2008

CHAPTER



24

Pediatric Gastroenterology

Suraj Gupte, RA Anderson

BASICS OF GASTROINTESTINAL TRACT (GIT)

The term, *gastrointestinal tract (GIT)*, refers to the alimentary tract extending from the mouth to the anus. It is divided into mouth, oropharynx, esophagus, stomach, small intestine (jejunum and ileum) and large intestine (colon). *On ingestion* of food by the mouth, it is moved by the oropharynx into the esophagus. The latter acts as a conduit for transfer of food to the stomach where it is stored and mixed prior to its controlled passage into the small intestine where it is digested and absorbed. Then, it moves to large intestine where salts and water are conserved prior to excretion as feces. Undoubtedly, the normal GIT function is the net result of combined action of many functional systems. If there is a breakdown of any one, intestinal function will be disturbed. For instance, diarrhea develops when there is an enhanced overload of fluids from small intestines into the colon following maldigestion or active secretion, or when the absorptive capacity of the colon is compromised by disease. A defect of intestinal mucosal immunity may lead to recurrent enteric infections. Intestinal obstruction follows loss of normal intestinal motility. An insult to the digestive or absorptive capacity of the GIT may cause digestive and abdominal complaints, failure to thrive and even weight loss.

SPECIAL INVESTIGATIVE WORK-UP FOR GASTROINTESTINAL DISORDERS

For esophageal structure and function:

- Barium meal studies for defining anatomy of upper GIT and detecting advanced mucosal lesions, e.g. varices and GER.
 - Endoscopy for varices.
 - 24-hour pH monitoring is the most sensitive test for gastroesophageal reflux (GER).
 - Esophagoscopy for esophagitis and mucosal biopsy.
- For maldigestion/malabsorption*
- Stool examination, including fat globules, reducing substances, pH, and microscopy. In case of a strong suspicion of intestinal parasitosis, it is advisable to carry stool microscopy by concentration method for at least 3 (preferably 6) consecutive days since ova and cysts frequently pass intermittently. For details, see Chapter 44.
 - 24-hour stool fat by fat balance studies and chemical examination of stools or by a semi-quantitative method termed "steatocrit". A daily stool fat of >5 g is considered indicative of steatorrhea.
 - D-xylose test consists in measuring excretion of xylose in a 5-hour sample of urine after administering the pentose in a dose of 1 g/kg BW. An excretion of < 20 % points to malabsorption. A tolerance test too is available for infants and small children in whom collection of urine sample is quite cumbersome.
 - Lactose tolerance test.
 - Breath test involving measurement of H⁺.
 - Barium meal follow-through, employing a non-flocculable medium, may reveal intestinal changes indicative of malabsorption such as intestinal dilatation, flocculation, and atypical mucosal pattern, plus anatomic defects.
 - Peroral or endoscopic gastric or jejunal biopsy. The jejunal biopsy provides vital histologic details as

well as the material for enzymes, *disaccharidases*, especially, *lactase*, assay. It may also identify such pathogens as *L. giardia* and *H. pylori*. Gastric biopsy may be employed for histopathology, culture or rapid urea test for *H. pylori*.

- Schilling test measures the vitamin B₁₂ absorption from the gut. It consists in administering a tracer dose of radioactive vitamin B₁₂, after saturating body stores with vitamin B₁₂, and its urinary excretion measured over the next 24 hours. An excretion of < 5% indicates defective absorption from the ileum.
- Sweat chloride estimation by iantophoresis, using pilocarpine, is important for assay of the exocrine pancreatic function. A level of > 60 mEq/L usually established the diagnosis of cystic fibrosis.

acidic with reducing substances. *Motility diarrhea* is associated with increased (irritable bowel syndrome) or delayed motility (intestinal pseudoobstruction).

Acute diarrhea refers to diarrhea that begins acutely and terminates within a week or so, only a small proportion of cases passing to the second week or even beyond.

Chronic diarrhea refers to diarrhea beyond 2 weeks. The term is best reserved for cases with an obvious malabsorption or an underlying organic disease without obvious malabsorption.

The term *persistent diarrhea* denotes an episode of acute diarrhea, presumably of infective origin, that lasts for 2 weeks or more.

The term, *intractable diarrhea* of infancy, should be reserved for cases who have onset of protracted diarrhea before the age of 3 months. These infants start as an infective diarrhea, become dehydrated and wasted and have high mortality. They need emergency treatment.

ACUTE DIARRHEA

Acute diarrhea, often called *acute gastroenteritis*, is, in particular, a leading cause of mortality in pediatric practice. This emergency accounts for as high as 75% of our pediatric admissions at certain times during the peak summer and rainy seasons. The incidence and mortality are especially high in infancy, more so in the presence of malnutrition and erratic feeding practices.

According to a conservative estimate, almost 500 million children suffer from acute diarrhea annually. Of them, 5 million die every year. In India alone, nearly 1.5 million children die due to acute diarrhea every year.

Etiology

Table 24.1 lists various causes of acute diarrhea in infancy and childhood.

That acute diarrhea is mostly infectious in origin in pediatric practice is borne out by the following points:

1. Magnitude of diarrhea prevalence is directly proportional to sanitary and personal hygiene standards of the community.
2. Acute diarrhea in the community behaves on the same lines as other infectious diseases.

4 DIARRHEAL DISEASES: AN OVERVIEW

Diarrheal diseases rank among the “top three” causes of death in pediatric population of the developing world. Globally, approximately 4-5 million deaths occur as a result of diarrheal diseases every year. Eight out of these 10 deaths are in the first 2 years of life, the most susceptible period for malnutrition. As indicated in Chapter 2, diarrheas account for about 20% of the hospitalized pediatric cases in India.

On an average, a child suffers from around 12 episodes of diarrhea, 4 such episodes occurring during the very infancy (first year). Existence of malnutrition makes the child very much vulnerable to diarrheal disease. It is estimated that incidence of diarrhea in malnourished children is 5 to 7 times higher than in healthy children. Likewise, its severity too is 3 to 4 times greater.

By definition, *diarrhea* means passage of 3 or more loose or watery motions per 24 hours, resulting in excessive loss of fluid and electrolytes in stools. Secretory, osmotic or motility abnormalities, singularly or in combination, form the basis of all diarrheal episodes. *Secretory diarrhea* has a tendency to be watery, voluminous and persistent even when no feeding is given orally. It is usually caused by an external or internal secretagogue (cholera toxin, lactase deficiency). *Osmotic diarrhea* follows ingestion of a poorly absorbed solute because of an inherent character of the solute (magnesium phosphate, alcohol, sorbitol) or a small bowel defect (lactose in lactase deficiency in brushborder). It tends to be watery and

3. Infants and children are more frequently and more severely affected than older people, indicating poor immunity in the former.

Viral diarrhea: Recent evidence has indicated that viruses, such as rotavirus and Norwalk and Norwalk-like agents, are responsible for majority of the acute diarrhea in infants and young children.

Table 24.1: Etiology of pediatric acute diarrhea

A. Enteric Infections	
Bacteria:	<i>E. coli</i> , <i>Shigella</i> , <i>Salmonella</i> , <i>Staphylococcus</i> , <i>Cholera vibrio</i> , <i>Yersinia enterocolitica</i> , <i>Campylobacter jejuni</i> , <i>Clostridium difficile</i> , <i>Aeromonas hydrophilia</i> , <i>Vibrio parahemolyticus</i> , <i>Plesiomonas shigelloides</i> .
Viruses:	Rotavirus, Norwalk and allied viruses, enterovirus, Influenza virus, measles virus.
Parasites:	<i>Ent. histolytica</i> , <i>Giardia lamblia</i> , <i>Cryptosporidium</i> , <i>H. nana</i> , malaria
Fungi:	<i>Candida albicans</i> .
Parental:	URI, otitis media, tonsillitis, pneumonia, urinary tract infection.
B. Dietetic/Nutritional: Overfeeding, starvation, food allergy, food poisoning.	
C. Drugs: Antibiotics	
D. Nonspecific.	

Rotavirus, also termed *GEV* (gastroenteritis virus) and *Due virus*, is the most frequently encountered virus in diarrheal stools of children. Four established serotypes of rotavirus account for 20 to 40% of acute diarrhea. Age 9 to 12 months appears to show the peak incidence. Excepting newborns, it has been observed to have a predilection for winter and dry months in the Indian subcontinent. Transmission is by fecooral route.

The virus causes reversible patchy villous atrophy and loss in the absorptive capacity of the intestinal mucosa in a cephalocaudal direction. A marginal reduction in disaccharidases with some reduction in carbohydrate absorption is usually present. Such brushborder enzymes as alkaline phosphatase, sucrase and trehalase are also reduced. The small intestinal morphology and function revert to normal within 2-3 weeks.

The incubation period is usually less than 48 hours (range 1 to 7 days). The average duration of illness is 5 to 7 days.

An important clinical feature of rotavirus diarrhea is the vomiting that usually precedes the onset of

watery motions. About 30 to 50% cases show slight fever, 25% mucus in stools and just an occasional case blood in stools and is responsible for 10 to 20% of acute diarrheal cases.

Recently, a new group of viruses, *Norwalk and Norwalk-like agents*, has been discovered to be associated with outbreaks of generally mild gastroenteritis occurring in school, community and family settings. It was first detected in Norwalk, Ohio, in 1972.

Notwithstanding minor histologic insult to small intestinal mucosa, brushborder enzymes are reduced.

The incubation period is around 48 hours. The attack is usually mild and self-limited, lasting 12 to 24 hours in a majority of the cases.

Vomiting, abdominal pain, anorexia, headache, myalgia and malaise are important features of diarrhea secondary to this group of viruses.

Other viruses incriminated in the etiology of diarrhea include Hawaii virus, adenovirus, astroid virus, calcivirus, coronavirus, enterovirus and minirovirus.

Bacterial diarrhea: This constitutes the next major group. The most dominant pathogen in this category is *Escherichia coli*. Diarrheagenic *E. coli* have 5 classes, namely, enteropathogenic (EPEC), enterotoxigenic (ETEC), enterohemorrhagic (EHEC), enteroadherent (EAEC) and enteroinvasive (EIEC). ETEC are notorious for causing dehydrating diarrhea in developing countries. *EIEC* causes shigellosis-like illness. EPEC is responsible for prolonged diarrhea (nonbloody) with mucus and at times pyrexia. EHEC is characterized by abdominal pain and diarrhea which soon becomes bloody (hemorrhagic colitis) as in case of shigellosis. This is called *EIEC* illness. Risk of developing hemolytic-uremic syndrome in EHEC diarrhea with pyrexia is enhanced. EAEC usually causes dehydrating diarrhea which often becomes prolonged as in case of EPEC.

Cholera vibrio 01 and 0139, contrary to the widely-held belief, causes severe watery diarrhea and vomiting only in a minority of the children. In most cases, the infection is mild with minor or no symptoms.

Shigella, *Campylobacter jejuni* and *nontyphoidal Salmonella* account for about 10%, 12% and 3% of acute diarrhea cases, respectively. These bacteria, along with *enteroinvasive E. coli* may cause damage to the mucosa of distal ileum and colon through their toxins, leading to formation of ulcers as also mucosal secretion of water and electrolytes, and dysentery.

Parasitic diarrhea: *L. giardia* is an important cause of recurrent diarrhea. *E. histolytica* is encountered relatively less frequently in infants and children, *H. nana* is common in some pockets only. These three pathogens may infrequently cause even dysentery-like manifestations.

Cryptosporidium, a coccidian protozoan parasite, typically causes watery diarrhea, varying from mild to severe, together with crampy epigastric pain, vomiting, anorexia, malaise and loss of weight. In immunodeficiency states (HIV infection, congenital hypogammaglobulinemia, immunosuppressant therapy in hematogenous malignancies), cryptosporidiosis may cause persistent diarrhea which frequently ends up fatally.

4 Pathogenesis

The delicate balance in the ecology of the gastrointestinal tract needs to be broken down by any of the two situations in order that diarrhea occurs:

1. The conditions in which the defence weakens, say malnutrition (both primary and secondary), immunologic disorders, etc. so that even commensals, organisms with weak virulence, or opportunist organisms overpower and cause diarrhea..
2. The known pathogens overcome the natural defence.

The pathogenic organisms produce diarrhea by one or more of the following mechanisms:

1. Adhesion to the intestinal mucosal wall, e.g. *enteropathogenic E. coli* (EPEC) which are further categorized as class I EPEC (showing localized adherence) and class II EPEC (showing diffuse adherence).
2. Elaboration of an exotoxin, (secretory diarrhea) e.g. rotavirus, *enterotoxigenic E. coli* (ETEC), *Vibrio cholera*, *Aeromonas hydrophilia*, *Plesiomonas shigelloides*, causes excessive secretions. Fasting has no effect
3. Mucosal invasion (exudative diarrhea), e.g. *enteroinvasive E. coli* (EIEC), *Shigella*, *Salmonella* (nontyphi), *Cl. Difficile*, *Campylobacter jejuni*, *Yersinia enterocolitica*, *enteropathogenic E. coli* (EPEC), rotavirus, damage and exudative blood. No effect of fasting.

The term, *Osmotic diarrhea*, denotes diarrhea from concentrated substances (antacids, lactose, lactulose) which are not absorbed from the gut. They pull water

from intestinal wall into stools. Such diarrhea subsides on fasting.

In order to appreciate the modus operandi of diarrheal dehydration and dyselectrolytemia, it must be noted that diarrheal losses are drawn from extracellular fluid (ECF) compartment constituted by circulating blood, interstitial fluid and secretions. This compartment accounts for the 60% of the body weight of the child.

Loss of water from the child's body causes shrinkage in the volume of the ECF compartment. In around one-half cases with excessive sodium loss in stools, hyponatremia develops as a result of fall in serum and ECF sodium levels. Since sodium is the major determinant of osmolality, there results fall in osmolality of ECF. Then follows movement of water from ECF to ICF compartment. Further shrinkage of the already shrunk ECF compartment volume becomes inevitable. This is manifested in the form of loss or impairment of skin elasticity.

In a small proportion of cases in whom diarrheal dehydration has been treated with fluids containing far too much of sodium, osmotic pressure of ECF becomes high, prompting water in ICF compartment to move to ECF compartment. This is likely to camouflage the existence of severe dehydration which may erroneously be interpreted as mild dehydration.

Depletion of ECF compartment leads to reduction in blood volume, causing peripheral circulatory failure and oliguria or anuria.

Loss of potassium in stools leads to hypokalemia, causing abdominal distention, hypotonia and ECG changes in the form of ST depression and flat T wave.

Loss of bicarbonate in stools leads to acidemia, causing acidotic respiration (Kussmaul breathing) which is characteristically deep and rapid.

Clinical Features

The clinical picture varies in mild, moderate and severe cases (Fig. 24.1; Tables 24.2 and 24.3).

Mild In mild cases, onset is usually insidious with 2 to 5 motions which may be loose, green, offensive and contain mucus and milk curds. The volume may be small or large. The attack usually subside in a day or two without any remarkable constitutional manifestations or dehydrations.

Moderate The number of motions is 10 or more and constitutional symptoms like fever, irritability,

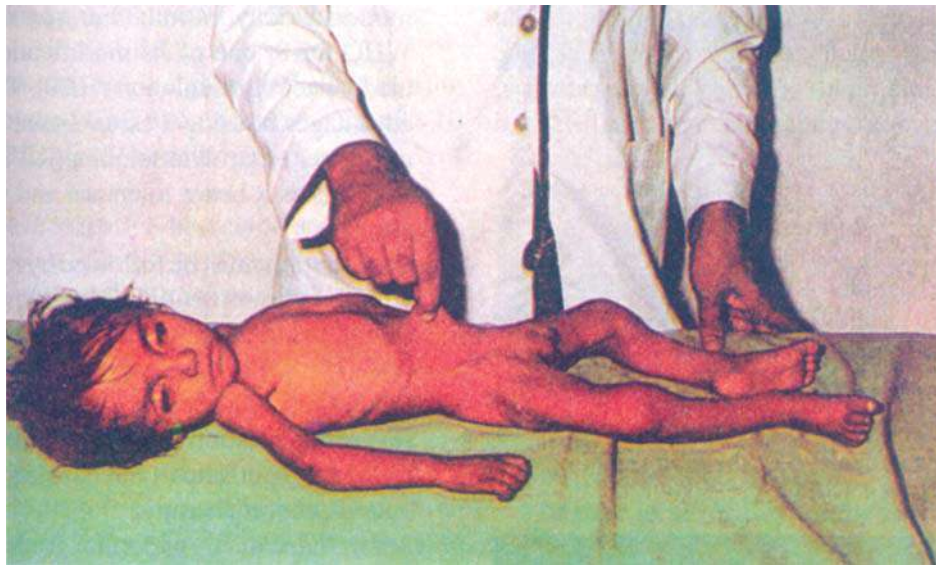

Fig. 24.1: Severe diarrheal dehydration. Note the characteristic features, including moribund state with shock, acidosis and anuria. ORS, hailed as the most important medical advance of the 20th century, has the potential of saving 10,000 children each day—the child population that could otherwise die from diarrheal dehydration

Table 24.2: Clinical features of viral vs bacterial diarrhea

Features	Viral diarrhea	Bacterial diarrhea	
		Noninvasive	Invasive
Character of motions	Watery	Watery or semisolid with mucus but no blood	Semisolid, small amount, very frequent, with mucus and blood
Vomiting	Severe	Only slight	Moderate
Pyrexia	Slight	Nil	Moderate to high
Upper respiratory infection	Usually present	Nil	Nil
Seizures	Nil	Nil	Occasionally
Toxemia	Nil	Nil	Slight
Stool microscopy	Moderate pus cells	NAD	Moderate pus and red cells

anorexia and vomiting are usually present. Mild dehydration (3 to 5%) is associated.

Severe Here the child passes “too many” loose motions and has severe vomiting to the extent that nothing is retained and the oral intake becomes virtually impracticable. Such cases are most often characterized by sudden rather than gradual onset. They may have marked constitutional symptoms. Moderate (5 to 10%) to severe (>10%) dehydration further aggravates the clinical picture.

Table 24.3 summarizes the clinical picture seen in different grades of dehydration.

Table 24.3: Clinical picture of different grades of dehydration

Grades	Clinical pictures
Mild (3 to 5% weight loss)	Irritability or drowsiness; pallor; somewhat sunken eyes.
Moderate (6 to 10% weight loss)	Sick-looking child; pallor; depressed fontanel; sunken eyes; dry mucous membrane; dry and inelastic skin.
Severe (>10% weight loss)	Signs of superimposed shock, like coma, limpness, pallor, cold and clammy skin, thin rapid or almost impalpable peripheral pulses; metabolic acidosis; oliguria or anuria.

Manifestations secondary to CNS disturbances are prominent in all types of severe dehydration (Table 24.4). Hypertonic dehydration has more of these. Early irritability, alternating with apathy, may progress to restlessness, cloudiness of consciousness, delirium or stupor, lethargy and coma. Convulsions may occur at any stage. The high viscosity of blood may cause as serious a complication as cerebral thrombosis.

Table 24.4: Clinical picture in isotonic, hypotonic and hypertonic dehydration

Criteria	Isotonic	Hypertonic	Hypotonic
Skin			
Color	Gray	Gray	Gray
Temperature	Cold	Cold or hot	Cold
Turgor	Poor	Fair	Very poor
Feel	Dry	Thickened	Clammy (moist)
Mucous membrane	Dry	Parched	Slightly moist
Eyes	Sunken and soft	Sunken	Sunken and soft
Anterior fontanel	Depressed	Depressed	Depressed
Sensorium	Drowsy	Very irritable	Comatose
Pulse	Rapid	Moderately rapid	Rapid
Blood pressure	Low	Moderately low	Very low

In addition to cerebral thrombosis, conditions that may cause seizures in acute diarrhea or AGE include marked hyponatremia, rapid correction of hypernatremia, hypocalcemia, hypomagnesemia, encephalitis and shigellosis.

Clinical Assessment of Diarrheal Dehydration

Since laboratory investigations are most often not available, it is advisable to make the best use of one’s clinical knowledge in evaluating the grades and type of dehydration (Tables 24.1 to 24.6).

Table 24.5: Clinical picture in certain special situations

Conditions	Physical signs
Acidosis	Breathing increased in depth and rate
Alkalosis	Breathing decreased in depth and rate; latent or manifest tetany.
Hypokalemia	Abdominal distention, paralytic ileus hypotonia, hyporeflexia; mental apathy; ECG changes.
Hyperkalemia	Fibrillation or paralysis of skeletal muscles; ECG changes
Hypocalcemia	Tetany; paralytic ileus
Hypercalcemia	Hypotonia; fecal masses
Hypomagnesemia	Tetany; muscular twitching
Hypermagnesemia	CNS depression; hyporeflexia

Treatment

A. Conventional Rehydration Therapy

Replacement of the fluids as soon as possible, is the sheet-anchor of management of acute diarrhea.

1. *Oral rehydration therapy* (ORT), as described in details later in this very Chapter, is ideal for mild dehydration and a majority of the children with moderate dehydration. One may use the standard WHO ORS, one of its modifications, or a home-made electrolyte solution (HES). There are distinct advantages in using a cereal-based solution such as ricewater electrolyte solution (RWESD), especially since it has a better tolerance and provides greater energy.

Each motion must be followed by replacement with an equal amount of ORS. Breastfeeding must not be discontinued. In fact, it potentiates the usefulness of ORT.

2. *Intravenous fluid therapy* is indicated in cases with severe dehydration (Fig. 24.2) and those who fail to retain ORS persistently. It consists of “deficit” and “maintenance” therapy.

Table 24.6: Assessment of diarrheal dehydration as per WHO

Area of clinical observation	Actual observation(s)		
	No dehydration	Some dehydration	Severe dehydration
General condition	Well. alert	Restless, irritable	Lethargic, unconscious
Eyes	Normal	Sunken	Sunken
Thirst	Drinks normally, not thirsty	Drinks eagerly, thirsty	Drinks poorly, unable to drink
Skin pinch	Goes back quickly	Goes back slowly	Goes back very slowly

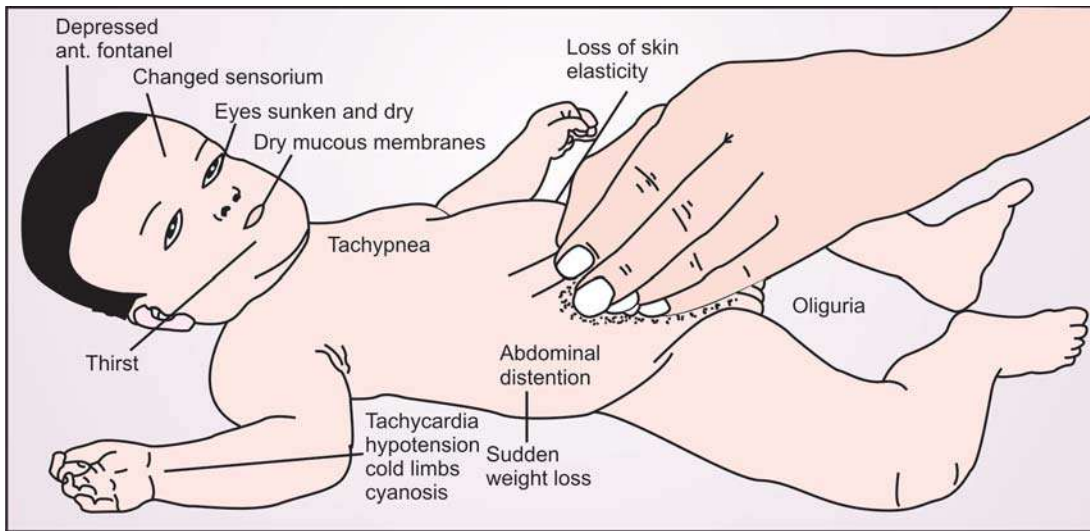

Fig. 24.2: Severe diarrheal dehydration. Note the classical features

Deficit therapy A particular grade of dehydration, moderate for instance, may mean variation between 5 to 10% weight loss. It is, therefore, rather unrealistic to administer the same amount of fluid to all such children. Table 24.7 gives a modification of a popular scoring system. It has yielded gratifying results in our as well as others experience in managing dehydrated infants and children.

Table 24.7: Dehydration scoring system	
Score 1	Score 2
1. Irritability, drowsiness, or lethargy	1. Shock/coma
2. Sunken anterior fontanel and/or eyes	2. Acidosis
3. Dry mucous membrane and/or skin	3. Anuria
4. Loss of skin turgor	4. Moribund state
5. Abdominal distention	
6. Tachycardia	
7. Oliguria	

The deficit therapy is obtained by the following:

$$\text{Score} \times \text{weight in kg} \times 10$$

Thus, an 18-month-old, weighing 10 kg and scoring 8 points (8% dehydration or weight loss) requires $8 \times 10 \times 10 = 800$ ml of fluids to cover the deficit as a result of dehydration.

Maintenance therapy It is best calculated as already outlined in Chapter 16. Thus, again taking up the just-cited example, this 18-month-old needs $125 \times 10 = 1,250$ ml of fluids/24 hours (Table 24.8).

Plan of therapy Different centers employ different plans. The following lines of administering the fluids is generally favored* (Fig. 24.3).

* The vast majority of pediatric dehydration in India is "isotonic". The regimen is, therefore, by far the best in our set-up.

- i. **Initial therapy** Of the total fluids calculated for 24 hours, one-fifth is given rapidly in the form of Ringer lactate in 2.5 or 5% glucose during the first 1 to 2 hours*.

If anuria persists despite rapid flushing in of the IV fluids, a bolus dose of frusemide may be administered. If the child passes urine, the IV drip is continued. Else, the child is treated as for acute renal failure, reducing the fluid intake considerably.

- ii. **Continuation therapy** For rest of the 24 hours, remaining four-fifth fluid is administered slowly. Here, half strength Darrow solution which is relatively rich in potassium is ideal. The aforesaid plan of fluid therapy works well in a vast majority of the cases. It takes care of potassium deficiency as well as acidosis. Complications such as metabolic acidosis, paralytic ileus or hypocalcemic tetany are rare with this regimen.

Maintenance of fluids and electrolytes should continue over the second 24 hours even if diarrhea has stopped in the very first 24 hours.

In severe acidosis ($\text{CO}_2 < 8$ mEq/L), it is advisable to give additional alkali (which should be infused) in amounts as per the following formula:

$$\text{ml of NaHCO}_3 (7.5\%) = \text{bicarbonate deficit (mEq/L)} \times \text{body weight (kg)} \times 0.5.$$

* To determine number of drops per minute apply this equation.

$$\text{No. of drops/minute} = \frac{\text{ml to be given in one hour}}{3}$$

Table 24.8: Composition of important intravenous solutions (mEq/L)

Solution	Na	K	Mg	Cl	HCO ₃
Isotonic saline (0.9% NaCl)	154	–	–	154	–
Ringer lactate	130	4	–	109	28
Half-strength Darrow solution	61	18	3	52	27
Sodium bicarbonate (NaHCO ₃ 7.5%)	892	–	–	–	892
Sodium lactate (N/6)	167	–	–	–	167

In situations where it is difficult to determine the base deficit, sodium bicarbonate may be given in the dose of 2 to 3 ml per kg.

It is advisable to review the child after 2 hours to find if further correction is needed.

4 In case of severe hypokalemia, additional potassium in the dose of 1 to 3 mEq/kg may be added to the drip. Contrary to earlier recommendation, insistence on “passing urine freely” before potassium is administered is not necessary. If possible, an ECG should be done. In the event of occurrence of

hyperkalemia, exchange resins, or digoxin are of value. IV NaCl and Ca are also helpful.

For hyponatremia, full strength electrolyte solutions and even 3% NaCl may be used.

Significant hypernatremia requires solutions with sodium content of around 30 mEq/L. Highly diluted solutions may cause convulsions and other neurologic manifestations. Rarely, very serious cases of hypernatremia may need peritoneal dialysis as is done in the case of acute renal failure.

Finally, it needs to be remembered that plain solutions, like 5% glucose, should never be used for intravenous of dehydration correction.

The World Health Organization (WHO) recommendations on the management of acute diarrhea in infants and children are given later in this very chapter.

B. WHO Guidelines on Management of Diarrheal Dehydration

Plan A for “No dehydration”

Objective: Prevention of dehydration

It is carried at home and consists of

- ORS administration, in amounts exceeding normal requirements

< 6 months	50 ml (1/4th glass)
7 months – 2 yr	50-100 ml (1/4 – 1/2 glass)
2 yrs – 5 yr	100 – 200 ml (1/2 – 1 glass)
Later	As much as the child accepts
- Continuing normal feeding
- Asking the caretaker to bring back the child after 2 days (even earlier in the presence of such danger signals (fever, repeated vomiting, dehydration, blood in stools))

Plan B for Some Dehydration

Objective: Correction of dehydration and prevention of malnutrition

- Correction of dehydration is carried out by administering ORS, 75 ml (50-100 ml)/kg over a period of 4 hours.
- Continuing breastfeeding /other feeding
- Reassessment after 4 hours.
 - If adequately rehydrated, deal as in Plan A
 - If poor response to ORS, treat as in Plan C.

Plan C for Severe Dehydration

Objective: Quick correction of severe dehydration with IV fluids (preferably Ringer’s lactate) in a hospital

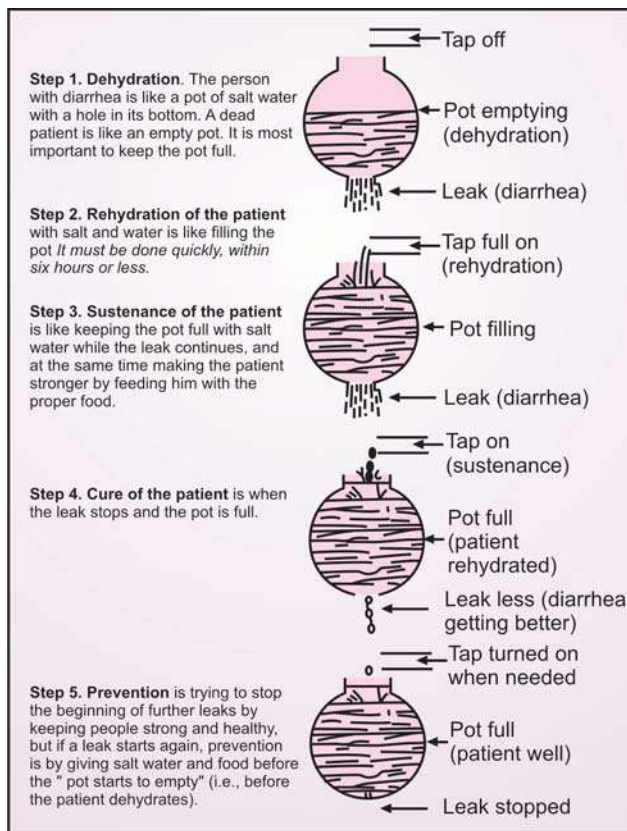

Fig. 24.3: The five steps of diarrhea and its management

- < 1 yr 30 ml/kg within first hour followed by 70 ml/kg over next 5 hours
- >1 yr 30 ml/kg within ½ hour followed by 70 ml/kg over next 2 ½ hour.
- Assess every 1-2 hour
 - If no improvement, give IV fluid more rapidly
 - If improvement, complement with ORS as soon the infant starts accepting it.
 - After 6 hours in infants and 3 hours in older children, opt for the suitable plan A, B or C depending on the assessed hydration status.

C. Chemotherapy (Table 24.9)

Bacterial or parasitic organisms are not isolated from the large majority of pediatric patients suffering from acute diarrheal disease. Routine use of chemotherapeutic agents is, therefore, generally not favored by the experts. However, chemotherapeutic cover may be indicated in patients in whom diarrhea is known or is strongly presumed to be bacterial/protozoal. Table 24.9 summarizes the recommendations of the Indian Academy of Pediatrics, appropriately updated, in this behalf.

Ampicillin is by far the best and the drug of choice in severe gastrointestinal infections. The dose is 50 to 100 mg/kg/day (divided doses). It may be given orally, intramuscularly or intravenously. It is bactericidal, and safe. Diarrhea due to *Shigella*, *Salmonella*, *E. coli*, *Staphylococcus* and *Streptococcus*

promptly responds to this broadspectrum semisynthetic penicillin. Unfortunately, ampicillin, given orally, is not well tolerated by children.

Amoxycillin, 20 to 40 mg/kg/day in 3 divided doses, claims to be marginally superior to ampicillin.

Furazolidine, a safe and potent antidiarrheal agent, effective in many Gram-positive bacterial species and strains. It is also effective in diarrhea associated with giardiasis. The dose is 8 mg/kg/day (divided doses) with a maximum of 200 mg. It is contraindicated in the newborn owing to the potential risk of G-6PD deficiency leading to hemolytic anemia. It is available for oral administration only.

Cotrimoxazole, having a very wide spectrum of activity, may be employed with gratifying response in bacterial diarrhea. The dose is calculated on the basis of 4 to 10 mg/kg/day of trimethoprim.

Nalidixic acid, 50 mg/kg/day in 4 divided doses, is of considerable value in *Shigella* and *E. coli* infections of the gut.

Erythromycin, 30 to 50 mg/kg/day in 4 divided doses, is effective in diarrhea due to *Campylobacter jejuni* and *Vibrio cholera*.

Norfloxacin, 4-12 mg/kg/day in 2 divided doses, and *ciprofloxacin*, 10-30 mg/kg/day in 2 divided doses, though very effective, need to be judiciously used in infants and small children.

With regard to chemotherapy of diarrhea due to protozoa, *Entamoeba histolytica* and *Giardia lamblia*, see Chapter 20 (Pediatric Parasitosis).

Table 24.9: Updated Indian Academy of Pediatrics (IAP) recommendations on chemotherapy for bacterial and protozoal diarrhea

Etiologic agents	Chemotherapy	Remarks
<i>Shigella</i>	Nalidixic acid, cotrimoxazole, ampicillin	
<i>Enteroinvasive E. coli</i>	Nalidixic acid, cotrimoxazole Ampicillin, inj gentamicin (in case of septicemia)	
<i>Salmonella</i>	Ampicillin, chloramphenicol	Chemotherapy indicated — infants under 6 months — immunocompromised infants — clinical suspicion of bacteremia
<i>Campylobacter jejuni</i>	Erythromycin, furazolidin Chloramphenicol, gentamicin	Use of chemotherapy not indeed necessary since it is self-limiting infection
<i>Vibrio cholerae</i>	Furazolidine, cotrimoxazole Tetracycline, erythromycin,	
<i>Ent. histolytica</i>	Metronidazole, tinidazole, secnidazole paromomycin	
<i>L. giardia</i>	Metronidazole, tinidazole, secnidazole, ornidazole, furazolidine, albendazole	

D. Symptomatic Control

In the past, nonspecific antidiarrheal agents like codeine, morphia, tincture opium, charcoal, chalk, anticholinergic drugs, products of hydroscopic bulk (psyllium seed or plantago ovtum), kaolin, bismuth, pectin, diphenoxylate hydrochloride and loperamide hydrochloride have been used. These drugs are either not quite effective or their use is accompanied by unpleasant/untoward side-effects. These are no longer recommended.

The role of prostaglandin inhibitors and antisecretory agents such as aspirin, though theoretically significant, needs detailed evaluation in the therapy.

E. Diet

4 Prolonged "starvation" damages rather than helps and should be discouraged. Even hypocaloric oral therapy during an episode of diarrhea and vomiting may lead to severe malnutrition. Lack of attention to nutrition during diarrhea appears to be the largest contributor factor to overwhelming problem of malnutrition in the Indian subcontinent.

Banana, apple pulp, yoghurt, curd, potatoes, rice, wheat, etc. should be given as soon as possible. Foods rich in fats or sugar, including juices and soft drinks, should be avoided.

Current recommendations on nutritional management of acute diarrhea are as follows:

- Since most nutrients are well-absorbed during diarrhea and since diarrhea predisposes to malnutrition, it is safe and desirable to continue breastfeeding as also other feeding during a diarrheal episode. That rest to gut promotes early recovery is no longer held true. It has no physiologic basis at all.
- Optimally energy-dense foods with minimal bulk, given in small quantities every 2 to 3 hours, promote better nutrition.
- Since staple foods do not provide optimal calories per unit weight, these are best enriched with richer sources of energy like fats and oils, e.g. *Khichri* with oil, rice with milk or curd, mashed banana with milk or curd, mashed potato with oil etc.
- Foods with high fiber content (coarse fruits and vegetables) as also soft drinks and juices with very high sugar content may be avoided during an acute diarrheal episode.

- In artificially-fed infants, milk should preferably be given undiluted during all phases of acute diarrhea. If the infant is over 4 months, milk cereal mixture (say dalia-sago, rice-milk) is strongly recommended.
- Transient lactose intolerance, which is frequent in acute diarrheal disease, does not warrant lactose-free milk unless it persists beyond 8 to 10 days and is accompanied by progressive weight loss.
- During convalescence from acute diarrhea, dietary intake should be enhanced by at least 25% of normal to make up for the losses during illness and to promote rapid weight gain until the child attains normal nutritional status.

Finally, it is most appropriate to re-emphasize the WHO/UNICEF slogan that the full package for diarrhea therapy in a vast majority of children is ORS and continued feeding.

F. Ancillary Measures

These include control of vomiting by sips of ORS, a mild antiemetic or stomach wash, and treatment of any other accompanying problem. If IV drip is to be prolonged, vitamins should be added to the infusion.

It is advisable to restore the normal intestinal flora (lactobacilli) which may be destroyed by the disease or by antibiotic therapy by administering a preparation containing lactobacillus strains.

Abdominal distention, if mild and with normal bowel sounds, warrant no intervention. Paralytic ileus, manifested by gross abdominal distention and poor or absent bowel sounds, is an indication for temporary withdrawal of oral feeds, intermittent nasogastric suction and administration of potassium chloride with a parenteral fluids. The existence of septicemia or enterocolitis should be seriously considered and treated energetically.

Zinc, 20 mg/day (O), in every child with diarrhea, for 2 weeks is recommended by the IAP.

Seizures during acute diarrhea may result from several factors, namely fever, hypo- or hypernatremia, hypoglycemia, hypocalcemia (consequent upon administration of bicarbonate for correction of acidosis), meningitis, encephalitis, cavernous sinus thrombosis, etc. After symptomatic control of seizures with IV diazepam or another suitable anticonvulsant

has been attained, attention should be paid to treat the etiologic basis of seizures.

Prognosis

- i. *Age*: Mortality is higher in newborns and infants than in older children.
- ii. *Nutritional status*: Diarrhea in malnourished children carries poor prognosis.* Even mild to moderate diarrhea in such subjects may cause almost irreversible metabolic alterations, causing death. In one investigation, while the mortality in well-nourished patients was 4.3%, it was 22% in those suffering from marasmus.
- iii. *Causative organism and severity of illness*: *E. coli* resistant to most available antibiotics and *Shigella* cause very severe illness.
- iv. *Associated illness/complications*: Presence of profound dehydration, electrolyte imbalance or bronchopneumonia definitely has adverse effect on the outcome.
- v. *Management*: Promptness and adequacy of treatment also have great bearing on the ultimate outcome.

Prevention

- i. *Improvement in the nutritional status* of the children. Malnutrition predisposes to diarrhea which further aggravates the state of poor nutrition.
- ii. *Improvement in community's water supply*, sanitation and hygiene. Mothers must ensure proper hand washing before serving, preparing or eating food, using clean (potable), preferably boiled or filtered, drinking water, protecting food from contamination by flies, cockroaches and dirt, washing fruits and vegetables before use, and proper disposal of excreta (Fig. 24.4).
- iii. *Breast (biological) feeding should be encouraged* Those who are bound to stick to artificial feeding should learn the hygienic preparation of the formula and care of bottle, teats, etc.

* Children with significant PEM often suffer from hypotonic dehydration. This observation is in sharp contrast with the picture seen in other children in whom dehydration is usually of isotonic type. Malnourished children, should, therefore, receive:

- i. Either isotonic or even hypertonic solution.
- ii. Additional potassium.
- iii. Additional sodium bicarbonate or sodium lactate to combat severe acidosis.
- iv. Relatively less amount of fluids.

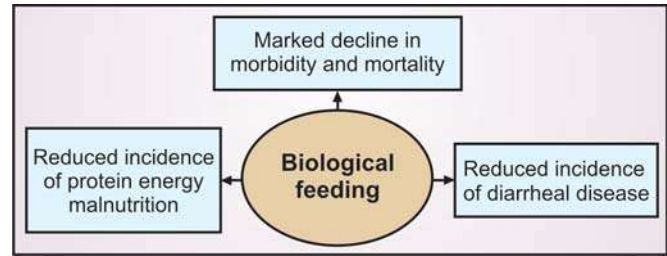

Fig. 24.4: Major gains of biological feeding

- iv. Mothers must be taught when to *consult the doctor* in case of diarrhea.
 - v. Standardized simple method of administering intravenous fluids should be available not only in the cities but in rural areas as well.
 - vi. Easy availability of “take home” ORS sachets
 - vii. *Rotavirus vaccine* An oral tetravalent rotavirus vaccine against all four major serotypes incorporating RRV and reabsorbent viruses (human serotype G1, G2 and G4) in a single vaccine is now available.
- ETEC vaccine and cholera vaccine are available whereas a live shigella vaccine is round the corner.

Complications/Sequelae

- Dehydration with its widespread complications, including renal shutdown, paralytic ileus, thromboembolism, seizures.
- Superadded infections including thrombophlebitis at the site of cutdown.
- Overhydration and CCF.
- Malnutrition.
- Hypoglycemia.
- Syndrome of inappropriate secretion of antidiuretic hormone (ADH).
- Carbohydrate intolerance and chronic diarrhea.
- Subdural collection of fluid/blood that may possibly cause mental retardation in later life.
- Consumptive coagulopathy.
- Toxic megacolon.

CHOLERA

This is a form of severe gastroenteritis characterized by sudden onset of profuse effortless watery diarrhea followed by vomiting and severe dehydration. The severest form of cholera is termed “cholera gravis”.

Etiology

The causative agent is labeled as *Vibrio cholerae* 01 or *V. cholerae* 0139 Group 1. The classical biotype is now

by and large replaced by the E1 T or biotype mostly belonging to the serotype Ogawa.

In addition to the known 138 serotypes of *V. cholerae*, a new serotype (non-01) identical to the Indian serotype has been identified in Bangladesh. It behaves like *V. cholerae* 01 in causing a severe disease through production of a large quantity of cholera toxin.

Epidemiology

Though epidemics are now infrequent (the July-August 1988 outbreak in Delhi and other parts of the country was the most remarkable in the recent decades), cholera is currently endemic in Maharashtra, Tamil Nadu, Madhya Pradesh, Andhra Pradesh and Assam. These States account for 80% of the total incidence in India. Bengal is no longer considered as the home of cholera.

The disease is transmitted by the feco-oral route, the channels of transmission being contaminated water, contaminated foods or drinks, or direct person-to-person contact. Poor environmental sanitation thus, constitutes the lifeline for spread of cholera.

Clinical Features

Incubation period is 1 to 2 days with a variation of few hours, to 5 days.

Clinical picture shows the following three stages:

1. *Stage I* (Stage of evacuation) is characterized by profuse, effortless watery diarrhea with rice-water appearance (as many as 50 motions/day) followed by vomiting and rapidly developing dehydration.
2. *Stage II* (Stage of collapse) is characterized by severe dehydration, eventually ending up in shock which may prove fatal.
3. *Stage III* (Stage of recovery) is characterized by signs of clinical improvement in subjects who have escaped death.

Diagnosis in suspected cases needs to be confirmed by:

1. Direct microscopy of samples of stool, vomitus, water or food. Under dark field illumination, organisms appear as several shooting stars in a dark sky.
2. Culture on peptone water tellurite (PWT) medium.
3. Biochemical tests.

Complications

These include acute renal shutdown, hypokalemic nephropathy, paralytic ileus, pulmonary edema and arrhythmias.

Management

Treatment consists in administering oral and/or intravenous rehydration therapy along with chemotherapy to cut short the duration of disease as also to reduce period of vibrio excretion. Drug of choice is tetracycline but, in view of its known adverse side-effects in children, the choice should be out of erythromycin, furazolidine, ciprofloxacin and cotrimoxazole. A 3-day course is sufficient. Whereas *V. cholerae* 0139 is resistant to cotrimoxazole, tetracycline-resistant strains of *V. cholerae* 01 have also occurred in many countries.

Attention must also be directed to sanitation measures such as water control, excreta disposal, food sanitation and disinfection. The innovative "cholera cot" developed by the Diarrheal Disease Center, Dhaka, Bangladesh, is of great utility. It is a portable cot with a hole in the middle, leading to a bucket underneath.

Prophylaxis

Chemoprophylaxis (same drugs as for treatment and for the same period) is recommended for household contacts or for a closed community with outbreak of cholera.

Cholera vaccine (killed; 12,000 million vibrio/ml) has a protective value of 50% for a period of 3 to 6 months. However, once an epidemic has occurred, it is virtually of no value. On the other hand, it may contribute to additional problems such as outbreak of serum hepatitis and poliomyelitis.

Dose is 0.3 ml for children above 2 years and 0.2 ml for those between 6 months to 2 years. It is given subcutaneously and repeated after an interval of 4 to 6 weeks. Reactions include local pain, swelling, erythema and abscess. Fever occurs only in a small proportion of cases.

Oral live attenuated vaccine is still in experimental stage.

ACUTE BACILLARY DYSENTERY (*Shigellosis*)

It is defined as passage of loose stools containing mucus, pus and blood, and accompanied by fever, tenesmus and crampy abdominal pain.

Etiopathogenesis

The causative organism, *Shigella*, is subdivided into 4 groups:

Group A : *Shigella shiga* or *dysenteriae* is the most important among the 10 serotypes.

Group B : *Shigella flexneri* or *paradysenteriae* is the most important among the 6 serotypes.

Group C : *Shigella boydii*

Group D : *Shigella sonnei*

Invasive strains of shigella, after penetrating the epithelial cells of the intestine, multiply in the submucosa and lamina propria. This leads to local inflammation and superficial ulcers which may bleed.

Epidemiology

Shigellosis occurs worldwide, usually towards the late summer.

The disease spreads chiefly by oral-fecal route. The spread is boosted by the low level of personal hygiene, environmental sanitation level causing breeding of flies, and contamination of water, ice, milk and other foods. Both sporadic and epidemic forms occur.

Clinical Features

Incubation period is usually 1 to 3 days.

Onset is sudden with fever, prostration, vomiting, bloody diarrhea, abdominal pain and tenesmus. Dehydration and electrolyte loss may cause shock. Headache, drowsiness and even coma, neck rigidity and convulsions may occur.

Differential Diagnosis

Table 24.10 lists the major differential diagnosis of bloody diarrhea in children.

Table 24.10: Major differential diagnosis of bloody diarrhea

Invasive bacteria	<i>Shigella</i> , <i>E.coli</i> (enteroinvasive, enterohemorrhagic, <i>Campylobacter jejuni</i> , <i>Salmonella</i> (nontyphoidal)
Protozoa/helminths	<i>Ent. Histolytica</i> (both luminal and invasive), <i>L. giardia</i> , <i>H.nana</i> , <i>Strong. Stercoralis</i> , hookworm
Miscellaneous/ noninfectious	Intussusception, vitamin K deficiency, ulcerative colitis, Crohn disease, blood dyscrasias (leukemia), purpura (ITP, Henoch-Schoenlein purpura)

Diagnosis

Stool sample shows leukocytes (pus cell) and red blood cells.

Blood counts reveal a marked leukocytosis with rise of polymorphonuclear cells in majority of the cases.

Stool cultures for isolating the organism are essential for establishing the diagnosis.

Treatment

Choice of antibiotic depends on the existing sensitivity of the organism in the particular community. The strains are usually responsive to ampicillin, cotrimoxazole, nalidixic acid or tetracyclines. The last-named should be reserved for only grown-up children.

General measures include correction of dehydration and electrolyte imbalance and associated malnutrition, including hypoproteinemia and anemia. Antimotility drugs such as diphenoxylate and loperamide may decrease frequency of motions but prolong excretion of *Shigella*, and are best avoided.

Prognosis

Institution of proper treatment well in time leads to a favorable prognosis in a large majority of the cases. Such factors as malnutrition and enclosed population (say, that of mental institution) contribute to increased morbidity and mortality.

Complications include anemia with hypoproteinemia, rectal prolapse, arthritis, Reiter syndrome, vaginitis and hemolytic uremic syndrome. A chronic form of shigellosis may occur. In such a carrier state, a synthetic derivative of lactose (*Lactulose*) may transiently reduce the excretion of the organisms.

Prevention

This is by control of carrier and active states and attention to personal, water and food hygiene and environmental standards. No vaccine is so far available against shigellosis.

PSEUDOMEMBRANOUS COLITIS (*Clostridium difficile*-associated Diarrhea)

This serious diarrheal state is due to the toxin produced by toxigenic *Clostridium difficile*, a gram-positive anaerobic bacillus that is normally found in 3% of adults, 50 to 70% of neonates and 20 to 50% of infants.

Etiopathogenesis

Table 24.11 lists the important predisposing factors for pseudomembranous colitis.

The causative organism, *C. difficile*, is not invasive. Its toxigenic strains cause pseudomembranous colitis by producing toxins A and B. The toxins perhaps produce diarrhea by causing inflammation, loss of proteins, exaggerated peristalsis, hemorrhage, enhanced fluid and electrolyte secretions, or cytotoxicity.

Table 24.11: Factors predisposing to pseudomembranous colitis

Drugs: Ampicillin, penicillin, cephalosporins, amoxicillin, clindamycin, methotrexate, antiviral agents
Intestinal motility disorders; Hirschsprung disease
Uremia
Anesthesia
Dietary changes

Typically, pseudomembranous nodules or plaques occur in rectum, sigmoid and distal colon. In a proportion of cases these may be found only in cecum and transverse colon. The lesions appear as grayish-white exudates that are surrounded by edematous and erythematous inflammatory response. These are poorly adherent to the underlying tissue.

Clinical Features

Manifestations include mild watery-green diarrhea with cramps (mild illness) and severe hemorrhagic colitis with protein-losing enteropathy, hypalbuminemia, shock, pyrexia, abdominal distention and tenderness, toxic megacolon, colonic perforation, peritonitis and sepsis (severe illness).

In antibiotic-associated pseudomembranous colitis, symptoms usually occur on 4 to 8th day of antibiotic therapy. Occasionally, these may occur on an average 5 days after withdrawal of antibiotic therapy.

Diagnosis

A high index of suspicion is vital in detecting cases of pseudomembranous colitis.

The diagnosis needs detection of the organism, *C. difficile* (culture) as also the toxin A (ELISA or latex agglutination assay) and toxin B (cytotoxicity to cultured fibroblasts).

Colonoscopy may be of value in visualizing the lesions in atypical cases.

Differential Diagnosis

Differential diagnosis is from antibiotic-associated colitis, diarrhea due to *Shigella*, *Salmonella*, *E. coli*, *Yersinia*, *Helicobacter*, *Ent. histolytica*, *L. giardia*, *Strong. stercoralis*, *Trich. trichiura*, or *H. nana*, HUS, inflammatory bowel disease (Crohn's disease, regional ileitis), neutropenic colitis, typhilitis, and malabsorption states.

Treatment

Discontinuation of the suspected drug and rehydration therapy, if dehydration is present, results in remarkable improvement within 48 hours and complete resolution within 7 to 10 days in mild cases.

Oral vancomycin (20 to 40 mg/kg/day) or oral metronidazole as antimicrobial therapy against *C. difficile* is indicated in subjects not responding to the above therapy within 48 to 72 hours and those who are having severe illness. In yet more critical situations (toxic mega-colon, adynamic ileus), a combination of the two drugs intravenously is recommended.

Prognosis

Recurrences may occur in a proportion of the cases. Oral cholestyramine, bacitracin, immune globulin, lactobacilli, baker's yeast or instillation of fecal flora may work in such subjects.

ORAL REHYDRATION THERAPY (ORT)

Oral rehydration means drinking a solution of clean water, sugar and mineral salts to replace the water and salts lost from the body during diarrhea, especially when accompanied by vomiting, the so-called *gastroenteritis*. Studies conducted all over the world, particularly in Bangladesh, India and Indonesia, have established the value of this "revolutionary concept" in counteracting dehydration which is known to be the main cause of death in acute diarrheal disease, a major public health problem.

ORS is now distributed internationally by the UNICEF in packets labeled Oral Rehydration Salts (ORS) and also manufactured commercially by several pharmaceutical houses for sale on prescription.

Indications

ORT is beneficial in three stages of diarrheal disease, namely:

- *Prevention* of dehydration if initiated right at the beginning of an episode of diarrhea
- *Rehydration* of the dehydrated child so that he does not enter the phase of severe dehydration in which intravenous fluids may become necessary
- Maintenance of hydration after severely dehydrated patient has been rehydrated with intravenous administration.

Standard Formulation

The standard formulation, recommended by *World Health Organization* until recently has an osmolarity of 311 mmol (Table 24.12).

Low Osmolarity ORS

Recently, WHO has done well to introduce a low osmolarity ORS to cut down risk of hyponatremia which earlier restricted its wide usage in neonates and infants. This formulation provides a total osmolarity of 245 mOsm/L compared to the standard WHO formulation with 311 mOsm/L. It is supposed to lower stool output, shorten diarrheal duration and reduce vomiting. It may be given at all ages. The Indian Academy of Pediatrics (IAP) has pleaded for easy availability of yet lower osmolarity ORS (224 mOsm/L) for infants < 2 months.⁵

Table 24.12: Low osmolarity ORS vis-avis standard ORS

Component	Standard ORS	Low osmolarity ORS
<i>Contents</i>		
Sodium chloride	3.5 g	2.6 g
Sodium bicarbonate (citrate)	2.5 g (2.9 g)	2.9 g
Potassium chloride	1.5 g	1.5 g
Glucose	20.0 g	13.5 g
<i>Osmolarity</i>		
Sodium Chloride	90 mmol	75 mmol
Citrate	80 mmol	65 mmol
Potassium	10 mmol	10 mmol
Glucose	80 mmol	20 mmol
Total osmolarity	311	245

Replacement of sodium bicarbonate by trisodium citrate dihydrate (2.9g) undoubtedly enhances the shelf-life of the ORS but also makes it more expensive. The ORS thus prepared provides 10 mmol/L of citrate in place of 30 mmol/L of bicarbonate (one mmol citrate = 3 mmol base)

ReSoMal (ORS in Severely Malnourished Children)

ORS for severely malnourished children needs to be special in order to provide high potassium and low sodium. WHO recommends ReSoMal for this purpose. Though commercially available, it can be prepared by diluting standard WHO ORS in 2 liters of water rather than one liter and adding 50 g sucrose (in place of 20 g) and 40 ml of mineral mix which, among other minerals, provides high content of potassium chloride. This solution is administered in a dose of 70-100 ml/kg over 12 hours (Fig. 24.5).

Home-made Preparations of ORS

Several studies with home-made preparations as also our own experience with them have given gratifying results.

How to make ORS at home? The easiest approach is to mix one three-finger-pinch (1/2 teaspoonful) of common salt and two four-finger-scoops (5 teaspoonfuls) of sugar in one liter of tap or boiled water. Addition of lemon or orange juice, coconut water, mashed tomato, papaya or banana to this solution brings it close to the recommended WHO formulation. Even if none of these can be procured, it does not matter. It has been demonstrated that potassium and bicarbonate may not be essential in the early stages of dehydration. Also, there is nothing wrong in replacing sugar or glucose with molasses (*gur*) (Fig. 24.6).

Substituting a polymeric form of glucose (starch) of the WHO ORS for the single molecule form results in solution that may perform better than the standard ORS. Hence the designation super "ORS". This has led to the concept of cereal-based ORT (Table 24.13), the best studied so far being rice water electrolyte solution. Rice-water electrolyte solution (RWES) consists of decanted solution after cooking rice. Salt is added to it. This may also be prepared by dissolving 2-finger scoops of rice powder (boiled rice) in water and boiling for 3 minutes. To it are added a pinch or two of salt and 1/4th medium size lemon juice.

Table 24.13: Advantages of cereal-based ORT

- More palatable
- Provides more energy
- Reduces stool volume; hence less diarrheal fluid losses
- Controls/lessens vomiting during treatment
- Shortens duration of diarrhea
- Ingredients (cereals, starchy vegetables) easily available in households

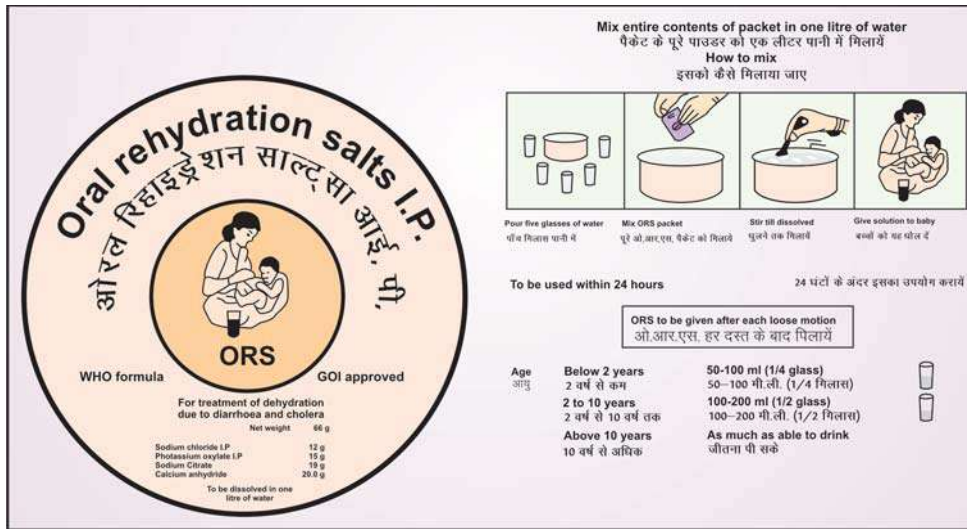

Fig. 22.5: Oral Rehydration Salts (ORS) sachets must bear logo and instructions for use as shown here

4

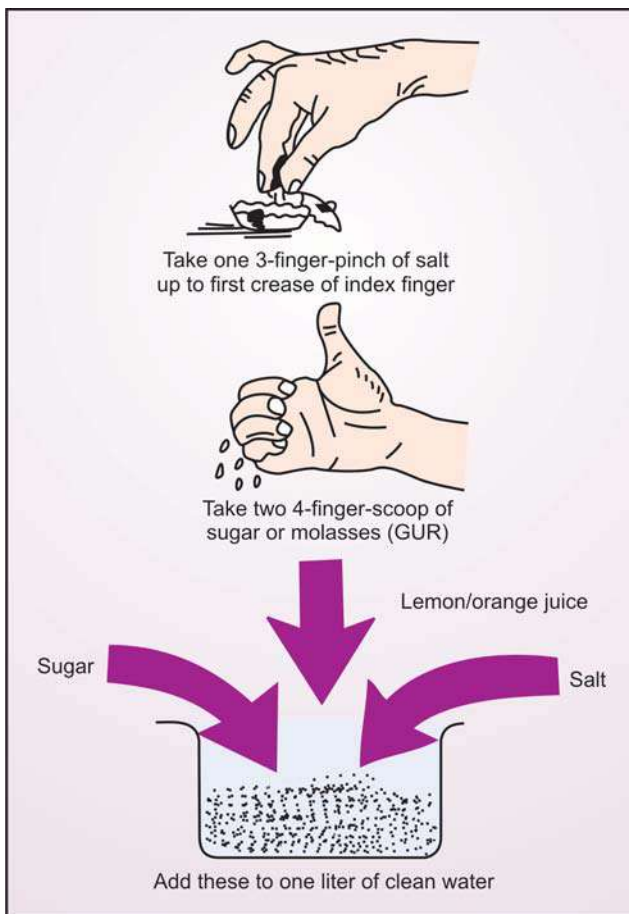

Fig. 22.6: Preparing ORS at home

RWES is more palatable. Babies not responding to the standard ORS may respond to it.

Alternative home-made electrolyte solutions (HES) include:

1. *Daal* and water solution, carrot juice, tender coconut water, Bengal gram kanjee, weak tea, fruit juices, banana.
2. Honey-based: One teaspoonful of honey + pinch of salt + one glass water.
3. Arrowroot kanjee + salt.
4. Butter milk + salt + with or without sugar and lemon.

Since diarrhea and vitamin A deficiency are beginning to be considered as risk factors for each other, fortification of ORS with vitamin A, or, at least, linkage of distribution of vitamin A and ORS sachets has been advocated. This may prove an effective strategy reducing the morbidity accompanying diarrheal dehydration and vitamin A deficiency.

Administration

Ideally, each motion should be followed by replacement of as much fluids. Illiterate mothers, however, may not be able to judge the amount of fluid loss. In such cases, let them give the child as much ORS as he desires. But, it is unwise to push the fluids if the child does not accept these or if vomiting is persisting. Giving ORS in sips often helps to tide over this difficult situation.

Limitations

- A common criticism of standard ORT is that it may cause hypernatremia, resulting in convulsions, cerebral hemorrhage and often death. The availability of low osmolarity ORS

In any case, WHO recommends that it is of advantage to continue breastfeeding during ORT or, in its absence, to give the child one cup of additional water along with every two cups of standard ORS. Alternatively, the standard WHO ORS may be made in 1.5 liters rather than 1 liter of water. This is a good safeguard against risk of hypernatremia. Though experience with ORT in neonates is rather limited, it has been recommended that supplementation of the WHO formula with additional fluids proves safe in them.

- Glucose malabsorption may occur in a small proportion of cases, thereby worsening the diarrhea and dehydration.
- ORT may not be the answer in a proportion of the cases with severe dehydration leading to shock, anuria and acidosis. It may also flop in severe vomiting and high rate of stool loss.

ORT as a Community-based Program

All said and done, ORT deserves to be integrated with family welfare or planning as part and parcel of Maternal and Child Health (MCH) Program in India and other developing countries. This is what the WHO is trying to do now.

PERSISTENT DIARRHEA

Definition

The term, *persistent diarrhea*, is employed when an episode of acute diarrhea continues beyond 2 weeks period. According to conservative estimates, some 7 to 25% children in preschool age group who suffer from acute gastroenteritis may end up with persistent diarrhea in the developing countries such as ours. Peak incidence is around 1 year of age. It contributes considerably to malnutrition. In subjects under 1 year, mortality is particularly high.

When persistent diarrhea has its onset before the age of 3 months, it is often termed **intractable diarrhea of infancy**.

Etiology

Persistent diarrhea is as yet an entity of obscure etiology. Identifiable risk factors include:

- Age between 6 months to 1 year; after 2 years of age, risk of persistent diarrhea is reduced.
- Low birthweight and malnutrition; vitamin A deficiency.
- Diarrheal episode with blood and mucus such as caused by enteropathogenic or aggregative adherent *E. coli*, *Shigella*, *Salmonella*, *Campylobacter jejuni*, and rotavirus, especially in infants less than 3 months of age.
- Excessive fluid intake, especially carbonated drinks and fruit juices.
- Artificial feeding.
- Indiscriminate use of ORS, especially with high sugar content.
- Lactose intolerance.
- Systemic infections like septicemia.
- Milk protein allergy.
- A preceding diarrheal episode in the recent past may make the child vulnerable to yet another episode that becomes persistent. The factors that contribute to persistent diarrhea in such a situation include deterioration in nutritional status, damage to small intestinal mucosa, contamination of animal milk and osmotic diarrhea.
- Intestinal parasitosis

Clinical Features

Three clinical types are recognized:

1. Subjects with several motions/day but without any adverse fallout on nutritional status and growth and development.
2. Subjects with several motions (without dehydration), and malnutrition and growth retardation
3. Subjects with several motions and dehydration that is difficult to control by ORS.

In the subjects belonging to the second and third categories, manifestations include progressive weight loss, malnutrition, anorexia, malabsorption and secondary infections.

Diagnosis

It is by and large clinical with support from screening laboratory tests. The latter must include meticulous stool microscopy, on at least 6 successive days for ova and cysts. A stool culture is warranted. An acidic diarrheal stool is an indication for demonstration of reducing substances in stools, a highly fatty stool for

fat balance studies, persistent diarrhea with recurrent chest infection for sweat chloride and persistent diarrhea with skin lesions for serum zinc level.

Treatment

Dietary manipulation along with rehydration therapy is the backbone of management of persistent diarrhea. Breastfeeding must continue. Though diarrhea may continue despite breastfeeding, infant's nutrition remains maintained and he may even gain some weight.

In case persistent diarrhea is mild, the infant on artificial feed (Tables 24.14 and 24.15) should be given milk mixed with a cereal or curd rather than milk as such.

In case persistent diarrhea is severe, as manifested by dehydration, high purge rate (over 7 mg/kg/hour) or very frequent large and watery stools, total milk elimination in an artificially fed infant is needed.

Table 24.14: Composition of an initial milk-rice diet for persistent diarrhea

Ingredient	Amount (g)
Puffed rice	12.5
Milk	40.0
Sugar	2.25
Oil	2.0
Water	to make 100.0
Egg density	96 Kcal/100g
Protein	10.0%
Carbohydrate	55.87%
Lactose	1.73%
Fat	33.9%
Amino acid score	1.0%

Note: Puffed rice is ground and appropriate quantities are mixed with sugar and oil. Boiled water is then added to make a thick gruel. This feed has a shelf life of around 3 hours

Table 24.15: Composition of an egg-based milk-free diet for persistent diarrhea

Ingredient	Amount (g)
Puffed rice	13.5
Egg	11.0
Sugar/glucose	3.5
Oil	3.5
Water	to make 100.0
Egg density	92.2 Kcal/100g
Protein	9.5%
Carbohydrate	56.9%
Fat	33.29%
Amino acid score	1.0%

Note: Egg white is added to the mixture of weighed rice, sugar and oil. Boiled water is added to make a thick gruel weighing 100 g

Breastfeeding, reduced intake of other milk, or its total withdrawal should be supplemented with enriched gruels like *khichri* with oil, lentil with oil, mashed potato with oil, curd mixed with mashed potatoes or banana or rice with added sugar.

In cases of severe persistent diarrhea who fail to respond to the dietary management outlined above, intolerance to disaccharides (other than lactose as well) becomes quite likely. Mono or oligosaccharide carbohydrates diet is well tolerated by these children. Table 24.16 gives details of a chicken-based diet for such a persistent diarrhea.

It is advisable to provide maintenance requirements of vitamins, and trace elements like iron, folate and zinc to infants and children with persistent diarrhea on dietary manipulation.

During convalescence, most cases need relatively higher intakes for the catch-up growth.

Antimicrobial therapy is indicated in the presence of identifiable enteric pathogens such as *Shigella* or *E. coli*, when persistent diarrhea is bloody but culture facilities are not available, and when there is evidence of persistent diarrhea being secondary to a systemic infection like septicemia. In the so-called "bacterial overgrowth syndrome", a combination of oral gentamicin (50 mg/kg/day 4 hourly for 3 days) and oral cholestyramine (lg 6 hourly for 5 days) may prove useful. Lactobacilli preparations are of doubtful value. Antimotility drugs, kaolin and pectin are best left out.

Metronidazole is recommended only for amebiasis, giardiasis, or anaerobic infections.

Table 24.16: Chicken-based diet for severe persistent diarrhea with likelihood of lactose and other disaccharide intolerance

Ingredients	Amount/liter	Kcal(%)	Protein (g%)
Chicken	100 g	110	26
Glucose	20 to 40 g	160	-
Coconut oil	40 to 50 g	450	-
KCl (15%)	7.5 ml	-	-
NaHCO ₃ (7.5%)	20 to 30 ml	-	-
Total	1000 ml	720	26

Notes:(1) It is prepared by grinding the precooked boneless chicken stuff in a mixie. Glucose, oil and some water are added to it and the feed is brought to a boil. Additional water is added to make a final volume of 1 liter. Finally, KCl and NaHCO₃ are added. To safeguard against spoilage, it is stored in a refrigerator.

(2) Glucose is initially added in 2% concentration and then built up to 4% by increasing 1% every alternate day. To reduce osmolar load, a mixture of glucose and sugar may be employed.

(3) Any vegetable oil may be employed in place of coconut oil

Algorithmic approach to management of persistent diarrhea is give in Flow chart 24.1.

Finally, parenteral nutrition (partial or total) may be indicated in very advanced cases when small bowel mucosa is extensively denuded, causing intolerance to even small amounts of gruel (which moves out in stools) with significant weight loss.

Prevention

Promotion of breastfeeding and safe weaning practices together with prompt treatment of acute diarrhea with ORS or IV fluid therapy and attention to child’s overall nutrition, during and after the diarrheal episode, should go a long way in safeguarding against development of persistent diarrhea. Starvation therapy

Flow chart 24.1: Management algorithm for presistent diarrhea

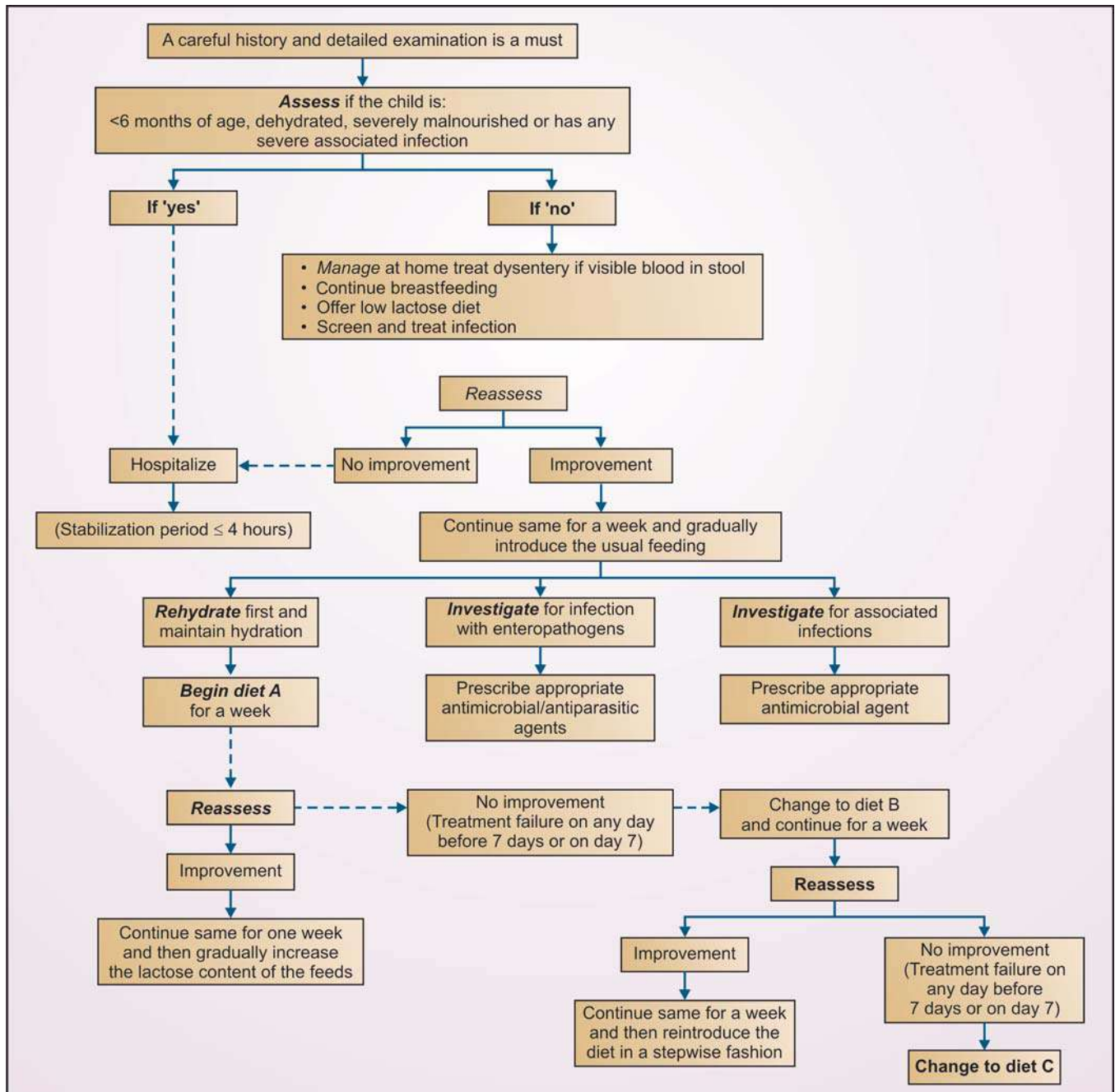

and exclusion of lactose from diet for mild transient lactose intolerance must be avoided, so should the indiscriminate use of ORS and antimicrobial therapy.

Prognosis

Inadequately treated or untreated persistent diarrhea causes high morbidity and mortality, particularly in infants. Determinants of poor outcome include systemic infections and severe lactose and/or monosaccharide intolerance. Survivors are usually left with moderate to gross malnutrition.

CHRONIC DIARRHEA

Definition

4

Chronic diarrhea is defined as “diarrhea of at least 2 weeks duration or 3 attacks of diarrhea during the last 3 months”, usually due to obvious malabsorption or an organic or other cause without obvious malabsorption.

It is a common pediatric problem in tropical countries and is responsible for considerable ill health and morbidity.

Evaluation Protocol

Roughly diagnostic evaluation of the child with chronic diarrhea should be step-by-step (Box 24.1) rather than by a large number of investigations at a time. The individual merits of each case and the proper application of knowledge and experience of the attending pediatrician contribute to deciding the necessary investigations.

Pathophysiologic Mechanisms

Osmotic diarrhea results from presence of malabsorption of water-soluble nutrients (lactose intolerance) and excessive intake of carbonated fluids or nonabsorbable solutes (sorbitol, lactulose, magnesium hydroxide) which cause an osmotic load in the colon. It shows good response to simple fasting.

Secretory diarrhea results from activation of intracellular mediators like cyclic adenosine monophosphate (cholera, heat-labile *E.coli*, *Shigella*, *Salmonella*, *C. jejuni*, *Ps. aeruginosa*, hormones like vasoactive intestinal peptide, gastrin, secretin, anion surfactants like bile acids and ricinoleic acid), cyclic guanosine monophosphate (heat stable *E.coli*, *Y.enterocolitica* and intracellular calcium (*Cl. difficile*, acetylcholine, serotonin, brady-kinin).

Box 24.1: Four phases of evaluation of the child with chronic diarrhea/malabsorption

Phase I:	History and physical examination with special reference to onset of diarrhea and its relationship with various factors (excessive carbonated drinks/fruit juices, supplementary milk feeds, cereals), specific amount of fluids ingested/day, nutritional status, etc. Meticulous stool examination (ova and cysts, pH, reducing substances, fat globules) Stool culture Stool for <i>Cl. difficile</i> toxia Blood studies (CBC, ESR, electrolytes, BUN, creatinine)
Phase II:	Fat balance studies for daily stool fat or steatocrit D-xylose test Sweat chloride test Stool osmolality and electrolytes, phenolphthalein, magnesium sulfate, phosphate Breath H ₂ tests
Phase III:	Barium meal/enema to exclude anatomic defects small intestinal biopsy/colonic biopsy by endoscopic studies Sigmoidoscopy/colonoscopy
Phase IV:	Hormonal studies Neurotransmittal studies (vasoactive intestinal polypeptide, gastrin, secretin, 5-hydroxyindoleacetic assays)

Mutation defects in apical membrane (ion) transport proteins such as in chloride-bicarbonate exchange and sodium-bile acid transporter result in secretory diarrhea and failure to thrive (FTT) at birth.

Reduction in anatomic surface area in such conditions as short bowel syndrome following surgical resection in necrotizing enterocolitis, volvulitis or atresia.

Alteration in intestinal motility in such conditions as malnutrition, diabetes mellitus, intestinal pseudo-obstruction syndromes and scleroderma. Here, diarrhea is of secretory type.

Etiologic Considerations

A large number of conditions, involving intraluminal factors, mucosal factors, or both, can cause chronic diarrhea. Nevertheless, the scene is dominated by a few conditions.

1. Is the child consuming excessive amounts of carbonated drinks or fruit juices (over 150 ml/kg/24 hours) and yet has normal growth and height parameters (nonspecific chronic diarrhea)? The problem usually resolves following reduction in fluids (under 90 ml/kg/24 hours).

2. Is the child having excessive intake of nonabsorbable nutrients such as sorbitol, $Mg(OH)_2$ or lactulose? A corrective action often controls the chronic diarrhea.

As a result of extensive studies in north India, it has become exceedingly clear that etiology of chronic diarrhea is tropical children in much different from what is described in the textbooks from the western countries. Table 24.17 gives the relative incidence of important etiologic factors. Note that the common causes occupying the top positions.

Table 24.17: The etiology of chronic diarrhea in north Indian children

Protein energy malnutrition
Iron-deficiency anemia
Excessive consumption of fluids (carbonated, fruit juices)
Intestinal parasites (<i>L. giardia</i> , hookworm, roundworm, <i>Ent. histolytica</i> , <i>Str. stercoralis</i> , <i>Trich. trichuria</i> , tapeworms)
Intestinal infection (Enteropathogens, <i>M.tuberculosis</i>)
Celiac disease
Cystic fibrosis
Endemic tropical sprue
Carbohydrate intolerance
Irritable colon syndrome
Ulcerative colitis
Miscellaneous (regional ileitis, anatomic defects, protein-losing enteropathy, etc.)

Chronic Diarrhea/ Malabsorption: A Practical Approach

The following approach is suggested for diagnosis and management of a child with chronic diarrhea and/or malabsorption in our set-up.

I. *A good history:* The importance of a carefully taken history cannot be overemphasized. Most valuable pointers and clues are likely to be obtained from answers to the following questions:

1. Did the symptoms appear early in infancy (cystic fibrosis) or after the first six months of life (celiac disease)?
2. Was there any relationship between onset of symptoms and introduction of supplementary milk feeds (lactose intolerance) or cereals (celiac disease)?
3. Is there a family history of chronic diarrhea (cystic fibrosis, celiac disease, hereditary lactose intolerance)?

4. Is there any history of intolerance to an item of food, i.e. wheat, barley, rye, oat (celiac disease) or milk (lactose intolerance)?
5. Was the child failing to thrive from early infancy or started suffering from growth failure after introduction of a solid food? The latter situation is very much suggestive of celiac disease.
6. How is the appetite? It is generally increased in cystic fibrosis and in some children suffering from giardiasis. In celiac disease, it is almost always poor. Mothers of celiacs often express surprise "as to how children who eat so little can pass such voluminous stools".
7. Does the mother feel that the child eats like a glutton but, despite all that, he has not been growing well? This strongly suggests cystic fibrosis. We have encountered this situation in some children suffering from symptomatic giardiasis as well.
8. What do the stools look like? Large, pale, frothy and very foul-smelling stools are highly suggestive of steatorrhea. Characteristically white, fatty stools with plenty of undigested material are most often a feature of giardiasis.
9. Was the persistent diarrhea preceded by an attack of acute gastroenteritis? The situation is highly indicative of secondary lactose intolerance. This condition is fairly common and the stools in it are watery, profuse, accompanied by excess of flatus and have extremely foul smell. The perianal area appears raw and red in a great majority of these children.

II. *Stool microscopy:* Microscopic examination of stools for evidence of parasitic infestations is of definite value. At least three meticulous stool examinations on successive days are essential before one rules out the presence of intestinal infestation.

The presence of numerous large fat globules, after staining with Sudan-3 or eosin, is indicative of steatorrhea. However, this is a rough screening test.

III. *Daily stool fat:* Chemical examination of stools for fat content is the next important investigation.

The child is placed on a diet that provides at least 50 g of fat per day over a period of six days. During the last three days all the stools passed by the child are collected and analyzed chemically. The 24-hour fat excretion is calculated. The mean fat excretion in normal Indian infants and children is 2.32 ± 0.73 g. A fat excretion of more than 5 g/24 hours is

regarded as indicative of steatorrhea. Stool fat can also be measured by a semiquantitative simple, cheap and accurate method, *steatocrit*. It is a method of microcentrifugation of fecal homogenate.

IV. *D-xylose test*: In older children, D-xylose excretion in a 5-hour urine sample, after administration of the pentose in a dose of 1.0 g/kg of body weight, dissolved in water, is estimated. An excretion of less than 20% indicates malabsorption. Infants and young children present difficulties in collection of urine. D-xylose tolerance test is, therefore, preferred in their case. Here, D-xylose is administered in the same dose and blood samples are taken at 0, 30, 60, 90 and 120 minutes by finger prick. Estimation of the pentose in these small samples is done by a micromethod. The peak level of less than 30 mg% is considered indicative of absorptive defect of the small bowel.

A child with steatorrhea but normal D-xylose test is said to be suffering from steatorrhea of nonnitrogenous origin as is the case with cystic fibrosis and, in our experience, with giardiasis also.

V. *Peroral jejunal biopsy*: In view of the nonspecific results obtained from this investigation, its use may be reserved for difficult cases. Only in a few conditions like intestinal lymphangiectasia, abetalipoproteinemia, amyloidosis and intestinal lymphoma is the interstitial histology pathognomonic. In celiac disease, endemic tropical sprue, PEM, iron deficiency anemia and ancylostomiasis, similar types of villous atrophy occur and differentiation on the basis of histologic changes is nearly impossible (Table 24.18, Figs 24.7 to 24.10).

Table 24.18: Usefulness of jejunal biopsy in evaluation of chronic diarrhea/malabsorption

Pathognomonic

- Intestinal lymphangiectasia
- Abetalipoproteinemia
- Amyloidosis
- Intestinal lymphoma
- Giardiasis (sometime)

Nonspecific

- Celiac disease
- Endemic tropical sprue
- Iron deficiency
- Ancylostomiasis

Peroral jejunal biopsy (multiple specimens) may be carried out with the aid of an endoscope.

VI. *Radiology*: Barium meal examination, using a non-flocculable medium may reveal abnormalities like intestinal dilatation, flocculation, segmentation and atypical mucosal pattern. These are indicative of malabsorption but fail to differentiate one condition from another, especially the ones that are responsible for most of the tropical malabsorption in infants and children. This investigation is of value in detecting anatomic defects.

VII. *Other investigations*: **Schilling test, sweat chloride estimation, tryptic activity, lactose tolerance test, etc.** may be performed under



Fig. 24.7

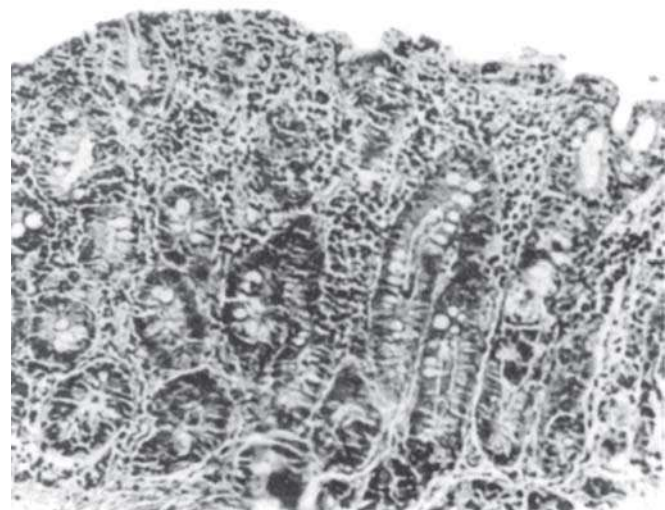

Fig. 24.8

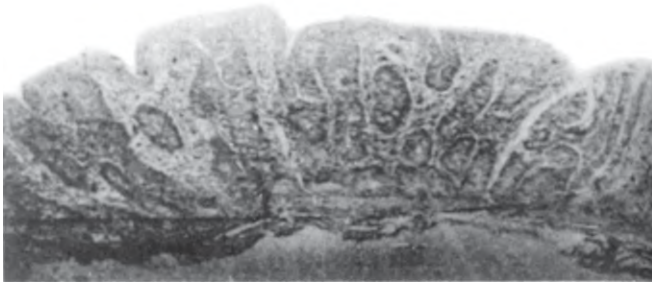

Fig. 24.9

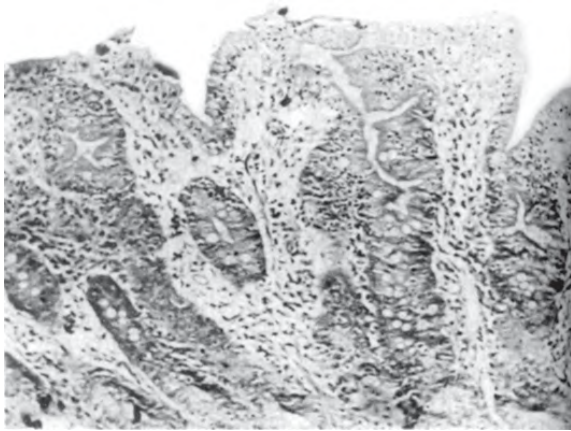

Fig. 24.10

Figs 24.7 to 24.10: Peroral jejunal biopsies showing significant villous atrophy in children suffering from celiac disease, PEM, iron-deficiency and hookworm infestation

special circumstances, depending on the individual merits of a case. These, like jejunal biopsy and radiology, need not be done in every child suffering from chronic diarrhea/malabsorption.

Despite the fact that the list of causes responsible for malabsorption is rapidly expanding, in practice only a few of the conditions appear to monopolize the situation. In our experience, stool fat signifying mild to moderate steatorrhea is usually indicative of PEM, iron-deficiency anemia or intestinal parasitic infestation. Gross steatorrhea is generally due to cystic fibrosis, celiac disease or tropical sprue.

The diagnosis of cystic fibrosis is best confirmed by sweat chloride estimation (sweat chloride is very high in this condition, always above 60 mEq/L) and tryptic activity.

A patient with gross steatorrhea, in whom the diagnosis of cystic fibrosis has been excluded, may be put on gluten-free diet. If he shows amelioration of symptoms, this regimen is continued and absorptive tests (and jejunal biopsy, if done earlier) are repeated after a period of 10 to 12 weeks. If found normal, the patient is challenged with gluten to see if the intestinal abnormality returns. This is now considered adequate to confirm the diagnosis of celiac disease.

If, on the other hand, 3 months of gluten-free diet fails to benefit, the patient's record is reviewed to find, if he could be a case of tropical sprue. A Schilling test is indicated in this situation. If it is abnormal, he should be put on folic acid and/or tetracycline therapy.

Symptomatic control of diarrhea, as the diagnostic tests are in progress, is desirable.

Lastly, it is worthwhile to have a clear idea about the pattern of chronic diarrhea/malabsorption in a particular region. This, together with an individualized approach and an adequate follow-up, solves a vast majority of the diagnostic problems (Fig. 24.11 to 24.14).

Flow chart 24.2 presents algorithmic approach to management of chronic diarrhea in pediatric practice.

CELIAC DISEASE

It is one of the most common causes of malabsorption in the West. Until recently, it was believed to be practically nonexistent in the oriental population. Since 1960s, several Indian adults as well as children suffering from this disorder have, however, been reported.

Etiopathogenesis

It is an abnormal response to the *gliadin* fraction of *gluten* present in wheat, barley, rye and oat. Varying degree of villous atrophy, resulting in absorptive defect, is an essential pathologic lesion. Without dietary manipulation, the small intestinal mucosal damage is permanent. Elimination of gluten from diet, however, leads to disappearance of the changes. Reintroduction of gluten causes their reappearance. This characteristic feature of celiac disease has earned it such descriptive names as *gluten-sensitivity* and *gluten-induced enteropathy*. The so-called *transient gluten sensitivity* that has been reported in several disorders is, therefore, strictly speaking, not to be included under this heading.

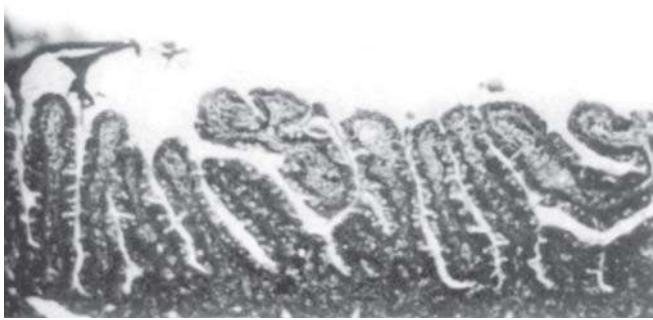

Fig. 24.11



Fig. 24.13

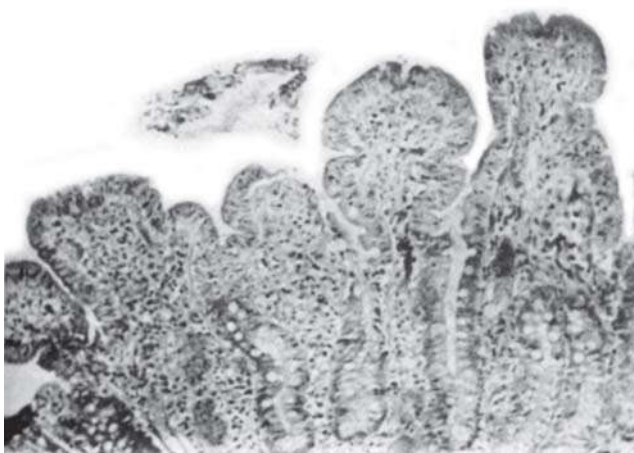

Fig. 24.12



Fig. 24.14

Figs 24.11 to 24.14: Peroral jejunal biopsies from the patients in Figures 24.7 to 24.10 after treatment. Note that the appearances are comparable to the normal as shown in Figure 24.15

Clinical Features

The disorder generally manifests a few months after the introduction of gluten-containing foods—often a wheat preparation in the feeding program. Chronic diarrhea—with large, pale, highly foul-smelling stools which stick to the pangsrowth failure, anemia and other vitamin and nutritional deficiencies, abdominal distention, irritability and anorexia are the usual presenting features (Fig. 24.16).

Diagnosis

In the presence of above mentioned clinical profile, the diagnosis of celiac disease must be seriously considered.

To establish existence of malabsorption, *daily stool fat excretion* should be biochemically determined. D-xylose test is another useful diagnostic tool. Histologic abnormality of the small intestinal mucosa can be demonstrated by *peroral jejunal biopsy*. Responses to removal of gluten from diet and, latter, to gluten challenge are needed to establish the diagnosis.

Serum IgA (rather than IgG) antigliadin antibodies (AGA) represent a reliable, non-invasive and powerful screening test for celiac disease.

Table 24.19 lists the diagnostic criteria for celiac disease as per the European Society of Pediatric Gastro-enterology and Nutrition (ESPGAN).

Flow chart 24.2: Algorithmic approach to pediatric chronic diarrhea

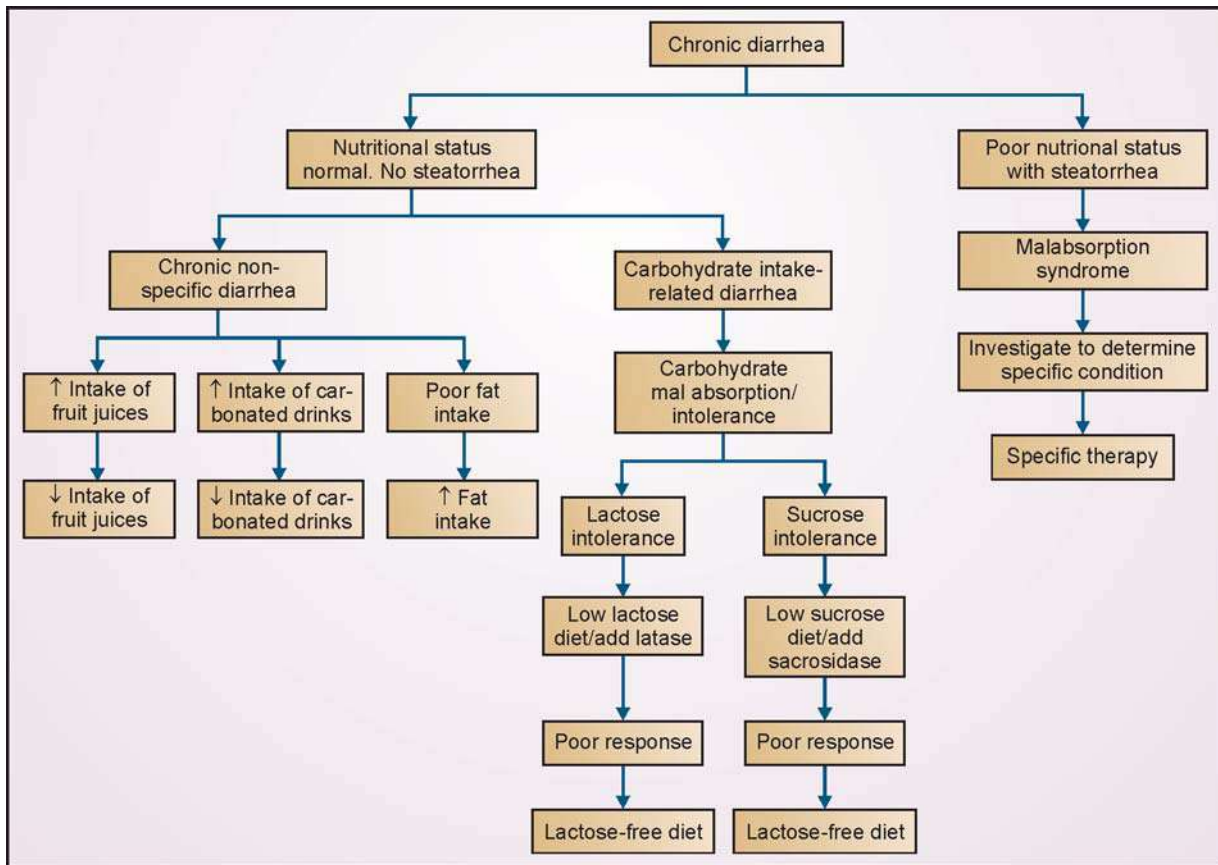

Table 24.19: ESPGAN standard criteria for diagnosis of celiac disease in children

- Abnormal small intestinal mucosa, usually flat
- Clinical response to gluten-free diet
- Histologic response to gluten-free diet
- Histologic plus clinical relapse following gluten-challenge

Coexistence of celiac disease with cystic fibrosis is known. Such a situation causes difficulties in arriving at the exact diagnosis.

Treatment

Besides symptomatic measures, the cornerstone of management is *gluten withdrawal* from diet. The latter has got to be a life-long measure.

CYSTIC FIBROSIS (Mucoviscidosis)

A common disorder in the European countries, its occurrence in India has only recently been recognized.



Fig. 24.15: Peroral jejunal biopsy showing normal histologic appearance

Etiopathogenesis

Cystic fibrosis is a genetic disorder involving the *exocrine glands*—not just the pancreas but the sweat glands as also the glands in the liver as well.

As a rule, intestinal mucosa is normal. Steatorrhea is, therefore, of extraintestinal origin.



Figs 24.16A and B: Celiac disease. Note the growth retardation, abdominal protuberance and irritability in this 5-year-old girl

Clinical Features

Chronic/recurrent diarrhea and recurrent respiratory infections—especially since early infancy—failure to thrive despite exceptionally good appetite and multiple nutritional deficiencies are the common presenting features (Fig. 24.17). Stools are characteristically steatorrheic but may be loose. An obstinate catarrhal cough or “frog in the throat” may be present ever since the first week of life. Abdominal distention, a palpable liver, clubbing, higher incidence of rectal prolapse and nasal polyps, and pseudotumor cerebri are the other findings.

A noteworthy observation by the mother may be “a line of salt on the forehead after sweating” or “the baby tastes salty when kissed”.

At times, cystic fibrosis may manifest at birth as meconium ileus, meconium peritonitis or ileal atresia.

Diagnosis

When clinical picture arouses suspicion, fat balance studies to establish steatorrhea and D-xylose test to establish that steatorrhea is not enterogenous in origin are indicated. Poor tryptic activity lends support to



Fig. 24.17: Cystic fibrosis. This 8-month-old baby had recurrent diarrhea and respiratory infections since birth. His sweat chloride was 256 mEq/L

the clinical diagnosis. But, a high sweat chloride* (in no case less than 60 mEq/L) is a “must” to confirm the diagnosis. Sweat chloride test is considered the gold-standard for diagnosis of CF.

DNA testing for CFT mutations is now available.

Fetal screening of cystic fibrosis (F 508) is not feasible.

Very infrequently, cystic fibrosis may coexist with celiac disease, posing difficulties in arriving at the diagnosis.

Treatment

Every child with proved cystic fibrosis should receive pancreatic enzymes replacement therapy.

PERT effectiveness is enhanced when administered in enteric-coated microspheres form (mixed with acid foodstuff, ‘say sour fruit or fruit juice). Its dose is calculated either by weight of the child or by weight of the fat consumed.

Antibiotics are indicated to control respiratory infections.

Maintenance of nutrition and symptomatic measures are indeed important.

* Sweat chloride may be high (not as much as in CF) in other conditions such as malnutrition, hypothyroidism, hypoparathyroidism, nephrogenic diabetes insipidus, adrenal insufficiency, pancreatitis, G-6-PD deficiency, familial cholestasis, mucopolysaccharidosis, etc.

Gene therapy (DNase), both bovine and human, is now available for cystic fibrosis.

Complications

These include bronchiectasis, systemic amyloidosis, cor pulmonale and cirrhosis. One-half of the CF subjects who reach beyond 20 years, develop CF-related diabetes (CFRD) due to a combination of insulin deficiency and resistance.

ENDEMIC TROPICAL SPRUE

Contrary to the time-honored belief that the condition affects adults only, its occurrence in childhood is being increasingly recognized now.

A typical case is a grown-up child with chronic diarrhea, malabsorption, considerable malnutrition and anemia (Fig. 24.18). Steatorrhea is usually moderate to gross. Partial or subtotal villous atrophy is present. D-xylose test shows poor intestinal absorption. Schilling test is almost always abnormal, indicating that the intestinal mucosal atrophy and absorptive dysfunction are not limited to the upper gut but are present in the ileum too.



Fig. 24.18: Endemic tropical sprue. Note the remarkable growth retardation in this 9-year-old with chronic diarrhea and moderate dimorphic anemia

These patients do not respond to gluten-free diet or to gluten challenge as is remarkable of celiac disease.

Endemic tropical sprue is considered a sort of *folic acid deficiency*. Many patients show encouraging response to 10 to 20 mg/ day of folic acid. A group of patients may need a prolonged course of tetracyclines, favoring an *infective etiology*. Yet, others may have to be given both, folic acid and tetracyclines.

PROTEIN-LOSING ENTEROPATHY

The term refers to excessive loss of plasma proteins (predominantly albumin) into the gut.

Etiology

A number of diseases may have associated protein-losing enteropathy (Table 24.20).

Table 24.20: Etiology of protein-losing enteropathy

Gut

Stomach: Giant hypertrophic gastritis.

Small Gut: Malabsorption syndrome.

Large Gut: Dysentery, ulcerative colitis, Hirschsprung disease.

Cardiac

CCF, ASD, constrictive pericarditis.

Miscellaneous

Immunodeficiency

Clinical Features

Besides the clinical picture of the primary disease, the patient may have poor weight gain, hypoproteinemic edema (with or without chylous ascites), anemia (especially megaloblastic) and vitamin deficiency signs (especially those of fat-soluble vitamins).

Diagnosis

Plasma albumin is usually below 2.5 g/dl. Nutritional, hepatic and renal causes of hypoproteinemia need to be excluded before labeling a case as that of protein-losing enteropathy.

For establishing the diagnosis, measurement of spot stool alpha-1-antitrypsin (unlike albumin it resists digestion) level is of value.

Treatment

Treatment is essentially that of the primary underlying disorder. If there is gross hypoproteinemia from severe losses, albumin infusions may be of temporary benefit.

CARBOHYDRATE MALABSORPTION

It may be of two types: (i) disaccharide malabsorption, and (ii) monosaccharide malabsorption.

Disaccharide malabsorption may be primary or secondary. In *primary disease*, which is very rare, there is congenital deficiency of one or more of the disaccharidase enzymes (lactase, isomaltase, invertase, maltase) in the brush border of the small bowel epithelium. In secondary disease, the enzyme deficiency results from such conditions as acute gastroenteritis, PEM, cow milk protein (CMP) allergy, cystic fibrosis, gluten-induced enteropathy or drugs like neomycin.

Clinical features include watery diarrhea with only little solid matter, acid character of stool, excoriation of the perianal area and buttocks, and abdominal distention and pain. The abdominal cramps are particularly a feature of lactose intolerance in older children and result from excessive gas production.

Diagnosis is from:

- i. Character of diarrhea and circumstances of its onset.
- ii. Low pH of stools (under 6) while the patient is on modest dietary intake of the offending sugar(s).
- iii. Presence of reducing substances in stools.
- iv. Disaccharide (usually lactose) tolerance test.
- v. Breath test involving measurement of H^+ .
- vi. Barium meal: The suspected sugar is added to a barium meal. Defect in its absorption causes fluid retention in intestinal lumen, intestinal hurry and coarsening of the mucosal folds.
- vii. Peroral jejunal biopsy for assay of the enzymes offers the most definitive diagnosis.

In clinical practice, diagnosis is more often confirmed by response to withdrawal of the offending sugar from the diet rather than by cumbersome investigations.

Treatment is by giving low-disaccharide diet. Soya milk* is a good substitute for milk in case of lactose intolerance. As the child grows, symptoms often become less severe in congenital deficiency. In acquired one, the phenomenon is in any case transient and subsides in due course, particularly with the restriction of the sugar.

Monosaccharide malabsorption, though rarely congenital, is being increasingly reported in association with PEM, gastroenteritis, chronic diarrhea, gluten-induced enteropathy, or following surgery.

* Infrequently, allergy to even soya-protein based formula may be encountered

Treatment consists in excluding glucose and galactose from diet. A period of intravenous feeding is usually indicated in serious cases. Reintroduction of the sugars should be cautious.

COW MILK ALLERGY

(Cow Milk Hypersensitivity or Intolerance)

About 1 to 2% of infants may have hypersensitivity to cow milk, manifesting as vomiting, diarrhea (usually watery), colic, rash (infantile eczema or urticaria), rhinitis, otitis media, chronic cough with wheeze (just as in bronchial asthma), anemia and poor weight gain.

Eosinophilia, glucosuria, sucrosuria, lactosuria, aminoaciduria, renal tubular damage, acidosis and pulmonary acidosis may occur in some cases. Smear from rectal mucus shows eosinophils.

Withdrawal of cow milk is followed by disappearance of the manifestations. Its reintroduction leads to reappearance of the symptoms within 48 hours.

Allergy to beta-lactoglobulins appears to be the operative cause in large majority of the cases. Allergy to casein, lactalbumin, bovine serum globulin and bovine serum albumin may also be present. Remember, the disorder is no longer considered a sort of lactose intolerance due to deficiency of lactase in the small intestinal mucosa.

Management consists in omitting cow milk from the feeding regimen. Soya milk or goat milk may well be a good substitute. When the infant approaches the age of 9 month, cow milk may be introduced drop by drop, increasing the amount everyday until the desired intake is reached. Alternatively, if rapid reintroduction is desired, cow milk may be given under the shield of 10 mg of prednisolone daily. Once milk is tolerated, prednisolone should be slowly tapered off to zero dose.

ACRODERMATITIS ENTEROPATHICA

(Brandt Syndrome)

This is a familial disorder with autosomal recessive inheritance and with unique cocktail of clinical manifestations.

Etiology

The cause is zinc deficiency secondary to malabsorption of zinc.

Clinical Features

The condition, manifesting at the time of weaning, is characterized by chronic diarrhea (at times, together with steatorrhea), symmetrical rash or vesicobullous, eczematous, dry, scaly or psoriasiform lesions, paronychia, nail dystrophy, loss of hair (alopecia), stomatitis and glossitis. The skin lesions are most marked over the mucocutaneous junctions (buttocks, around the anus and mouth), face (cheeks) and extremities (knees, elbows). Blepharitis, conjunctivitis and photophobia are the frequent ocular accompaniments. Superadded *Candida albicans* infection may modify the clinical profile. Left untreated, it is accompanied by failure to thrive (FTT).

Differential Diagnosis

Acrodermatitis enteropathica needs to be differentiated from a similar syndrome resulting from long-term TPN (unsupplemented with zinc) and in chronic malabsorption, advanced PEM, cystic fibrosis, maple syrup urine disease, organic aciduria, essential fatty acid deficiency, biotinidase deficiency and methylmalonic acidemia.

Diagnosis

It is by and large clinical. Serum zinc level and alkaline phosphatase activity are reduced. Small intestinal biopsy demonstrates Paneth cell inclusions with parakeratosis and pallor of the upper epidermis.

Treatment

The response to zinc, 1-2 mg/kg/day (elemental) in divided doses is dramatic with improvement in diarrhea and prompt healing of skin lesions. With the availability of zinc for therapeutic use, diiodohydroxyquin which was supposed to yield good results but was likely to cause optic neuritis in infants is no longer employed.

INFLAMMATORY BOWEL DISEASE (IBD)

Three varieties of chronic inflammation of the bowel with overwhelming gastrointestinal presentation and some systemic manifestations are recognized, viz. ulcerative colitis, Crohn's disease (regional ileitis), and intermediate colitis.

Ulcerative Colitis

It is characterized by recurrent bloody diarrhea and inflammation of the colonic mucosa beginning in childhood and adolescence and showing peak age at 15 to 25 years.

Etiology

The disease is now believed to be an immunologically mediated reaction triggered in a genetically vulnerable host. Identical twins, close family members, patients of ankylosing spondylitis and Turner syndrome have greater susceptibility to the disease. Incidence in Jews is 2 to 4 times greater than in general population.

Manifestations

Manifestations include bloody diarrhea with copious mucus, fecal urgency, tenesmus and lower abdominal pain, especially just before defecation, anorexia, weight loss, failure to thrive and nutritional deficiency and growth retardation. Occasionally, the onset may be acute with fulminant bloody diarrhea, high pyrexia and progression to peritonitis and even perforation. Abdominal examination reveals distention and tenderness, especially along the left side. Bowel sounds are exaggerated. Rectal examination may reveal fissures and, at times, fistulae and abscesses.

Extraintestinal manifestations (less frequent in pediatric ulcerative colitis) include arthritis, erythema nodosum, pyoderma gangrenosa, iritis, hepatitis, clubbing, peripheral hypoproteinemic edema, phlebitis, hemolytic anemia, etc.

The disease is characterized by recurrent exacerbations, most subjects remaining asymptomatic and well during remissions that may stretch over months to years.

Diagnostic Investigations

Colonoscopic examination reveals that rectal and distal colonic mucosa is inflamed, granular and very friable. Ulcers are unusual in pediatric ulcerative colitis.

Biopsy reveals an inflammatory lesion with polymorphonuclear infiltration and crypt abscesses.

Barium enema, less sensitive than colonoscopy, reveals diffuse distal lesion that may extend proximally to involve the whole colon only in later stages of disease.

Differential Diagnosis

It is from (i) chronic intestinal infections such as *Campylobacter jejuni*, *Yersinia enterocolitica*, *Edward-siella tarda*, *Aeromonas hydrophilia*, *Plesiomonas shigelloides*, *M. tuberculosis*, *Ent. histolytica*, *Cryptosporidium*, *Isospora belli* and *Cytomegalovirus*, (ii) Crohn's disease, (iii) necrotizing enterocolitis, (iv) intolerance of dietary protein, (v) HUS, (vi) Hirschsprung disease, etc.

Treatment

It is by and large supportive with special attention to the nutrition. Dietary restrictions are of no value. To reduce inflammatory activity, sulfasalazine or 5-aminosalicylic acid (5-ASA), may be employed. Steroids are of value in active disease. New therapeutic modalities like cyclosporine, 6-MP, and azathioprine are of doubtful value.

Surgical resection of the whole colon cures the disease.

Complications

These include perforation of colon, megacolon and colonic cancer (3% risk in first decade and 20% in subsequent years).

Crohn's Disease

Also termed as regional ileitis, granulomatous enterocolitis, it has similar etiology, age incidence, and certain other features as in ulcerative colitis, is characterized by segmental transmural bowel involvement, distal ileum and colon being most commonly affected.

Manifestations

These include crampy abdominal pain and diarrhea that may be accompanied in one half of the patients by pyrexia, malaise, anorexia, growth failure and arthralgia or arthritis. Chronic perianal lesions like skin tags, fissures, fistulas and abscesses even in an asymptomatic child should be considered as early signals of Crohn's disease. Extraintestinal manifestations are more frequent in Crohn's disease than in ulcerative colitis.

Diagnostic Investigations

Barium contrast roentgenograms reveal segmental distribution, irregular mucosa or a cobblestone-like pattern, thickened bowel and enteric fistulae.

Rectal biopsy shows typical granulomas.

Fiberoptic colonoscopy rather than conventional sigmoidoscopy defines the colonic involvement.

Treatment

It is primarily supportive with special emphasis on maintenance of good nutrition and emotional support to the patient and the family. For acute exacerbations, prednisolone needs to be given for 6 weeks and then tapered gradually over 8 to 12 weeks period. In severe exacerbations, it may be given in conjunction with azathioprine. Sulfasalazine, for colonic Crohn's disease, metronidazole for cases with fistulae and severe perianal problems, methotrexate and cyclosporine for some severe cases are also recommended.

Surgical resection is of less value than in ulcerative colitis. The current recommendation is to resect as little as possible (scar removal) for improved results.

Prognosis

Prognosis is rather poor. Though incidence of intestinal cancer is much less than in ulcerative colitis, 1 to 2 decades after the onset of the disease, most subjects with Crohn's disease develop obstructive problems in relation to the intestinal lumen, especially in the ileal disease.

Food Allergic Colitis

A number of food items, the most common being cow milk, egg (white), soy milk, have emerged as potential allergens causing colitis with bloody diarrhea in infants with a history suggestive of atopy.

Supportive investigations include marked eosinophilia, high total and specific IgE, positive skin-prick test, patchy superficial colonic ulceration on colonoscopy and infiltration of lamina propria with eosinophils (many containing IgE) and plasma cells in biopsy.

Elimination of offending food leads to rapid regression of symptoms and a challenge with it causes return of symptoms.

CONSTIPATION

It means passage with difficulty of hard, dry stools once in few days.

Its causes are given in Table 24.21.

Table 24.21: Causes of constipation in various age groups**Neonatal and Infancy**

Benign: Insufficient intake of milk and fluids, artificial feeding, delayed introduction of semisolids and solids, prolonged use of laxatives and purgatives.

Organic: Hirschsprung disease, hypertrophic pyloric stenosis, duodenal atresia, meconium ileus, cretinism, painful defecation as in anal fissure, intestinal parasitosis.

Childhood

Benign: Poor dietetic intake, especially low residue diet, dependency on laxatives and purgatives, poor toilet training, unclean toilet, emotional problems.

Organic: Intestinal parasitosis, anal fissure, intestinal obstruction (subacute).

Treatment is primarily the correction of the underlying cause. It is, therefore, necessary to look for the etiology of constipation in every case.

In general, ensure that child takes good deal of high residue diet and fluids and that the parents encourage him to use the toilet regularly. The use of purgatives should be strongly discouraged. A mild laxative such as liquid paraffin, a rectal suppository or enema may be prescribed after careful consideration. However, make sure that the parents do not indulge in such medication frequently.

VOMITING

Vomiting, a common symptom throughout childhood, is defined as "forcible expulsion of contents of the stomach from the mouth." The strong contraction of the muscles of the abdominal wall is the triggering factor that operates in vomiting, irrespective of the cause.

As is evident from Table 24.22 a wide variety of conditions may be responsible for vomiting.

Remember that treatment of vomiting is primarily of the cause. Every attempt should be made to arrive at the underlying cause through detailed history, clinical examination and, if need be, certain well-planned investigations.

There is a rationale in symptomatically controlling persistent vomiting by stomach wash and/or an antiemetic such as metoclopramide or promethazine, bearing in mind that these drugs can at times cause toxicity. Allowing vomiting to go on and on may cause severe dehydration which, unless controlled with intravenous fluids, can result in serious complication and even death.

Table 24.22: Causes of vomiting in various age groups**Newborn**

Benign: Swallowed air due to erratic feeding, possetting, swallowed amniotic fluid or blood.

Organic: Septicemia or other infections, such as meningitis, intrauterine infections causing encephalitis, otitis, gastroenteritis; congenital obstructive defects of the GIT, birth trauma, birth defects of the CNS, hypoglycemia, galactosemia.

Early Infancy

Benign: Faulty feeding, too much crying, loneliness.

Organic: Infections such as meningitis, encephalitis, URI, whooping cough, gastroenteritis, congenital hypertrophic pyloric stenosis, hiatal hernia, pylorospasm, cow milk allergy, space-occupying lesions, diabetes, uremia, galactosemia.

Late Infancy and Childhood

Benign: Forcing the feed, as an attention-seeking device in upset parent-child relationship, motion sickness, cyclic vomiting.

RECURRENT APHTHOUS STOMATITIS

This most common oral mucosal disease is characterized by periodic painful single or multiple ulcers involving the buccal mucosa (Fig. 24.19). The round and shallow ulcers are surrounded by inflammation that mainly involves the nonkeratinized mucosa. These ulcers heal spontaneously in 1-2 week.

Etiology remains elusive. Occurrence in families is wellknown, suggesting a strong hereditary component. Predisposing factors include poor

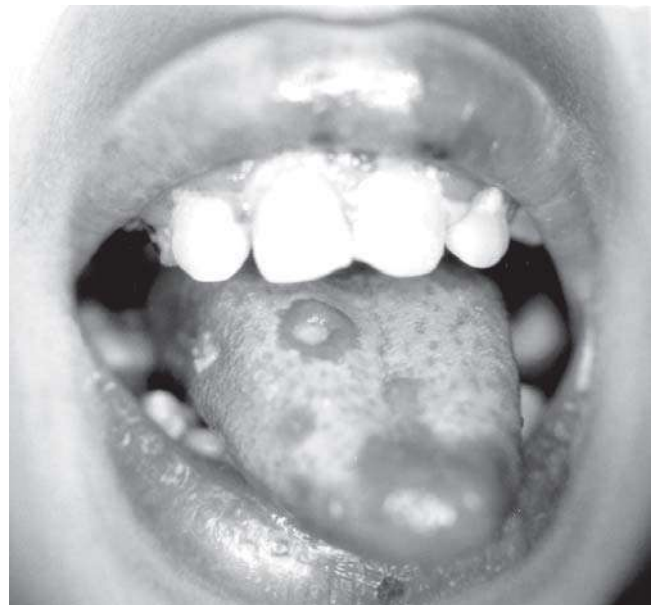
**Fig. 24.19:** Recurrent stomatitis (aphthous)

oro-dental hygiene, nutritional deficiencies, food allergies, stress, hormonal changes, immunologic disorders, and HIV infection.

There is evidence that *Streptococcus* or *H. pylori* may be in its disease process.

Diagnosis is clinical.

Differential diagnosis is mainly from oral herpes simplex. Other conditions that should be considered include recurrent oral ulcers seen in celiac disease, Crohn's disease, SLE and Behcet syndrome.

Treatment is empirical. For relief of pain and inflammation, topical medications (antimicrobial mouthwashes, topical steroids) are the mainstay. Other modalities include antibiotics and immune modulators.

4 THRUSS (*Oral Moniliasis*)

It is a common problem in newborns of mothers suffering from vaginal moniliasis, in the nurseries, in malnourished children and in patients on antibiotic therapy.

Characteristically, the lesions are white elevated curd-like patches which cover lips, tongue, gums and the rest of the oral mucosa (Fig. 24.20). Extension into esophagus may cause *esophagogastritis*. This may result in feeding difficulties and aspiration into the lungs and pneumonia.

Remember that, unlike curd patches, thrush is rather difficult to be removed with a tongue blade and leaves behind an inflammatory base.

Response to local application of 0.5% gentian violet clotrimazole or nystatin 200,000 units/5 ml is usually excellent.

GEOGRAPHIC TONGUE (*Glossitis Acreta Migrans*)

This condition of unknown etiology is characterized by loss of papillae (other than fungiform ones) of the tongue resulting in erythematous areas which are sharply demarcated, irregular, smooth and often raised (Fig. 24.21). Typically, the lesions keep partially regressing or worsening but seldom disappear. At times, the child may complain of local irritation or burning sensation.

No therapy is indicated.

STRESS (SECONDARY) ULCER DISEASE

Stress ulcers are defined as "duodenal or gastric erosions or ulcers occurring as a complication of critical



Fig. 24.20: Oral thrush (*moniliasis*). Note the white elevated curd-like patches. An attempt at removing them leaves behind an inflammatory area. This subject had been on prolonged treatment with antibiotics



Fig. 24.21: Geographic tongue. Note the sharply demarcated irregular and smooth areas. No treatment is indicated

illnesses such as septicemia, hemorrhagic shock, burns, head injury, NSAIDs (aspirin, ibuprofen, nimesulide), steroids, antibiotics (chloramphenicol, penicillins,

tetracyclines, cephalosporins), iron, calcium salts, potassium chloride or other severe physical trauma, etc.” In the first 5 years of life, particularly in newborns, duodenal and gastric ulcers are usually of this nature.

Clinical Features

The condition usually manifests with acute massive painless bleeding on top of the signs and symptoms of the primary disease. Patients with predisposing conditions but on measures that tend to reduce the gastric acidity (say, administration of ranitidine or antacids) are known to have far less incidence of stress ulcers and, if the latter at all occur, the severity is relatively within controllable limits.

Etiopathogenesis

Various pathologic factors include mucosal blood flow, mucus production and cell proliferation. All these factors interfere with host-defense mechanism.

Treatment

Therapy consists in giving large doses of antacids (to maintain gastric pH at or below 3.5) with or without histamine (H_2)-receptor blockers (ranitidine, cimetidine) to counter acidity. The latter is also for hastening the healing of the ulcers. The hydrogen pump inhibitors (omeprazole, lansoprazole) are excellent in treating erosions and ulcers secondary to NSAIDs.

Iced-saline lavage is excellent for stopping bleeding. Additional measures include blood transfusion, correction of coagulation defects and avoidance of acetylsalicylic acid. In the event of severe continuing bleeding, intraarterial infusion of vasopressin (Pitressin) or embolization therapy with gelfoam may be indicated. An occasional case may need suture ligation of the bleeding points together with vagotomy and pyloroplasty.

GASTROESOPHAGEAL REFLUX DISEASE (GERD)

Also termed *chalasia*, the entity is defined as unprovoked passage of gastric contents (mostly acid/pepsin but sometimes even bilious constituents) into the esophagus due to incompetence of the esophageal sphincter.

Manifestations include excessive vomiting, rumination, growth failure, dysphagia and hematemesis.

Nearly all infants become symptomatic by 6 weeks of age though in most symptoms are present right in the first week. By 2 years of age, 60% of the patients become asymptomatic. In the rest, symptoms continue till the age of 4 years or even more.

Aspiration pneumonia risk in infancy is considerable. Those with persistent reflux suffer from recurrent pneumonia. Chronic cough and wheezing are fairly common.

Diagnosis

Clinical impression of GERD can be confirmed by barium swallow (barium esophagogram) done under fluoro-scopy. Presence of a stricture or an associated hiatal hernia (seen as longitudinal gastric folds above the diaphragm) may also be detected at the same time. In cases strongly suspected of GERD but not corroborated by barium esophagogram, repeated studies or prolonged esophageal 24 hours pH monitoring may prove of value (Fig. 24.22). Technetium scintiscan is another valuable diagnostic tool.

An important differential diagnosis is the so-called “eosinophilic esophagitis”, usually secondary to food or environmental allergy. This newly recognized entity should be considered in relapsing or refractory cases of GERD.

Management

Most infants with gastroesophageal reflux respond to careful attention to burping and propping upright during and for one hour after feeding. In those who

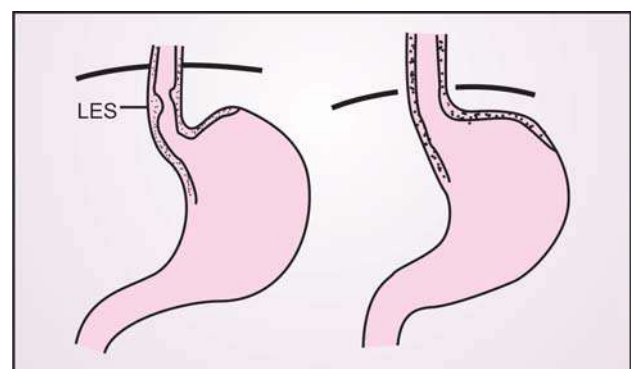

Fig. 24.22: Gastroesophageal reflux. Note the reduced length of intra-abdominal esophagus, poorly defined LES and obtuse angle of His in “B” as compared to “A”. All these anatomic factors favor GER

fail to respond, positional therapy should be extended for 24 hours a day. Recently, it has been advocated that a 30 degree prone position with a slight right lateral tilt is far better than the supine upright position or an infant seat with 30 to 60 degree reclining.

Additional measures include administration of thickened feeds. Concomitant use of antacids or ranitidine for esophagitis, domperidone metoclopramide to accelerate gastric emptying and stimulate muscular activity in the esophagus, and cisapride or omeprazole to enhance gastrointestinal contraction, antroduodenal coordination and LES pressure is recommended. Accelerated weight gain and reduction in vomiting are the earlier signs of favorable response.

Failure to respond to a 6 week course of intensive medical treatment, presence of a stricture and recurrent aspirations and apnea are indications for surgical intervention.

4

GASTROINTESTINAL BLEEDING

Gastrointestinal hemorrhage may present as *hematemesis* or coffee-ground-colored emesis, or blood per rectum which may be fresh (*hematochezia*) or chemically altered black in color (*melenas*).

Etiology

It depends on the age of the patient, on whether bleeding is from upper or lower GIT, on magnitude of bleeding, on associated symptoms and signs, and on general condition of the patient.

A. Upper GIT Bleeding

Newborn period Swallowed maternal blood, hemorrhagic disease of the newborn, necrotizing enterocolitis, stress ulcer of stomach or duodenum, trauma from nasogastric tube, hemorrhagic gastritis, hiatal hernia, esophageal or duodenal atresia, idiopathic.

Infancy and childhood Swallowed blood after epistaxis, tonsillectomy, bleeding from gums, esophageal varices, peptic ulcer, erosive gastritis/esophagitis, reflux esophagitis, sharp foreign body, gastric outlet obstruction (pyloric stenosis), Henoch-Schoenlein purpura, heman-gioma, telangiectasia, tumor, blood dyscrasia.

B. Lower GIT Bleeding

Newborn period Swallowed maternal blood, hemorrhagic disease of the newborn, necrotizing enterocolitis, anal or rectal fissure/ulceration, GIT infection with such organisms as *E. coli*.

Infancy and childhood Anal fissure, swallowed blood from epistaxis, tonsillectomy or dental extraction, varices, stress ulcer, peptic ulcer, polyps, intussusception, dysentery, ulcerative colitis, Crohn's disease, intestinal parasites, Meckel diverticulum, duplication of the gut, Henoch-Schoenlein purpura, hemolytic uremic syn-drome, heman-gioma, telangiectasia, cow milk allergy.

Diagnosis

In doubtful cases of GIT bleeding, it must be confirmed if it is really blood and coming from the GIT. Ingestion of iron or bismuth-containing preparations or eating earth or charcoal (pica) may simulate melena. It is a good practice to confirm the presence of blood chemically.

Secondly, find the amount of blood loss, any previous history of bleeding, any constipation or diarrhea, abdominal or joint pain, epistaxis, surgery on tonsils, etc.

Is the child acutely sick? Is he in shock due to excessive blood loss? How are the vital signs?

Always look for evidence of portal hypertension, hemangioma, purpura, telangiectasia, intestinal obstruction and blood dyscrasia. Nasal passages should be carefully inspected for signs of epistaxis and anus and rectum for fissure, polyps and hemorrhoids. Sigmoidoscopy is necessary in the presence of evidence favoring polyps or colitis.

Investigations include:

- A complete blood count, BT, CT, PT, platelet count, blood group and cross-matching.
- Passage of nasogastric tube into the stomach may reveal if the source of blood is upper GIT. Presence of blood in the gastric aspirate confirms that the bleeding site is proximal to the ligament of Treitz.
- Barium swallow.
- Barium enema is indicated in case of the lower GIT bleeding. Remember to thoroughly clean the bowel in suspected polyp. In intussusception or malrotation with volvulus, such cleaning is contraindicated.

- Diagnostic laparotomy in cases of significant bleeding in whom diagnosis has defied all the investigations.

Management

Management is mainly of the etiologic condition and the blood loss. Massive bleeding, causing shock, irrespective of the etiology, is an indication for intravenous fluids and blood transfusion. Table 24.23 lists the stepwise stabilizing approach.

In upper GI bleeding from mucosal erosion or ulceration, repeated irrigation with tap water or saline plus neutralization or prevention of release of gastric acid through medication (antacid, H₂ receptor antagonists like ranitidine, omeprazole, sucralfate) usually control it.

Management of persistent bleed from esophageal varices is discussed in Chapter 27.

Surgical intervention is indicated in such situations as intussusception, volvulus, Meckel diverticulum or tumors and in ongoing bleeding despite conservative measures in peptic ulcer or stress ulcer disease.

Table 24.23: Stepwise stabilizing approach in gross gastrointestinal bleed

- IV line
- Blood for grouping, cross-matching and other investigations
- Oxygen in case of loss of one-fifth blood volume
- Central venous line for maintaining pressure at 3-8 cm of water
- IV infusion of bolus normal saline or Ringer lactate 10-20 ml/kg speedily
- Whole blood or packed cell transfusion
- Monitor hematocrit (target at 30%) and urine output

Prognosis

The unfavorable prognostic factors include a massive hematemesis, an initial hematocrit of 20 percent, severe anemia with Hb under 7 g percent, infusion of over 85 ml/kg of blood, undetected source of bleed, frank blood or clots in upper GIT and a coexisting liver disease or other systemic disorder and a coagulation abnormality.

RECURRENT ABDOMINAL PAIN (RAP)

Some 5 to 10% of school-going children suffer from RAP. In quite a proportion of them, the etiologic diagnosis remains elusive despite a battery of investigations.

RAP may be classified into two major categories, nonorganic and organic.

Nonorganic RAP may be functional (psychogenic) or secondary to irritable bowel syndrome (IBS), 3-months colic, nonulcer dyspepsia, etc. In case of functional RAP, the pain is periumbilical, nonspecific and inconsistent. There, usually, is a secondary gain pattern (usually skip-ping the school) and the child manages to seek the attention of the parents, nay the whole household. There is often evidence of parental conflict, disturbed interpersonal relationship and parent(s) frequently complaining of abdominal or other bodily pains.

Organic RAP may be secondary to conditions in relation with GIT (gastroesophageal reflux, intestinal parasitosis, chronic constipation, lactose intolerance, food allergy or lactose intolerance, Crohn's disease, ulcerative colitis, *H. pylori* infection, recurrent intussusception, chronic appendicitis, inguinal or abdominal wall hernia), gall bladder (cholelithiasis, choledochal cyst), pancreas (recurrent pancreatitis), genitourinary tract (UTI), urolithiasis, hydronephrosis), CNS (abdominal migraine), hemopoietic system (sickle cell crisis, Henoch-Schoenlein purpura).

In organic RAP, the pain invariably is away from the umbilicus, usually in the dermatome that supplies innervation to the involved viscera. It tends to be constant and consistent, localized or diffuse.

Rebound tenderness may be present. Evidence of the primary disease supports the diagnosis of organic RAP.

A detailed clinical workup is mandatory in the evaluation of the child with RAP.

Initial investigations should be restricted to routine blood, urine and stool (at least on 3 successive days). Further investigations should depend on the clues obtained from the clinical workup and/or initial investigations.

Abdominal ultrasonography is of considerable value in detecting organic RAP secondary to small intestinal pathology or renal disease, and even gastroesophageal reflux (GER).

Upper gastrointestinal endoscopy is important for confirming GER.

Management is dictated by the diagnosis. In a large number of cases, no specific diagnosis may be forthcoming. It is in order to reassure them and carry deworming effective for the common infestations

prevalent in the area. Deworming may well be repeated once in 3 months. In psychogenic RAP, all efforts must be made to alleviate the child's as well as parental tension—sometime, if the need be, with assistance from a psychiatrist.

H. PYLORI INFECTIONS

This spiral-shaped gram-negative bacteria with unipolar flagella was first discovered in 1983 by Barry Marshall and Robin Warren and initially christened *Campylo-bacter pyloridis*. Its characteristics include ability to produce abundant urease and unique fatty acid composition.

Epidemiology

H. pylori infection is truly an infection of children in most of whom it last throughout their life. The development of stomach and duodenal disease depends on certain risk factors which remain to be precisely defined. The incidence is very high in underprivileged communities. Feco-oral route appears to be the major route of acquiring infection with clustering in families and within institutions for mentally retarded and orphanages.

Pathogenesis

The organism is highly host and tissue specific, invading predominantly the mucous layer overlying the gastric epithelium in the antrum and causing gastric inflammation and epithelial changes. The modus operandi of production of inflammation is explained by two hypothesis, termed "leaking roof hypothesis" by Goodwin and "gastrin-link hypothesis"

Clinical Features

Most children with *H. pylori* infection are asymptomatic. In a proportion of cases, chronic gastritis may manifest with recurrent abdominal pain and vomiting. There is a strong evidence of an association between *H. pylori* infection and gastritis (antral) as well as duodenal ulcer disease. Remaining manifestations include refractory iron deficiency anemia (IDA), proteinlosing enteropathy and malabsorption.

Diagnosis

Noninvasive investigations include urea breath test (UBT), preferably employing [13c] -urea (rather than

[14c]-urea) which can be toxic to children because of radioactivity and serology.

Invasive investigations include flexible upper gastro-intes-tinal endoscopy to biopsy the gastric mucosa for histopathology, culture or rapid urease test.

Differential Diagnosis

Gastrospirillum hominis, an organism resembling *H. pylori*, though longer than it, also causes chronic gastritis. It is cockscrew-shaped and is found at neck of pyloric glands in gastric pits.

Treatment

Unlike in adults where "triple therapy" (chosen out of bismuth salt, moxycillin/ampicillin/tetracycline, metronidazole/tinadazole, omeprazole/ ranitidine, clarythromycin) is known to give best results, dual therapy is preferred in children. Best results (100%) are obtained employing a combination of amoxicillin and bismuth subsalicylate. A combination of amoxicillin and tinidazole too gives very good results (94%). In view of the likelihood of salicylism through use of bismuth subsalicylate in children under 10 years, this agent should be avoided in this age group. Instead, colloidal bismuth subcitrate may be used. The known toxicity of bismuth (encephalopathy, ARF) in adults is rare in childhood. If "dual therapy" fails, pediatric *H. pylori* infection may be treated with "triple therapy".

FOOD ALLERGY

The term denotes a group of disorders (both IgE and non-IgE-mediated) in which manifestations follow immunologic responses to specific food antigens. The incidence is around 6 percent in first 3 years of life.

Since *H. pylori* infection is likely to be present at an early age (say 3 months), the target for intervention is probably early infancy.

Causative Foods

The most common cause of food allergy in early infancy is cow milk or soy protein allergy followed by allergy to peanut or egg (white) either through the mother's diet or through direct feeding. In later infancy, and childhood, wheat emerges as the most important food allergy.

Common offending coloring additives used in foods and additives are tartrazine, sunset yellow,

cermoisine and amaranth. These additives may cause hyperactive behavior over and above atopy.

Operational Mechanisms

The possible mechanisms of such adverse reactions to foods include:

1. *Immunologic* IgE-mediated either toxic complex (alpha-gliadin) or cell (lymphocyte)-mediated injury;
2. *Biochemical* Enzyme deficiency (lactase, etc.), nitrite sensitivity (hog dog headache), tyramine headache, toxic effect (alpha-gliadin);
3. Reaction to color and flavoring additives.

A number of adverse reaction to whole cow milk (WCM) ingestion may occur, e.g.

- Occult fecal blood loss with resultant anemia.
- Enteropathy with loss of protein and blood.
- Vomiting and diarrhea.
- Heiner syndrome characterized by pulmonary hemosiderosis, chronic rhinitis, recurrent otitis media, gastrointestinal symptoms and growth failure.
- Recurrent pulmonary infiltrates in X-ray.
- Multiple precipitating antibodies.
- Disaccharide intolerance.

Clinical Features

IgE-mediated food allergy causing rapid development of symptoms, may manifest in the form of GIT symptoms (itching, tingling or angioedema of lips, tongue, throat and palate, vomiting, diarrhea, crampy abdominal pain) or non-GIT symptoms (rhinitis, conjunctivitis, urticaria, angioedema, atopic dermatitis, asthma, anaphylaxis, etc.).

Non-IgE-mediated food allergy causing symptoms over hours to days, manifests as allergic proctocolitis, enterocolitis, enteropathy, allergic eosinophilic, gastroenteritis and dermatitis herpetiformis associated with celiac disease and pulmonary hemosiderosis (Heiner disease).

Combined IgE-mediated and non-IgE-mediated reactions can too occur.

Association between food allergy and behavioral manifestations remains speculative and needs further elucidation.

Diagnosis

Diagnosis is usually by critical testing of the offending food by elimination and provocation (challenge) method, the so-called *double-blind placebo-controlled food challenge* (DBPCFC) which is the gold-standard. Emotional bias of the parents and the child must not be allowed to operate while conducting the tests.

Skin and RAST assay may be employed to identify presence of IgE antibody to food.

Provocative/neutralizing methods of diagnosing allergy by intradermal injection or sublingual administration should no longer be encouraged.

The so-called *eosinophilic gastroenteritis* is diagnosed by demonstrating the number of eosinophils in small intestinal or gastric biopsy.

Treatment

For an acute severe life-threatening IgE-mediated reaction, injectable epinephrine and/or hydrocortisone may be needed.

Treatment is directed at elimination of the offending food. With passage of time, it becomes possible to cautiously reintroduce the offending food into the diet as such or under cover of cromolyn sodium 60 to 200 mg (O) 30 minutes before giving the food.

Bezoars

The term denotes a group of conditions in which there is a collection of exogenous matter in the stomach or intestine. The incidence is highest in females in second decade of life, especially with disturbed personality. Accumulation of hair is referred to as *trichobezoars*, plants and animal material as *phytobezoars*, calcium or casein content as *lactobezoars*. Manifestations are of gastric outlet or partial intestinal obstruction, severe halitosis, secondary iron-deficiency anemia (IDA), hypoproteinemia and steatorrhea. Also see Chapter 6.

TRACHEOESOPHAGEAL FISTULA

Refer Chapter 40 (Pediatric Surgery).

HYPERTROPHIC PYLORIC STENOSIS

Refer Chapter 40 (Pediatric Surgery).

INTUSSUSCEPTION

Refer Chapter 40 (Pediatric Surgery).

ANORECTAL MALFORMATIONS

Refer Chapter 40 (Pediatric Surgery).

HIATAL HERNIA

Refer Chapter 40 (Pediatric Surgery).

INGUINAL HERNIA

Refer Chapter 40 (Pediatric Surgery).

UMBILICAL HERNIA

Refer Chapter 40 (Pediatric Surgery).

4 FURTHER READING

Articles/Chapters

1. Bhatnagar S, Lodha R, Choudhury P, et al. Recommendations: IAP guidelines 2006 on management of acute diarrhea. *Indian Pediatr* 2006;44:380.
2. Dutta P. Acute diarrhea. In Gupte S (Ed): *Recent Advances in Pediatrics (Special Vol. 6: Gastroenterology, Hepatology and Nutrition)*. New Delhi: Jaypee 2000:180.
3. Ghisan FK. Chronic diarrhea. In Behrman RE, Kliegman RM, Jenson HB (Eds): *Nelson Textbook of Pediatrics*, 16th edn. Philadelphia: WB Saunders, 2000.
4. Horvath K, Gadewar S, Perman JA. Gastroesophageal reflux disease versus eosinophilic esophagitis. In Gupte S (Ed): *Recent Advances in Pediatrics-14*. New Delhi: Jaypee 2004:76.
5. Mehta MN. Nutrition in diarrheal diseases. *Pediatr Today* 2007;10:201.
6. McCollough M, Sharieff GQ. Abdominal pain in children. *Pediatr Clin North Am* 2006;53:107.
7. Patwari AK. Dietary management of diarrheal diseases. In Gupte S (Ed): *Nutritional, Growth and Development (Special volume of Recent Advances in Pediatrics)*. New Delhi: Jaypee 1997:354.
8. Rohde JE. Miracle then, still a miracle: The modern management of chronic diarrhea. *Indian J Pediatr Gastroenter Hepatol Nutr* 2000:1:9.
9. Tomar BS. Important microbial causes of acute diarrhea in pediatrics. *Indian J Pediatr Gastroenter Hepatol Nutr* 2000;1:6.
10. Ulshen M. Food allergy (food sensitivity). In Behrman RE, Kliegman RM, Jenson HB (Eds): *Nelson Textbook of Pediatrics*, (16th edn). Philadelphia: Saunders, 2000:1158.
11. Walia BNS, Gupte S, Mehta S, Aggrawal KC. Chronic diarrhea in north Indian children. *Indian J Med Res* 1971;59:1448.
12. Yachha SK, Sharma BC. Gastrointestinal endoscopy. In Gupte S (Ed): *Recent Advances in Pediatrics (Special Vol. 6: Gastroenterology, Hepatology and Nutrition)*. New Delhi: Jaypee 2000:60.

Books/Monographs

1. Gupte S, Horvath K. *Pediatric Gastroenterology, Hepatology and Nutrition*. New Delhi: Peepee 2008.
2. Levy J. *A Practical Approach to Pediatric Gastroenterology*. New Delhi: Jaypee 1989.
3. World Health Organization: *Management of the Patient with Diarrhea*. Geneva: WHO Division of Diarrheal and Acute Respiratory Control, 1992

CHAPTER



25

Pediatric Hepatology

Suraj Gupte, RA Anderson

BASICS OF HEPATOBILIARY SYSTEM

Liver, the largest organ of the body, along with gall-bladder and bile ducts, develops from an evagination of the foregut into the mesoderm of septum transversus.

The biliary system consists of biliary canaliculi (which join to form bile ductules), bile ducts and hepatic ducts (which join to form common bile duct at the porta hepatis). The common bile duct along with the main pancreatic duct at the ampulla of Vater. Blood supply is 75% from portal vein and 25% from hepatic artery. Venous drainage is by hepatic veins that drain directly into the inferior vena cava. Hepatic lobules form the basic architecture. In between liver cells (hepatocytes) and sinusoids are spaces containing tissue fluid.

FUNCTIONS OF LIVER

- Synthesis of most of the plasma proteins (albumin, globulin, fibrinogen), transport proteins, coagulation factors (fibrinogen, prothrombin, F V, FVII, FIX, FX, FXIII) and components of the complement system.
- Elimination of nitrogenous waste by amino acid degradation
- Regulation of blood glucose levels by glycogenolysis and gluconeogenesis
- Desaturation of fats
- Fat digestion by bile
- Storage of vitamins A, D, E, K, B₁₂, iron and copper
- Detoxification of drugs, including alcohol
- Inactivation of hormones

MANIFESTATIONS OF LIVER DISEASE

Common symptoms of liver disease include icterus (jaundice), pruritus, abdominal pain, clay-colored stools, dark-colored urine, abdominal distention, fluid retention, nonspecific symptoms in the form of nausea, vomiting and malaise, and neuropsychiatric symptoms such as change in sensorium, confusion, and altered sleep rhythm. Common signs include icterus, hepatomegaly with or without splenomegaly, spider angiomas, palmar erythema, xanthomata, caput medusae, ascites, flapping tremors, and portal hypertension.

In addition, there may be endocrinal abnormalities and renal dysfunction (hepatorenal syndrome).

DIAGNOSTIC WORK-UP FOR SUSPECTED LIVER DISORDER

Clinical Evaluation

As emphasized in Chapter 1, a good history and physical examination together with skillful interpretation of the common symptoms and signs lay the foundation stone for deciding on the various investigations to arrive at the final diagnosis in a suspected child with liver disease.

Investigative Evaluation

Aims of various investigations are:

- Is the child indeed suffering from a liver disorder?
- If he is, then what is the precise diagnosis?
- How severe is it?
- What is the specific treatment and prognosis?

Biochemical tests (liver function tests) include serum bilirubin with conjugated and unconjugated fractions, aminotransferase levels, alkaline phosphatase, prothrombin time and albumin.

Serum bilirubin and its fractions assist in distinguishing between hemolysis and hepatic dysfunction. A significantly high conjugated fraction is a sensitive index of hepatocellular disease or hepatic excretory dysfunction.

Aminotransferase levels are very sensitive indices of hepatocellular damage. Whereas ALT is liver specific, AST is also derived from other organs.

Serum prothrombin and albumin levels are reflective of hepatic synthetic function.

Percutaneous liver biopsy (detailed later in Chapter 43) is of considerable help in:

- Providing exact histologic diagnosis in such diseases as Indian childhood cirrhosis, neonatal cholestasis, chronic active hepatitis, Reye syndrome, intrahepatic cholestasis, congenital hepatic fibrosis or undefined portal hypertension
- Enzyme analysis in inborn errors of metabolism, and
- Analysis of stored material such as iron, copper or specific metabolites.

Hepatic imaging procedures include a plain X-ray of abdomen, barium swallow, ultrasonography, CT scan.

MRI, radionuclide scanning, cholangiography, endoscopic retrograde cholangiopancreatography (ERCP) and selective angiography.

Temptation for redundant demonstration by several procedures must be resisted.

INDIAN CHILDHOOD CIRRHOSIS

Cirrhosis may result from various diseases such as atresia of bile duct, neonatal hepatitis, cystic fibrosis, hepatolenticular degeneration, galactosemia, glycogen storage disease, syphilis or schistosomiasis. In India and West Indies, however, over 90% cirrhosis in pediatric age group is accounted by what are now called the *Indian childhood cirrhosis* and *Jamaican cirrhosis* or *veno-occlusive disease (VOD) of liver*.

Indian childhood cirrhosis (ICC) is a disease peculiar to the Indian infants and children, usually 6 months to 4 years of age. No age is exempt, however. We have infrequently seen ICC in early months of life too. It was first described by Sen in 1887 from Calcutta. Occasionally cases have been seen in

Indonesia, Sri Lanka, Nepal, Pakistan, Burma, Israel, Bangladesh, Afghanistan, Egypt, Western Africa, UK, USA and Canada.

This designation was suggested by Professor D.B. Jelliffe in early 1950s and appears most appropriate. Infantile cirrhosis, infantile biliary cirrhosis, hypertrophic biliary cirrhosis, subacute toxic cirrhosis, etc. are the other names by which this condition has been referred to in the literature. Logically, however, these are misleading and obsolete now.

Epidemiology

- ICC is prevalent all over India.
- The following communities are predominantly affected:
 - South India—Brahmins
 - Central India—Baniyas
 - North India—Baniyas and Jats
 - North Indian Hills—Rajputs
- Rarely, ICC has been encountered in Muslims and Christians as well.
- Males suffer 4 times more than females; the first-born is at greater risk.
- A large majority of the cases belong to low middle-class families (rural).
- Majority of the patients have vegetarian dietetic background.
- A definite family predisposition is the hallmark of ICC. Siblings and twins are frequently affected. Though blood group incompatibilities and chromosomal defects have not been encountered, same workers have found abnormal dermatoglyphics. An increased prevalence of peptic ulcer, asthma, diabetes and migraine in the pedigrees affected by ICC has been observed.

The remarkable decline in ICC incidence appears to be related to declining practice of employing copper/brass utensils for boiling milk.

Etiologic Considerations

Over the decades, such hypotheses as 'nutritional', 'viral', 'hepatotoxic' 'genetic', 'metabolic' and 'autoimmune' have been postulated.

No single factor seems to be the cause of ICC. It is possible that a genetically-prone child suffers from one or more of the superadded factors (viral, toxic, metabolic and/or autoimmune), leading to the overt picture of ICC.

It is now felt by several workers that the many-fold increase in liver copper in ICC may be related to early introduction of feeds contaminated with copper from copper and/or brass utensils. The high hepatic copper may well be due to:

- Increased absorption,
- Reduced excretion in bile,
- Increased amount of metallothionin, an enzyme known for high binding capacity for copper.
- Some unknown metabolic factors.

Detailed analysis of feeding histories of ICC cases has established that the source of copper in them is top milk (started quite early in infancy), boiled or stored in brass vessels.

Pathology

The basic pathologic change is the diffuse liver cell damage by way of degeneration going on to necrosis and replacement fibrosis. In an established case, there is combination of:

- a. Complete disorganization of liver architecture, resulting in the formation of macronodules and micronodules.
- b. Absence of regenerative activity indicated by regenerating nodules which are encircled by bands of fibrous tissue.
- c. Gross pericellular (creeping) fibrosis in the hepatic lobules.
- d. Predominant neutrophilic exudate in lobules.
- e. Intracellular hyaline that is identical to the so-called *Mallory hyaline* seen in the alcoholic cirrhosis of adults. There is no primary disease of intrahepatic biliary system. Fatty change is either absent or as at its minimal.
- f. Gross excess of copper and/or copper associated protein (*orcein*).

Electron microscopy (EM) shows degenerative changes in hepatocytes, scattered fibrosis, electronulcent cytoplasmic areas with loose arrangements or ganelles, indistinct outline of mitochondria, fine fibrillar Mallory hyaline and irregular dense bodies (cuprosomes).

Similar histopathology is seen in a newly-identified disorder, *hepatic copper overload syndrome*, in American children. This form of cirrhosis has a genetic disturbance in copper metabolism as in Wilson disease. However, onset is early and the affected children die before the age of 6 years or so.

Clinical Features

Two modes of presentation are known:

1. Insidious which occurs in a large majority of the cases.
2. Acute which is less common and sometime mimics VOD.
 - I. *Insidious onset* There are three arbitrary stages which tend to merge with each other. Stage I is characterized by enlarged firm liver with sharp leafy border. Stage II is marked by further enlargement of liver, jaundice and portal hypertension (Fig. 25.1). In stage III (terminal stage) manifestations of hepatocellular failure supervene.
 - II. *Acute onset* ICC may occasionally have sudden onset with jaundice, fever, clay-colored stools and hepatomegaly. All this may have rapid downhill course, the child finally dying in hepatic coma. This is called fulminant or malignant hepatitis. Some cases belonging to the category of "acute onset" may become symptomatic for a variable period and then again have reappearance of the manifestations which behave like ICC of insidious onset.



Fig. 25.1: Indian childhood cirrhosis (ICC). The child presented with definite jaundice, hepatosplenomegaly, ascites, edema, anemia and growth failure. Liver biopsy confirmed the clinical impression

Diagnosis

Liver biopsy is the only reliable method of arriving at a foolproof diagnosis. However, it may not be feasible in an advanced ICC when prothrombin time is prolonged. In such a situation, *cupriuresis* test may be employed. In this test, following oral administration of d-penicillamine, a two-fold hike in urinary copper has a sensitivity of 86% and specificity 60%. Using urinary copper/creatinine ratio as the index parameter, sensitivity of 73% and specificity of 95% with positive and negative values of 83% and 91%, respectively, is obtained (Table 25.1).

Table 25.1: Indian childhood cirrhosis (ICC) vs veno-occlusive disease (VOD)

Factor	ICC	VOD
Onset	Generally insidious	Always acute
Etiology	Not known Copper overload	Hepatotoxic component of bushtea
Presence of veno-occlusive element	Not seen in most cases	Outstanding feature

It has been suggested that hair copper, reflecting the change in liver copper, may be employed as a noninvasive technique for the diagnosis of ICC.

Treatment

Until recently, ICC was dubbed as a “frustrating situation” for which no specific treatment was available. Today, if a diagnosis is made at an early stage (before the development of jaundice or ascites), ICC is potentially treatable.

In the initial stage, an adequate diet with enough of good quality proteins, vitamins and minerals is desirable. Intercurrent infections/infestations should be adequately treated. Administration of corticosteroids, gamma globulins, d-penicillamine or levamisole is advocated by some workers. The best outcome has been obtained in cases treated with d-penicillamine. The drug, administered in a dose of 20 to 40 mg/kg/day for 12 to 18 months, leads to marked improvement and even total reversal in the histopathologic picture.

In the terminal stage when the patient has entered precoma or coma, protein intake should be reduced. Administration of neomycin by gavage and 20% IV glucose drip are helpful. Oxygen may be given as

and when warranted. Exchange transfusion to remove the circulating toxins gives gratifying results in some instances.

In case of portal hypertension causing hematemesis, *Sengstaken tube* may be of help in controlling an esophageal bleed. A portocaval anastomosis may be done to relieve the portal hypertension and complications of hypersplenism.

Prognosis

Despite the best of efforts, ICC invariably had a fatal outcome in the past. Recent claims regarding survival of some cases require to be critically examined.

Prevention (Table 25.2)

Those favoring the etiologic role of copper suggest a trial of excluding use of brass and copper utensils for handling infant foods in the susceptible areas. According to them, “children with ICC always give history of being fed large quantities of top milk boiled or stored in brass utensils since early infancy”. If brass and copper vessels are scrupulously avoided for infant feeding with prolonged breastfeeding and cereal supplementation, ICC should not occur. An aggressive education campaign to switch the rural population from using brass feeding vessels/utensils to aluminium or stainless steel ones is advocated.

Table 25.2: Strategy of preventing ICC through lowering of the copper intake

Source of high dietary copper	Action plan to lower it
• Brass and copper vessels for transportation, storage and boiling of milk	Use of aluminum and steel for tin-coating on brass
• Copper and brass pots for storing drinking water	Change-over to earthenware or steel and aluminium
• Food cooked and stored in brass and copper utensils	Encourage use of aluminium and steel
• Introduction of animal milk before 2 to 3 months of age	Promotion of breast-feeding
• Copper content of drinking water under 0.1 mg/L	Demineralize water
• Foods rich in copper content (liver, nuts, chocolates)	Avoid them or minimize their consumptions

REYE'S SYNDROME

(Including “Reye-like” Diseases)

First described by Reye and coworkers in 1963, Reye syndrome is characterized by encephalopathy and

fatty degeneration of liver and other viscera, especially brain. The “white liver disease” and “encephalopathy with fatty degeneration of the viscera” are its other nomenclatures.

It has been reported from almost all over the world. There are instances of familial occurrence.

The usual age group suffering from the syndrome is 3 months to 18 years. There are occasional reports of its occurrence in neonates and adults. The sex incidence is equal. The syndrome has been reported in twins, siblings and offsprings of first-cousin marriages.

Etiopathogenesis

The exact etiology continues to be unclear. There are instances of its having accompanied glandular fever and chickenpox. Reovirus, influenza B, parainfluenza and ECHO viruses have been isolated from some of the patients. On this basis, virus infection has been suggested as the probable cause.

In North Thailand, it has been associated with a toxin from *Aspergillus flavus*. Some other aflatoxins have also been condemned.

The suggestion that Reye syndrome may be in some way related to the so-called *vomiting sickness of Jamaica* which is known to be caused by hypoglycin from unripe ackee fruit is being investigated.

There are reports hinting at toxins such as isopropyl alcohol, aflatoxin, margosa oil, latex paints, pesticides, pesticide emulsifiers, insect repellants, paracetamol, aspirin and pteridines as the etiologic factors.

The most noteworthy observation is that a strong epidemiologic connection of Reye syndrome with prior administration of aspirin in children suffering from viral illnesses like influenza B or chickenpox stands established.

In nutshell, Reye syndrome appears to be a stereotyped reversible reaction in mitochondria arising from an interaction of viral, toxic and host-genetic factors.

The pathologic features of the disease are well defined. Cerebral edema (without cellular infiltration or demyelination) brainstem herniation and enlarged fatty liver (panlobular microvesicular fat accumulation) without any necrosis are invariably present. Anoxic neuronal degeneration may or may not be present. Identical changes are found in the kidney minus glomeruli, blood vessels and interstitial tissue.

Distinctive pathologic features (seen only on electron microscopy) include enlarged pleomorphic mitochondria with fragmented cristae and flocculation of intramitochondrial protein. Markedly reduced activity of all mitochondrial enzymes in first 26 days of disease may be demonstrated.

CNS manifestations appear to be secondary to metabolic effects of hepatic dysfunction rather than primary CNS infection. Hypoglycemia, hyperammonemia and increased levels of fatty acids—acting singly or in combination—may be important contributory factors. It has been suggested that inhibition of fatty acid oxidation in the endothelial cerebral edema underlies the development of cerebral edema. Defective oxidative phosphorylation within the cells may interfere with the transport of glucose from blood to brain.

Clinical Features

The syndrome manifests 3 to 4 days after the onset of a mild prodromal viral illness like URI, exanthemata (say chickenpox) or diarrhea.

In a typical case, there is a sudden onset of profound disturbances of sensorium (to the extent of coma), vomiting and convulsions. There are no focal neurologic signs of meningeal irritation. Hypoglycemia, hepatomegaly and hepatic dysfunction are the other prominent manifestations. Jaundice is, as a rule, conspicuous by its absence. Electrolyte imbalance or bleeding diathesis may accompany.

Clinical spectrum ranges from relatively mild to rapidly fatal. Mild cases may be missed without liver biopsy (Box 25.1 and Table 25.3).

Box 25.1: Staging of Reye's syndrome

Stage 0 — Alert, abnormal history and laboratory findings conversant with Reye syndrome, no clinical manifestations

Stage 1 — Vomiting, sleepiness, and lethargy

Stage 2 — Restlessness, irritability, combativeness, disorientation, delirium, tachycardia, hyperventilation, dilated pupils with sluggish response, hyperreflexia, positive Babinski sign, and appropriate response to noxious stimuli

Stage 3 — Obtunded, comatose, decorticate rigidity, and inappropriate response to noxious stimuli

Stage 4 — Deep coma, decerebrate rigidity, fixed and dilated pupils, loss of oculovestibular reflexes, and dysconjugate gaze with caloric stimulation

Stage 5 — Seizures, flaccid paralysis, absent deep tendon reflexes (DTRs), no pupillary response, and respiratory arrest

Stage 6 — Patients who cannot be classified because they have been treated with curare or other medication that alters level of consciousness

Laboratory Diagnosis

Blood and CSF sugar are usually low. While SGOT, SGPT and LDH are significantly elevated, serum bilirubin and alkaline phosphatase are either normal or only slightly raised. Prothrombin time is prolonged. Blood ammonia is elevated in most and urea nitrogen in few cases. Metabolic acidosis and respiratory alkalosis may coexist in the same patient.

Liver biopsy shows diffuse microvesicular steatosis with absence of glycogen and slightest inflammatory changes.

EEG changes consist predominantly of slow wave activity.

Treatment

Since the etiology is at best speculative, treatment is simply empirical.

Restoration of blood glucose level, correction of electrolyte imbalance and control of seizures should be achieved. Cerebral edema may be minimized with mannitol infusion and/or corticosteroids.

Exchange transfusion and peritoneal dialysis may prove of value in correcting metabolic defects, such as elevated blood ammonia level as well as blood dyscrasias, if present.

A diet low in proteins with sufficient carbohydrates reduces exogenous protein catabolism. Neomycin by nasogastric tube and enema—as used in hepatic coma—is also a useful measure.

L-carnitine, if used at an early stage, may be of value in safeguarding from progression of clinical Reye syndrome or Reye-like syndrome.

In desperate situations, surgical decompression of RIP may be warranted as a life-saving resort.

Prognosis

A large majority of the children suffering from Reye syndrome die while in deep coma, often within first 24 hours of the onset of neurologic manifestations. Overall mortality may be as high as 85%. Recently, low death rate (20 to 30%) has been reported. Most patients die of CNS complications.

Factors that indicate poor prognosis early in the course of the disease are listed in Table 25.4.

4

In an infant, Reye syndrome may present with dyspnea, hyperventilation, convulsions, apnea, hepatomegaly and features of hypoglycemia. Death rate is much more than in older children. Survivors show greater incidence of neurologic sequelae.

Complications

These include pneumonitis, respiratory failure, cerebral problems, cardiac arrhythmias and diabetes insipidus.

Differential Diagnosis

Clinical picture simulating Reye syndrome may be encountered in:

- CNS infections or intoxications encephalitis, meningitis, toxic encephalopathy
- Hemorrhagic shock with encephalopathy
- Toxins: Hypoglycin A, valproate
- Drug ingestion, e.g. salicylate, valproate
- Metabolic diseases: fructosemia, systemic or hepatic carnitine deficiency, organic acidurias.

Table 25.3: Grading of Reye syndrome on hospitalization

Grade 1: Quiet, lethargic and sleepy, vomiting, LFT abnormal.

Grade 2: Very lethargic, confused and delirious; hyperventilation; hyperreflexia.

Grade 3: Comatose (light) with or without convulsions; decorticate rigidity; pupillary light reaction intact.

Grade 4: Deepening coma, convulsions, decerebrate rigidity, oculocephalic reflexes lost, pupils fixed.

Grade 5: Deep coma, deep tendon reflexes lost, respiratory arrest, pupils fixed and dilated, intermittent flaccidity or decerebrate rigidity; isoelectric EEG.

Table 25.4: Indices of poor prognosis in Reye syndrome**Grade 1 encephalopathy**

- Blood ammonia over twice the upper limit of normal.
- Prothrombin time over 3 seconds

Grade 2 to 4 encephalopathy

- Age under 1 year
- Rapid progression of symptoms to Grade 4 encephalopathy
- Ammonia over 6 times the normal
- Creatine phosphokinase over 10 times the normal
- SGOT/SGPT ratio less than 1
- EEG showing marked slowing
- Nonesterified fatty acids greater than 71 mEq/L
- Marked elevation in long-chain dicarboxylic acids

The survivors generally recover completely though the possibility of such sequelae as mental retardation, epilepsy, hydrocephalus, behavioral problems, spasticity and hemiplegia should be borne in mind. Recurrences have also been recorded though only infrequently.

VIRAL HEPATITIS

Today, viral hepatitis (primary) is considered to be caused by at least 5 specific viruses:

1. Hepatitis A virus (HAV)
2. Hepatitis B virus (HBV)
3. Hepatitis C virus (HCV)
(new name for post-transfusion non-A, non-B virus)
4. Hepatitis D virus (HDV)
5. Hepatitis E virus (HEV) (new name for eternal non-A, non-B virus)
6. *Newer hepatitis viruses*, whose exact role in human disease is yet to be fully ascertained, are:
 - Hepatitis F virus
 - Hepatitis G virus
 - GB agent (GB virus A, GB virus B)

In addition, a number of other viruses (CMV, EBV), bacteria (syphilis, leptospirosis, septicemia), drugs (INH, erythromycin estolate, paracetamol, chlorpromazine) and diseases (alpha-1-antitrypsin deficiency, Wilson disease, galactosemia, CCF, VOD, anoxia, shock, infarction) produce a hepatitis-like syndrome.

Etiologic Viruses

Hepatitis A virus (HAV) is an RNA virus which is very much identical to enteroviruses. It measures 27 nm and produces raised titer of anti-HAV IgM antibody in the serum which is important for its serologic

diagnosis as also anti-HAV IgG antibody which persists virtually for ever, thereby preventing reinfection. Chronic infection never occurs.

Hepatitis B virus (HBV, Dane particle) is a DNA virus, measuring 42 nm with complex structure consisting of surface antigen (HBsAg), a central or core antigen (HBcAg), and DNA polymerase (Fig. 25.2). Another antigen, HBHAg, appears to be a part of HBcAg. Its presence in serum points to highly contagious stage; beyond 6 months to a chronic infection.

Hepatitis C virus (HCV) is an RNA virus, measuring 60 to 70 nm. It was formerly designated post-transfusion non-A, non-B hepatitis virus. Its serum marker is anti-HCV (IgG, IgM).

Delta virus (HDV) is an RNA virus, measuring 36 nm, which is associated with a nucleoprotein (delta antigen) and covered with HBsAg. It needs the HBsAg for its replication and expression. The HDV presence and spread is, therefore, closely linked with HBsAg.

Hepatitis E virus (HEV) is an RNA virus, measuring 32 to 34 nm. It was formerly designated as eternal non-A, non-B hepatitis virus. Its serum marker is anti-HEV.

Mode of Infectivity

In *hepatitis A*, gastrointestinal tract is the possible portal of entry. Occasionally, hepatitis A virus (HAV) can gain entry via blood as well. During the early stages of the disease, virus can be isolated in the blood as well as stools. It continues to pass in stools as long as complete recovery does not occur.

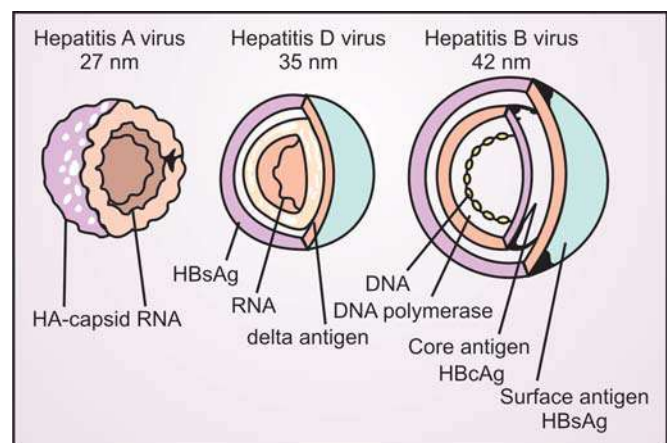

Fig. 25.2: Diagrammatic representation of structures of hepatitis A, B and D viruses

In *hepatitis B*, transmission is almost always via the inapparent parenteral route, e.g. blood transfusion, injection, vaccination, skin or mucosal abrasion, etc. Transplacental passage may effect the fetus, causing neonatal hepatitis. Nonetheless, child-to-child infection, occurring during play or bed-sharing via skin lesions like impetigo, scabies, cuts and infected insect bites, is the major cause of hepatitis in childhood.

In *hepatitis C*, mode of transmission is parenteral, transfusion, or vertical (sexual).

In *delta hepatitis*, transmission is virtually on the same lines as in serum hepatitis. However, vertical transmission from mother to the infant is infrequent.

In *hepatitis E*, mode of transmission is enteral, usually water-borne.

4 Clinical Features

Incubation period of *hepatitis A* varies from 28 to 42 days. In case of *hepatitis B*, it is much longer, i.e. 60 to 150 days. For *hepatitis C*, it is 30 to 60 days, for *hepatitis D* 60 to 80 days (similar to HBV), and for hepatitis E 25 to 60 days.

The disease has a relatively milder course in pediatric age group. The *hepatitis A* onset may be insidious or acute with fever, anorexia, malaise, nausea, vomiting, headache, upper abdominal pain with some hepatomegaly, constipation and, at times, diarrhea, and high colored urine. This is followed by appearance of jaundice in 1 to 3 days. Jaundice may not appear at all in some children. But when it appears, other symptoms like fever and anorexia subside.

An outstanding feature of hepatitis B is *extrahepatic manifestations* such as serum sickness, polyarteritis nodosa, glomerulonephritis (membranous/membrano-proliferative), essential mixed cryoglobulinemia, pericarditis, myocarditis or pleural effusion.

About one-fourth cases have just little jaundice and pain abdomen. A few have rapidly fulminant course with hepatocellular failure and hepatic coma. Those who survive either recover completely or develop chronic hepatitis or postnecrotic cirrhosis later.

Diagnosis

Diagnosis is mainly clinical. The following investigations are of value:

- i. Van den Bergh reaction is direct during early days of jaundice. But, during terminal stage of jaundice, it may be indirect.

- ii. Conjugated serum bilirubin is as high as 10 mg.
- iii. Bromosulfan retention test tends to parallel the retention of bilirubin in blood but remains abnormal for a prolonged period.
- iv. SCOT and SGPT are remarkably high in the early course of the disease; alkaline phosphatase and LDH are only slightly raised.
- v. ESR is increased.
- vi. Electrophoretic analysis shows high gamma globulins.
- vii. Occasionally, monocytosis to the extent of 25% may be present.
- viii. Serologic tests are mandatory for identifying the exact type of viral hepatitis. Diagnosis of HAV depends on demonstration of raised titer of anti-HAV IgM antibody in serum by such methods as RIA or ELISA. For HBV, demonstration of HBsAg is required. It appears quite early in the infection (though during a brief "window period" it may not be detectable) and disappears soon. HDV is diagnosed by demonstration of anti-HDV antibodies of IgM type.

Differential Diagnosis

The differential diagnosis is usually from glandular fever (infectious mononucleosis), leptospirosis, hemolytic jaundice, obstructive jaundice and drug-induced jaundice.

In case of a newborn, diffuse hepatitis of herpes simplex, cytomegalic inclusion disease and toxoplasmosis must also be excluded.

Treatment

For *hepatitis A*

- i. Bed rest (not "absolute"; uncomplicated cases do not need hospitalization) as long as jaundice is present and ESR remains high.
- ii. Small but frequent feeds of high carbohydrate diet; intravenous glucose (10 to 20%) in case of severe vomiting. Fats, in any form, are poorly tolerated and should be avoided.
- iii. Adequate vitamin supplements. Role of vitamins is only supportive. However, vitamin K is of definite value when PTT is prolonged.
- iv. Gamma globulins.

Neomycin may be given in serious cases for sterilization of the gut.

Lactulose, a nonabsorbable disaccharide, should be given as a syrup, 10 to 50 ml/day (O), or its diluted form as retention enema every 6 hours. It lowers blood ammonia level by reducing microbial ammonia production and by trapping ammonia in acidic intestinal contents.

A benzodiazepine antagonist, flumazenil, claims to reverse early hepatic encephalopathy.

Steroids must not be given since they increase risk of chronicity and relapses. Their use just-because they produce temporary sense of well-being and improvement in liver function is injudicious.

Hepatotoxic drugs like chlorpromazine, paracetamol, etc. should be avoided. Phenobarbital, chloral hydrate or diazepam are good enough for sedation.

For *hepatitis B*, no special treatment is required, except in special situations such as fulminant hepatitis and chronic hepatitis which is discussed later.

For *hepatitis C* (chronic), drug therapy with interferon and ribavirin is available.

For *hepatitis E*, interferon and ribavirin may be of value.

Prevention

For *hepatitis A* which is transmitted by feco-oral route, prevention is achieved by improving the food, water and personal hygiene and environmental sanitation.

Passive immunization can be attained by administering gamma globulin rich in anti-HAV antibodies (0.1 ml/kg) or specific anti-HAV gamma globulin (0.05 ml/kg) intramuscularly to close contacts of a case of hepatitis A (as in a family; not school) or to a child moving to an endemic area.

A vaccine (Havrix) for human use is now available. This highly safe and highly immunogenic vaccine (formaline-killed) has emerged as a major step in the prophylaxis of hepatitis A. A live attenuated hepatitis A vaccine too is now available. Also see Chapter 10.

For *hepatitis B* which is transmitted via a parenteral route, prevention is achieved by avoiding contamination by infected blood or its products. Screening of blood donors is essential. Utmost care needs to be exercised while handling HBsAg-positive material.

Passive immunization can be achieved by administering specific anti-HBs gamma globulins for short-term immediate protection in such situations as accidental needleprick, neonate of a HBsAg-positive mother, etc.

Hepatitis B vaccine (Engerix-B, Shanvac-B, HBvac, Envac, Hepavax) provides active protection which is long-lasting though not immediate. Its indications are:

- Newborns of mothers who are chronic HBsAg carriers.
- Newborns of mothers who have had acute hepatitis B in the second and third trimester of pregnancy.
- Children having large and repeated transfusions of blood or its derivatives, say hemophiliacs, children with chronic anemias, children with operable cardiomyopathy, and children with portal hypertension at risk of bleeding.
- Children receiving hemodialysis.
- Adolescents with parenteral drug addiction.
- Children in close contact with a chronic HBsAg carrier in the family or institution for the mentally retarded.
- Children awaiting liver transplantation.

In fact, the WHO has now recommended that the hepatitis B vaccine may be incorporated as the seventh vaccine in all national child immunization programs in S-E Asia and Pacific in order to eradicate hepatitis B and much of the liver cancer. This vaccine is the first genetically-engineered cancer immunization. It is a part of the currently recommended immunization schedule of the Indian Academy of Pediatrics (IAP).

The dose is 0.5 ml (IM) for children under 10 years and 1 ml for those over 10 years. There should be a gap of at least 1 month between the first and the second doses and a gap of 6 months before the third dose is given. Also see Chapter 10.

In order to provide immediate and long-lasting protection, it is advisable to combine specific anti-HBs gamma globulins with vaccine.

For *hepatitis C*, prevention consists in limiting the use of potentially dangerous blood derivatives and preheating of antihemophilic factor.

For *delta hepatitis*, preventive measures are on the same lines as for hepatitis B.

For *hepatitis E*, prevention consists in improving the hygienic and sanitary conditions in the same way as for hepatitis A.

Prognosis

Overall prognosis is good. Recovery is complete in 95% of cases. Only a small proportion of the cases

die following development of fulminant hepatitis and hepatic coma. A small percentage may progress to *chronic hepatitis*.

FULMINANT HEPATITIS (Including Subfulminant Hepatitis)

Etiology

The disease occurs due to remarkably high virulence of the virus or high host susceptibility as in patients with immunologic deficiency disease or on immunosuppressant agents. A large majority of cases secondary to hepatitis B virus. Its two leading components, hepatic failure and encephalopathy, develop within two weeks of development of icterus. In case of subfulminant hepatitis, this period may vary from 2-12 weeks.

Clinical Features

Two types of presentations are recognized. *First*: the disease proceeds in a rapidly fulminant course with increasing icterus (Fig. 25.3), ascites, shrinking liver, worsening of laboratory indices and coma. *Second*: the disease begins as benign hepatitis. After apparent improvement, the patient suddenly starts worsening in the second week of the disease, eventually ending up in hepatic coma, sepsis, hemorrhage or cardio-respiratory arrest. Major manifestations are related to cerebral edema, coagulopathy, hypotension, hypoglycemia, renal dysfunction, pancreatitis and infection.



Fig. 25.3: Fulminant hepatitis. Note the severe icterus

Treatment

It is on the same lines as in acute hepatic failure. Combined exchange transfusion and peritoneal dialysis may be employed. Steroids should be avoided; so should diuretics, sedatives and tranquilizers.

Prognosis

Mortality is as high as 60 to 80%.

FULMINANT/ACUTE HEPATIC FAILURE (Hepatic Encephalopathy)

It is defined as a constellation of potentially reversible neuropsychiatric and neurologic manifestations in a subject with advanced hepatic dysfunction.

Etiopathogenesis

Causative factors include infections (HAV, HBV, HCV, HDV, HEV, EBV, CMV, herpesvirus, varicella zoster virus, *Salmonella typhi*), drugs (paracetamol, isoniazid, rifampicin, pyrazinamide, valproate, halothane), metabolic disorders (Wilson disease, ICC, galactosemia, fructose intolerance, neonatal iron overload) and toxins (copper).

Precipitating factors include massive GI bleed, too rapid abdominal tap, CNS depressants (calmpose), hypoxia, hypoglycemia, hypokalemia, septicemia and high protein diet.

Various hypothesis put forward to explain CNS manifestations are:

- *Hyperammonemia*, because of failure of the diseased liver to metabolize it to urea, causes neurotoxicity.
- *Complex interactions* between ammonia, fatty acids and methionine derivatives causes HE.
- *False neurotransmitters* (octopamine) replacing true neurotransmitters (dopamine).
- *Disproportionately high aromatic amino acid (AAA) concentration*. Imbalance of branched chain (leucine, isoleucine and valine) vs aromatic (phenylalanine, tyrosine, tryptophan) amino because of increased uptake of latter in hepatic dysfunction acids mediates CNS depression.
- *GABA-Ergic hypothesis* Failure of liver to detoxify gamma amino butyric acid (GABA) causes CNS manifestations.

Clinical Grading

It is listed in Table 25.5.

Table 25.5: Clinical grading of hepatic encephalopathy

Stages	Symptoms	Signs	EEG changes
1.	Spans of lethargy euphoria; reversal of day-night sleeping; could be alert	Finds difficult to draw figures and perform mental tasks	Normal
2.	Drowsiness/ agitation behavioral problems, wide swings in mood, disorientation	Asterix, incontinence, fetor hepaticus	Generalized slowing, q waves
3.	Stupor but arousable, confused, incoherent speech	Asterix, hyper-reflexia, rigidity, extensor reflexes	Remarkably abnormal triphasic waves
4.	Coma	No asterixis, flaccidity,	Remarkably abnormal bilateral slowing, d waves, electric-cortical silence
4a	Response to noxious stimuli	areflexia	
4b	No response to noxious stimuli		

Investigations

These include LFT, serum ammonia, blood sugar, serum electrolytes, blood gas analysis, infection screening, viral serologic markers. EEG changes include theta waves in stage II and III, delta waves in stage IV and triphasic waves in stage V. Visual-evoked potentials (VEP) has an edge in early detection, monitoring and differential diagnosis of HE. Lumbar puncture is helpful in differential diagnosis. CSF alpha ketoglutarate and glutamine is usually raised in HE.

Management

Measures aimed at reducing the formation of ammonia include 10% dextrose through IV line, elimination of protein from diet until sensorium reverts to normal, bowel washes and 50% mag sulfate enema, sterilization of gut employing oral neomycin or ampicillin, nasogastric aspiration and lactulose (or lactilol), 10-50 ml every 2-4 hourly, until it produced 2-3 stools/day.

Measures aimed at reducing cerebral edema include raising the headend of the bed (with head in neutral position), fluid restriction, IV mannitol bolus infusion (20%; 2.5-5 ml/kg/dose) every 6-8 hourly.

Appropriate chemotherapy for superadded infection(s), including *Candida* and anaerobic infection.

For controlling/preventing coagulopathy and GI bleed, IV vitamin K, fresh frozen plasma, and H₂ blockers (ranitidine), antacids, etc.

For controlling/preventing hypoglycemia, IV dextrose (10%)

For controlling/preventing electrolyte imbalance (hypokalemia, metabolic alkalosis), appropriate monitoring and correction.

For respiratory failure, oxygen and assisted ventilatory support.

For seizures, half of the dose of diazepam as a brief bolus IV infusion.

For hepatorenal failure, restriction of sodium and fluid, and, if the need be, hemodialysis or peritoneal dialysis.

Bioartificial liver support system pending liver transplantation may provide the liver time for regeneration.

For hypotension, dopamine infusion.

For benzodiazepine excess-induced HE, the antagonist, flumazenil, is of value.

Other conservative measures include strict avoidance of sedatives, and administration of branched-chain amino acids (BCAA), bromocriptine, zinc and L. dopa.

Liver transplantation and nonbiologic and biologic methods of hepatic support are of considerable help in improving the prognosis.

Prognosis

With modern intensive care, survival is around 30-50%. With liver transplantation, survival has gone up to 60-70%.

CHRONI LIVER DISEASE (CLD)

The term is employed for a widespectrum of liver disorders with persistent inflammation of liver tissue which, unless treated, are likely to progress to end-stage liver disease in the form of cirrhosis or carcinoma. Tentatively, the disease process should have been present for at least three months. It is estimated that around one-third of hepatobiliary disorders fall under this title. All types of chronic hepatitis come under this category. In fact, the large chunk of CLD is constituted by chronic hepatitis. Remaining conditions include hepatic fibrosis and cirrhosis.

CHRONIC HEPATITIS (CH)

It is defined as continuing inflammation of liver parenchyma for at least 3-6 months. If it fails to resolve with or without treatment, it is likely to progress to an irreversible and severe chronic liver disease that finally terminates as cirrhosis/end-stage liver disease. The presence of continuing hepatic inflammation is confirmed by raised hepatic transaminase levels.

Besides the persistent viral infection (HBV, HBC, HBD, infrequently HBE; never HBA), drugs, metabolic liver injury, autoimmune mechanism or unknown factors may be responsible for its occurrence in a significant proportion of cases. The exact modus operandi of pathogenesis is not known. Demonstration of antinuclear and antismooth muscle antibodies in serum and multisystem involvement in the form of arthropathy, rashes, thyroiditis, and Coombs-positive hemolytic anemia strongly hint at an autoimmune process.

In pediatric practice, leading causes of CH are hepatitis B, hepatitis C, autoimmune hepatitis and metabolic liver disease (Table 25.6).

Table 25.6: Etiology of chronic hepatitis

- Infectious hepatitis B, hepatitis C, hepatitis D
- Autoimmune: Three types
- *Metabolic:* Wilson disease, alpha-1-antitrypsin deficiency, storage disease, galactosemia
- Drugs: INH, ketoconazole, methyl dopa
- GI disorders: IBD, celiac disease, CF
- Hepatobiliary disorders: Biliary atresia
- Miscellaneous: Parasitosis, polycystic disorders
- Cause undetermined

Major Types

Old Classification

Pathologically, CH may be classified into three types:

1. Chronic persistent hepatitis
2. Chronic active hepatitis, and
3. Chronic lobular hepatitis.

Chronic persistent hepatitis (CPH) is unresolved viral hepatitis, characterized by intraportal inflammation. Liver is enlarged but soft. It usually runs a slow and benign course. Despite nonavailability of any specific treatment, prognosis is good. The subjects who become persistent carriers of HBsAg are prone to develop hepatocellular carcinoma (Figs 25.4 and 25.5).



Fig. 25.4: Chronic persistent hepatitis

Chronic active hepatitis (CAH) is an uncommon sequelae, characterized by widespread loss of lobular architecture, portal and periportal inflammation, piecemeal necrosis and active septa. Liver is moderately enlarged and firm. Spleen is usually enlarged. Ascites is present. The disease has rapidly progressive and downhill course. Steroids, D-penicillamine, azathioprine and interferon are generally recommended in its treatment. With this therapy, majority of the patients show significant improvement with prolongation of life though relapse may occur. The possibility of progression to cirrhosis, despite good response to therapy, remains. The patient with end-stage liver disease secondary to autoimmune and HVC forms of chronic active hepatitis (not HVB) may benefit from orthotopic liver transplantation (see Fig. 25.5).

Chronic lobular hepatitis (CLH) is characterized by intraportal and lobular inflammation, hepatic lobule being infiltrated from portal to central areas with central areas of necrosis of hepatocytes. Jaundice is usually present and there is general malaise. The histologic as well as biochemical picture resembles that of acute hepatitis. Response to antiviral therapy or immunosuppressant therapy (depending on the etiologic factor) is reported to be good. Even without treatment, course is frequently benign. Risk of cirrhosis is significant (see Fig. 25.5).

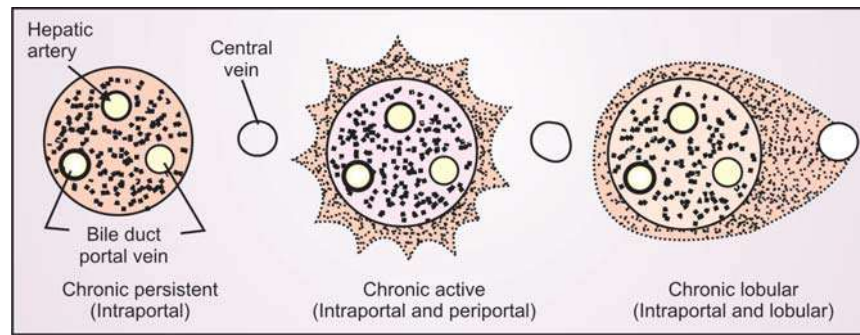

Fig. 25.5: Histologic picture in three forms of chronic hepatitis

New Staging/Grading

Now the trend is to stage and grade chronic hepatitis based on the fibrosis and neuroinflammation respectively, in the liver biopsy (Boxes 25.2 and 25.3).

Box 25.2: Staging of chronic hepatitis based on fibrosis

Stages	Fibrosis	Architecture
Stage 1	None or minimal	No significant enlargement of portal tracts; no septa
Stage 2	Dominantly periportal	Enlarged portal tracts, periportal fibrosis or portal-to-portal septa but no architectural distortion
Stage 3	Septal	Significant septal fibrosis and architectural distortion or certain cirrhosis
Stage 4	Cirrhotic changes	Probable or certain cirrhosis

Box 25.2: Grading of chronic hepatitis based on neuroinflammation

Grades	Portal/periportal necroinflammation	Lobular necroinflammation
Grade 0	None or minimal	None
Grade 1	Portal inflammation	Only inflammation
Grade 2	Mild limiting plate necrosis	Severe focal cell damage
Grade 3	Moderate limiting plate necrosis	Severe focal cell damage
Grade 4	Severe limiting plate necrosis	Bridging necrosis

Clinical Features

Different modes of onset/presentation of CH include:

- *Acute viral hepatitis-like* with prolongation of symp-

toms (Wilson disease, alpha-1-antitrypsin deficiency, autoimmune hepatitis)

- *Chronic insidious type* with portal hypertension
- *Asymptomatic type* The disease is picked up by high index of suspicion when investigating for some other disorder or when liver is found to be unusually firm.

Clinical clues favoring CH include a history of neonatal cholestasis syndrome, chronic liver disease in the family, relapse or persistence of symptoms of acute hepatitis over at least 3 months, a small and shrunken liver with relative enlargement of the left lobe, hard or nodular liver, splenomegaly, edema and/or ascites, upper GI bleed, failure to thrive (FTT), muscle wasting, vitiligo, arthritis, spider nevi, facial telangiectasia and extrahepatic manifestations of autoimmune hepatitis or Wilson disease (Table 25.7).

Diagnosis

Diagnosis is by:

- LFT (serum bilirubin, including direct and indirect, AST, ALT, alkaline phosphatase) to assess status of liver
- Ultrasonography of abdomen, upper GI endoscopy and Tc 99m hepatic scan to assess presence of portal hypertension and cirrhosis
- Liver biopsy for confirmation of pathologic diagnosis.

Investigations required for identifying exact cause include:

- Viral markers
- Autoantibodies
- Alpha-1-antitrypsin
- Copper studies
- Aminoacidogram
- Specific metabolic studies
- TORCH profile for ILI infections.



Table 25.7: Chronic persistent vs chronic active hepatitis

Features	Chronic persistent hepatitis	Chronic active hepatitis
Cause	Usually viral; also drug-induced	Usually viral; also drug-induced, metabolic, autoimmune etc.
Onset	Acute	Insidious
Appearance	Well-looking child	Sick-looking child
Course	Benign	Variable with remissions and exacerbations
LFT	Mild biochemical abnormality	Moderate biochemical abnormality with hypergammaglobulinemia
Liver biopsy		
Site of inflammation	Portal	Periportal intralobular extension
Piecemeal necrosis	Minimal or absent	Classical
Lobular architecture	Preserved	Distorted
Fibrosis	Minimal or absent	Common
Cirrhotic change	Rare	Common
Treatment	Supportive	Specific

Management

Specific therapy is possible in only a minority of the subjects (Table 25.8).

Table 25.8: Specific (definitive) therapy in chronic hepatitis

Condition	Therapy	Other measures
Autoimmune CAH	Steroids, azathioprine	
Wilson disease	Penicillamine	Avoid copper-rich foods, e.g. liver, shellfish, mushroom, chocolates, nuts
Hepatitis B and C	Interferon	
Galactosemia	Galactose-free (milk-free) diet	

Such complications as upper GI bleed, ascites, peritonitis and encephalopathy should be appropriately treated.

Supportive care should be in the form of much higher intake of energy (1.5-2 times the normal requirements), 4 g/kg/day of protein and fat soluble vitamins (5-10 times the normal requirements).

Prognosis

It depends on the type and the treatment offered. Generally speaking, severe chronic active hepatitis,

despite treatment, ends up in end-stage liver disease with cirrhosis or hepatocellular carcinoma.

AUSTRALIA ANTIGEN

The hepatitis-associated antigen was first detected in the serum of an Australian aboriginal. Hence the name Australia antigen.

The virus-like antigen is a spherical particle, 20 nm in diameter. It consists of a core which is found in the liver cells and a double shelled surface antigen in the cytoplasm. The surface antigen called HBsAb is measured in blood. The core antigen is termed HBcAg and its antibody HBcAb. Measurement of anticore-antibodies may be useful in detecting serum hepatitis and monitoring infectivity of any volunteer receiving vaccine or immunoglobulins. In case HBsAb shows a rise, there is immunity and not primary infection. Unfortunately the acute scarcity of the reagents becomes a problem in the routine testing of HBsAb.

Unlike 0.1% carrier state in the west, as high as 20% of the population in tropics may be the carrier of Australia antigen.

Detection of Australia antigen is by radioimmunoassay, gel diffusion, complement-fixation test or reverse passive hemagglutination. Negative result does not rule out hepatitis B.

Australia antigen may be positive in leukemias, Hodgkin disease, mongolism and leprosy, besides the well-known entity, serum hepatitis.

PORTAL HYPERTENSION

Portal hypertension is a frequent problem in practice. It is said to exist when pressure in the portal-venous system (normal variation 5 to 10 mm Hg) exceeds 12 mm Hg.

Two types are known: (i) intrahepatic, and (ii) extrahepatic, existing in the ratio of 40:60 in India.

INTRAHEPATIC PORTAL HYPERTENSION (IHPH)

Etiology

Cirrhosis is undoubtedly its commonest cause. The usual type of cirrhosis in pediatric practice, as discussed earlier, in our country is the so-called *Indian childhood cirrhosis*.

Jamaican veno-occlusive disease causes widespread occlusion of small and medium hepatic veins and early development of portal hypertension. The disease is rare in India.

Budd-Chiari syndrome, involving main hepatic vein from various causes like thrombosis, vasculitis, sepsis or tumor, is rare in childhood.

Portal vein thrombosis is a relatively common cause of portal hypertension. This almost always follows umbilical sepsis and repeated exchange transfusions using the umbilical vein.

Congenital hepatic fibrosis, usually in association with renal anomalies, is a rare cause of portal hypertension.

Clinical Features

Ascites with abdominal distention (usually without *caput medusae* or *varicose veins*), hepatosplenomegaly* (spleen bigger than liver) and pain abdomen are the commonest presenting features. Hematemesis, melena and jaundice are less frequently seen. Thrombocytopenia due to hypersplenism may develop. Application of pressure over liver does not cause distention of the jugular vein, the so-called *hepatojugular reflex*.

Diagnosis

Liver function tests, though abnormal, are not quite helpful in localizing the obstruction.

Upper GI endoscopy, barium swallow, ultrasonography (with Doppler studies) and portal angiography (with CAT scan or MR images) may show esophageal varices.

Hematologic investigations are required to find out what effects repeated hemorrhages have caused and the current hematologic status of the patient.

Liver biopsy is of great help to establish the diagnosis of the underlying disease process.

The most reliable investigation is the splenic *venoportogram* which bares open the whole portal system in the X-rays or ultrasonography so that the site of obstruction can be located.

Treatment

Initial management of variceal bleed consists of crystalloid infusion, vitamin K, nasogastric

intubation, a H₂ receptor antagonist (ranitidine) intravenously.

If the patient is significantly anemic and/or having large hematemesis, blood transfusion is usually needed. To control persistent bleeding from esophageal varices, endoscopic sclerotherapy, intraesophageal balloon catheter, Sengstaken tube, is passed or intravenous vasopressin, somastostatin or a somastostatin analogue (octreotide) administered.

Propranolol therapy has been found to be of value for prevention of recurrent gastrointestinal bleeding. The beneficial effect of this therapy appears to be from reduced portal pressure secondary to decreased cardiac output.

To check distressing ascites, it may become appropriate to give a diuretic like frusemide. Such patients run the risk of going into hyponatremia and hypokalemic alkalosis. Remember to maintain the fluid and electrolyte balance.

The eventual answer is a *bypass operation* to join the portal vein with a systemic vein, provided that cirrhosis has not already developed.

Prognosis

It depends on the underlying cause and the treatment offered.

Without treatment, hepatic failure, coma and death are a rule. Even with treatment, portal hypertension associated with cirrhosis (as a cause or effect) ends in a similar fashion.

Early surgical intervention in hepatic vein thrombosis or Budd-Chiari syndrome (not resulting from malignancy) gives good results.

EXTRAHEPATIC PORTAL HYPERTENSION

Etiology

Its common causes are umbilical sepsis during neonatal period (Fig. 25.6), umbilical vein catheterization and dehydration, leading to splenic or portal vein thrombosis. Other causes include congenital splenic or portal vein anomalies and compression of portal vein by lymph glands and bands.

The obstruction can be anywhere between hilum of the liver to the hilum of the spleen.

* Following a significant "bleed", spleen may temporarily shrink, causing reduction in its size

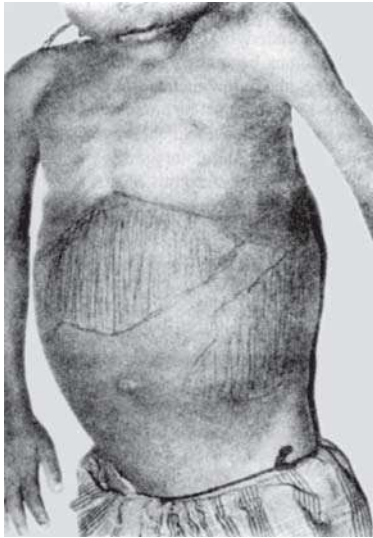

Fig. 25.6: Extrahepatic portal hypertension due to portal vein thrombosis secondary to umbilical sepsis during neonatal period

Treatment

Medical treatment to control the disease has its place. This helps in at least two ways. Firstly, chances of surgical shunts appear to improve as the child gets older. Secondly, he may develop a decompressive shunt so as to prevent hemorrhage from the varices.

The medical measures have already been underscored. Remember to treat anemia with hematinics, to avoid drugs like aspirin and to make sure that the child takes soft food in small amounts but at frequent intervals.

Sclerotherapy, i.e. direct injection of varices, is employed by some in children less than 10 years of age prior to operation or when other measures have failed to control bleeding.

Simultaneous *splenectomy* and *splenorenal shunts* are the most popular surgical procedures but these have their limitations.

If portal vein is spared by the disease process, the most satisfactory procedure would be *portocaval anastomosis*.

NEONATAL CHOLESTASIS SYNDROME (NCS)

By definition, it is a prolonged elevation of serum levels of conjugated bilirubin beyond first 14 days of life. In India, it is estimated to constitute 30% of the hepatobiliary disorders.

Etiology

A large number of conditions may cause neonatal cholestasis (Table 25.9). Experience in India and other countries of S-E Asia indicates that around 67% cases are equally distributed between extrahepatic and intrahepatic etiology. The left over 33% cases are of idiopathic neonatal hepatitis. Two most likely mechanisms are virus-induced hepatic insult and metabolic liver disease. Irrespective of the cause, clinical manifestations of all forms of cholestasis are by and large similar.

Clinical Features

Manifestations of neonatal cholestasis include persistent icterus with high-colored urine and clay-colored or light (alcoholic) stools and hepatomegaly (Fig. 25.7) as a result of poor bile flow because of liver cell injury or bile duct obstruction, and bleeding diathesis as a result of vitamin K insufficiency and

4

Clinical Features

Hematemesis, melena and abdominal distention due to ascites are the commonest presenting symptoms, particularly in a child who had otherwise been doing well.

A respiratory infection may cause severe cough and thereby precipitate a bout of hematemesis due to bleeding from esophageal varices.

It is of interest that ascites may show fluctuation; it usually follows an episode of bleeding.

Don't forget to trace history of a severe infection, umbilical sepsis, dehydration or umbilical vein catheterization for exchange transfusion (prolonged and difficult) in neonatal period or early infancy.

Splenomegaly with or without hepatomegaly is the most constant sign.

Diagnosis

Liver function tests and liver biopsy are essentially normal.

Upper GI endoscopy or *Barium swallow* may reveal esophageal and gastric varices in 80 per cent of the cases.

Ultrasound is an excellent screening test for defining the site of the disease.

Confirmation of the diagnosis is by demonstration of high splenic pulp pressure, i.e. above the cut-off level of 12 mm Hg, and the block by simultaneous splenic portography.

Table 25.9: Etiology-cum-differential diagnosis of neonatal cholestasis

<i>Infections</i> Hepatitis A, B and C, STORCH group of infections, septicemia/sepsis
<i>Metabolic</i> Galactosemia, fructosemia, glycogenosis IV, alpha-antitrypsin deficiency, cystic fibrosis, hypothyroidism, hypopituitarism, Gaucher disease, Niemann-Pick disease, Wolman disease, tyrosinemia, Zellweger (cerebrohepato-renal) syndrome, bile acid metabolic defects, neonatal iron storage disease, copper overload (ICC), arginase deficiency, mitochondrial DNA depletion
<i>Genetic/Chromosomal</i> Down syndrome, Trisomy E, leprechaunism
<i>Intrahepatic</i> Idiopathic neonatal hepatitis, intrahepatic cholestasis, intrahepatic biliary hypoplasia
<i>Extrahepatic</i> Extrahepatic biliary atresia, choledochal cyst, inspissated bile syndrome (bile/mucus plug, bile duct stenosis, mass (neoplasia, stone)
<i>Miscellaneous</i> Drugs, TPN, histiocytosis, shock, enteritis, intestinal obstruction, neonatal lupus erythematosus, myeloproliferative disease

hypoprothrombinemia because of hepatic synthetic dysfunction.

Diagnosis

Since clinical features hardly provide any concrete clues regarding the underlying cause of cholestasis, a recourse to investigations becomes mandatory (Table 25.10). Nevertheless, the following important points in history and clinical workup must be borne in mind:

- Presence of cataract and cherry-red spots point to galactosemia and lipid storage disease, respectively.



Fig. 25.7: Neonatal cholestasis syndrome. Note massive ascites on top of cirrhotic liver secondary to extrahepatic biliary atresia (EHBA)

Table 25.10: Investigative workup for suspected neonatal cholestasis

<i>Blood</i> Total and fractional bilirubin, transaminases, alkaline phosphatase, prothrombin time
<i>Serology</i> Evidence of infections (HBsAg, specific viral serology, VDRL)
<i>Blood, urine, spinal fluid cultures</i> For bacteria, herpes simplex, CMV, enteroviruses
<i>Ultrasonography</i> is particularly of value in identifying such surgically correctable conditions as choledochal cysts
<i>Radionuclide</i> hepatobiliary scintigraphy is of great value in excluding EHBA
<i>Liver biopsy</i> is vital in differentiating between surgical and nonsurgical cases of cholestasis.

- Detection of chorioretinitis means an intrauterine infection like toxoplasmosis, rubella, cytomegalovirus (CMV)
- Higher birth weight, earlier onset of icterus with clay-colored stools, coexistence of congenital malformations and absence of familial occurrence are points in favor of EHBA rather than neonatal hepatitis.

Management

Nutritional support is central to any treatment offered to infants with cholestasis. It is advisable to provide medium-chain triglycerides (coconut oil) for enhancing fat and energy assimilation and fat soluble vitamins to makeup for their poor absorption. Anorexic infants should receive nasogastric feeding.

Replacement therapy may be warranted in the form of fat-soluble vitamins (A, E, D, K), water-soluble vitamins and micronutrients (calcium, phosphate, zinc).

Treatment of pruritus is in the form of phenobarbital, choleretics (ursodeoxycholic acid), or bile acid binders (cholestyramine), rifampicin, naloxene, terfenadine, or 3-4 minute/day phototherapy with ultraviolet or infrared rays.

Chemotherapy for sepsis, especially in the presence of ascites and end-stage liver disease.

Appropriate treatment of associated complications such as variceal bleed (endoscopic sclerotherapy, ascites, hepatic encephalopathy, renal failure).

Surgical treatment is indicated in EHBA and choledochal cyst, provided that liver damage has not advanced to the stage of cirrhosis.

Liver transplantation may be done in end-stage liver disease (liver failure) in case the family can afford it.

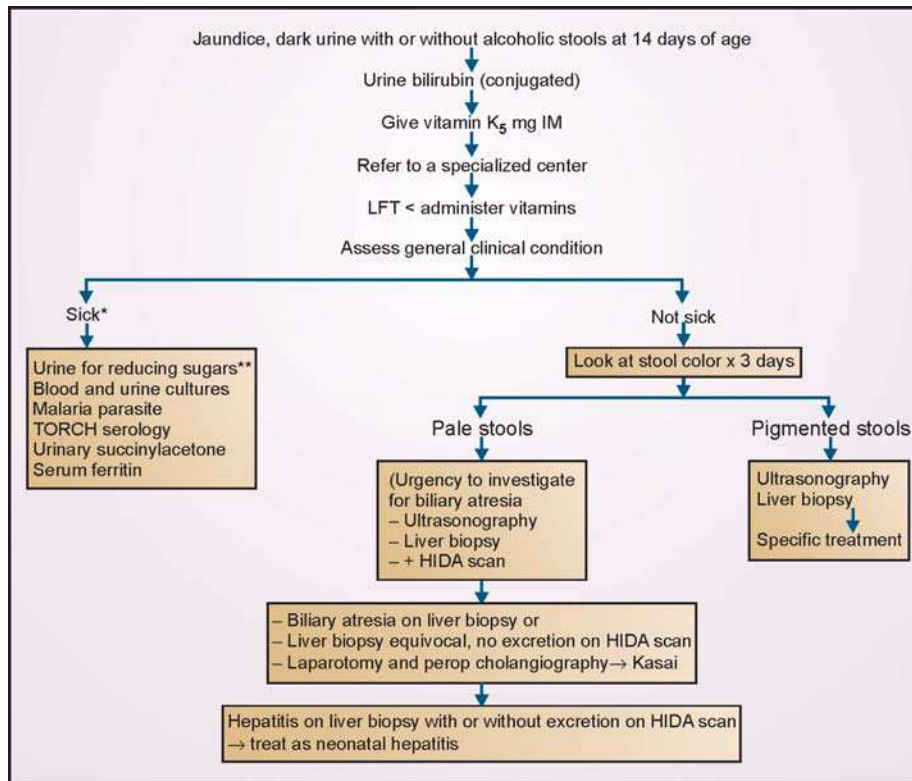
Flow chart 25.1: Algorithm on approach to neonatal cholestasis syndrome (NCS) as per the IAP Subspecialty Chapter 24 (Pediatric Gastroenterology)

* Babies with NCS due to infections of herpes, toxoplasmosis and rarely CMV may be sick, look for their extrahepatic manifestations. Stop milk feeds till galactosemia is ruled out. In febrile babies, look for malarial parasite, sepsis and UTI.

** This is to look for galactose in urine while on milk feeds. If reducing substances are positive, check urine samples with glucose stick. If negative, most likely reducing substances in urine are due to galactose. Treat as galactosemia

A practical algorithm has been suggested as per the IAP Subspecialty Chapter 24 (Pediatric Gastroenterology) (Flow chart 25.1).

Prognosis

On account of delayed diagnosis and referral in a vast majority of infants with NCS, prognosis is unfavorable. In idiopathic neonatal hepatitis of sporadic variety, 60-70% cases recover whereas in the familial variety recovery occurs in only 20-30% cases, the remaining cases ending up as chronic liver disease with cirrhosis.

EXTRAHEPATIC BILIARY ATRESIA

See Chapter 40 (Pediatric Surgery).

CHOLEDOCHAL CYST

See Chapter 40 (Pediatric Surgery).

CHOLECYSTITIS

Cholecystitis with Cholelithiasis

When cholecystitis occurs in association with cholelithiasis, some predisposing factors such as chronic hemolytic disease (thalassemia, sickle cell anemia, red blood cell enzymopathies), obesity, Wilson disease, ileal disease, bile acid malabsorption, etc. are usually present. Gallstones from a mixture of cholesterol, bile pigment calcium, and inorganic matrix, are the most common variety followed by pure cholesterol or pure bile stones.

Clinical features of cholecystitis with cholelithiasis include recurrent colicky pain in the right upper quadrant of abdomen, intolerance for fatty foods, pyrexia and a palpable lump.

Ultrasound is the investigation of choice for gallstone detection.

Cholecystectomy is curative. Alternatively, oral chenodeoxycholic acid or extracorporeal lithotripsy may be employed for dissolution of the stones.

Acute Acalculous Cholecystitis

Acute acalculous cholecystitis may develop secondary to infections, e.g. *Streptococcus* group A and B, gram-negative pathogens like *Salmonella*, *L. giardia*, *Asc. lumbricoides*, etc. abdominal trauma, periarteritis nodosa and other systemic vasculitis, and Kawasaki disease.

Clinical features include right upper quadrant or epigastric pain, nausea, vomiting, pyrexia, and jaundice. Examination reveals right upper quadrant guarding and tenderness.

Diagnosis is by ultrasound that shows an enlarged and thick walled gallbladder without stones. Supportive laboratory findings are high TLC, serum alkaline phosphatase and conjugated bilirubin.

Treatment revolves round therapy for primary infection and cholecystectomy in some cases.

DRUG-INDUCED LIVER INJURY

Liver is remarkably vulnerable to insult from certain drugs because of its vital role in drug metabolism. Administration of two hepatotoxic drugs increases the chances of liver damage.

Direct (dose-dependent) hepatotoxicity results from such agents as are directly hepatotoxic and disrupt the hepatic cells, cause microsomal and mitochondrial injury and damage the canalicular apparatus. Examples of agents in this category are paracetamol, chlorpromazine, ferrous sulfate, hormones and antimetabolites.

Indirect (dose-independent) hepatotoxicity results as an expression of patient's vulnerability due to hypersensitivity or formation of hepatotoxic metabolites. Both hypersensitivity and abnormal metabolites lead to idiosyncratic reactions. In the former allergic symptoms like rash, fever, eosinophilia and granuloma in the liver are common. Sensitization (latent) period is 1 to 4 weeks and 2 to 52 weeks, respectively. Examples of this category of hepatotoxicity are propoxyphene, nitrofurantoin, mepacrine, chlordiazepoxide, rifampicin and isoniazid.

For diagnosis of drug-induced hepatotoxicity, the following points should be borne in mind:

1. History of drug exposure
2. Manifestations compatible with certain drugs
3. Hypersensitivity symptoms such as rash, fever and eosinophilia in a subject with abnormal LFTs

4. Recurrence of symptoms and hepatic dysfunction following a test dose of the drug in patients in whom the drug needs to be continued. Management consists in immediate withdrawal of the offending drug along with high protein, high calorie diet, cholestyramine, or phenobarbital to relieve pruritus and jaundice. Symptoms resolve within days and biochemical liver function within weeks. Rarely, portal hypertension and fulminant hepatitis may occur in advanced cases.

Hepatomegaly, a common problem in pediatric practice, may be caused by a large number of conditions (Table 25.11).

Table 25.11: Differential diagnosis of pediatric hepatomegaly

Newborn

Infections Intrauterine STORCH group of infections, neonatal hepatitis, septicemia/sepsis, malaria

Metabolic/Storage Galactosemia, fructosemia, glycogenosis IV, alpha-1-antitrypsin deficiency, cystic fibrosis, hypothyroidism, hypopituitarism, Gaucher disease, Niemann-Pick disease, Wolman disease, tyrosinemia

Zellweger (cerebrohepatorenal) syndrome, bile acid metabolic defects, neonatal iron storage disease, copper overload (ICC), arginase deficiency, mitochondrial DNA depletion

Genetic/Chromosomal Down syndrome, Trisomy E, leprechaunism

Intrahepatic Idiopathic neonatal hepatitis, intrahepatic cholestasis, intrahepatic biliary hypoplasia

Extrahepatic Extrahepatic biliary atresia, choledochal cyst, inspissated bile syndrome (bile/mucus plug, bile duct stenosis,

Miscellaneous CCF, drugs, TPN, histiocytosis, shock, enteritis, intestinal obstruction, neonatal lupus erythematosus

Infants

All of above plus viral hepatitis A, B and C and ICC

Childhood and Adolescence

Infections Hepatitis A, B, C, D and E, chronic hepatitis, liver abscess (both amebic and pyogenic), typhoid fever, malaria, hydatid cyst, infectious mononucleosis

Metabolic/Storage ICC Mucopolysaccharidosis, glycogen storage disease, lipidosis, alpha-1-antitrypsin deficiency, Wilson disease

Fatty Change/infiltration Kwashiorkor, Reye syndrome, tuberculosis, cystic fibrosis, tetracycline toxicity

Malignancy Lymphomas, hepatoblastoma, histiocytosis, metastases

Congestive CCF, constrictive pericarditis, Budd-Chiari syndrome, VOD of liver

Miscellaneous Congenital cyst, drugs

HEPATOMEGALY: DIFFERENTIAL DIAGNOSIS

Evaluation of hepatomegaly should include a good history and clinical examination together with liver function tests, ultrasonography and other investigations depending on the merits of each case. More significant than sheer palpability of the liver is the measurement of liver span (Chapter 1). Additional information needed is shape, consistency, surface characters, border, tenderness, murmurs or bruit, and any accompanying splenomegaly. Box 25.4 gives the clues that are helpful in the differential diagnosis of hepatomegaly.

Box 25.4: Helpful clues in evaluation of pediatric hepatomegaly

H/o Sibling/familial involvement	ICC, Wilson disease, thalassemia
H/o transfusions/needle pricks	HBV, HCV
Fever	Enteric fever, malaria, viral hepatitis, leptospirosis (in acute cases)
active	tuberculosis, kala-azar, chronic hepatitis (in chronic cases)
Jaundice	Viral hepatitis, cirrhosis, enteric fever
Edematous PEM	Kwashiorkor
Anemia	Thalassemia, leukemia, portal hypertension
Lymphadenopathy	Hematogenous tuberculosis, malignancy
Engorged neck veins/raised JVP	Constrictive pericarditis
Rash	Histiocytosis
Cataracts with mental retardation and splenomegaly	Galactosemia
Hazy or cloudy cornea	Mucopolysaccharidosis type 1
Kayser-Fleischer ring	Wilson disease
Microcephaly/hydrocephalus	STORCH group of intrauterine infections
Neurologic manifestations	Wilson disease
Refractory rickets	Cystinosis, tyrosinosis

LIVER ABSCESS

Liver abscess(es) may be pyogenic, amebic or, rarely, because of other causes (infected echinococcal cyst, *Candida* infection in immunocompromised subjects or neonates).

PYOGENIC LIVER ABSCESS

Etiology

It is usually polymicrobial, the most common pathogen being *Staphylococcus aureus* in solitary abscess and gram-negative enteric bacilli and anaerobic organisms in multiple abscesses.

Predisposing factors include immunocompromised states (chronic granulomatous disease, ALL, steroid therapy, measles), malnutrition, bile duct ascariasis, skin infections, trauma, aplastic anemia and sickle-cell disease, ventriculoperitoneal shunt, and, in neonates, umbilical vessel catheterization, prematurity, suppurative umbilical thrombophlebitis, peritoneal abscess, skin infection, septicemia, and surgical procedure for necrotizing enterocolitis.

Clinical Features

These include spiky pyrexia with chills and rigors, anorexia, nausea, vomiting, abdominal distention, right upper quadrant abdominal pain and lassitude. Examination may reveal, jaundice (in biliary tract obstruction), tender hepatomegaly or right upper abdominal mass.

Diagnosis

It is confirmed by ultrasonography (Fig. 25.8), CAT scan, or radionuclide scans. Aspirated fluid from the abscess should be cultured aerobically and anaerobically.

Management

It consists of an appropriate chemotherapy (a combination of penicillinase resistant penicillin plus an aminoglycoside or a third generation cephalosporin), percutaneous needle aspiration, catheter drainage and open surgical drainage.

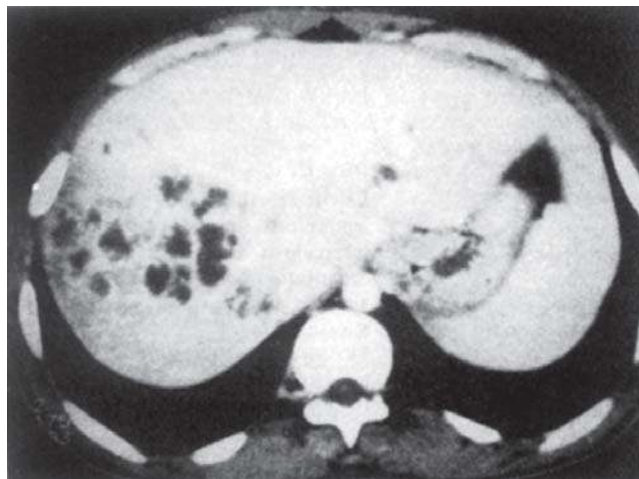

Fig. 25.8: CT scan (contrast enhanced) showing multiple coalescent hypodense areas (right lobe of liver) consistent with pyogenic liver abscesses

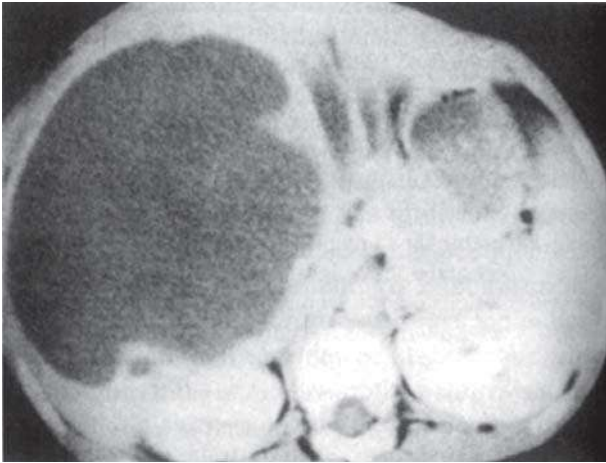

Fig. 25.9: CT scan (contrast enhanced) showing a large hypodense area (right lobe of liver) consistent with a solitary amebic liver abscess

Prognosis

Following prompt diagnosis and appropriate treatment, pyogenic abscess resolves in over 6 weeks.

Complications

These include pleuropulmonary involvement, peritonitis, subphrenic abscess, abscess-duodenum fistula, hemobilia, pericardial effusion and Budd-Chiari syndrome.

AMEBIC LIVER ABSCESS

As already pointed out in Chapter 20, it is extremely difficult to differentiate amebic liver abscess from pyogenic liver abscess on the basis of clinical presentations and imaging modalities (Fig. 25.9). The special investigations for this purpose include serology and liver aspiration under ultrasonography or CT scan.

Treatment is in the form of amebicidal drugs (parenteral metronidazole 20-50 mg/kg/day for 7-10 days as such or in combination with tetracycline or chloroquine; in seriously sick cases, emetine hydrochloride), percutaneous needle aspiration, catheter drainage and open surgical drainage.

WILSON DISEASE

(Hepatolenticular Degeneration)

In this autosomal recessive disorder, there is an excessive increase in copper deposition in liver, brain, kidneys and many other body organs due to inability of the liver to metabolize the normally absorbed dietary copper. Precisely, copper is neither

incorporated into apoceroloplasmin nor secreted into bile. Manifestations appear after 5 years of age and may be predominantly hepatic (acute self-limited hepatitis, chronic active hepatitis, fulminant hepatic failure, cirrhosis) or neurologic, psychiatric, ophthalmologic and renal. Treatment options are dietary restriction of copper, drugs like penicillamine, trientine and zinc, and orthotopic liver transplantation. Also see Chapter 23.

APPROACH TO THE CHILD WITH ASCITES

The term, *ascites*, refers to collection of fluid in the peritoneal cavity. As already described (Chapter 1), free fluid may be detected as shifting dullness with fluid thrill. It may be accompanied by pedal edema, scrotal edema or anasarca.

Etiology

Table 25.12 gives the list of causes of ascites according to age group.

Table 25.12: Etiology of pediatric ascites

Newborn

Isolated Chylous (congenital anomalies of lymphatics), liver failure (hemochromatosis), idiopathic

With peritonitis Chemical (bile, meconium), bacterial

With hydrops Cardiovascular (hypoplastic left heart syndrome, Ebstein anomaly, heart block, auricular tachycardia), hematologic (chronic *in utero* anemia: homozygous alpha thalassemia, isoimmune hemolytic anemia), chromosomal (Trisomy 13, 18, 21, Turner syndrome), infections (STORCH), pulmonary (diaphragmatic hernia), renal (nephrosis, posterior urethral valve), maternal (diabetes mellitus, toxemias), placental (cord compression, chorangioma), storage (mucopolysaccharidosis), tumors (Wilms', neuroblastoma), skeletal (osteogenesis imperfecta, achondroplasia), hepatic (alpha-1-antitrypsin deficiency, hemochromatosis), idiopathic.

Infants and Children

With portal hypertension Extrahepatic (splenic vein thrombosis, portal vein thrombosis, cavernous transformation, Budd-Chiari syndrome, inferior vena cava obstruction, CCF, A-V fistula), Intrahepatic (EHBA, choledochal cyst, hepatitis B and C, Wilson disease, alpha-1-antitrypsin deficiency, toxin-induced, cystic fibrosis, histiocytosis X, schistosomiasis)

Without portal hypertension Tuberculosis, CCF, nephrotic syndrome

Acute Ascites

Hepatic encephalopathy Fulminant liver failure

Peritonitis Spontaneous perforation of bile duct

Venous obstruction Budd-Chiari syndrome, portal vein thrombosis, inferior vena cava obstruction, splenic vein thrombosis, VOD of liver.

Special Diagnostic Investigations

Radiologic studies Ultrasonography is particularly of great value in detecting minimal ascites that may be missed by clinically. Infrequently, CAT scan and/or MRI may be required in difficult cases.

Upper GI endoscopy for detecting presence of esophageal or fundal varices.

Abdominal (ascitic/peritoneal) tap for biochemistry and cytology of the ascitic fluid (Table 25.13). The procedure is described in Chapter 43 (Pediatric Practical Procedures).

Table 25.13: Characteristic features of ascitic fluid in major causes of ascites

Characteristics	Tuberculosis	Portal hypertension/Cirrhosis	Pyogenic
Gross appearance	Clear	Straw-colored/bile-stained	Turbid or purulent
Cell count	TLC > 1000	< 250	> 1000
Protein	Lympho > 70%	Mesothelial 90%	PMN > 50%
Specific gravity	> 2.5 g/dl	< 2.5 g/dl	> 2.5 g/dl
	> 1016	< 1016	>1016

Note: Remarkable rise in amylase level in ascitic fluid (usually > 2000 IU) supports pancreatitis or gut perforation whereas LDH elevation is of value in differentiating bacterial peritonitis from gut perforation (Fig. 25.10).



Fig. 25.10: Massive ascites: Note the prominent thoracoabdominal venous network

Management

Treatment is dictated by the etiologic condition.

Supportive treatment consists of sodium and fluid restriction, diuretics (potassium sparing aldosterone antagonists like spironolactone, loop like frusemide and combination of the two types), and beta-blockers (propranolol).

Refractory ascites may be offered the benefit of a large volume (up to 100 ml) tap, colloidal replacement with dextran or albumin, transjugular intrahepatic post-canal shunt (TIPS), or orthotopic liver transplantation.

ORTHOTOPIC LIVER TRANSPLANTATION (OLT)

Indications

Table 25.14 lists important indications of OLT.

Table 25.14: Major indications of orthotopic liver transplantation (OLT)

Fulminant liver failure	Viral, drug-induced, autoimmune, toxin-induced, perinatal hemochromatosis, Wilson disease, tyrosinemia, idiopathic
End-stage liver failure	Obstructive biliary tract disease: EHBA, sclerosing cholangitis, postsurgical biliary tract diseases Intrahepatic cholestasis: Syndromic bile duct paucity (Alger syndrome), nonsyndromal bile duct paucity, intrahepatic cholestasis, idiopathic neonatal hepatitis Chronic active hepatitis/cirrhosis: Hepatitis B, C, autoimmune, idiopathic Metabolic disorders: Alpha-1- antitrypsin deficiency, Wilson disease, tyrosinemia type 1, glycogen-storage disease (type 1, 3, 4), cystic fibrosis Miscellaneous: Cryptogenic cirrhosis, congenital hepatic fibrosis, TPN-associated cirrhosis
Metabolic disorders	Crigler-Najjar (type 1), primary leading to hepatic disease oxalosis, familial cholesterolemia, urea cycle defects, organic acidemias
Unresectable liver tumors	Hepatoblastoma, hepatocellular carcinoma, hemangioendothelioma, hemangiomas

Contraindication

Only absolute contraindications are advanced cardio-pulmonary or CNS disorder that cannot be reversed by OLT.

Complications

These include septicemia, vascular thrombosis, biliary complications, poor graft function, chronic rejection, renal failure, hypertension, intestinal perforation and hematemesis.

Immunosuppression to Prevent “Rejection”

In order to reduce the frequency of allograft rejection, it is a usual practice to give triple immunosuppression with prednisolone, azathiaprine and cyclosporin post-operatively.

In case of rejection, pulse prednisolone therapy (10 mg/kg/day is given for 3 days. In the event of steroid resistance or cyclosporin-induced renal dysfunction, newer immunosuppressants such as tacrolimus may be employed.

Results

Currently, 1 year and 5 year survival rates are 90% and 80%, respectively.

FURTHER READING

Articles/Chapters

1. Arora NK, Lodha R, Gulati S. Portal hypertension in north Indian children. *Indian J Pediatr* 1998;65:585.
2. Bavdekar SB, Tullu MS, Patankar T. Liver abscess. In Gupte S (Ed): *Recent Advances in Pediatrics (Special Vol. 6: Gastroenterology, Hepatology and Nutrition)*. New Delhi: Jaypee 2000:390.
3. Gupte S, Abrams R. Hepatic coma. In Gupte S (Ed): *Recent Advances in Pediatrics (Special Vol 14: Criticare Pediatrics)*. New Delhi: Jaypee 2004:546.
4. Gupte S. *Differential Diagnosis in Pediatrics*, (5th edn). New Delhi: Jaypee 2008.
5. Sharda B. Viral hepatitis. In Gupte S (Ed): *Recent Advances in Pediatrics (Special Vol. 6: Gastroenterology, Hepatology and Nutrition)*. New Delhi: Jaypee 2000:257.
6. Sibal A. Liver transplantation. In Gupte S (Ed): *Recent Advances in Paediatrics (Special Vol. 6: Gastroenterology, Hepatology & Nutrition)*. New Delhi: Jaypee 2000:377.

Books/Monographs

1. Gupte S, Horvath K. *Pediatric Gastroenterology, Hepatology and Nutrition*. New Delhi: Peepee 2008.
2. Kelly DA. *Diseases of the Liver and Biliary System in Children*. Oxford: Blackwell 1999.

CHAPTER



26

Pediatric Nephrology

Suraj Gupte, RM Shore

BASICS OF THE RENAL SYSTEM

The kidney develops as a penetration of metanephros by ureteric bud, an outgrowth of mesonephric duct during 5th week of gestation. By 36 weeks, full number of nephrons has developed though the functional maturity continues well after birth, usually until 2 years of age.

Nephron, the basic structural and functional unit, consists of a glomerulus and a long tubule consisting of proximal and distal convoluted tubules and collecting ducts. Each kidney contains approximately one million nephrons. The proximal convoluted tubule reabsorbs about 65%, the loop of Henle 15%, the distal convoluted tubule 10% and collecting ducts 9% of the glomerular filtrate. Thus, only 1% of filtrate is excreted in urine.

In order to stabilize plasma bicarbonate at 26-28 mEq/L, the filtered bicarbonate is mostly reabsorbed in the proximal convoluted tubules. Major urinary acidification is done through ammonia excretion and titratable acid.

Urinary concentration is maintained at 280-290 mOsm/kg. In this endeavor, ADH plays an important role. It acts on collecting ducts, thereby facilitating passage of water from lumen to hyperosmotic interstitium.

As blood passes through glomerular capillaries, plasma is filtered. The cell-free ultrafiltrate contains all substances in plasma, i.e. electrolytes, glucose, phosphate, urea, creatinine, peptides, low molecular weight proteins except proteins having a molecular weight > 68000. Glomerular filtration is the net result of opposing forces across the capillary wall, namely

the force for ultrafiltration, *glomerular capillary hydrostatic pressure*, and the force opposing ultrafiltration, *glomerular capillary oncotic pressure*.

In case of a newborn, function is insufficient as compared to grown-up children or adults. GFR at birth is as low as 10-20 ml/min/1.73 m². It rises to 75-80 ml/min/1.73 m² by 6 weeks. High serum creatinine at birth falls to 0.4 mg/dl by 7th day of life. Sodium and bicarbonate reabsorption and hydrogen ion excretion are limited. As a result the newborn's pH of urine is far higher than the magnitude of acidemia. Renal function continues to improve until it approaches adult level by end of 2 years.

DIAGNOSTIC WORK-UP FOR RENAL DISORDERS

Clinical Evaluation

A good history and clinical examination are mandatory for diagnostic workup of a renal disease. Such clinical features of renal disease as change in micturition habit, edema, hematuria, oliguria/anuria, dysuria, pain in flanks, ureteric colic, enuresis, growth retardation, anemia and abdominal lump should be kept in mind. Remember, a serious renal disorder may linger on without any overt manifestations.

Common problems of neonatal period are congenital malformations. In age group infancy-3 years, UTI, Wilms' tumor, multicystic renal dysplasia, HUS, nephrotic syndrome, renal tubular acidosis and Fanconi syndrome are seen. In 3-6 years group, nephrotic syndrome, acute nephritis, rickets (usually secondary) and HUS are relatively frequent. Beyond

6 years (including adolescence), common problems are acute nephritis, nephrotic syndrome (usually non-minimal variety), chronic renal failure, symptomatic hypertension and collagenosis.

Investigative Evaluation

- *Urinalysis*, an important part of investigative evaluation, involving appropriate collection and tests for protein and glucose plus microscopy, is described in details in Chapter 44.
- *Blood levels of creatinine* (normal < 6 years 0.2-0.5 mg%, > 6 years 0.4-0.8 mg%) and *urea* (normal 20-40 mg%); pH, bicarbonate, electrolyte and osmolality in tubular disorders and renal failure.
- *Serum albumin, cholesterol, ASO titer, complement level, immunoglobulins* and autoantibodies depending on merits of the case.
- *Glomerular filtration rate (GFR)* is measured by creatinine clearance. Its normal value varies between 100 and 125 ml/minute/1.73 m². GFR is, however, best measured by inulin clearance which is a cumbersome technique. Radionuclide clearance is yet another method of accurately computing GFR.
- *Urine concentration test* following fluid deprivation and measuring urine osmolality or administering desamino-8-D-arginine vasopressin (DDAVP) nasally or IM injection and measuring urine osmolality.
- *Imaging of urinary tract by plain X-ray, IVP, ultrasonography (US), micturating cystourethrogram (MCU), radionuclide imaging, etc.*

CONGENITAL MALFORMATIONS OF KIDNEY AND URINARY TRACT

Congenital defects of urinary tract are found in about 8% to 10% of children, majority of them producing no significant problem. Yet, approximately one-fourth of pediatric chronic renal failure is secondary to such malformations. These are outlined in Table 26.1.

Clinical clues for developmental anomalies of kidney and urinary tract include lowset/malformed ears, Potter facies, oligohydramnios, fetal compression syndrome, Trisomies 13 and 18, tuberous sclerosis, Wilms' tumor, meningomyelocele, sacral anomalies, spinal and lower limb defects, imperforate anus, genital anomalies, cystic disease of liver, hepatic fibrosis, single umbilical artery and family history of renal disease.

Table 26.1: Congenital malformations of kidney and urinary tract

Kidney

Renal agenesis, horse-shoe kidney, polycystic disease of kidneys, duplex renal system, pelviureteric function stenosis.

Bladder and urethra

Ectopia vesicae, patent urachus, bladder-neck obstruction, posterior urethral valves, neurogenic bladder, hypospadias, phimosis, structural defects of meatus or urethra.

Renal Agenesis

Bilateral renal agenesis is not compatible with postnatal life, the stillborn showing stigmata of prenatal renal failure and oligohydramnios in the form of characteristic *Potter facies* (widely-separated eyes with epicanthal folds, broad and flat nose, small and receding chin and lowset ears), and limb malformations. Associated anorectal, cardiovascular and skeletal anomalies are common.

Unilateral renal agenesis must be excluded in neonates with single umbilical artery. It is usually accompanied by enlargement (compensatory) of the contralateral kidney, and such anomalies as involving the genitourinary tract (40%), skeletal system (30%), CVS and GIT (15%), and CNS and respiratory system (10%). When it is accompanied by vaginal agenesis or atresia, the combination is termed *Mayer-Rokitansky syndrome*.

Horse-shoe Kidneys

When lower poles of the kidneys are fused in the midline, the condition is called *horse-shoe kidneys*.

The incidence is remarkably high in Turner syndrome – 7% against 1:500 in random births. Such kidneys are 2 to 8 times more vulnerable to develop Wilms' tumor than in general population.

Polycystic Disease of Kidneys

It is of two types:

- *Infantile type* It is inherited as an autosomal recessive disease. The renal tissue is full of multiple small cysts and the organ is palpable as "large spongy kidney of newborn". Polycystic disease is often present in liver, lungs and pancreas. Hypertension, CCF and uremia usually prove fatal in early infancy.
- *Adult type* It is inherited as an autosomal dominant disease. Multiple cysts are present in both kidneys. Decrease in renal function may not manifest before the age of 40 years.

Duplex Renal System

The term refers to a kidney with double pyelocalyceal systems with single, bifid, or two ureters.

Pelviureteric Junction (PUJ) Stenosis

It may be unilateral or bilateral, presenting as a flank lump without any symptoms or with UTI and upper abdominal pain.

Posterior Urethral Valves

These may present as recurrent UTI, dribbling, abnormal urinary stream, palpable bladder and renal dysplasia. Diagnosis is clinched by micturating cystourethrogram (MCU) which shows dilated posterior urethra, valves at the point of its junction with anterior urethra, enlarged bladder with vesicoureteric reflux (VUR).

4 Meatal Stenosis

Rarely, considerable stenosis of urethral meatus may cause urinary tract obstruction. Meatal dilatation or meatoplasty relieves the obstruction.

Phimosis and Paraphimosis

Inability to retract the prepuce after the age of 3 years only should be regarded as *true phimosis*.

The prepuce is usually unretractable at birth but in 90% instances it becomes retractable by the age of 3 years. By adolescence, only 1% boys have phimosis.

Phimosis may be congenital or secondary to inflammatory condition(s) of the glans or prepuce.

Standard treatment is circumcision. Alternatively, betamethasone cream may be applied to the narrowed preputial skin twice daily for 4 weeks. After 2 weeks, the foreskin becomes soft and elastic and is retracted gently and gradually in increments. In a vast majority of the cases, the treatment proves successful.

Paraphimosis means that once the prepuce (phimotic) is retracted behind coronal sulcus, it cannot be reduced, causing venous stasis and edema with severe pain. Advanced cases need circumcision. In others, reduction can be attained by application of lubricants under cover of heavy sedation.

Antenatal Diagnosis of Developmental Anomalies

Antenatal diagnosis is possible by ultrasonography, especially of hydronephrosis because of pelviureteric

junction (PUJ) obstruction, anomalies of vesicoureteric junction, vesicoureteric reflux, posterior urethral valves, neurogenic bladder and nonobstructing megaureters. However, the diagnosis needs to be reconfirmed after birth by renal ultrasonography at 4-7 days and, if negative, again at the tailend of first month of life. Indications of surgery are progressively worsening renal function, persis-tent/recurrent UTI, or hypertension.

NEUROGENIC BLADDER

This condition is characterized by urinary retention. The hypertrophied bladder, usually associated with meningomyelocele, empties partially or overflows periodically. High frequency of urinary tract infection and hydronephrosis are often found in such children.

Neurogenic bladder, for short periods, may be found in CNS infections like meningitis and encephalitis.

The treatment is surgical bypass of the bladder by urinary diversion into an ileal bag.

OBSTRUCTIVE UROPATHY

Congenital malformations such as valves, neuromuscular bladder dysfunction, diverticulum, stricture, meatal stenosis, etc. (as also acquired conditions like calculi, blood clots, fungus balls, trauma, tumors, foreign body, tuberculosis) may produce urinary tract obstruction.

Predisposing Factors

- History of hydramnios in the mother during pregnancy
- Prune-belly syndrome
- VATER association (*V* for vertebral defects, *A* for imperforate anus, *T* for tracheoesophageal fistula with esophageal atresia and *R* for radial and renal dysplasia)
- Chromosomal defects, e.g. Down syndrome, XO, 13-15 and 16-18 trisomies
- Congenital heart disease
- Absent/deformed pinna
- Preauricular pits
- Hypospadias
- Sacral agenesis
- Anorectal malformations

Manifestations

These include polydipsia, polyuria, anemia, failure to thrive, chronic irritability, recurrent urinary tract infection, weak or forceful stream, enuresis, salt wasting and hyponatremia. Azotemia, hypocalcemia, hyperphosphatemia, and hyperchloremic metabolic acidosis are often present. Some degree of hydro-nephrosis is usual, so is hypertension. Vitamin-D-resistant rickets are likely to develop in due course of time. Distal tubular dysfunction characterized by impairment of the urinary concentration and acidification, as also disturbance of renal hydroxylation of vitamin D contribute to the development of these abnormalities.

Obstructive uropathy is usually detected fairly late so much and so that considerable damage is already caused.

Diagnosis

Radiologic studies show renal osteodystrophy (rickets with osteoporosis). IVP for site of obstruction, voiding cystourethrogram for posterior urethral valves or vesicoureteral reflux, and ultrasound for locating the site of obstruction more precisely are helpful tools.

Treatment

It is primarily surgical correction or bypass of the obstruction. Correction of acidosis along with supportive measures is important.

PROTEINURIA

The term is employed when more than 150 mg (0.15 g) protein is found in urine in 24 hours. The share of albumin is only 30 mg/ 24 hours.

Measurement of urine protein is by boiling test including treatment with sulfosalicylic acid, dipstick test, 24-hour urine collection, and urine protein/creatinine ratio which quantitates proteinuria when timed urine collection is not possible.

Proteinuria may be benign or organic.

Benign proteinuria Proteinuria in this category is never more than 1 g/24 hours and is never accompanied by edema. It may be postural (orthostatic), febrile, or exercise-induced.

In postural (orthostatic) proteinuria, there is 10-fold or greater increase in urine protein, in the upright

position. There are no symptoms and no investigative abnormalities of the urinary tract. Though apparently a benign condition, a long-term follow-up of the child is warranted.

In febrile proteinuria, a body temperature above 38.3°C (101°F) may cause some proteinuria which resolves once fever is controlled.

In exercise-induced proteinuria, vigorous exercise may be followed by proteinuria which resolves after 48 hours of rest.

Organic proteinuria It may be secondary to tubular or glomerular disorders.

Tubular proteinuria is characterized by migration of low molecule weight protein mainly in the alpha and beta regions so that very minimal albumin is detected in urine. It may be hereditary or acquired.

Hereditary (congenital) tubular proteinuria may accompany cystinosis, Wilson disease, Lowe syndrome, proximal renal tubular acidosis and galactosemia.

Acquired tubular proteinuria may accompany antibiotic therapy, heavy metal poisoning (mercury, gold, lead, chromium, copper, cadmium), interstitial nephritis, acute tubular necrosis and cystic diseases.

Glomerular proteinuria results mostly because of increased permeability of the glomerular capillary wall. It may be "selective" when there is a loss of proteins of molecular weight up to and including albumin (as in minimal-change nephrotic syndrome), or "nonselective" when there is loss of albumin and larger molecular weight protein like IgG (as in case 24. of most forms of glomerulonephritis).

Etiologic conditions leading to glomerular proteinuria include persistent asymptomatic proteinuria, nephrotic syndrome, glomerulonephritis, tumors, drugs, etc.

HEMATURIA

The appearance of more than 5 red cells per high power field in the sediment of a 10 ml of centrifuged fresh specimen of urine is termed *hematuria*.

Hematuria may be gross (macroscopic: visible to the naked eye) or microscopic (detected only by microscopic examination or dipstick of urine sediment).

Gross hematuria originating from kidneys gives urine brown or cola/tea color. In case it originates from lower urinary tract (bladder and urethra), urine has a bright red or pink color and may show up clots.

In microscopic hematuria, color of urine remains normal. This form of hematuria is detected only by microscopic examination or by dipstick of the urine sediment.

It is pertinent to determine if hematuria is “total”, “initial”, or “terminal”. Total hematuria is indicative of a lesion above the bladder neck. Initial hematuria points to the source of blood along the urethra. In terminal hematuria, areas last to be emptied of urine (trigone, bladder neck, prostate) are the source of bleeding. A spotting of blood on the undergarments shows that blood is coming from urethra distal to the sphincteric mechanism.

Note that colored urine may result from factors other than blood. For instance, dark yellow urine may simply be the result of excessive concentration or bile pigments. Red urine may result from myoglobin, porphyrins, beets, black berries, red food coloring, phenolphthalein, urates or pyridium. Homogentisic acid may impart the urine dark brown or black color.

Etiology

Table 26.2 lists important causes of hematuria. It is noteworthy that microscopic hematuria need not essentially be a sign of renal disease. It may result from heavy exercise, viral or bacterial infections, drugs, etc.

Diagnosis

Diagnostic evaluation must begin with accurate history and physical examination. Make sure if the patient is on any drug, etc. that may color the urine. Is there accompanying dysuria? Any fever, periorbital edema, backache or abdominal pain (flank, suprapubic)? Has there been any recent trauma? Any history of insertion of a foreign body into the urethra? Did the patient have a systemic infection recently? Any preceding skin or upper respiratory infection that could be a precursor of acute nephritis? Any bleeding disorder in the patient or a family member? A complete physical examination, including blood pressure determination, is vital. Never miss looking for edema. The perineum and urethra need to be carefully examined.

It is mandatory to demonstrate presence of red cells in urine microscopically. Red color of urine may well be secondary to hemoglobinuria, myoglobinuria,

Table 26.2: Noteworthy causes of pediatric hematuria

Renal Diseases

Acute poststreptococcal glomerulonephritis
 Recurrent gross hematuria/persistent gross hematuria
 IgA nephropathy (Berger nephropathy)
 Idiopathic (benign familial) hematuria
 Alport syndrome
 Membranous glomerulopathy
 SLE nephropathy
 Membranoproliferative glomerulonephritis
 Nephritis of chronic infections
 Rapidly progressive glomerulonephritis
 Goodpasture disease
 Anaphylactoid purpura
 Hemolytic uremic syndrome
 Infections
 Bacterial
 Infective endocarditis
 Tuberculosis
 Hematologic diseases
 Coagulopathies
 DIC
 Thrombocytopenia
 Hemophilia
 Sickle cell disease
 Renal vein thrombosis
 Stones and hypercalciuria
 Anatomic abnormalities
 Congenital malformations
 Polycystic kidneys
 Vascular abnormalities

Drugs

Cyclophosphamide	Phenytoin
Aspirin	PAS Anticoagulants
Kanamycin sulfas	Cephalosporin
Aminophylline	Bacitracin
Troxidone	Methicillin
	Penicillin

Miscellaneous

Exercise (vigorous)
 Severe perinatal hypoxia
 Neoplasm
 Wilms' tumor
 Bladder papilloma
 Trauma
 Idiopathic hypercalciuria
 Factitious hematuria (Munchausen syndrome by proxy)

beeturia and metabolic products of certain drugs or poisons. A grossly bloody urine that fails to show large number of red cells points to intravascular hemolysis resulting in hemoglobinuria, or myoglobinuria.

All children with established hematuria (gross) should be investigated stepwise (Box 26.1).

Box 26.1: Stepwise investigations of gross hematuria

Step 1 relates to studies performed in all subjects: (1) Complete blood count, (2) Urine culture, (3) Serum creatinine level, (4) 24-hour urine collection for creatinine, protein, calcium, (5) Serum C3 level, and (6) Ultrasound or IVP.

Step 2 relates to studies performed in selected subjects: (1) DNase B titer or streptozyme test if hematuria is of less than 6 months duration, (2) Skin or throat cultures when appropriate, (3) ANA titer, (4) Urine erythrocyte morphology, (5) Coagulation studies/platelet count when suggested by history, (6) Sickle cell screening in all black patients, (7) Voiding cystourethrography with presence of infection or when lower tract lesion is suspected.

Step 3 relates to invasive procedures such as renal biopsy and cystoscopy.

Renal biopsy is indicated for: (1) Persistent high grade microscopic hematuria, (2) Microscopic hematuria plus any of the following: diminished renal function, proteinuria exceeding 150 mg/day (0.15 g/day), hypertension, and second episode of gross hematuria.

Cytoscopy is indicated for pink to red hematuria, dysuria, and sterile urine culture.

Treatment

Treatment depends on the causative factor(s) plus the accompanying complications.

URINARY TRACT INFECTION (UTI)
(Pyelonephritis)

Urinary tract infection is quite common in infancy and childhood, including neonatal period. Since its manifestations may often be absent or slight in pediatric patients, many a times it remains undetected until much damage has been caused to the kidneys. In our experience, its incidence in the hospitalized children is as high as 8%. Some of them are admitted for some other ailment without any symptoms referable to urinary tract. This observation has been confirmed by other workers as well.

Etiologic Considerations

UTI is decidedly more common in girls. Favorable anatomic factors render the female urinary tract more susceptible to ascending infection.

Presence of congenital anomalies, like bladder-neck obstruction, neurogenic bladder and urethral valves, predisposes to recurrent UTI.

Infection of skin may also act as a focus for hematogenous spread of the bacteria to the urinary tract.

Another predisposing factor is the urethral catheterization.

Among the causative bacteria, *E. coli* is the most common. *Streptococcus*, *Staphylococcus*, *Proteus*, *Klebsiella*, *Pseudomonas* and *Enterobacter* figure among other organisms that may cause UTI.

Clinical Features

The onset may be acute or insidious. In symptomatic cases, manifestations include fever. It may be high and accompanied by chills, urinary frequency, painful micturition, pain in loin, vomiting, delirium, and sometimes, convulsions. Nonspecific manifestations may be in the form of anorexia and irritability. A child may start wetting his bed after having had dry nights. Excessive vomiting may cause dehydration. The same can happen when UTI presents as diarrhea which is not unusual. Occasionally, it may present as meningism. Jaundice may occur, especially in infants.

Thus, it should be remembered that UTI of childhood is a great mimicker. It may simulate acute abdomen, meningitis or diarrhea.

Diagnosis

The characteristic finding is pyuria. Since it may be absent at one or the other stage, repeated examinations of urine should be done carefully. Slight proteinuria and hematuria may occur.

Urine culture is the gold standard for diagnosis of UTI. The best is to culture, within an hour, the freshly voided midstream specimen of urine. In infants and neonates, you may need to obtain urine by suprapubic bladder aspiration or urethral catheterization.

Anemia is present in a long-standing UTI. TLC and ESR are high.

Imaging studies (ultrasound, DMSA renal scan, micturating cystourethrogram) are strongly indicated in case of UTI under the age of 2 years and recurrent UTI in older children.

Treatment

Asymptomatic bacteremia need no treatment.

The major aim of management is preventing renal scarring and its complications in symptomatic UTI.

Children <3 months age and those with complicated UTI (high fever, i.e. >39°C, persistent vomiting, dehydration, renal angle tenderness) need to be hospitalized and preferably treated with parenteral antibiotics to begin with.

As soon as diagnosis of UTI is made on the basis of quantitative pyuria, specific chemotherapy, to eradicate the infection, should be initiated. The drug that the physician considers most appropriate should be started. Later, if necessary, it may be changed depending on the culture and sensitivity report as also on patient's response.

A large number of chemotherapeutic agents, ranging from sulfonamides through amoxycillin and naladixic acid to cephalosporins, are available. The physician is often in a doldrum as to which one to give to his patient. **Currently, the choice should be from amoxycillin, cotrimoxazole, nalidixic acid, ampicillin, nitrofurantoin and oral cephalosporins.**

In case of neonates, ampicillin with gentamicin (or another aminoglycoside), cefotaxime or ceftriaxone is recommended may be employed in an acutely sick child. Quinolones like norfloxacin and ciprofloxacin, though very useful in adults with UTI, are yet to be adequately evaluated in pediatric UTI. Periodic examination of urine, until the patient gets cured, is essential.

One to two weeks is a sufficiently adequate treatment period for acute uncomplicated urinary tract infection. Continuation of therapy for a longer period has no distinct advantage. For a recurrence, medication may be given for 2 to 4 weeks.

A single bolus dose of chemotherapy in childhood UTI, using agents such as fosfomycin trometamol (monuril), is effective.

If the response is poor or frequent recurrences of the infection occur, ultrasonography is indicated. More sophisticated imaging studies include voiding cystourethrography (VCUG) under 2 years age and DMSA scan under 5 years age. If correctable surgical lesions are present, these require repair.

For frequently-recurring UTI, a prolonged prophylactic therapy for a year or even more may be given in doses that are only half of the recommended

for an active infection. Moreover, the total dose may be given only once a day at bedtime.

Supportive measures include:

- Control of high pyrexia by tepid sponging and/or an antipyretic agent.
- A liberal fluid intake.
- Alkalinization of urine to provide relief from dysuria.

Remember, asymptomatic UTI (normal children, especially girls, who show significant bacteruria on screening) does not warrant any specific treatment except for advice on personal hygiene.

ACUTE GLOMERULONEPHRITIS

Acute nephritis or glomerulonephritis is characterized by sudden onset of hematuria, oliguria, edema and hypertension. It occurs most often beyond the age of 2 years. Males suffer more frequently.

On an average, it is responsible for about 2 to 4% of pediatric admissions in India through the incidence in the western countries is far less. About 90% renal disease of childhood is accounted by it.

Etiopathogenesis

In all probabilities, it results secondary to a preceding streptococcal (*beta-hemolyticus type 12*) infection of throat or skin. A history of upper respiratory infection, infected scabies or impetigo, 7 to 14 days previously, is positive in most of the patients.* In some it may complicate scarlet fever.

It is believed to be an immune-mediated disease.

Pathologically, the kidney suffers as a result of "trapping in" of the soluble antigen-antibody complexes. Kidney biopsy shows proliferation and swelling of the endothelial cells. This leads to diminished blood flow through the kidney.

Clinical Features

A typical case suffers from sore throat or streptococcal infection elsewhere. This is followed 1 to 2 weeks later by acute onset of fever, puffiness of the face (especially around the eyes), and smoky or frankly bloody urine. The child may have vomiting,

* Unlike the experience in the Europe, the antecedent streptococcal infection in Indian patients is most often that of skin rather than respiratory tract

headache, malaise and oliguria. Variable degree of hypertension is usual. Occasionally, the child may be brought to the hospital in a state of hypertensive encephalopathy. Acute renal shutdown and CCF are the other serious complications that may occur.

The manifestations in some cases may be too mild to persuade the parents to bring the child to the hospital. Nephritis in such cases may never be detected. In others, several urine examinations may be needed to be sure of the diagnosis.

Diagnosis

Any child who suddenly starts passing smoky, dirty-brown urine, especially if associated with puffiness of the face, should be investigated for acute nephritis.

Urinalysis shows mild to moderate albuminuria, few to several red cells, few pus cells and many granular casts. The output is reduced.

ASO titer and ESR are usually high. Blood urea touches the upper limit of normal or may be slightly increased. The same is true of potassium.

Since most of the cases have already been given antibiotics before they land up in the hospital, throat swab may only occasionally show streptococci.

Differential Diagnosis

It is from hemolytic uremic syndrome, acute glomerulonephritis occurring in vasculitis (anaphylactoid purpura, SLE, polyarteritis nodosa, Wegener granulomatosis), membranoproliferative glomerulonephritis, hepatitis B, infective endocarditis, acute pyelonephritis, nephrotic syndrome accompanied by hematuria, IgA nephropathy and familial nephropathy (Alport syndrome). These conditions are easily excluded by their associated features.

Complications

A child suffering from acute nephritis is at a potential risk of one or more of the following serious complications:

- Hypertensive encephalopathy
- Congestive cardiac failure
- Acute renal failure.

Treatment

During acute phase, bedrest (flexible) and restriction of proteins, salt, and fluids are desirable. This is more so when oliguria is present. As soon as the clinical

state returns to normal, child should be permitted a normal activity as well as intake.

Antibiotic cover, preferably with penicillin, should be given for about a week or so for the coexisting pharyngitis or pyoderma.

Apart from the aforesaid measures, the treating physician should keep an eye on the possibility of complications. Significantly high blood pressure should be treated with nifedipine, atenolol, reserpine, propranolol or alpha-methyldopa. For convulsions, it is better to avoid phenobarbital* and use some other anticonvulsant like diazepam.

CCF may need adequate digitalization and/or IV frusemide. A venesection with removal of 100-200 ml blood or application of rotating tourniquets to decrease venous return to heart. Dopamine infusion is also of value.

For renal failure, the best treatment is peritoneal dialysis. Initially, hypertonic solutions to get rid of the excess fluid and the isotonic solutions to bring down the high blood urea and potassium levels are of value. Other measures for hyperkalemia include administration of cation-exchange resins and 10% glucose with small doses of insulin.

Anabolic steroid are advocated by some authorities to minimize catabolism. We resort to this therapy in case of long-standing failure only.

Prognosis

As a rule, prognosis in acute nephritis is excellent. About 1 to 5% may die and another around 1 to 5% pass on to chronic glomerulonephritis. The rest of the 95% patients completely recover though hematuria may persist for many months or 1 to 2 years. Hypertension usually takes 2-3 weeks to settle. Recurrences are infrequent.

But, remember, that is the time-honored concept. Recently, several reports have suggested that the long-term prognosis of acute glomerulonephritis may not be as favorable as was previously thought. In one series, 50% of the patients continued to have persistent hypertension, proteinuria and reduction in glomerular filtration rate.

RENAL TUBULAR DISEASES

Renal Tubular Acidosis (RTA)

This state is characterized by hyperchloremic metabolic acidosis resulting from defective urinary

* Phenobarbital may accumulate to dangerous level in patients with poor renal function. It is almost entirely excreted by the kidneys

acidification. Three major varieties are recognized, viz:

1. Type I (distal RTA)
2. Type II (proximal RTA)
3. Type IV (mineralocorticoid deficiency) A variant of type II has been called type III.

Type I (Distal RTA) It occurs as a deficiency of secretion of hydrogen ion (urinary ammonium and titrable acid) by distal tubule and collecting duct, increased back diffusion of hydrogen ions, or, perhaps, some other mechanism. Severe hyperchloremia and moderate hypokalemia result from loss of sodium bicarbonate. Despite severe systemic acidosis, pH of urine cannot be reduced below 5.8.

Manifestations include failure to thrive, muscular weakness, paralysis, dehydration, pyrexia, polyuria, polydipsia, refractory rickets and nephrocalcinosis.

It may occur as an isolated condition, or secondary to interstitial nephritis (as in pyelonephritis, obstructive uropathy, SLE, sickle-cell nephropathy, cirrhosis, Ehler-Danlos syndrome, nephrocalcinosis, transplant rejection, etc), and toxins (amphotericin B, lithium, toluene, etc).

Alkali, 3 mEq/kg/day, under careful monitoring, corrects the acidosis.

Type II (Proximal RTA) It results from reduced reabsorption of bicarbonate by proximal tubules which is ascribed to deficient carbonic anhydrase production. The distal tubules having a capacity to reabsorb a maximum of 15% of the filtered load fail to cope with 40% of the filtered load. Around 25% of it is, therefore, lost in urine. Hyperchloremia and potassium loss because of aldosterone secretion finally results.

Manifestations include failure to thrive, refractory rickets, and, infrequently, nephrocalcinosis.

It may occur as an isolated condition, or secondary to Fanconi syndrome. This syndrome is characterized by glucosuria, phosphaturia, amino-aciduria, carnitinuria, and proximal RTA. Besides, the primary form, Fanconi syndrome may occur secondary to inherited (cystinosis, Lowe syndrome, galactosemia, hereditary fructose intolerance, Wilson disease, tyrosinemia, medullary cystic disease) or acquired disorders (heavy metals, expired tetracyclines, 6-mercaptopurine, nephrotic syndrome, interstitial nephritis, hyperparathyroidism).

Alkali, 10 to 15 mEq/kg/day (note the dose is much higher than that in distal RTA), along with potassium is needed to correct the acidosis.

Type IV (mineralocorticoid deficiency) It is the result of inadequate production or lowered distal tubular responsiveness to aldosterone. Hyperkalemic hyperchloremic acidosis that tends to reduce the urine pH to under 5.5 is the net outcome.

This variety of RTA may be secondary to adrenal disorders (Addison disease, congenital adrenal hyperplasia, primary hypoaldosteronism), hyporeninemic hypoaldosteronism (obstruction, pyelonephritis, interstitial nephritis, diabetes mellitus, nephrosclerosis), or pseudohypoaldosteronism. Obstructive uropathy is, undoubtedly, its most common cause.

Nephrogenic Diabetes Insipidus (NDI)

This condition is characterized by failure of the kidneys to respond to antidiuretic hormone (ADH) though the levels of this hormone are quite high.

Two varieties are recognized. In primary NDI, a rare disorder with usually X-linked recessive inheritance, the distal tubule is not able to respond to ADH. A dramatic history of polyuria and polydipsia in infancy with hypernatremic dehydration in infancy is classical in males with primary NDI. In females with primary NDI, manifestations are mild and may be detected later in life.

In secondary NDI, there may be diminution of hypertonic medullary gradient because of solute diuresis or failure of tubules to reabsorb sodium chloride and urea. It can also result from induced tubular unresponsiveness.

Treatment consists of provision of adequate fluid and calorie intake, reduction of sodium intake to reduce urinary solute load, and diuretic therapy (chlorthiazide 20 to 40 mg/kg/day in divided doses). Subjects with primary NDI not responding to this therapy should be administered indomethacin which acts by inhibiting prostaglandin synthesis.

Bartter Syndrome

This rare form of renal potassium wasting, presumably a primary defect in the ascending limb of the loop of Henle, is characterized by severe hypokalemia, excessive potassium excretion, normal blood pressure, vascular insensitivity to pressor agents, elevated plasma renin and aldosterone, and metabolic alkalosis.

Manifestations include failure to thrive, muscle weakness, polyuria, polydipsia, dehydration and

constipation. In older children, muscle cramps and carpopedal spasms may be additional features.

Therapy resolves round providing adequate nutrition and maintaining serum potassium level above 3.5 mEq/L. In case of failure of potassium therapy in as high a dose as 250 mEq/day, triamterene, 5 to 10 mg/kg/day, or indomethacin, 3 to 5 mg/kg/day, is indicated.

ACUTE RENAL FAILURE (ARF)

The condition refers to severe renal dysfunction, characterized by a sudden reduction of urine excretion to under 10 ml/kg of body weight, indicating marked oliguria or even anuria.

Manifestations resulting from overhydration, anemia, uremia, acidosis and hyperkalemia are generally present. The *oliguric phase* is followed within 7 to 10 days by *diuretic phase* in which urine flow rises and child's general condition improves. During the *recovery phase*, urinary excretion falls and renal function gradually returns to normal. Some cases may not show satisfactory improvement. They often pass on to *chronic renal failure*.

Etiology

Table 26.3 gives the list of important conditions that may lead to renal shutdown.

Table 26.3: Etiology of acute renal failure

Prerenal	Renal	Postrenal
Dehydration from severe vomiting, diarrhea or dysentery	Acute glomerulonephritis	Bladder-neck obstruction
	Hemolytic uremic syndrome	Urinary tract obstruction from other congenital lesions or pus collection
Diabetic acidosis Hypovolemia in nephrotic syndrome	Renal vein thrombosis DIC	
Burns, bleeding, shock, trauma, CCF	Acute tubular necrosis from toxins. Neoplasm	Sulfonamide crystals
Too little sodium in IV fluids	Drowning iatrogenic	

Investigations

The investigative and nursing measures, that are essential in the proper management of acute renal failure, are highlighted in Table 26.4.

Table 26.4: Vital investigative and nursing measures in acute renal shutdown

Oral intake	Blood pressure
Urinary output	Blood urea
Weight record	Electrolytes

Management

The sheet-anchor of management is the control of fluid and electrolyte balance. A strict intake and output chart is required to be maintained.

In a child with complete anuria, daily intake of fluids should be restricted to losses through perspiration, vomiting, stools and breathing. This may be given by mouth or intravenously. If IV isotonic saline or Ringer lactate is to be given, 20 to 30 ml/kg of body weight in one hour is the recommendation. Excessive intake of fluids is risky.

If the underlying cause of anuria is excessive blood loss or burns, a blood transfusion (10 to 20 ml/kg) is indicated.

In case oliguria/anuria continues, a rapid infusion of mannitol may be given. The recommended dose of mannitol is 0.2 to 0.5 g/kg of a 20% aqueous solution, administered intravenously during a 3 to 5 minutes interval. If a satisfactory response occurs (excretion of 6 to 10 ml/kg of urine in next 1 to 4 hours), a second dose of mannitol may be repeated. An important prerequisite for administration of mannitol is that the patient must be adequately hydrated before its infusion.

The response to mannitol is poor, a diuretic like frusemide may prove of value.

In case of hyperkalemia, any further administration of potassium should be avoided. To reduce the potassium level, the following measures may be helpful:

1. Administration of a *cation-exchange resin* in the sodium form. Resonium A in a dose of 1 mg/kg/day (in 2 divided doses) lowers serum potassium by 1 mEq/L.

2. For rapid control of fulminant hyperkalemia, administration of *glucose-calcium gluconate-insulin infusion* is indicated. Alternatively, hypertonic sodium lactate or bicarbonate solution, 3 mEq/kg, is a useful measure for transitory relief.
3. *Peritoneal dialysis* or *hemodialysis* is needed in case of persistent hyperkalemia not responding to the above treatment.

The additional indications of dialysis are progressive metabolic acidosis, rise in blood urea at a rate exceeding 100 mg% per 24 hours, congestive cardiac failure and further aggravation in clinical condition of the child.

Remember that dialysis must be initiated slowly. Or, else the patient may develop symptoms ranging from nausea and vomiting to severe headache and convulsions. The probable explanation is: rapid removal of urea from blood is far too much for the slow removal exercised by the brain and results in cerebral edema. This complication is called *dysequilibrium syndrome*. It is more often encountered with hemodialysis.

In case of hypocalcemia, 4 to 8 g/kg by mouth or smaller amounts intravenously of calcium gluconate should be administered. In order that this therapy proves effective, aluminium hydroxide gel, 1 to 2 teaspoonful 3 to 4 times daily, should be given. Also, care should be exercised to restrict phosphate-rich foods like milk. It is difficult to bring up serum calcium in the presence of hyperphosphatemia.

If remarkable acidosis coexists, it should be corrected with sodium lactate or bicarbonate.

Diet should be primarily in the form of carbohydrates and fat, providing at least 50-60 kcal/kg. Proteins should be restricted to 0.8-1 g in infants and 0.6-0.8 g/kg in children to cut down endogenous catabolism. The latter predisposes to hyperkalemia and azotemia. It is important to provide supplements of micronutrients.

In case anemia, hypertension and congestive cardiac failure (CCF) are coexisting, these should be adequately controlled.

While patient's acute problems are being tackled, efforts should also be directed at finding the etiologic factor responsible for the shutdown.

In order to minimize catabolism and azotemia, some authorities recommend anabolic steroid

therapy. In our experience, such a therapy should be restricted to cases of renal shutdown of long-standing duration.

Prognosis

Overall mortality is around 30%. Poor prognostic signs include associated sepsis, delayed referral and initiation of appropriate treatment, and cardiac, hepatic or respiratory failure.

CHRONIC RENAL FAILURE (CRF)

The term, *chronic renal failure*, refers to permanent, irre-versible and gross deterioration in renal function, finally leading to end-stage renal disease.

Etiology

Table 26.5 lists important causes of chronic renal failure. However, it must be emphasized that whereas anatomic abnormalities like hypoplasia, dysplasia, obstruction and malformations top the list before 5 years of age, acquired glomerular disease (glomerulonephritis, HUS), or hereditary disorders (Alport syndrome, cystic disease) dominate the scene in later years.

Table 26.5: Etiology of chronic renal failure

Glomerulonephritis
Primary
Secondary
SLE
Henoch-Schönlein purpura
Renal Infections
Pyelonephritis with or without reflux nephropathy
Tuberculosis
Obstructive nephropathy/uropathy
Posterior urethral valves
Bilateral calculi
Bilateral pelviureteric junction obstruction (stenosis)
Congenital Anomalies
Polycystic kidneys
Bilateral renal dysplasia
Storage Diseases
Amyloidosis
Tumors
Bilateral Wilms' tumor
Hereditary Nephropathies
Alport syndrome
Nephrophthosis

Clinical Features

Manifestations include increased thirst, frequent passage of urine, progressive anemia, hypertension, growth retardation, rickets, and bone pains. In late stage, acidotic breathing, anorexia, nausea, vomiting, muscular weakness, peripheral neuropathy, itching, purpura, cardiomyopathy and pericarditis are present. Superadded infection, as a result of defective granulocytic function and impaired cellular immune function, is frequent, and often contributes to terminal renal failure and mortality.

Treatment

Diet in CRF needs particular attention. The protein intake needs to be at least 1.5 g/kg/day (100 percent of RDA). It should be of highest biologic value, e.g. eggs, milk, meat, fish and fowl. Limiting protein intake to a very low level not only fails to stop progression of renal failure but also causes growth failure. Calorie intake should be 80-100 percent (or more in the event of existing growth deficit) of RDA. Low phosphate milk should be preferred. High potassium foods and excessive intake of sodium should be avoided. Supplementary vitamins (water soluble), calcium and zinc may be administered.

Water intake should be liberal, ensuring that dehydration is prevented at all costs. Else, the subject runs the risk of going into enhanced azotemia.

Acidosis with serum bicarbonate falling below 20 mEq/L occurs when GFR falls below 50 percent of normal needs to be treated with sodium bicarbonate tablets (2-3 mEq/kg/day, may be increased as required) to raise the serum bicarbonate level above 18-20 mEq/L.

Anemia with hemoglobin falling below 6 g/dl needs a packed red cell transfusion (10 ml/kg) cautiously. The new modality, recombinant *human erythropoietin* or synthetic erythropoietin has eliminated the need for repeated transfusions, thereby preventing such complications as iron overload, cytotoxic antibodies and superimposed infections.

By maintaining hemoglobin level, it improves fitness of the subject.

Erythropoietin is, however, very expensive and not yet freely available in developing countries. Its indication is a hematocrit under 0.27 or transfusion dependence. The dose is 50 units/kg/week (SC) in

single or two divided doses. If response is inadequate, dose is increased by 25 units/kg/week. Once target (hemoglobin 11 g/dl) is reached, dose is reduced by 12.5-25 units/kg/week.

Most common side effect of erythropoietin is hypertension followed by painful injection site, hyperphosphatemia, vasculare access thrombosis and influenza-like symptoms. Most frequent cause of unresponsiveness of the subject to it is iron-deficiency anemia followed by infection, aluminium toxicity, severe hypoparathyroidism, hemolysis and bone marrow dysplasia.

Hypertension needs to be appropriately treated to maintain diastolic values under 80 mm Hg. Acute hypertensive emergency is best handled with sublingual nifedipine or IV diazoxide, at times with frusemide. Therapy of sustained hypertension revolves round frusemide, propranolol, and hydralazine. Minoxidil and captopril should be reserved for resistant cases only.

Renal osteodystrophy needs to be managed with low phosphate diet supported by an antacid, calcium carbo-nsate. The latter not only binds phosphate in the GIT but also enhances its fecal excretion. Aluminium antacid must be avoided to safeguard against risk of aluminium poisoning. Supplementation with calcium corrects hypocalcemia which is usual in CRF.

Large amounts of vitamin D₃, 25,000 to 100,000 IU/day or calcitriol (1,25-dihydroxycholecalciferol), 15 ng/kg/day in two divided doses or 0.5-1.0 mcg thrice a day, which is many times more potent than vitamin D₃ are initially indicated in:

1. Persistent hypocalcemia despite appropriate corrective measures,
2. Osteodystrophy as confirmed by high serum alkaline phosphatase level and radiologic evidence of rickets. Following occurrence of healing of rickets, dose of vitamin D₃ is reduced.
3. Serum PTH over 2-3 times the normal.

Symptomatic therapy with antihistaminics is justified in the presence of itching, anorexia and vomiting in advanced CRF.

Infections, especially urinary tract infection, must be energetically treated with appropriate chemotherapy. Else, further deterioration in the patient's condition is bound to occur.

Drug dosage needs careful monitoring since, when given in normal recommended doses, these may cause toxicity in CRF.

Renal transplant becomes the final remedial therapy in end-stage renal disease/failure.

HEMOLYTIC-UREMIC SYNDROME (HUS)

This systemic disease, the most common cause of acute renal failure in young children, is characterized by a triad of microangiopathic hemolytic anemia, thrombocytopenia and acute renal failure. Its incidence is increasing.

Etiology

The exact etiology is not yet known. Most cases in India show association with acute shigellosis. Other bacterial pathogens incriminated in its etiology include *Salmonella*, *E. coli* (0157:H7), *Clostridia*, *Campylobacter*, *Yersinia* and *S. pneumoniae*. Viruses such as coxsackie, ECHO, influenza, varicella, Epstein-Barr, infectious mononucleosis, measles, mumps and polio are also blamed for its development. Remaining associations of HUS include oral contraceptive, mitomycin or cyclosporine A use, endotoxemia, SLE, malignant hypertension, preeclampsia, postpartum renal failure, radiation nephritis, and complement deficiency.

Role of genetic factors in etiology of HUS is unclear though the syndrome is known to occur in more than one member of a family.

It has been postulated that there may be absence of a plasma factor that stimulates endothelial cell prostacyclin production.

Pathogenesis

The endothelial cell injury constitutes the hallmark of HUS. The brunt of this injury falls chiefly on the kidneys. Vascular endothelial injury in the kidney causes localized clotting. The hemolytic anemia results from damage to the RBCs as they pass through the altered vasculature. Thrombocytopenia is the result of adhesion or destruction of platelets in renal microvasculature. There is, as a rule, no evidence of disseminated intravascular coagulation (DIC).

Pathology

The early alterations in glomeruli include thickening of capillary wall, narrowing of capillary lamina, and

widening of mesangium. Deposition of a granular amorphous material appears to be responsible for these changes. Cortical necrosis may also be observed as a result of fibrin thrombi.

In advanced cases, partial or total sclerosis of glomeruli and vascular occlusion are noteworthy features.

Clinical Features

HUS occurs mostly in infants and children under 4 years of age.

Onset is acute. Five to 10 days following an episode of gastroenteritis with often bloody diarrhea, or an upper respiratory infection, such manifestations as pallor, irritability, weakness, lethargy, and oliguria make their appearance. In addition, dehydration, edema, petechiae, hypertension and hepatosplenomegaly may be found on clinical examination. CNS involvement leads to progressive drowsiness and seizures.

Diagnosis

The triad of microangiopathic hemolytic anemia, thrombocytopenia, and acute renal failure preceded by bloody diarrhea by 5 to 10 days strongly suggests diagnosis of HUS.

Differential diagnosis is from other causes of acute renal failure, especially those with microangiopathic anemia such as lupus and malignant hypertension. An entity that may present with all the manifestations of HUS is bilateral renal vein thrombosis. A noteworthy distinguishing feature of this condition is remarkable enlargement of the kidneys.

Complications

These include gross anemia, acidosis, hyperkalemia, overhydration, CCF, hypertension and uremia.

Extrarenal complications include CNS manifestations like seizures and coma, colitis, diabetes mellitus and rhabdomyolysis.

Treatment

Aggressive therapy of acute renal failure leads to survival of almost 90% subjects with HUS. Various therapies like steroids, heparin, platelet inhibitors, fibrinolytic therapy, plasmapheresis, fresh frozen plasma, etc. have been tried but are of doubtful value.

Recently, gratifying results have been obtained with high dose intravenous immunoglobulin therapy (IVIg).

NEPHROTIC SYNDROME

Nephrotic syndrome is a common pediatric problem, characterized by massive hypoproteinemic edema, gross albuminuria and hypercholesterolemia (hyperlipidemia). Because of gross albuminuria, serum albumin is low. Blood pressure and blood urea are usually normal.

Etiopathogenesis

Two types are known:

- A. *Idiopathic* In childhood, the vast majority (90%) belongs to this category. It is regarded by many authorities as a sort of *autoimmune phenomenon*, especially since it responds well to immunosuppressive therapy. Among idiopathic cases, minimal change disease, mesangial proliferation and focal sclerosis are found in 85%, 5% and 10%, respectively.
- B. *Secondary* Unlike adults, children only occasionally suffer from this type. It is responsible for only 10% of overall nephrotic children. The disease in this case is usually mediated by some form of glomerulonephritis (the dominant being membranous and membranoproliferative forms). Its known causes are:

1. Chronic glomerulonephritis (e.g. anaphylactoid purpura)
 - Focal glomerulonephritis
 - Membranous glomerulonephritis
 - Membranoproliferative glomerulonephritis
 - Mesangial proliferative glomerulonephritis
 - a. with IgM deposition
 - b. with IgA-IgG deposition (Berger disease)
2. Diabetes mellitus
3. Renal vein thrombosis*
4. Systemic lupus erythematosus
5. Malignant hypertension

6. Amyloidosis
7. *P. malaria* infection
8. Henoch-Schönlein purpura
9. Syphilis
10. Hepatitis B
11. Infective endocarditis
12. Sickle-cell disease
13. Lymphomas
14. Varicella
15. Ventriculoatrial shunt infection
16. AIDS
17. *Drug toxicity* Mercurials, gold salts, uranium, penicillamine, trimethadione, penicillin hypersensitivity, captopril, heroin.
18. *Congenital* It is a serious condition associated with congenital anomalies of renal architecture. Death occurs in infancy, usually due to severe renal insufficiency or overwhelming infection. Nephrosis of congenital variety is, fortunately, rare.

About 80 to 85% of children with nephrotic syndrome are of "minimal lesion", or "corticosteroid-responsive" type. The term, "minimal change nephrotic syndrome" (MCNS) is currently considered most appropriate for this condition. The rest of the 15 to 20% cases of nephrotic syndrome are due to chronic glomerulonephritis and other renal diseases, including those secondary to systemic disorders.

Here, the description shall be limited to the common variety, i.e. supposedly autoimmune nephrotic syndrome.

Pathology

The essential lesion is the thickening of the footplate of the basement membrane. As a result, there is increased permeability of glomerulus to plasma proteins.

It is now convincingly demonstrated by immunodiffusion technique that proteins of low molecular weight are filtered by the glomeruli more easily than those of high molecular weight. Thus, in minimal lesion, only albumin is filtered. If, however, the damage to basement membrane is significant, it results in escape of large proteins such as globulins.

This may be interpreted to mean that severity of nephrotic syndrome can be judged from the *selective proteinuria* which is expressed as *selective permeability index*. In advanced cases, the index exceeds 0.2.

* Recently, reports have appeared suggesting that renal vein thrombosis may well be a consequence rather than a cause of nephrotic syndrome

Clinical Features

Most patients are between 1 to 5 years at the onset of nephrotic syndrome. The peak incidence occurs at 2 to 4 years. Male to female ratio is around 2:1.

The *onset* is usually gradual but may be acute in some cases. A previously well child begins to gain weight over a period of days to weeks. This may be accompanied by periorbital puffiness (Fig. 26.1). All this may be regarded by the parents as a sign of "health" until obvious swelling of the body results. In a well-developed case, the clinical picture is fairly consistent: a preschooler having massive anasarca (Fig. 26.2) involving the face, extremities, trunk, abdomen (ascites) and genitalia, especially marked scrotal edema almost resembling hydrocele (Fig. 26.3). At times, hydrothorax may be present. This as well as massive ascites may cause respiratory embarrassment. Also, waterlogging may cause edema of the gut and diarrhea. Some enlargement of the liver is usual.

Blood pressure may be slightly raised in an occasional case. Anemia may be associated. ESR is usually high. Urine output is reduced.

Superadded infections of respiratory tract, skin and peritoneum (peritonitis) occur due to reduction in immunoglobulins. Infection may sometimes act as a precipitating factor for the onset of nephrotic syndrome.



Fig. 26.1: Nephrotic syndrome, showing gross periorbital edema

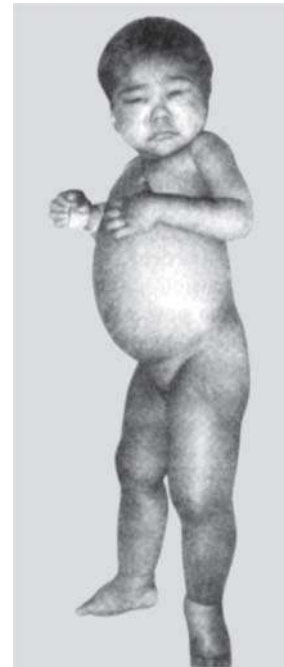

Fig. 26.2: Nephrotic syndrome, showing generalized edema



Fig. 26.3: Nephrotic syndrome: Note generalized edema, including hydrocele and involvement of the penis

Diagnosis

In most cases, clinical picture is so characteristic that diagnosis is quite clear. Occasionally, acute nephritis, kwashiorkor, anemia with hypoproteinemia or CCF may need to be differentiated.

Table 26.6 gives causes of proteinuria (other than nephrotic syndrome).

The following laboratory investigations are of value:

- i. *Urine* Gross proteinuria varying from 2 to 20 g/24 hours. Estimation of selective permeability

Table 26.6: Conditions other than nephrotic syndrome figuring in differential diagnosis of proteinuria

Benign
Febrile proteinuria (transient)
Exercise proteinuria (transient)
Postural (orthostatic) proteinuria
Pathologic
Tubular
Hereditary
Lowe syndrome
Cystinosis
Wilson disease
Proximal renal tubular acidosis
Acquired
Vitamin D intoxication
Analgesic abuse
Hypokalemia
Antibiotics
Metals (mercury, gold, lead)
Penicillamine
Cystic disease
Sarcoidosis
Acute tubular necrosis
Interstitial nephritis
Homograft rejection
Glomerular
Persistent asymptomatic proteinuria

index helps to find out how advanced the disease is. Transient slight hematuria may be present in some cases.

ii. *Blood* Hypoproteinemia, predominantly hypoalbuminemia (below 2.5 g), is remarkable. Serum albumin/globulin ratio is reversed. There is also hypogammaglobulinemia with an increase in the lipoproteins, i.e. alpha-2 and beta-globulins. Serum cholesterol and triglyceride levels show moderate to gross increase. Creatinine clearance is low. Blood urea nitrogen is often slightly increased. Hypomagnesemia is generally present.

ASO titer is low in a large majority of the cases. Serum IgG is raised, IgM low, and IgE raised.

Serum complement (C₃ and C₄) is normal.

iii. *Kidney biopsy* Percutaneous kidney biopsy is a useful measure for exact diagnosis as well as for assessment of prognosis. The procedure is detailed in Chapter 43.

Indications for doing biopsy are listed in Box 26.2.

Box 26.2: Indications for kidney biopsy**At Onset**

- Age < 1 year
- Gross hematuria, persistent microscopic hematuria or low serum C₃
- Sustained hypertension
- Renal failure not attributable to hypovolemia
- Suspected secondary causes of nephrotic syndrome

After Initial Treatment

- Proteinuria persisting despite 4-weeks of daily steroid therapy
- Before treatment with cyclosporin A or tacrolimus.

Treatment

Corticosteroids constitute the cornerstone of management. Various schedules have been employed. Generally, prednisolone, 2 mg/kg/day in divided doses, is most appropriate. Once edema has completely disappeared and the child has no albuminuria (this takes about 6 weeks), maintenance therapy can be given. For this purpose, prednisolone is given in a dose of 1.5 mg/kg/day as a single morning administration on every alternate day, for another 6 weeks. Then, it is tapered off, or abruptly stopped as per new trend.

Occasionally, a subject who responds to daily prednisolone initially may suffer from a relapse shortly after he is shifted to or after stopping alternate day therapy. This is termed "steroid dependence".

During steroid therapy, development of *Cushingoid facies* is frequent. A check on complications such as hypertension is essential. Remaining complications caused by prolonged steroid therapy include posterior subcapsular cataract, poor glucose tolerance, emotional problems and growth retardation (Table 26.7).

Table 26.7: Side effects of chronic steroid therapy

Electrolytes: Fluid retention (edema), hypokalemia

Disfiguring: Round facial contour, cervicodorsal hump (buffalo), anterocervical hump (Turkey), and pigmentation, hirsutism, baldness, kyphosis

Disquieting: Muscle wasting, hypertension, glycosuria, menstrual disturbances

Enjoyable: Euphoria, increased appetite

Disturbing: Insomnia, polyuria, headache, thinning of skin with development of striae and bruising, myopathy, poor wound healing

Alarming: Epigastric discomfort, intercurrent infections, osteoporosis, psychosis

Steroid therapy leads to necessary diuresis. But if it takes considerable time and there is much respiratory and cardiac embarrassment as a result of water-logging, large doses of diuretics like frusemide and ethacrynic acid may be given for a short period. During the diuretic phase, it is advisable to supplement the patient with potassium. Occasionally, tapping of the ascites and thoracentesis may be resorted to.

Antibiotics should be given in the presence of an infection. Their prophylactic use is not recommended.

Diet should be normal. There is no logic in limiting the protein intake. Salt and fluid restrictions are helpful when the child is in an edema phase.

Albumin infusion, 1 g/kg/day, in 8 to 12 hours, may be given as an adjunct in subjects with massive edema, particularly when accompanied by ascites and pleural effusion. It must always be followed by IV frusemide. Negative points of such a therapy are:

- Expensiveness
- Results are only transient
- Risk of hypertension, circulatory overload and pulmonary edema since edema fluid is mobilized into intravascular compartment. General measures include adequate rest, good nursing, training the child and/or family members regarding urine

testing for albumin, and reassurance to the parents. The pediatrician should educate the family about the important aspects of the disease which is known to have a prolonged course.

In case of a relapse (reappearance of edema and proteinuria), give prednisolone 2 mg/kg/day in 3 to 4 divided doses until proteinuria disappears (usually it does not take more than 2 weeks) followed by 1.5 mg/kg, as a single morning dose for another 4 weeks.

In case of frequent relapses (3 or more/year), child should be treated with long-term alternate day regimen for 9 to 12 months. Prednisolone dose should be smaller but enough to keep the child free of proteinuria as well as side-effects.

A short course (8 to 12 weeks) of cyclophosphamide, levamisole, tacrolimus, mycophenolate mofetil or cyclosporin therapy is indicated in subjects who show frequent relapses, who are steroid-dependent.

For steroid resistance, kidney biopsy dictates the therapeutic approach.

Algorithmic approaches to management of nephrotic syndrome and edema in nephrotic syndrome are given in Flow charts 26.1 and 26.2.

Finally, *renal transplantation* is indicated in end-stage renal failure because of steroid-resistant glomerulo-sclerosis (focal and segmental).

Flow chart 26.1: Algorithmic approach to management of patients with steroid sensitive nephrotic syndrome

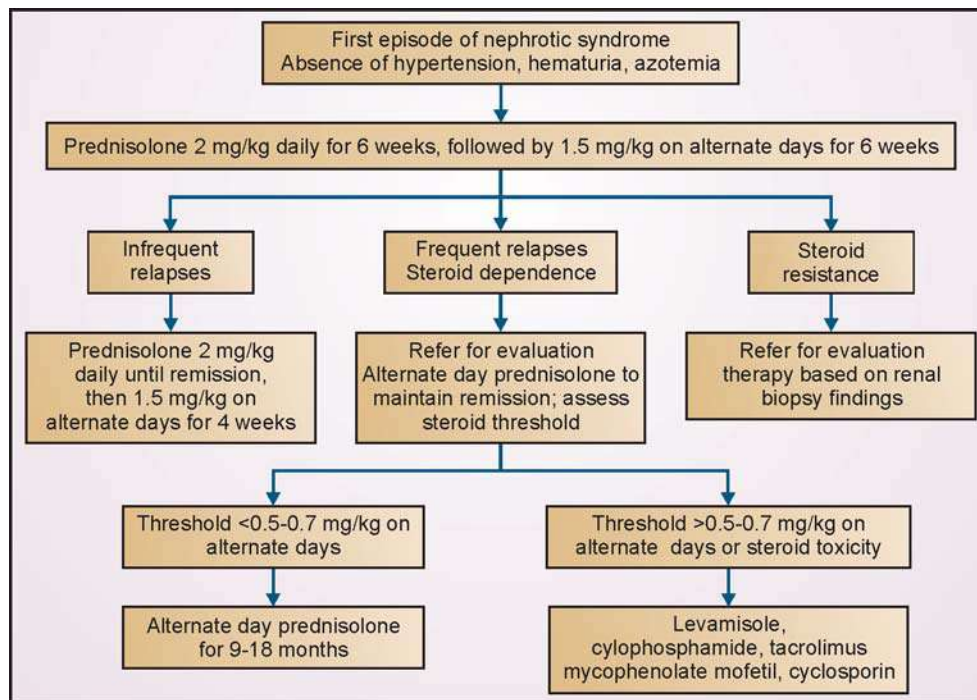

Flow chart 26.2: Algorithmic approach to management of edema in patients with nephrotic syndrome. Patients requiring high-dose frusemide or addition of other diuretics should be under close supervision, preferably in a hospital. Monitoring of serum electrolytes is necessary in all patients receiving diuretics. Patients showing hypokalemia require potassium supplements or co-administration of spironolactone. The medications are reduced stepwise once diuresis ensues

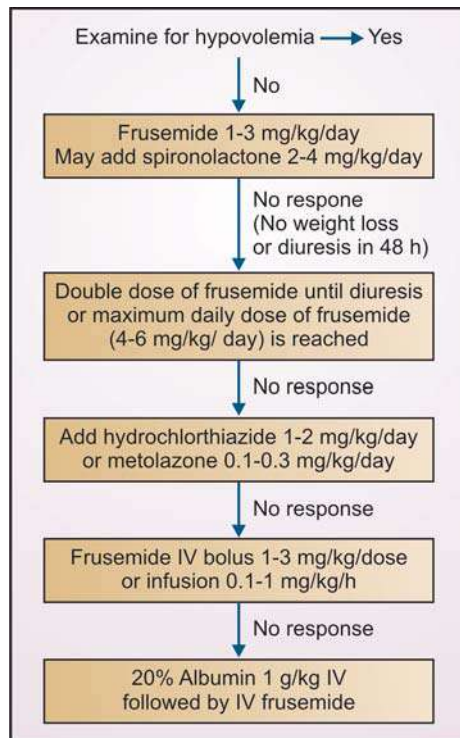

Complications

These include infections (peritonitis, UTI, pneumonia, meningitis, arthritis, osteomyelitis, cellulitis), thrombo-embolism, hypertension, hypovolemic shock and acute renal shutdown. The organisms responsible for infection are *Streptococcus pneumoniae* and gram-negative bacteria. Table 26.8 lists the factors contributing to enhanced incidence of infections in nephrotic syndrome.

Other problems include chronic calcium and vitamin D deficiency state with symptomatic hypocalcemia (tetany) and/or rickets/osteomalacia, and protein-energy malnutrition.

Growth retardation is a well-known accompaniment of prolonged steroid therapy. Nevertheless, "catchup" growth occurs when steroid therapy is discontinued.

Table 26.8: Factors contributing to high incidence of infection in nephrotic syndrome

- Reduced immunoglobulin levels
- Edema fluid acting as a culture medium
- Severe protein deficiency
- Reduced bactericidal activity of leukocytes
- Reduced perfusion of spleen from hypovolemia
- Loss in urine of a complement factor, *properdin* known to opsonize some bacteria
- Immunosuppressive therapy

Prognosis

With the steroid therapy, about 80% of the children recover. Around 10 to 15% go into chronic renal failure. Recurrent infections (peritonitis in particular) pose a significant problem. A cumulative mortality of 2 to 4% occurs in MCNS. The responsible factors usually are fulminant infection or abnormalities of coagulation or circulation.

That MCNS usually shows permanent remission or diminution in relapses during puberty is a myth.

HYPERTENSION

Acute hypertension is an important accompaniment of acute nephritis. It may also be associated with HUS, GBS, porphyria, lead poisoning, severe burns and CNS disorders. Chronic hypertension is more often than not asymptomatic in children. In essential hypertension, underlying cause is usually untraceable. The subject is generally an obese adolescent with family history of essential hypertension. Blood pressure rise is only mild to moderate. There is no particular damage to the target organ. For details, see Chapter 22 (Pediatric Cardiology).

RENAL STONE

See Chapter 40 (Pediatric Surgery).

PRIMARY BLADDER STONE

See Chapter 40 (Pediatric Surgery).

PHIMOSIS AND PARAPHIMOSIS

See Chapter 40 (Pediatric Surgery).

END-STAGE RENAL DISEASE (ESRD)

Though the exact magnitude of the problem of ESRD in India is not clear, the incidence in Western child population is 3/million/year.

The causes may be: (i) preventable (uncommon) usually diagnosed late, and (ii) unpreventable (common): congenital anomalies, renal dysplasia with obstructive uropathy, and various forms of persistent glomerulonephritis.

Modalities of treatment include chronic hemodialysis, chronic peritoneal dialysis—continuous ambulatory (CAPD) or continuous cycling (CCPD)—and renal transplantation, the last one being the treatment of choice.

CAPD consists of dialysis across the peritoneal membrane and removes surplus body water through an osmotic gradient caused by the glucose concentration in the dialysate and the wastes by diffusion from the peritoneal capillaries into the dialysate. Though less efficient than hemodialysis, *CAPD* provides satisfactory BUN and creatinine levels.

CCPD provides exchanges at night rather than during the day (as the patient is sleeping) by an automatic machine, thereby reducing the risk of parental fatigue and a burnout and allowing uninterrupted day of activities.

Renal transplant is the eventual goal in end-stage renal failure/disease. It may be carried out using cadaver or living-related donor as source for the organ graft. In sophisticated centers in the West, it has been carried out even in infants as small as weighing a sheer 5 kg. Success rate in children over 5 years of age is as high as in adults. Graft rejection is a major problem. With the employment of antilymphocytic globulin and cyclosporin A, and OKT 3, immunosuppressive management has considerably improved and acute graft rejection curtailed. Undoubtedly, further advances are warranted to prevent graft rejection and thus improve the success rate of renal transplant.

RENAL OSTEODYSTROPHY

(Renal or Uremic Rickets, Renal Dwarfism)

This term refers to skeletal changes that may develop in chronic renal disease characterized by chronic

glomerular failure with uremia, e.g., bilateral renal hypoplasia, hydronephrosis, polycystic disease, chronic pyelonephritis.

The bony changes are related to abnormalities in mineral and bone metabolism such as malabsorption of calcium, overactivity of parathyroid glands, cutaneous vascular and visceral calcification and poor production of biologically active vitamin D by the kidneys.

In preschool children with osteodystrophy, congenital malformations of the kidney are the leading cause.

Clinical Features

Manifestations include growth failure, dwarfism, wasting, muscle weakness, bone pain, bone deformities, slipped epiphyses, pathologic metaphyseal fractures, metastatic calcification, pruritus and mottling of skin around knees and thighs. Signs of rickets (say, widened epiphyses, frontal bossing, costochondral beading, genu varum and dental abnormalities) become evident in young children. Despite hypocalcemia, manifest tetany is rare.

Diagnosis

Biochemical investigations show high blood urea, low plasma CO₂ content (usually below 20 mmol/L), blood pH below 7.38, high alkaline phosphatase, and slightly low calcium but high phosphorus so that Ca P product is elevated.

Radiology shows periosteal erosions in middle and distal phalanges, distal clavicle and inner aspect of distal femur and proximal tibia.

Treatment

It consists in administering high doses of vitamin D, controlling hyperphosphatemia by administering aluminium carbonate gel, and supplying oral calcium. Undoubtedly, the basic etiologic condition also needs to be attended to for lasting results. Also see Chapter 14 (Vitamin Deficiencies).

FURTHER READING

Articles/Chapters

1. Agarwal I. Nephrotic syndrome. In Gupte S (Ed): *Recent Advances in Pediatrics*-14. New Delhi: Jaypee 2004;147.
2. Gupte S. *Differential Diagnosis in Pediatrics*, 5th edn. New Delhi: Jaypee 2008.
3. Gulati S. Hematuria. In Gupte S (Ed): *Recent Advances in Pediatrics* 17. New Delhi: Jaypee 2007.
4. Hari P, Mantan M, Bagga A. Urinary tract infection. In Gupte S (Ed): *Recent Advances in Pediatrics*- 14, New Delhi: Jaypee 2004;161.
5. Vijayakumar M, Prahalad N, Sharma NL, Nammalwar BR. Acute renal failure. In Gupte S (Ed): *Recent Advances in Pediatrics*-17. New Delhi: Jaypee 2007.

Books/Monographs

1. Gupte S, Srivastava RN, Kalia A (Eds). *Recent Advances in Pediatrics (Special Vol 15: Pediatric Nephrology)*. New Delhi: Jaypee 2005.
2. Indian Pediatrics Nephrology Group/Indian Academy of Pediatrics. Management of steroid-sensitive nephrotic syndrome: Revised guidelines *Indian Pediatr* 2008;45:203.
3. Srivastava RN, Bagga A. *Pediatric Nephrology*, 4th edn. New Delhi: Jaypee 2005.

CHAPTER



27

Pediatric Hematology

Jagdish Chandra, Suraj Gupte, Praveen C Sobti

DEVELOPMENTAL ASPECTS OF HEMATOPOIETIC SYSTEM

An extremely high rate of somatic growth in the fetus, relatively low oxygen tension and yet high metabolic rates of fetal tissues and sterile intra-amniotic environments necessitate the following vital features of fetal life:

- A remarkable increase in red cell mass with regulation of erythrocyte production by the hormone, *erythropoietin (Epo)*, which is produced in the liver of the fetus but by the kidney postnatally.
- An easy system of oxygen delivery in the form of fetal hemoglobin (Hb F) which is 90% at 6 months of gestation, and 70% at term. By 6-12 months postnatally only a trace is left (maximum 1-2%). Throughout fetal life and early childhood, an inverse relationship exists between HbF and HbA as also between alpha and beta chains (switch mechanism). HbA₂ is 1% at birth but by first birthday rises to 2.4-3.4%, the normal adult range. The ratio 30:1 of HbA: HbA₂ is maintained throughout life. High HbA₂ is found in beta-thalassemia trait and vitamin B₁₂ deficiency megaloblastic anemia. In iron-deficiency anemia, HbA₂ level is decreased.
- A low demand for neutrophils so much and so that neutrophils are virtually absent in the first and second trimesters fetus. Upregulation of neutrophil production is primarily controlled by granulocyte colony stimulating factor (G-CSF) both in fetus and postnatally. The G-CSF, the principle neutrophil regulatory growth factor, is relatively lacking until 22-24th weeks of gestation. Hence, there is no or very little granulocytogenesis. Neonates born

extremely preterm run the serious risk of bacterial infections.

Unlike the blood concentration of red cells and granulocytes, platelet concentration remains constant between 150,000-450,000/mm³ from 18 weeks of intrauterine life onward. These are produced following clonal maturation of committed progenitors, colony forming units-megakaryocytes (CFU-Meg) into megakaryoblasts and then megakaryocytes.

Table 27.1 gives the average hematologic values in pediatric subjects, including adolescents.

Table 27.1: Average hematologic values in neonates, infants, children and adolescents

Ages	Hb (g/dl)	PCV (%)	Retics (%)	TRCC (10 ¹² /l)	TLC (10 ⁹ /l)	PMN (%)
Neonates						
At birth	16.8	55	5.0	4.8	18.0	61
1-3 days	18.8	57	4.0	5.3	18.9	61
7 days	17.8	55	1.0	5.1	12.2	45
14 days	16.5	51	1.0	4.9	11.9	40
1 month	14.0	43	1.0	4.2	10.8	35
Infants						
3 months	11.5	35	1.0	3.8	10.8	36
6 months	11.5	35	1.0	3.8	11.8	32
1 year	12.0	36	1.0	4.5	11.5	31
Children						
2-6 years	12.5	37	1.0	4.6	9.0	42
6-12 years	13.5	40	1.0	4.6	8.5	55
Adolescents						
Boys	16.0	43	1.0	4.9	8.1	55
Girls	14.0	41	1.6	4.6	8.1	55

ANEMIAS

Anemia can be defined as reduction in hemoglobin concentration, hematocrit or red cell mass.

The cut-off point for defining anemia at different age groups is as follows:

Under 2 weeks	13 g/dl
Up to 6 months	9.5 g/dl
6 months to 6 years	11 g/dl
6 years to 14 years	12 g/dl
Above 14 years (Boys)	13 g/dl
Above 14 years (Girls)	12 g/dl
Pregnant Women/adolescents	11 g/dl

Grading

World Health Organization (WHO) grades anemia according to hemoglobin (Hb) level as per Table 27.2.

Table 27.2: WHO grading of anemia

Hb levels	Grades
Between 10 g/dl and cutoff point for age	Mild
Hb between 7 g/dl to 10 g/dl	Moderate
Hb under 7 g/dl	Severe

Table 27.3 gives clinical grading of anemia.

Table 26.3: Clinical grading of anemia

Clinical observation(s)	Grades
Pallor restricting itself to only conjunctiva and / or mucous membrane	Mild
Obvious skin pallor	Moderate
Palmar creases too are affected	Severe

CLASSIFICATION OF ANEMIAS

Anemia traditionally have been classified on the basis of etiology and RBC morphology. Table 27.4 describes a classification of anemia based on etiology and pathogenesis.

NUTRITIONAL ANEMIAS

In practice, nutritional anemia, particularly due to iron deficiency, virtually dominates the scene. Prevalence of nutritional anemia in Indian children is almost of epidemic proportion—a public health problem indeed!

Iron-Deficiency Anemia (IDA)

As emphasized earlier, iron-deficiency is the most common etiologic factor in anemias. It is especially common in infancy because both breast as well as cow milk do not provide the baby's needs for iron.

Table 27.4: Classification of anemia

- I. Disorders of impaired RBC Production
 - a. Deficiency anemia
 - i. Iron deficiency anemia
 - ii. Nutritional megaloblastic anemia (B₁₂ and folate deficiency)
 - iii. Mixed deficiency states (dimorphic anemia)
 - b. Bone marrow failure
 - i. Aplastic anemia — congenital and acquired (idiopathic and secondary)
 - ii. Selective red cell aplasia — (Congenital, Diamond-Blackfan anemia and acquired, e.g. transient erythroblastopenia of childhood).
 - iii. Marrow replacement — Myelofibrosis, osteopetrosis and malignancies.
 - c. Impaired erythropoietin production
 - i. Chronic renal failure
 - ii. Hypothyroidism and hypopituitarism
 - iii. Chronic malnutrition
 - d. Miscellaneous
 - i. Congenital dyserythropoietic anemias.
 - ii. Erythropoietic porphyria
- II. Disorders of increased RBC destruction
 - a. RBC membrane defect e.g. hereditary spherocytosis
 - b. Defects of hemoglobin synthesis
 - i. Quantitative (Thalassemias), e.g. beta, alpha, delta – beta thalassemias
 - ii. Qualitative (Hemoglobinopathies) e.g. Sickle cell disease, HbE disease etc.
 - iii. Combined — Quantitative and qualitative defects e.g. HbS – Beta thalassemia.
 - c. Defects of RBC enzymes — G-6-PD deficiency, pyruvate kinase deficiency
 - d. Acquired defects
 - i. Immune hemolysis — warm and cold antibody type, ABO and Rh-incompatibility.
 - ii. Infections — malaria, kala-azar, acute bacterial infections.

Secondly, poor iron stores in premature babies* predispose to further deficiency so that, at about third month (the time for maximal physiologic reduction of hemoglobin), there may be marked iron-deficiency anemia. Twins commonly become iron deficient. At times, only one of them may suffer. Preschool age and adolescence are particularly more vulnerable for IDA because of rapid somatic growth.

In older children, the causes include inadequate intake, malabsorption, infection, chronic blood loss (ancylostomiasis) and cow milk-protein (CMP) hyper-

* A healthy full-term baby has iron stores that are enough for first 6 months. This is said to be true even if the mother has had anemia during pregnancy. This has earned the fetus the title of a 'merciless parasite' who does not excuse the kind host either

sensitivity. Recently, convincing evidence has accumulated to the effect that iron-deficiency may *per se* cause an absorptive defect by damaging the small intestinal epithelium.

Rarely, in such errors of iron metabolism as sideroblastic anemia, idiopathic pulmonary hemosiderosis and congenital transferrin deficiency, iron gets stored in the body rather than being utilized for erythropoiesis.

Clinical Features

These include progressive pallor, irritability, anorexia, tiredness, weakness, failure to thrive, atrophy of tongue papillae, pica and koilonychia. Diarrhea is often present. At times, pseudotumor cerebri may occur. Occasionally, especially in severe anemia, spleen* is enlarged. Hemic murmur (soft systolic, having maximal intensity over the base and changing with position) is common. When anemia is severe, cardiomegaly may be present.

Though most children learn to adapt to anemia of prolonged duration, some may suffer from CCF, particularly in the presence of an added stress.

Recently, it has been demonstrated that frank iron-deficiency anemia causes *low infant behavior record (IBR)* as manifested by unhappiness, lack of cooperation and shorter attention span, as also *lower mental development index (MDI)*. Even subclinical iron-deficiency causes low MDI. Both IBR and MDI revert to normal following correction of iron-deficiency.

Diagnosis

Diagnosis of IDA rests upon demonstration of microcytic hypochromic anemia along with reduced body/serum iron. Peripheral smear examination shows anisopoikilocytosis (Fig. 27.1) and polychromasia. MCV, MCH and MCHC are reduced. RDW (Red Cell Distribution Width, a measure of variation of red cell size) is increased. There is mild reticulocytosis, leukocytosis and thrombocytosis. Serum iron is reduced (<30 mg/dl is considered diagnostic), so is serum ferritin (<10 ng/ml). Total iron binding capacity (TIBC) over 400 mg/dl strongly suggests IDA. Transferrin saturation is reduced (<12-14% in children and <16% in adolescents). Bone marrow is hypercellular with

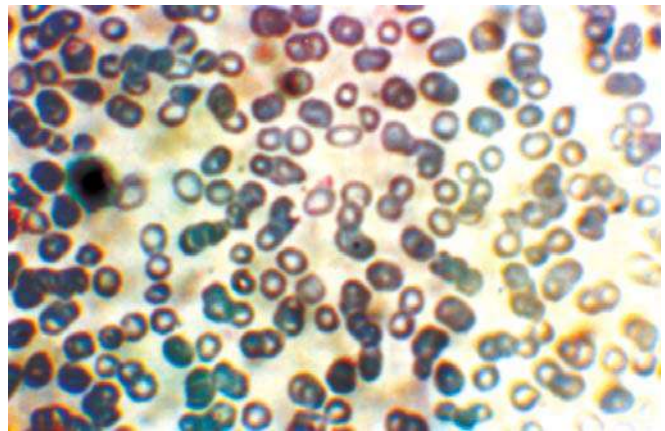

Fig. 27.1: Peripheral blood film showing microcytic-hypochromic picture with, anisocytosis and poikilocytosis in IDA

reduced iron stores but examination of bone marrow for diagnosis is not required.

On the basis of biochemical and hematological changes iron deficiency is graded into 3 Stages: Stage I — Depletion of iron stores (ferritin is decreased, transferrin saturation, serum iron and hemoglobin are normal, Stage II — Depletion of transport iron (transferrin saturation and serum iron also reduced, Hb is normal) and Stage III — State of IDA (frank features of IDA).

Differential Diagnosis

Iron deficiency anemia needs to be differentiated from anemia showing hypochromic microcytic picture, say lead poisoning, beta-thalassemia trait, thalassemia major, HBH disease (a type of alpha-thalassemia), and anemia accompanying chronic inflammations and infections.

Treatment

1. Specific treatment consists in replacing the iron deficiency with iron which may be administered orally or parenterally.

A. Oral therapy The dose of elemental iron is 3-6 mg/kg/day in 3 divided doses. Any iron can be given. But the most economic and most easily available one is the simple ferrous sulfate, containing 20% iron (Table 27.5) and available as 200 mg tablets. Oral iron, in any form, causes gastric irritation if given in excess dose. The side-effects of oral iron include nausea, vomiting, diarrhea, constipation, abdominal cramps, staining of teeth and tongue and discoloration of stools.

* We have often found some hepatomegaly as well though most textbooks do not mention this association

Table 27.5: Elemental iron content of various oral iron salts

Salt	Elemental iron (%)
Ferrous sulfate	20
Anhydrous ferrous sulfate	37
Ferrous sulfate (exsiccated)	30
Ferrous fumarate	33
Ferrous fructose	25
Ferrous succinate	23
Ferrous lactate	19
Ferrous carbonate	16
Ferric ammonium citrate	15
Ferrous gluconate	12
Colloidal iron	50

Even recommended dose may cause GIT disturbance in which case readjustment of the dose becomes essential. For optimal absorption, iron dose should be administered in between meals. Concurrent administration of vitamin C enhances its absorption whereas foods rich in phytates (cereals) and phosphates (milk) reduce it. The total duration of treatment varies from 3 to 6 months. Therapy must continue in the same dose for another 6 weeks after attainment of normal hemoglobin.

Hemoglobin rise following oral iron therapy is around 0.4 g/dl/day.

Factors contributing to poor response to oral iron include:

- Poor tolerance
- Subtherapeutic dose (< 3-6 mg/kg/day)
- Insufficient length of treatment
- Accompanying illness: Malabsorptive state, infection(s)
- Persistent bleeding (occult or frank)
- Poor compliance
- Iron administration soon after intake of milk (phosphates) or cereals (phytates)
- Incorrect diagnosis of IDA in thalassemia, lead poisoning or sideroblastic anemia.

B. Parenteral therapy It is indicated when one desires to cut down hospital stay, if oral medication is not feasible because of intolerance or presence of diarrheal disease, when gastrointestinal bleeding is likely to be worsened by oral iron therapy, and when there is a sufficient reason to believe that the patient is unlikely to regularly take his "pills". A small group of pediatricians prefers to initiate treatment with parenteral iron (a few injections only) and then put the patient on oral medication. They believe that such

a schedule helps in tiding over the initial "difficulties" in management.

Total dose is calculated by one of the formulas:

Dose of parenteral iron (intravenous infusion or intramuscular) is calculated as follows:

Iron required = $2.5 \times \text{body weight (kg)} \times \text{Hb deficit}$ (Hb deficit is the difference between measured and desired values of Hb).

An additional 20-30% of the calculated dose is included to replenish the stores.

Parenteral iron may be given intramuscularly or intravenously.

Intramuscular Administration: For this purpose iron-dextran complex (Imferon) and iron-sorbitol (Jectofer) are available. Daily dose of intramuscular injection should not exceed 5 mg/kg i.e 50 mg in infants and 100 mg in adolescents. The best site is upper and outer quadrant of thigh. To avoid repeat injection at the earlier prick, it should be given in Z fashion. The injection is given deep IM making sure that staining of skin doesn't occur. Adverse effects include local pain, fever, arthralgia, and lymphadenopathy,

Intravenous Administration: Only iron-dextran complex (Imferon) can be given by this route. After testing sensitivity with a small dose, the total dose infusion (TDI) is given in 250-500 ml of saline slowly over 6-8 hours. It is now only infrequently employed in view of the risk of shock and anaphylaxis.

Blood transfusion should be reserved for life-threatening situations when anemia is very severe and has associated symptoms warranting a rapid rise in hemoglobin level. If a decision to give blood has been taken, transfusion must be given slowly. Danger of CCF in such patients is really high (Table 27.6). A partial exchange transfusion is advisable in case of IDA accompanying CCF.

Table 27.6: High-risk factors in blood transfusion in severe anemia

- Age under 2 years: Poor cardiac tolerance may lead to cardiac complications especially with the presence of added stress in the form of pre-existing CCF, bronchopneumonia, congenital heart disease, edematous malnutrition, etc.
- Malnutrition: Myocardial weakness because of degenerative changes as in beriberi and circulatory overload as in kwashiorkor may lead to CCF.
- Impending CCF
- Acidosis
- Hypoglycemia
- Stored blood

Since iron is likely to cause proliferation of *E. coli*, it should be avoided during the course of an infection, especially in malnourished children.

Other measures include *digitalization* if the patient has CCF, adequate nutritional rehabilitation and adequate management of the underlying cause of anemia and associated illness. In our country, the worm infestations are invariably present and should be eradicated. Otherwise response to iron may be poor. Likewise, besides malnutrition, deficiencies of other hemopoietic factors such as folic acid and vitamin B₁₂ (which may introduce an element of macrocytosis/megaloblastosis in children with iron-deficiency anemia) should also receive attention.

Control Measures

- Neonates born preterm and LBW should receive oral iron by 2 weeks of age, provided that they are infection-free.
- Exclusive breastfeeding should be given for first 6 months.
- Complimentary foods rich in iron, say green-leafy vegetables, beans, pulses) should be initiated at 6 months of age since “exclusive milk” diet is likely to contribute to development of IDA in the infant in the second half of first year.
- Periodic treatment of intestinal parasitic infestations, especially hookworm infection, is quite helpful. Walking barefooted should be avoided.
- Iron supplements for susceptible infants and children and at puberty, especially in girls. This is usually achieved with iron tablets, syrup or drops. Alternative strategies include
 - Availability of iron-fortified salt (a government of India program) and food items
 - Availability of “Sprinkles” a novel form of microencapsulated iron which can be packaged in easy-to-use sachets for fortifying weaning foods at home. A low dose of 12.5 mg/day of elemental iron is not only quite effective but also better tolerated.

ANEMIA OF PROTEIN-ENERGY MALNUTRITION

As stated in Chapter 13 (Protein-energy Malnutrition), anemia is a common accompaniment of PEM. Generally, it is mild to moderate. But some of the

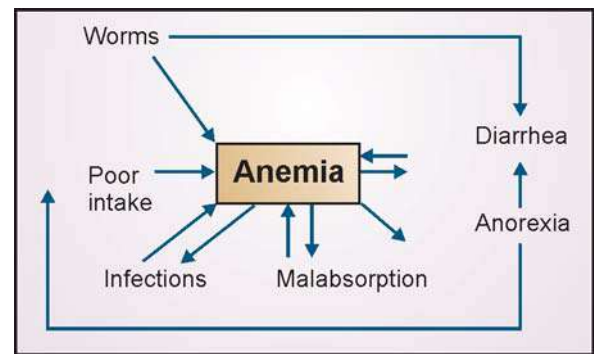

Fig. 27.2: Nutritional anemia cycle

children suffering from kwashiorkor have even severe anemia. It may be of variable morphology: hypochromic microcytic, macrocytic/megaloblastic or dimorphic-reflecting vitamin, mineral and protein deficiency. Whereas protein lack *per se* can cause anemia, in clinical practice anemia associated with PEM is seemingly *multifactorial in origin*. Besides, dietetic inadequacy of the nutrients needed for synthesis of hemoglobin, factors such as infections and infestations and coexisting absorptive dysfunction play significant role in its etiopathogenesis (Fig. 27.2). These factors need to be tackled if prompt response is the goal. Just providing nutrients does little good.

As regards the blood transfusion in treatment of such anemia, it is only infrequently required. Overenthusiasm in this behalf may mean losing the patient. The risk of CCF is particularly high. We have seldom resorted to transfusion unless anemia is very severe (2 or 3 g/dl hemoglobin). It is given very slowly, preferably after administering a modern fast-acting diuretic like frusemide (IV) to minimize chance of precipitating CCF.

PHYSIOLOGIC ANEMIA OF PREMATURITY

Normal decline in the Hb over first few weeks of life in term infants is known as “Physiologic Anemia of Infancy”. The fall in Hb is more in infants born premature. This exaggerated fall in Hb is termed as “Physiologic Anemia of Prematurity”. The rapidity and magnitude of fall of Hb vary with the gestational age of infants and their Hb levels at birth. In term infants Hb may fall to levels as low as 9-11 gm/dl by 8-12 weeks age while in premature babies, Hb as low as 8 gm/dl have been reported to occur by 4-8 weeks of age. This physiologic anemia is thought to result primarily from decrease in the red cell mass rather than hemodilution resulting from increasing plasma

volume. Minimum Hb levels in infants with comparatively lower Hb at birth are observed earlier than those with higher Hb though the lowest Hb levels observed are usually same.

Levels of erythropoietin (EPO) are low for the degree of anemia and the bone marrow is described as having relative erythroid hypoplasia. These observations plus normal EPO dose response curve observed in these infants suggest that inadequate EPO production is the major factor in the pathogenesis of anemia of prematurity.

On the basis of these, EPO therapy has been extensively used for treatment of these infants. Results in premature babies weighing over 1000 gms show decreased transfusion requirement but results in those weighing less than 1000 gms have not been consistent.

HYPOCHROMIC ANEMIAS REFRACTORY TO IRON

Pyridoxine (Vitamin B₆) Dependency Anemia

This hereditary disorder*, acquired as an X-linked recessive trait, is rare.

It is characterized by severe microcytic-hypochromic anemia, often early in infancy, and progressive hepatosplenomegaly. There is elevation of serum iron. Marrow shows erythroid hyperplasia with nucleated normoblasts containing iron inclusions, the so-called "sideroblasts" in abundance. There are abnormalities of tryptophan metabolism.

In a suspected case, the diagnosis should be confirmed by response of anemia to an adequate test dose (100 mg) administered parenterally.

Treatment consists in regular administration of vitamin B₆. Phlebotomy may be of added value in older children.

Sideroblastic Anemia

This, usually a familial disorder, is transmitted as an X-linked recessive disorder. The defect lies in biosynthesis of hemoglobin.

The anemia is characterized by iron resistance, hypochromia, elevated serum iron levels and overloaded iron stores. There are large number of sideroblasts (nucleated normoblasts containing iron

inclusions). Remember that low concentration of sideroblasts occurs even in normal individuals. In sideroblastic anemia, there is also remarkable increase in the number of erythrocytes containing iron inclusions, the so-called "siderocytes".

Diagnosis should be based on marrow, electrophoresis to demonstrate A₂ hemoglobin level, and therapeutic test with vitamin B₆ to differentiate it from other iron-resistant hypochromic anemias.

Anemia of Infection

Chronic infections such as rheumatic fever, rheumatoid arthritis, tuberculosis and malaria may have associated mild to moderate anemia, which is normochromic or slightly hypochromic.

The mechanism of development of such anemia is not clearly understood. The operative factors include a decrease in erythropoietin, a reticuloendothelial block and slight fall in red cell survival time.

Investigations show a normal marrow, presence of hemosiderin deposits and low serum iron and serum iron-binding capacity.

Treatment consists in giving blood transfusion, if anemia is severe, and control of the infection and inflammation.

Anemia of Lead Poisoning

It usually occurs in children suffering from "pica" involving ingestion of flakes of lead paint, artist's paint, etc. inhalation of fumes from batteries and from practice of employing "kajal" or "surma" containing black oxide of lead into the eyes.

Anemia of lead poisoning is hypochromic and microcytic and may be moderate to severe. A characteristic feature is the basophilic stippling of the red cells which helps to differentiate it from iron-deficiency anemia. The level of serum iron may be low, normal or high depending on the nutritional status. Sideroblasts are, however, always present in the marrow. Moderate reticulosis may occur.

Additional diagnostic studies include urine lead level above 80 mcg/d/24 hours, blood lead level above 80 mcg/dl, markedly elevated urinary coproporphyrins or red cell aminolevulinic acid dehydrase, long bone X-rays for lead line at the metaphyseal areas and abdominal X-ray for opaque flakes in the GIT.

Specific therapy consists in administering a combination of BAL and calcium EDTA for 2 days followed

* Pyridoxine-responsive sideroblastic anemia due to therapy with isoniazid in tuberculosis has also been described. It responds favorably to small doses of vitamin B₆ given orally

by penicillamine for 5 days. A high calcium high phosphorus diet and massive doses of vitamin D are of value in removing lead from blood and depositing it in the bones.

Severe anemia may warrant a packed cell transfusion. Iron should only be given after therapy with BAL is over.

Anemia of Thalassemia

This entity is discussed later in this chapter.

MEGALOBLASTIC ANEMIA

Megaloblastic anemias are designated so due to a characteristic morphologic change observed in the red cell precursors in these patients. At each stage of development, the red cell precursors are larger than their normoblastic counterpart, have altered DNA to RNA ratio, loose chromatin and asynchrony of nuclear and cytoplasmic maturation. Megaloblastic changes have long been recognized to occur due to deficiency of B₁₂ and folic acid and in certain inherited disorders involving both micronutrients. Clinical features and usually employed hematological tests do not distinguish whether folate or B₁₂ deficiency is the cause in a given case.

Etiology

It had been noted earlier that megaloblastic anemic during infancy and early childhood is more often due to folate deficiency and that seen among older children results from deficiency of B₁₂. However, recent evidence suggests that even B₁₂ deficiency is a frequent cause of megaloblastic anemia in infants and young children. Very often deficiency of both exists.

Deficiency of B₁₂

In children in developing countries, commonest cause of B₁₂ deficiency is nutritional. Children born to poor vegetarian mothers who are B₁₂ deficient have poor stores at birth. If these children are exclusively fed on breast milk (which in these mothers has poor vitamin B₁₂ levels) for unusually prolonged period, they develop B₁₂ deficiency. Among older children, diseases of small intestine resulting in malabsorption (tropical sprue), gastritis, gastrectomy, intrinsic factor deficiency (pernicious anemia) and fish tape worm (*Diphyllobothrium latum*) infestation are other causes.

Selective B₁₂ malabsorption (Imerstund-Grasbeck syndrome) is also described.

Folate Deficiency

Like B₁₂ deficiency, most common cause of folate deficiency is also nutritional. Maternal deficiency affecting fetus and infant is a frequent cause. Other causes include goat milk feeding, conditions with increased requirement (prematurity, chronic hemolytic anemias), malabsorptive states (tropical sprue and celiac disease), anticonvulsant therapy and anti-folate drug therapy. Inherited disorders like methylene tetrahydrofolate reductase deficiency are extremely rare.

Clinical Features

Other than pallor, children with megaloblastic anemia have apathy, anorexia, hypotonia and developmental retardation/regression. Hyperpigmentation of knuckles and terminal phalanges is a common finding described in patients from south-east Asian region. Glossitis with smooth, red, cracked tongue is characteristic. As described later, megaloblastic anemia is a panmyelopathy and hence fever due to infections resulting from neutropenia is quite common. Bleeding manifestations due to thrombocytopenia are observed in up to 25-30% cases. Mild to moderate enlargement of liver and spleen is seen. Presence of bleeding and/or hepatomegaly makes them resemble acute leukemias and bone marrow failure syndromes. Megaloblastic anemia is frequently seen in cases with infantile tremor syndromes. Neurological syndrome associated with B₁₂ deficiency (subacute combined degeneration of spinal cord) is infrequent in children.

Diagnosis

Hematological findings include low Hb and macrocytosis, anisocytosis, poikilocytosis and hypersegmented polymorphs on peripheral smear examination. RBC count is low. MCV is increased. Reticulocyte count is low. Deficiency of folate and B₁₂ does not only affect the erythropoiesis, myelopoiesis and thrombopoiesis are also affected. TLC is frequently reduced and so is platelet count. Pancytopenia has been seen in 40-70% cases of megaloblastic anemia. Bone marrow is hyperplastic with ineffective erythropoiesis and "megaloblastic changes" (Fig. 27.3), as described earlier.

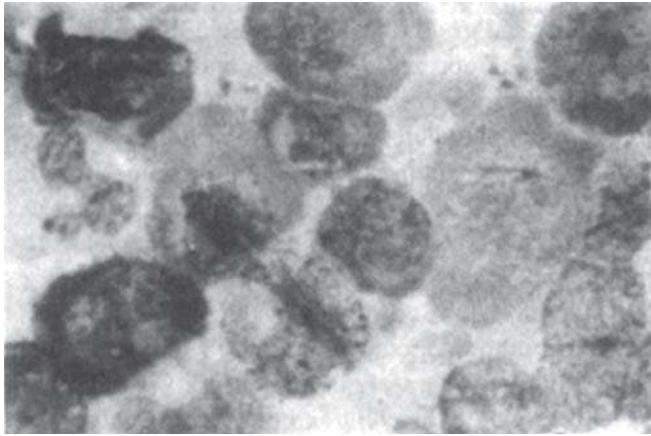

Fig. 27.3: Bone marrow showing characteristic megaloblasts in folic acid deficiency anemia

Serum levels of cobalamin and folate are reduced in respective deficiency.

FIGLU test for folate deficiency is currently rarely done.

Schilling test is performed to diagnose intrinsic factor deficiency.

Treatment

Specific treatment is administration of folate and B₁₂ in respective deficiency states. Folic acid in dose as small as 200-500 mcg/day may lead to adequate response but usually dose of 5 mg orally daily is administered as this is the size of tablet available which is cheap and harmless. Therapy for 6-8 weeks or longer is usually required.

B₁₂ deficiency is usually treated with 1000 mcg injection of B₁₂ given one or two times per week. Tremors may occur in some patients after administration of such a large dose. Hence, 250 mg weekly for infants and 500 mg weekly for older children is a better regimen. Therapy is continued for 6-8 weeks.

Concomitant administration of iron and correction of malnutrition is generally required.

Underlying cause too needs to be treated.

HEMOLYTIC ANEMIAS

By the term, *hemolytic anemias*, is meant the anemias resulting from increased red cell destruction in the presence of normal or increased erythropoiesis by the bone marrow.

CHARACTERISTICS OF HEMOLYSIS

Consequent upon shortened lifespan of red cells which normally spend 100 to 120 days in circulation, the following indirect indicators of hemolysis may be encountered:

1. Sustained reticulocytosis (over 2%) with an unchanging hemoglobin.
2. Lowering or reversal of myeloid-erythroid ratio from the normal ranges of 2 : 1 to 4 : 1.
3. Expansion of medullary spaces as a result of marrow hyperplasia, leading to remarkable radiologic changes, especially in skull, metacarpals and phalanges (only in chronic hemolysis).
4. Raised unconjugated (indirect) serum bilirubin with negligible or slight overt icterus.
5. Reduced level of serum hepatoglobin since it is utilized by free hemoglobin to form large hepatoglobin-hemoglobin complex which is cleared from circulation by reticuloendothelial activity.
6. Reduced serum hemopexin, another plasma protein that binds hemoglobin.
7. Increased level of free hemoglobin

Actual measurement of red cell survival can be directly carried out by isotopic techniques. These are, however, expensive and rarely warranted.

Classification

Broadly speaking, hemolytic anemias may be classified into two large groups:

- I. *Congenital or intracorpuscular defects* In this category, there is premature destruction resulting from intrinsic abnormalities of the red cells.
 - Structural defects:* Hereditary spherocytosis, hemolytic elliptocytosis, paroxysmal nocturnal hemoglobinuria.
 - Enzymatic defects:* G-6-PD deficiency defects in synthesis of hemoglobin: Thalassemia, sickle-cell anemia, HbC, D, E, etc, alone or in combination.
- II. *Acquired or extracorpuscular defects* In this category there is hemolysis caused by noxious extra-erythrocytic factors.
 - Immunologic disorders:* Rh and ABO hemolytic disease of the newborn, idiopathic autoimmune hemolytic anemia, lupus, lymphoma, drug-induced.
 - Nonimmunologic disorders* Infections like malaria, clostridia; Toxins like chemicals and drugs.

HEREDITARY SPHEROCYTOSIS (*Congenital Hemolytic Anemia, Congenital Acholuric Jaundice*)

Etiopathogenesis

In this usually autosomal dominant and occasionally autosomal recessive disorder, basic defect is deficiency of *spectrin*, a protein lattice that maintains the stability of the erythrocyte membrane shape. As a result, the red cells become spherical and voluminous. Repeated passage through the unfavorable environments in spleen (minute apertures between the splenic cords and sinuses offer resistance to the passage of spherocyte), cause sequestration and destruction of these cells.

Clinical Features

4

In infancy, including neonatal period, anemia and hyperbilirubinemia may be severe enough to warrant phototherapy and/or exchange transfusion. In later months of infancy, there is a tendency for reasonable compensation. Slight icterus is usually present. The spleen may be just palpable.

After infancy, the spleen is invariably palpably enlarged. Pigmentary gallstones may develop by 4 to 5 years but this event usually occurs in late childhood or adolescence. Chronic leg ulcers are infrequent in childhood. A viral infection may precipitate an *aplastic crisis* which should be considered a very serious complication.

Diagnosis

Anemia, hyperbilirubinemia and reticulocytosis establish presence of hemolysis. The peripheral smear shows the characteristic spherocytic cell which is smaller than the normal red cell and is devoid of central pallor. MCHC may be raised. Osmotic fragility is increased.

There are no abnormal hemoglobins and Coombs test is negative.

Treatment

Splenectomy, preferably carried out after 5 years of age, to safeguard against fulminant infections, leads to a clinical cure. The spherocytosis, no doubt, persists. Splenectomy also prevents occurrence of gallstones and aplastic crises, as also hemochromatosis and hepatic failure which may otherwise occur in adults.

Prior to splenectomy, the child must receive a polyvalent pneumococcal vaccine. Administration of prophylactic penicillin in the postsplenectomy period is considered appropriate.

THALASSEMIA

(*Cooley Anemia, Mediterranean Anemia*)

Whereas sickle-cell anemia and hereditary spherocytosis are uncommon in India, thalassemia occurs in a considerable proportion nearly all over the country. Carrier rate in different populations ranges from 2 to 6%. It is estimated that nearly 6000-8000 thalassemic children are born every year in India. Hence, there are over 100,000 thalassemics in the country. The disease is more common among Sindhis, Punjabis and Gujaratis. During the past three decades, we have cared for hundreds of children with this disease in Union Territory of Chandigarh, Himachal Pradesh and Jammu and Kashmir.

Table 27.7 gives incidence of beta-thalassemia in relation to major hemoglobinopathies in the world.

Table 27.7: Incidence of major hemoglobinopathies in the world

Overall	240,000/year
Beta thalassemia	20%
Beta thalassemia/HbS	1.6%
HbS	78%

Thalassemia was first described by Cooley in 1925 as "a hereditary hemolytic anemia with characteristic frog-like or mongoloid facies, skeletal changes and splenomegaly".

Etiopathogenesis

The basic defect is a hereditary inability to produce beta-chains (normal adult hemoglobin, Hb-A) which results in erythrocytes that are thin and have short lifespan. The result is hemolytic anemia with characteristic changes in blood and various organs. As a compensatory mechanism, increased production of fetal-hemoglobin* (Hb-F) occurs. In the peripheral blood, a large number of normoblasts, target cell and microcytic hypochromic erythrocytes are present. Reticulocyte count is increased.

* Fetal hemoglobin is composed of two alpha and two gamma chains. It is resistant to denaturation by alkali. This forms the basis for its quantitative measurement in the laboratory

Unless patient has iron deficiency because of some other factor(s), serum iron is normal or high. Bone marrow hyperplasia causes bony changes.

Severe form (*thalassemia major*) is associated with homozygous state. *Thalassemia minor* is mild and is associated with heterozygous state. *Thalassemia trait* is asymptomatic.

Clinical Features

The disease starts manifesting about 3 months of age with progressive pallor, growth failure, jaundice of varying degree and enlargement of liver and spleen. Recurrent respiratory infections are common. Lymphadenopathy may be present. Physical retardation of growth may be accompanied by hypogonadism.

The facial appearance is characteristic with frontal bossing, prominent maxilla (exposing the teeth), depressed bridge of nose, and malocclusion of teeth (Figs 27.4 and 27.5). This appearance is often referred to as *thalassemic* or *hemolytic facies*.

Increased pigmentation of the skin due to high level of melanin in the epithelium and hemosiderin in the dermis may occur.

By adolescence, the subject develops significant cardiomyopathy due to chronic anemia and progressive myocardial iron deposition as a result of increased iron turnover. Dysarrhythmias, atrioventricular blocks and other conduction disorders, pericarditis and even cardiac tamponade, CCF and ECG repolarization abnormalities may be encountered.

Diagnosis

Blood picture shows a microcytic hypochromic anemia (usually the hemoglobin between 4 to 9 g/dl range), anisocytosis, poikilocytosis, moderate basophilic stippling, nucleated and fragmented erythrocytes, *target cells*, large number of normoblasts and increased number of reticulocytes. Bone marrow shows erythroid hyperplasia. *Osmotic fragility* test reveals a reduced fragility (there is resistance to hemolysis in very dilute, i.e. hypotonic solution).

Fetal hemoglobin, measured by electrophoresis, exceeds 40% of the total*.

* It may be low in the presence of another hemoglobinopathy or in case of a recent blood transfusion



Fig. 27.4: Thalassemia major, showing hemolytic facies



Fig. 27.5: Thalassemia major. Note hemolytic facies and growth retardation. She had considerable splenohepatomegaly

Radiologic findings include thinning of the cortex, widening of the medulla (due to marrow hyperplasia) and coarsening of trabeculations in the long bones, metacarpals and metatarsals (Fig. 27.6). Skull shows the "hair-on-end" appearance due to vertical striations from widening of the diploic space and atrophy of the outer table of the skull (Fig. 27.7).

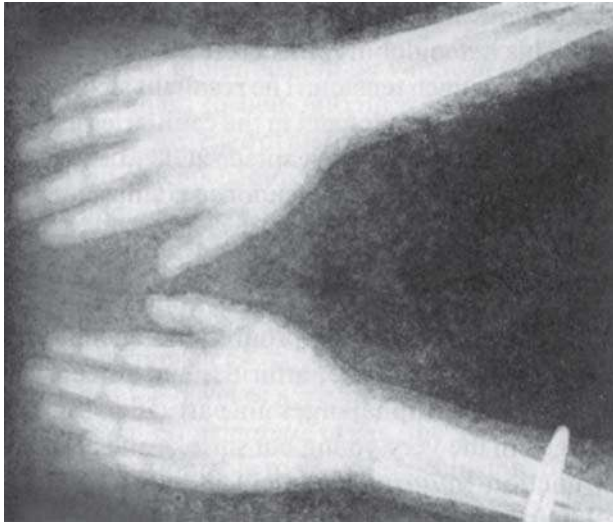

Fig. 27.6: X-ray hand and forearm showing thinning of the cortex and coarsening of trabeculae in thalassemia major

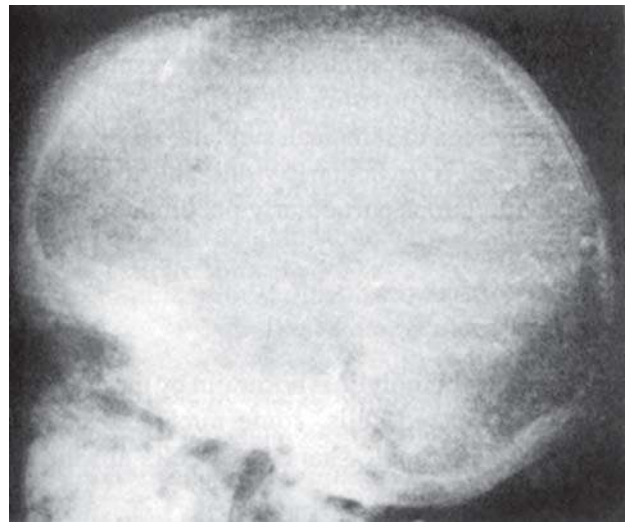

Fig. 27.7: X-ray skull showing "hair-on-end" sign in thalassemia major

4

Treatment

Allogenic bone marrow transplantation using a matched sibling donor is currently the curative treatment. This form of treatment is expensive and not easily available. In the absence of transplant, transfusion-chelation therapy is the only effective treatment.

Blood transfusion is given periodically at 3-5 weeks intervals maintaining hemoglobin at least 9 to 11 g/dl. Since *hemosiderosis and hemochromatosis* complicating repeated transfusions are *per se* serious problems, use of an iron-chelating agent is recommended.

Desferrioxamine (desferal) is the most effective iron chelator available. It is started after 15-20 transfusions and administered subcutaneously with an infusion pump 5 to 6 times every week. Dose is 30 to 70 mg/kg/day given over 8 hours. Dose needs to be tailored as per body iron overload and urinary excretion of iron. Concurrent administration of vitamin C, 100 mg/day, enhances excretion of iron by chelation. It also facilitates release of iron from ferritin. Maintaining serum ferritin below 1000 ng/ml is the aim. Unfortunately this treatment is expensive.

High-dose intravenous desferrioxamine therapy is indicated in subjects who are poor compliant, have been started on chelation late or have a iron-induced cardiac disease. This is far more expensive than the SC therapy.

Oral iron chelating agents have been found as an alternative to injectable iron chelating agent. The best

among the oral agents is deferiprone (DFP). It is administered in a dose of 75 to 100 mg/kg/day in 2 to 3 divided doses. Its side-effects include joint pains (arthropathy), nausea, vomiting, abdominal pain and agranulocytosis/pancytopenia.

Folic acid supplements are recommended. Particularly in those receiving sub-optimal transfusions therapy.

Human recombinant erythropoietin (r-epo) may improve the hemoglobin level in beta-thalassemia intermedia, thereby reducing or obviating the need for blood transfusion therapy.

Chemotherapeutic agents (5-azacytidine, hydroxyurea, myleran, butyrate salts) may be employed to stimulate gammaglobulin chain synthesis in thalassemia (as also in sickle cell anemia).

Splenectomy, benefits children who need very frequent blood transfusions or have very big spleen causing discomfort and/or hypersplenism.

Gene therapy consists of insertion of normal gene within stem cells of recipient. Even incomplete expression of transgene may lessen the severity of the disease significantly.

Prognosis

The outlook for life in thalassemia major has changed remarkably. Prognosis is clearly related to treatment in the form of high transfusion program and adequacy of chelation therapy. Patients are now surviving into 3rd and 4th decade and beyond and some have married and have children. Cardiac dysfunction

Table 27.8: Complications of thalassemia major and its treatment

- *Retardation of growth and development*
- *Transfusion transmitted infections:* Hepatitis B, C, and D, HIV
- *Chelation-related problems:* Desferrioxamine (DFX)-induced low body iron may cause serious neurotoxicity, pancytopenia, cartilage damage and linear growth retardation.
- *Endocrinopathies:* Iron overload, in the absence of chelation therapy, may cause several endocrinopathies, including diabetes mellitus, hypoparathyroidism and hypogonadism.

occurs even in those receiving adequate DFO chelation. For cardiac protection, chelation with deferiprone or combination of both drugs is superior.

Prognosis is clearly related to treatment in the form of high transfusion program and desferrioxamine (DFX) therapy. This therapy may also be responsible for hepatitis (preventable by hepatitis vaccine), failure of puberty attainment and hypoparathyroidism. Table 27.8 summarizes the various complications resulting from the thalassemia *per se* or its therapy.

Prevention and Counseling

Screening for thalassemia carrier is possible using NESTROF (naked eye single tube red cell osmotic fragility) test or various red cell indices (MCV, RBC count, Mentzer index, RDW etc). Confirmation of carrier status comes from demonstration of elevated HbA₂ on electrophoresis. There are 1 in 4 chances of the disease in the offsprings if both parents are carrier.

Antenatal diagnosis of thalassemia through analysis of fetal blood is now possible by fetoscopy at 18 to 20 weeks, aminocentesis at 17 weeks or chorionic villous sampling during first trimester, the later being the procedure of choice currently.

SICKLE CELL ANEMIA

The disease, until recently believed to be confined to the Negro race, is being increasingly detected in some parts of India such as Orissa, Maharashtra, among Bhanushalis, Budhists and neoBudhists.

Etiopathogenesis

Substitution of glutamic acid by valine at 6th position in the beta chain of hemoglobin results in HbS. It is caused by the presence of all the body hemoglobin in the form of Hb-S. This hemoglobin forms crescent-shaped crystals under low oxygen tension. The

resultant sickle-shaped erythrocytes tend to impact in the capillaries, and cause hemolysis, leading to infarcts in such organs as spleen, GIT, urinary tract, heart, lungs, brain, bones, tendons and muscles.

The sudden onset of severe hemolysis in sickle cell anemia is called *hemolytic crisis*, the sudden onset of symptoms attributable to vascular occlusion, the *vaso-occlusive crisis*.

Clinical Features

These include progressive anemia, slight icterus, fever, headache, arthritis, and osteopathy of metacarpals and phalanges in particular. Spleen is enlarged in the very young but shrinks as also ceases to function (*autosplenectomy*) in subsequent years following repeated thrombosis. Ulceration of skin overlying the lower limbs, nocturnal enuresis, growth retardation and folic acid deficiency may occur.

The patient is particularly vulnerable to superadded bacterial infections and anesthetic complications. An enhanced longing for common salt is striking.

A painful "crisis" may mimic a surgical abdominal emergency, rheumatic fever or CNS infection.

Poor red cell production together with rapid destruction may lead to "aplastic crisis".

Diagnosis

That anemia is hemolytic is borne out by the presence of normochromic red cells, some nucleated, and reticulocytosis. Sickle-shaped red cells are the most characteristic finding.

Resistance of red cells to osmotic lysis is increased.

Electrophoretic pattern shows 50 to 100% of hemoglobin as HbS and increased amount of HbF.

Treatment

Treatment of HbS disease consists of:

- Pneumococcal vaccination and penicillin prophylaxis which is started in all cases in early infancy.
- Vigorous treatment of infection.
- Analgesic therapy for pain crisis.
- Blood transfusion therapy in cases not able to maintain Hb otherwise.
- Therapy with hydroxyurea helps some patients by raising HbF and reducing the frequency and severity of crisis and transfusion requirement.
- Bone marrow transplantation is used with curative intent.

Prognosis

The younger the patient with severe manifestations, the poorer is the outlook. Intercurrent infections and sickle thrombi in vital organs are the common causes of death.

GLUCOSE-6-PHOSPHATE DEHYDROGENASE (G-6-PD) DEFICIENCY

This is a X-linked enzyme deficiency, most common among hereditary enzyme deficiencies, with incomplete dominant expression, mostly occurring in Mediterranean, African, Chinese and Indian stock. Overt clinical disease is encountered most often in males. Globally, it inflicts over 200 million individuals. Males are predominantly affected. The disease manifests clinically usually following exposure to certain agents (Table 27.9) and infection(s) and are related to development of intravascular hemolysis, increased plasma hemoglobin level and hemoglobinuria.

4

Table 27.9: Agents known to cause hemolysis in G-6-PD deficiency subjects

<i>Antimalarials:</i> Primaquine, quinine, mepacrine(quinacrine)
<i>Nitrofurans:</i> Nitrofurantoin, furazolidin, nitrofurazone
<i>Sulfas:</i> Sulfacetamide, sulfametghoxypyridazine, sulfisoxazole, acetylsulfanilamide
<i>Sulfones:</i> Diaminodiphenylsulfone (DDS). Sulfoxones, thiazol-sulfone
<i>Antipyretics:</i> Phenacetin, antipyrine (phenazone), aspirin, amidopyrine
<i>Antibiotics:</i> Nalidixic acid, gentamicin, kanamycin, cloxacillin, PAS, novobiocin, chloramphenicol
<i>Vitamins:</i> Vitamin K1 (water-solubleanalogue), large doses of vitamin C
<i>Miscellaneous:</i> Quinidine, BAL, methylene blue, probencid Naphthalene (moth balls), fava beans (broad beans)

Clinical Features

These vary with the type of deficiency. Three types are usually recognized.

Type 1 It manifests only on exposure to very powerful oxidant agents such as primaquine, sulfas, vitamin K (heavy doses), and naphthalene. The subject belonging to this type usually escapes developing neonatal hyperbilirubinemia.

Type 2 The moderate G-6-PD deficiency in this type manifests on exposure to fava beans, a large number of offending agents, and fulminant infection, especially viral hepatitis. In case of viral hepatitis, the individual, icterus becomes not only severer but also prolonged

with enhanced risk of developing hepatic encephalopathy. The hemolysis continues on continuing exposure to offending agent(s). Moreover, neonatal hyperbilirubinemia often occurs in such subjects.

Type 3 These subjects have a gross G-6-PD deficiency and develop manifestation (usually anemia) even without exposure to offending factors. A majority of these subjects develop severe neonatal hyperbilirubinemia. Exposure to known offending agents and superadded infection(s) is likely to cause severe hemolysis with hemoglobinuria.

Diagnosis

Screening tests for suspected G-6-PD deficiency include demonstration of Heinz bodies on supravital staining of RBCs, high plasma hemoglobin, raised serum bilirubin (unconjugated) and hemoglobin in urine. Estimation of G-6-PD enzyme level several weeks after the acute attack of hemolysis is a must for establishing the diagnosis.

Treatment

For severe hemoglobinuria, treatment is administration of sodium bicarbonate for alkalizing urine to safeguard against formation of hematin clots in the renal tubules and renal failure. For severe anemia, blood transfusion is warranted.

Prevention

It consists in avoiding known offending oxidants to known cases of G-6-PD deficiency and using them with caution in geographical areas or population with high prevalence of this deficiency.

PYRUVATE KINASE DEFICIENCY

This is an autosomal recessive enzymatic defect in which RBCs utilize less glucose than is expected of normal RBCs. As a result, there is lower liberation of ATP and leakage of potassium from the cells, leading to lowered life span of RBCs as also their functional defects.

Clinical Features

These include hemolytic anemia and hyperbilirubinemia in neonatal period and varying degree of pallor, icterus and splenomegaly later in life.

Besides routine evidence of hemolysis, these patients show autohemolysis that responds to ATP but not glucose. The diagnosis is established by remarkable reduction in pyruvate kinase level in RBCs.

Treatment

Severe neonatal hyperbilirubinemia usually warrants an exchange transfusion. In later life, treatment consists in giving repeated blood transfusions with supplements of folic acid and splenectomy in case of severe anemia.

AUTOIMMUNE HEMOLYTIC ANEMIA (AIHA)

In autoimmune hemolytic anemia, abnormal antibodies directed against red blood cells are produced endogenously by the patient's disordered immune system. Two types are recognized:

1. AIHA associated with warm antibodies, and
2. AIHA associated with cold antibodies.

AIHA Associated with Warm Antibodies

This may be primary or secondary. In the *primary* or the *idiopathic* form, no underlying cause is found. In the *secondary* or *symptomatic* form, an underlying disease process like lymphoma, SLE, or immunodeficiency is present. Drugs such as penicillin, cephalosporins, phenacetin, quinidine and methyl dopa that are known to produce AIHA may be considered under this very category. Occasionally, an immune thrombocytopenic purpura may coexist (Evans syndrome).

The antibodies involved in this type of AIHA belong to IgG. These antibodies act best at 37°C and hence called "warm".

Manifestations may be acute or chronic. In the acute transient type, usually occurring in infants and younger children and preceded by a respiratory tract infection, manifestations include prostration, pallor, jaundice, pyrexia, hemoglobinuria and gross splenomegaly. In the chronic form, hemolysis stretches over several months or years.

Laboratory findings include moderate to severe anemia, spherocytosis, polychromasia, fragmented red cells, marked reticulocytosis, and a strongly positive direct Coombs' test.

Treatment in profoundly anemic subjects is to give compatible (least positive Coombs test) blood transfusion (s).

In acute transient form, prednisolone, 2.5 mg/kg/day leads to full recovery within 3 months.

In chronic form, response to prednisolone is variable and inconsistent. Splenectomy is indicated when anemia continues to be severe after steroid therapy or when very large doses of steroids are needed to maintain a reasonable hemoglobin level. Immunosuppressive therapy, intravenous immunoglobulins, plasmapheresis, etc., deserve to be given a trial before splenectomy in refractory cases.

AIHA Associated with Cold Antibodies

In this AIHA, antibodies are more active at low body temperature and belong to IgM class, requiring complement for activity.

Cold agglutinin disease is characterized by an enormous increase in the cold antibodies following a viral infection or mycoplasmal pneumonia, causing severe episodes of intravascular hemolysis and hemoglobinuria when the patient is exposed to cold.

Paroxysmal cold hemoglobinuria is remarkable for a specific type of antibody. Designated "Donath-Landsteiner hemolysin", it has anti-P specificity. The condition is frequently associated with syphilis. Treatment is in the form of blood transfusions for severe anemia.

METHEMOGLOBINEMIA

This condition is characterized by chocolate-colored blood that fails to turn red even on aeration because of hemoglobin M. It may exist as an autosomal dominant inherited disorder of hemoglobin M when the subject is cyanosed since birth or as an inherited disorder of RBC enzymes, *methemoglobin reductase*, deficiency. In the latter situation, methemoglobinemia follows exposure to strong oxidants like analgesics, anesthetics, aniline dyes, antimalarials, nitrites, sulfas, vitamin K analogue and naphthalene.

Diagnosis is confirmed by spectrophotometry of hemoglobin electrophoresis at pH 7.

Prevention is by avoiding exposure to known offending agents.

Treatment is in the form of methylene blue, IV followed by oral, or vitamin C over a prolonged period.

APLASTIC ANEMIA

Bone marrow depression causing involvement of all the blood elements is called aplastic anemia or simply

pancytopenia. Involvement of only red cells is called the hypoplastic anemia, of granulocytes the agranulocytosis, and of platelets the thrombocytopenia.

Types

1. *Congenital (constitutional) aplastic anemia* may be:
 - *Fanconi type* (multiple congenital anomalies such as microcephaly, mental retardation, microphthalmia, squint, nystagmus, short stature, hypogonadism, defects of thumb and radius, brown pigmentation of the skin, dextrocardia and renal abnormalities). Diagnosis is confirmed by induced chromosomal breakage test (diepoxybutane/mitomycin C test). While 90% develop aplastic anemia, 10% present with other malignancies including acute myeloid leukemia (AML). Registry for Fanconi Anemia in India (REFAIN), based in Chennai, have over the past 15 years identified nearly 150 children with FA, mostly from South India.
 - *Blackfan Diamond syndrome or constitutional pure red cell anemia*.
 - Schwachman Diamond syndrome (exocrine pancreatic insufficiency).
 - TAR syndrome (thrombocytopenia, absent radii syndrome).
 - Dyskeratosis congenita (reticular skin pigmentation, mucosal leukoplakia, nail dystrophy, vulnerability to fractures).
2. *Acquired aplastic anemia* may result from viral, bacterial or parasitic infections (HIV, HB, EBV), infiltration of marrow by malignant tissue as in leukemia, Niemann-Pick and Gaucher diseases, or osteopetrosis (marble bone disease), irradiation, from chemicals and drugs such as chloramphenicol, antimetabolites, phenylbutazone, etc., and immune-mediated stem cell loss.

Management consists in stopping exposure to the possible cause, giving frequent blood transfusions and administering androgenic anabolic steroids as such or together with corticosteroids. Antibiotic cover is recommended.

Treatment

From the management point of view, acquired aplastic anemia is graded according to severity. Presence of

two of the following peripheral blood criteria – (i) Corrected reticulocyte count less than one per cent, (ii) Absolute neutrophil count less than $500/\text{mm}^3$ and (iii) Platelet count less than $20,000/\text{mm}^3$ and presence of hypoplastic or aplastic bone marrow puts the disease in category of severe aplastic anemia (SSA). Cases with absolute neutrophil count less than $200/\text{mm}^5$ are labeled as having very severe aplastic anemia (VSAA). This classification is useful for prognosis also.

For SAA and VSAA the treatment of choice is allogeneic bone marrow transplantation (BMT). In the absence of BMT intensive immunotherapy is used with anti-lymphocyte or anti-thymocyte globulin, cyclosporin with or without prednisolone. Monotherapy with cyclosporin or methylprednisolone are other options. Fanconi's anemia responds to androgen therapy.

Till the time patients respond to therapy, control of anemia and bleeding is required with transfusions of packed RBC or platelets. Infections need to be treated with appropriate antibiotics.

MECHANISM OF COAGULATION (HEMOSTASIS)

Hemostasis involves local reactions of blood vessels, multiple activities of the platelets, interaction of coagulation factors, inhibitors and fibrinolytic proteins circulating in the blood. It plays a vital role in maintaining a dynamic equilibrium between fluidity and coagulation so that neither excessive bleeding nor thrombosis occurs spontaneously or after a minor trauma.

Hemostatic mechanism may be primary or secondary. The former relates to vascular response and platelet plug formation, and the latter to the formation of a stable fibrin clot (Fig. 27.8).

Coagulation has three phases. In phase I, there is formation of thromboplastin by the interaction of certain coagulation factors, phospholipids and tissue juice containing tissue factor. Phase II involves conversion of prothrombin (factor II) to thrombin (factor II a). In phase III, thrombin converts soluble fibrinogen to fibrin.

Disordered coagulation causes a number of disorders (Table 27.10).

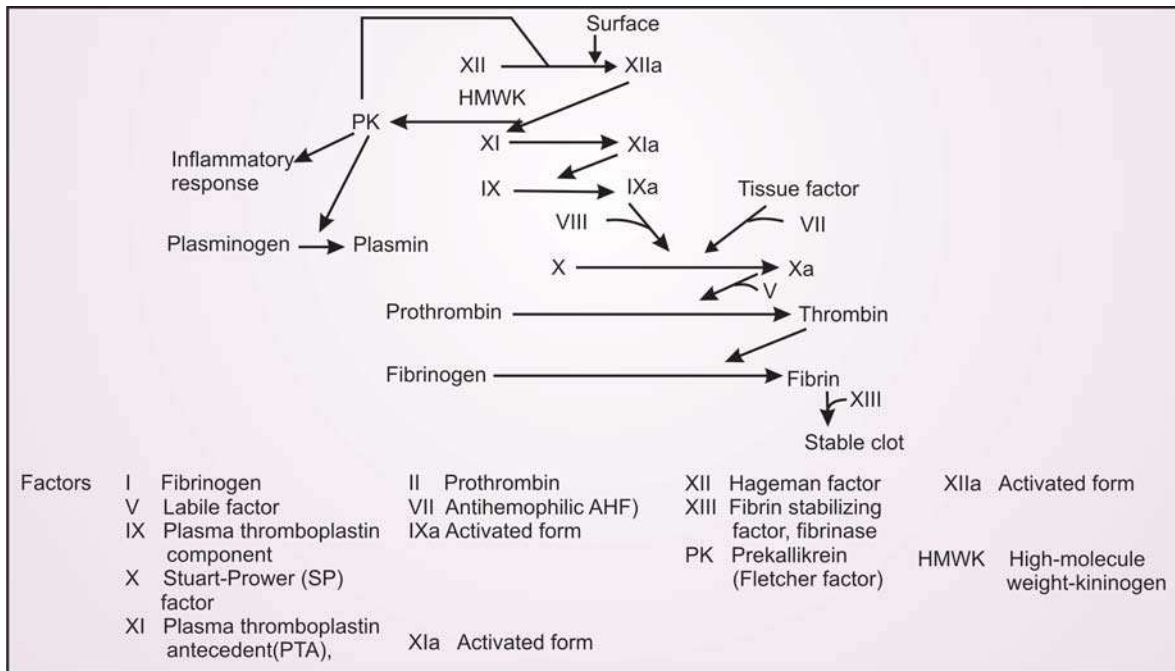

Fig. 27.8: Schematic representation of mechanism of coagulation

Table 27.10: Classification of coagulation disorders

Congenital Disorder

Phase I disorders Factor VIII deficiency (classical hemophilia, hemophilia A), Factor IX deficiency (Christmas disease hemophilia B), Factor XI deficiency (hemophilia C), Factor XII deficiency (Hageman factor deficiency), Von Willebrand disease (vascular hemophilia)

Phase II disorders Deficiency of a factor in prothrombin complex (factors II, V, VII and X)

Phase III disorders Congenital afibrinogenemia, Congenital dysfibrinogenemia

Factor XII deficiency (fibrin-stabilizing factor deficiency)

Acquired Disorder

Vitamin K deficiency Hemorrhagic disease of the newborn
Postneonatal vitamin K deficiency (late hemorrhagic disease)

Liver disease

Deficiency of all factors except factor VIII, DIC, Hyperfibrinolysis
Inhibitors

Circulating anticoagulants in SLE, lymphoma, penicillin or other drug reactions. DIC Septic shock, etc.

APPROACH TO A CHILD WITH BLEEDING/HEMOSTATIC DISORDER

History and Physical Examination

The enquiry must aim at determining if the defect is congenital (inherited) or acquired, and basically a coagulation or a bleeding disorder.

Attempt to determine the site(s) of bleeding, its severity, its duration, and the age of onset, whether spontaneous or precipitated by some factor, the experience with prior surgical procedure and trauma, family history, drug history, and, in girls, the menstrual history.

Physical examination should determine whether the bleeding is petechiae, ecchymosis, hematomas, hemarthrosis, or mucosa bleeding. The evidence of a primary systemic disease must be sought.

After the thorough history and physical examination, some provisional impression should be formed based on the clues thus provided. For instance:

- Development of petechiae or ecchymosis spontaneously (without a precipitating factor such as trauma) points to a bleeding disorder (purpura).
- Bleeding from umbilicus, if prolonged and occurring in a neonate, points to congenital type of plasma clotting factor disorders. Purpura, as a rule, manifests later in life.
- Availability of a positive family history of bleeding disorder usually points to existence of a plasma coagulation disorder.
- Deep bleeding into joints and muscles, diffuse spreading ecchymosis and hematomas suggest disorder of coagulation system.
- Mucosal bleeding (epistaxis, hematuria, menorrhagia, GIT bleed), petechiae in skin and

mucous membrane and ecchymotic lesions that are small and multiple point to purpura.

Investigations

Initial investigations should include prothrombin time, partial thromboplastin time and platelet count.

Complete blood count (CBC), including TLC, to exclude sepsis.

Blood smear to exclude DIC

Prothrombin time (PT), the time taken for plasma to clot following addition of exogenous thromboplastin (tissue factor) and calcium, varies from 11.5 to 14 seconds. A prolonged PT suggests a deficiency of factors II, V, VII and/or X.

Activated partial thromboplastin time (APTT), time needed for clotting of plasma (that has been activated by incubation with an inert activator such as ground glass ellagic acid or kaolin) on addition of calcium of platelets, varies from 25 to 40 seconds. This test evaluates the adequacy of factors VIII, IX, XI, XII.

In case both PT and PTT are prolonged, one should consider vitamin K deficiency, advanced liver disease and congenital deficiency of factors V and X.

Platelet count is essential in the evaluation of a child with bleeding disorder. A count of less than 20,000/cmm causes considerable bleeding. Thrombocytopenia is the most common cause of a primary hemostatic defect with overt bleeding.

Bleeding time is considered to be the best test for evaluating the vascular and the platelet phases of hemostasis. Normal bleeding time varies between 4 to 8 minutes (Table 27.11).

There is an inverse relationship between the BT and the platelet count. In other words, lower the platelet count, more prolonged the BT is likely to be.

A high BT with reduced platelet count suggests idiopathic thrombocytopenic purpura or purpura secondary to bone marrow aplasia or leukemia. A high

BT in the presence of normal platelet count points to anaphylactoid purpura or platelet dysfunction.

Mixing study consists in adding normal plasma to the plasma of the patient. If the PTT on the mixture is normal, it means that the patient's abnormal PTT stands corrected and the deficiency state is present. This points to a deficiency of VIII, IX, or XI. If the study fails to correct the defect, an inhibitor against factors VIII, IX or XI must be suspected.

Thrombin time, the time needed for plasma to clot after the addition of bovine or human thrombin (factor IIa), varies from 15 to 20 seconds. It is prolonged in hypofibrinogenemia, dysfibrinogenemia, and heparin contamination.

d-Dimer assays is now considered superior to fibrin split products (FSP) assays for measuring degradation products of fibrin found in the plasma in DIC and liver disease. Levels (normal < 0.5 mg/ml) are also raised in DIC, deep vein thrombosis and pulmonary embolism.

Apt test is employed to exclude maternal blood in a bleeding neonate.

Other tests include euglobulin clot lysis time (ECLT), assays for plasminogen, plasminogen activators, and inhibitors, and immunologic assays for fibrin split products.

According to current recommendations, the previously used tests such as tourniquet test, prothrombin consumption time and thromboplastin generation test lack specificity and sensitivity or happen to be cumbersome and difficult to interpret.

Table 27.12 lists the conditions in which CT and BT are prolonged.

DISSEMINATED INTRAVASCULAR COAGULATION (DIC)

DIC syndrome is characterized by consumption of certain coagulation factors (usually factors II, V and

Table 27.11: Situations in which clotting time and bleeding time are prolonged

<i>Prolonged CT</i>	
With high PT	Factor VII deficiency
With high APTT	Factor VIII, IX, XI and XII deficiency, von Willebrand's disease
With high PT and APTT	Vitamin K deficiency, advanced liver disease, DIC, factors V,X, fibrinogen deficiency.
<i>Prolonged BT</i>	
With low platelet count	ITP, drug-induced purpura, leukemia or bone marrow.
With normal platelet count	Henoch-Schoenlein purpura

Table 27.12: Etiology of disseminated intravascular coagulation (DIC) syndrome

Acute DIC	Chronic DIC	Neonatal DIC
Infections <ul style="list-style-type: none"> • Bacterial <ul style="list-style-type: none"> - Gram-negative septicemia - Gram-positive septicemia • Viral • Rickettsial • Fungal • Protozoal <ul style="list-style-type: none"> - <i>Pl. falciparum</i> malaria 	Malignancies <ul style="list-style-type: none"> • Monocytic leukemias • Disseminated neuroblastoma Cardiovascular disorders <ul style="list-style-type: none"> • Shock • Cyanotic congenital heart diseases • Giant hemangiomas Hemolytic anemias <ul style="list-style-type: none"> • Thalassemia major • Sickle-cell anemia Collagen vascular disease <ul style="list-style-type: none"> • SLE • Henoch-Schoenlein purpura • Polyarteritis nodosa 	Asphyxia Hypothermia Shock
Trauma <ul style="list-style-type: none"> • Crush injury • Burns • Major surgery 		
Miscellaneous <ul style="list-style-type: none"> Snake bite Acute hepatic failure Hemolytic-uremic syndrome Mismatched blood transfusion Acute promyelocytic leukemia 		

VIII), leading to widespread intravascular deposition of fibrin, bleeding from multiple sites and hemolytic anemia.

Etiopathogenesis

Several pathologic processes, including hypoxia, acido-sis, tissue necrosis, endothelial damage and shock, trigger DIC. Understandably, a large number of diseases may be accompanied by DIC (Table 27.12).

Nevertheless, gram-negative septicemia is the most common followed by gram-positive septicemia.

The process involved in development of DIC is depicted in Figure 27.9. One or more of such factors as hypoxia, acidosis, tissue necrosis, shock, and endothelial damage trigger intravascular activation of the clotting factors. The intravascular coagulation is followed by consumption of coagulation factors, leading to reduction in levels of factor I (fibrinogen), factor VII and platelet count. The formation of fibrin causes vascular occlusion and blockade of reticuloendothelial system. The activators released from damaged endothelium, platelets and leukocytes activate plasminogen. The latter is also activated directly by factor XII and thrombin.

The enhanced fibrinolytic activity leads to production and accumulation of massive fibrinogen degradation products (FDP) which result in platelet dysfunction. This prevents transformation of

fibrinogen to fibrin, thereby further worsening bleeding. Remember, the neonate is more vulnerable to develop acute DIC.

Clinical Features

In addition to the manifestations of the causative condition/disease *per se*, the hallmark of clinical picture is constituted by a generalized bleeding diathesis. To begin with, bleeding occurs from sites of venipuncture or surgical incision. This is followed by widespread ecchymosis, petechiae, epistaxis, subconjunctival hemorrhages, hematuria, etc.

Microvascular thrombi may cause infarction of massive areas of skin, subcutaneous tissue and many organs. End-organ damage may result in intracranial bleed, pulmonary edema and acute respiratory distress syndrome, acute renal failure, peripheral cyanosis and even gangrene. Shock and severe metabolic derangements may well be secondary to DIC as also the primary disease *per se*. Purpura fulminans may occur because of wide-spread thrombotic occlusion of dermal vessels, leading to sharply demarcated large patches of ecchymoses that may worsen to develop skin infarction. Profound anemia as a result of hemolysis develops rapidly.

In case of chronic DIC, symptoms of primary disease rather than those because of DIC dominate the scenario. Prominent DIC symptoms are subtle and

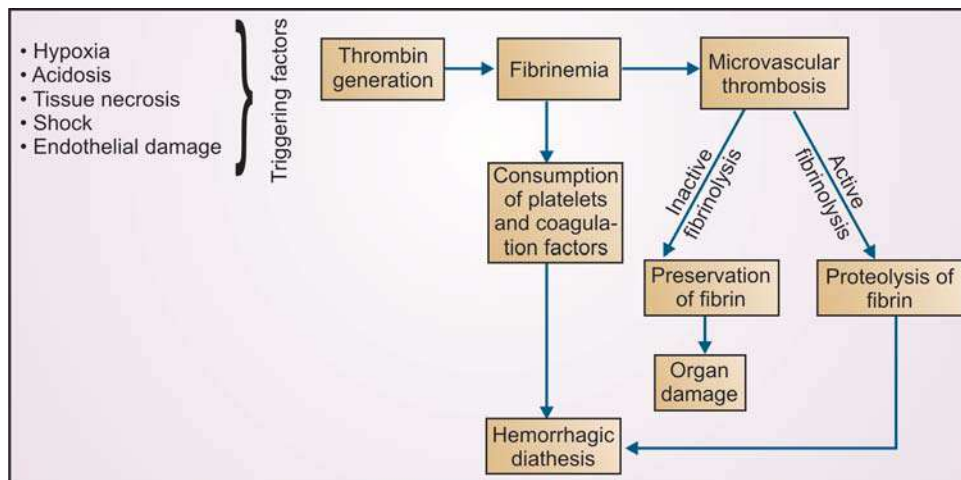

Fig. 27.9: Etiopathogenesis of DIC. Note that, besides consumption of coagulation factors, including platelets, proteolysis of fibrin preceded by active fibrinolysis of microvascular thrombosis play considerable role in this phenomenon, leading to hemorrhagic diathesis

4 include intermittent skin or mucosal bleeds developing over weeks or months, thrombophlebitis at unusual sites, and deep venous thromboembolism.

Diagnosis

The blood smear shows fragmented burr and helmet-shaped red cells, the so-called *schizocytes*.

This picture is the result of microangiopathy. In addition, platelets are reduced, fibrinogen level is low, prothrombin time, partial thromboplastin time and thrombin time are low, fibrin split products are present in blood, and factor VIII level is low.

Treatment

Early recognition and control of the DIC syndrome and management of the triggering factors (shock, hypoxia, dyselectrolytemia) form the sheet-anchor of successful treatment. An IV line should be set up to avoid repeated venepuncture.

Fresh blood transfusion (preferably platelet infusion for thrombocytopenia, cryoprecipitates for hypofibrinogenemia, fresh or frozed plasma for replacement of other coagulation factors and natural inhibitors) is of definite value.

Exchange transfusion (double volume) assists by eliminating toxins, circulating fibrin split products and activated procoagulants and by supplying the replacement factors.

Anticoagulant therapy is indicated when replacement therapy proves ineffective in controlling

the bleeding, or treatment of primary disease is inadequate or incomplete. The drug of choice, heparin, 1 mg (100 units)/kg, may be given as bolus followed by continuous infusion of 15 to 25 units/kg/hour. Administration of heparin must be monitored by serial measurements of platelet count and plasma fibrinogen concentration.

Remaining supportive measures include vitamin K for correcting vitamin K-dependent factors and steroids (hydrocortisone) in such special situations as meningococemia and purpura fulminans.

Prognosis

Notwithstanding best of treatment, acute DIC has a poor prognosis with a mortality of 50-80%, the highest mortality being in neonates.

HEMORRHAGIC DISEASE OF THE NEWBORN (HDN) [VITAMIN K DEFICIENCY BLEEDING (VKDB)]

The term HDN (hemorrhagic disease of the newborn) is used to describe bleeding in early neonatal period (under one week) which occurs due to fall in vitamin K (VK) dependent coagulation factors. Over the last 2-3 decades two more forms of disease are described – an early HDN– manifesting within 24 hours after birth and associated with certain risk factors; the second late HDN – which is described to occur in late neonatal period and early infancy. For the reasons that bleeding due to VK deficiency is not restricted to

neonatal period and neonatal bleeding is often not related to VK deficiency, it has been suggested that the term HDN be replaced by a more apt term vitamin K deficiency bleeding (VKDB).

Definition, Incidence and Inclusion Criteria

The perinatal subcommittee of International Society on Thrombosis and Haemostasis (ISTH), has defined VKDB as – bleeding due to inadequate activities of VK dependent coagulation factors (II, VII, IX, X), which is correctable by VK replacement. On the basis of age of onset VKDB is classified as Early (onset <24 hours), classical (onset first week of life excluding first 24 hours) and Late (beginning day 8 of life or later). Most cases of late VKDB (L-VKDB) are seen up to 12 weeks of age but to include more such cases the upper age limit was extended to six months.

The diagnostic criteria as follows—in a bleeding infant prolonged prothrombin time (PT) together with normal fibrinogen level and platelet count is highly suggestive of VKDB. Rapid correction of PT after VK administration is confirmatory. Circulating acarboxy proteins – PIVKA (proteins induced in VK absence) are present but this test may not be routinely available.

Incidence of classical VKDB is reported to vary between 0.01-1.5%, while that of L-VKDB in infants without any VK prophylaxis is estimated to be 4-10 per 100,000 births. It is believed to be more common in South East Asia. L-VKDB is mostly seen in exclusively breastfed infants, more common in boys than in girls and in summer than winter months.

Clinical Features

In the classical form gastrointestinal bleeding – hematemesis and/or melena, bleeding from injection or puncture sites, umbilical bleeding commonly occur.

Early VKDB has its onset in first 24 hours of life. It is classically described in babies born to mothers who are malnourished or those who are receiving drugs which have the potential to inhibit VK-activity. Such drugs have included anticonvulsants (carbamazepine, barbiturates and phenytoin), antitubercular drugs (INH, rifampicin) and VK-antagonists (warfarin, phenprocoumon). The incidence among the babies born to mothers receiving these drugs has varied between 6-12%. Early VKDB often presents with serious and life threatening intracranial, intrathoracic,

intra-abdominal or gastrointestinal bleeding, particularly so if the delivery had been “difficult”.

L-VKDB is a disease of exclusively / predominantly breast-fed infants. Usually, they have not received neonatal VK prophylaxis but in countries where oral VK prophylaxis is in vogue, cases have occurred even in those who received such prophylaxis. According to etiology or presence of associated factors, the disease can be classified as – idiopathic – when no risk factor other than breast feeding is identified; and secondary, when additional risk factors are present. The causes of secondary L-VKDB have included cystic fibrosis, biliary atresia, hepatitis, α -1-antitrypsin deficiency, and chronic warfarin exposure. Association with hepatobiliary disease is frequent. Associated or past history of diarrhoeal illness is usually elicited.

Bleeding manifestation in these patients may be in the form of minor skin or mucus membrane bleeds, bleeding from injection sites, gastrointestinal or following minor surgical intervention. Severe life threatening intracranial bleeding is a frequent occurrence, reported in 45-60% cases. These cases at times may have “warning bleeds” such as umbilical oozing, skin bruises or nasal bleeds as initial bleeding manifestations followed few days later by intracranial bleeds. In cases secondary to hepatobiliary disease, symptoms such as dark urine and pale stools may be elicited.

Diagnosis

In a child with bleeding manifestations, initial diagnostic work-up includes a check on the platelet count and PT and PTT estimation. In VKDB, PT and PTT are prolonged. Platelet count is normal. The activity of VK dependent factors (II, VII, IX, X) is decreased. Levels of fibrinogen are normal. PIVKAs are present and their presence is useful in diagnosis even after correction of coagulation defect as they have a long half life. Fibrin degradation products (FDPs) and/ or D-dimer assay will exclude DIC. Correction of PT rapidly (within 30-120 minutes) after VK administration is diagnostic of VKDB. Hereditary defects of coagulation of hemophilia group are excluded as in this group of disorders only PTT is prolonged. Rare defects e.g. factor VII deficiency are excluded on the observation that clinical improvement and significant shortening of PT after VK administration will occur only in VKDB.

In cases with L-VKDB a careful search for associated factors particularly presence of hepatobiliary disease is warranted as many a times L-VKDB may be the only initial clinical finding in such cases.

Treatment

As in all deficiency states, replacement is the treatment required. Replacement VK therapy needs to be rapidly effective as L-VKDB is often associated with potentially life threatening intracranial bleeding. In a child suspected to have the disease intravenous or subcutaneous administration is recommended. Intramuscular (i.m.) administration is avoided to prevent hematoma formation. The effect of VK administration is rapid but some severe cases may require plasma, fresh frozen plasma or prothrombin complex transfusion. Whole blood transfusion may be required in cases with significant blood loss. Meticulous supportive care is needed particularly in cases with intracranial bleeding.

Prevention

For prevention of VKDB, neonatal VK administration is recommended by American Academy of Pediatrics since 1961. VK is administered i.m. though oral administration has also been found to be effective as far as prevention of VKDB in the first week is concerned. Oral administration does not consistently eliminate L-VKDB.

I TP must be differentiated from purpura secondary to aplastic anemia, leukemia, and other infiltrative processes of the bone marrow. In infants, it needs to be distinguished from genetically determined thrombocytopenias. In older children, SLE, lymphomas and AIDS (when they manifest with thrombocytopenic purpura) must be considered. When thrombocytopenic purpura is accompanied by significant splenomegaly, congestive splenomegaly secondary to primary liver disease, lipidosis and reticuloendotheliosis must be excluded.

Poor prognostic indicators are:

- Prothrombin time (PT) > 1.5 times
- Activated partial thromboplastin time (APTT) > 2.5 times

HEMOPHILIA

It is the commonest of the hereditary bleeding disorders, constituting nearly 90 to 95% of such cases.

Classification

- I. *Hemophilia A (Classical Hemophilia)* It results from deficiency of factor VIII, the antihemophilic factor (AHF). It is X-linked recessive, occurring almost exclusively in the males*. The females act as the carriers without manifesting the disease. Hemophilia A accounts for 98% of all the hemophilics. The incidence in the population is 1 in 10 thousands (Fig. 27.10).
- II. *Hemophilia B (Christmas Disease)* It results from deficiency of factor IX, the plasma thromboplastin component (PTC).
- III. *Hemophilia C* It results from deficiency of factor XI, the plasma thromboplastin antecedent (PTA).

Clinical Features

Manifestations depend on the extent of deficiency of the clotting factor. About one-third hemophilics have just mild disease. They are called *subhemophilics*.

Earliest manifestation may be in the form of bleeding from the umbilical cord within few days after birth or excessive bleeding following circumcision.

Later, tendency to have excessive bleeding, contusions or hematomas at sites of minor trauma, epistaxis, and bleeding after tooth extraction or tonsillectomy are the common presenting features. *Hemarthrosis*, especially of knee, ankle and elbow, is a characteristic feature. The joint becomes swollen and painful. In the earlier stages, the hemorrhage within the joint gets absorbed. Repeated attacks may cause inflammation



Fig. 27.10: *Hemophilia*. Note the muscle atrophy and nearly fixed unstable joints from degenerative changes following repeated hemorrhages (hemarthrosis) in a child suffering from classical hemophilia

* Rarely, a female may suffer when an affected male marries a female carrier

and degenerative changes, the joint ultimately becoming immobile, the so-called “fixed joint”.

Bleeding may occur into genitourinary tract, CNS, GIT, liver, spleen, peritoneal or pleural cavity—in fact anywhere. Skin is not spared but, unlike in purpura, petechiae do not occur in hemophilia.

Diagnosis

- I. Clinical picture and family history of the disease on maternal side, especially maternal uncles, are highly suggestive. Hemophilia is, however, sporadic in 30% of instances and it may not be traceable in the pedigree.
- II. Investigations
 - i. *Blood tests* Clotting time is prolonged, bleeding and prothrombin times are normal*. Clot retraction is also normal. Prothrombin consumption is low. Thromboplastin generation is high. The confirmation of the diagnosis is by specific factor assay.
 - ii. *Radiology* It should be done in cases of hemarthrosis. Initially, there is distention of the joint cavity and synovitis. Later, the changes include areas of synovial thickening, demineralization, erosion and contracture. Increased vascularization of joint space results in accelerated bone growth. Thus, premature appearance of ossification centers may occur. Also, there may be complete destruction of articular surface and formation of juxtaarticular cysts.

Antenatal diagnosis is possible at 18-20 weeks of gestation by:

- procuring fetal blood and demonstrating low level of precoagulant component of factor VIII employing DNA probe to amniotic fluid fibroblast
- employing molecular biology technique on chorionic villus sampling
- PCR technique, or
- oligonucleotide primers

Carrier detection is possible by determining that the factor VIII C and FVIII Ag ratio is < 0.6 (normal 1) or by identifying mutation on DNA studies.

* Even BT may be prolonged in some 20% cases of hemophilia

Treatment

A. Specific measures These consist in giving replacement therapy for the missing clotting factor. In case there is severe bleeding, fresh whole blood and, in case of mild to moderate bleeding, fresh frozen plasma are recommended. Factor VIII concentrates, especially recombinant ones, are now preferred over cryoprecipitate as the source of coagulation factors because of their safety. These are dispensed lyophilized powder in containers of 250 or 500 units and need easy reconstitution before actual use.

Dose of factor VIII (units) = Desired rise (unit/dL, percent) × body weight (kg) × 1.3 – 1.5. This should be given 12 hrly.

These are expensive and not freely available in India and other developing countries. Hence, the practical choice in a vast majority of the cases remains cryoprecipitate. It is workable to prepare it in any reasonable blood bank from fresh plasma. A 250 ml of fresh plasma yields one bag of cryoprecipitate that contains 75 to 125 units of factor VIII. A single bag of cryoprecipitate per 5 kg body weight raises the patient's factor VIII level to 50% of normal.

In minor bleeding episodes like mucosal bleeding (epistaxis, small hematomas, mouth bleed and dental extractions, recommended drugs are:

- desmopressin and danazol which raise the factor VIII and perhaps factor IX levels 25 to 50% above baseline.
- antifibrinolytic agents (tranexamic acid, epsilon amino caproic acid) for 5 – 10 days.

In western countries, home treatment that provides for storage of factor VIII concentrates at home and their reconstitution and intravenous infusion right at home is now becoming popular.

B. Symptomatic measures Local treatment of wounds consists of:

- cleansing the open injury,
- rest
- ice: local cold to achieve vasoconstriction
RICE
- compression: pressure bandage,
- elevation of the part
- local application of thrombin powder or foam.

For hemarthrosis, the initial treatment is rest and immobilization of the joint and application of ice bags.

Later, local heat and physiotherapy to prevent ankylosis should be given. For pain, use of analgesics is of advantage. Some authorities favor the use of steroids in cases of hemarthrosis.

C. *Don'ts* include intramuscular injections, contact sports and NSAIDs (including aspirin)

Preventive Care

- Prevention of trauma must begin right from crib (which needs to be padded).
- Regular exercise for strengthening muscles, protecting joints and improving fitness.
- Drugs adversely affecting platelet function, like aspirin and NSAIDs, should be avoided.
- Avoiding contact sports
- Maintaining a healthy body weight to avoid extra stress and strain on joints.
- Hepatitis B vaccine must be given as early as possible since a hemophiliac is likely to be exposed to blood products all through the life.
- Since there is as yet no vaccine against AIDS, a very careful testing of the blood product for HIV before transfusion is the only precautionary measure available with us.

The hemophilic patient is always in danger of *severe bleeding*. Some die in infancy and early childhood. Recurrent hemarthrosis may produce *crippling*. If trauma and infection can be prevented, activity reduced and adequate treatment administered, outlook for life is good. Unfortunately, repeated transfusions may produce *anticoagulation factor*, thus adding to the difficulties in management.

VON WILLEBRAND DISEASE (VWD)

This autosomal dominant disorder is characterized by disproportionate bleeding following minor trauma as observed in hemophilia. However, clotting time is normal and bleeding time is prolonged.

The cause appears to be the deficiency of the so-called von Willebrand factor (vWF), resulting in reduced synthesis of factor VIII and diminished platelet adhesiveness.

Diagnosis is by demonstrating prolonged bleeding time and reduced factor VIII. A noteworthy point is that whereas ristocetin-induced aggregation is normal in classic hemophilia, it is reduced in VWD.

In order to check bleeding, an infusion of fresh or fresh-frozen plasma is usually enough. For serious bleeding, cryoprecipitate therapy is preferred.

IMMUNE THROMBOCYTOPENIC PURPURA (ITP)

This is the new nomenclature for the so-called *idiopathic thrombocytopenic purpura*. Also known as *Werlhof disease* and *purpura hemorrhagica*, it is characterized by spontaneous small hemorrhages in the skin, mucous membrane and internal organs. There are increased bleeding time, gross deficiency in the number of circulating platelets and normal or increased megakaryocytes in the bone marrow.

ITP is of special interest in pediatric practice. It is estimated that three-fourth of all cases of this disease are children. Secondly, it has the following distinctive features that are not seen in adults:

- i. Both sexes seem to be equally affected in children whereas adult form is known to have a predilection for the females.
- ii. About 85 to 90% children with ITP may have spontaneous remission. In adults, remission occurs in just one-third of cases.
- iii. Unlike in adults, antiplatelet-autoagglutinins have been infrequently demonstrated in children suffering from this disorder.

Etiopathogenesis

Etiology is not entirely clear. There is a widespread feeling that ITP, like acquired autoimmune hemolytic anemia, may well be one of the autoimmune diseases. The evidence is, however, equivocal. As already mentioned, autoagglutinins are only infrequently demonstrated in the childhood form, a point most often cited against this hypothesis. Here it is worth remembering that there are many other serum factors that, though present in certain diseases of adults, are absent in the childhood counterparts. For instance, in glandular fever (infectious mononucleosis), the heterophil agglutin test is very frequently negative in children whereas it is often positive in adults. Serology in rheumatoid arthritis is positive in 80% of adult patients but very rarely so in children.

In a large proportion of the cases of ITP, a mild viral upper respiratory infection precedes by 1 to 4 weeks. In view of the high frequency of such infections in childhood, this observation cannot be considered to be causally related.

The possible role of spleen remains to be established. The basic pathology that causes bleeding in ITP is two-fold: increased vascular permeability and thrombocytopenia.

Clinical Features

The usual age of onset is 3 to 8 years, the median being 5 years.

Two forms of the disease are known: acute and chronic.

Acute type This is the type generally seen in childhood. In about one-half of the cases, it is preceded by an infection, especially of the upper respiratory tract, 1 to 4 weeks earlier. Onset of ITP is sudden and the child presents with bruising, petechiae, and bleeding from the mucosal surface such as that of nose, gums and urinary tract. Spleen may be just palpable in 25% of the cases (Figs 27.11 and 27.12).

After a few days, there is reduction in bleeding due to an improvement in capillary integrity though thrombocytopenia is still present. Death may occur in the acute phase from uncontrolled bleeding or intracranial hemorrhage (ICH). ICH is, however, infrequent (1 in 1000). Its risk is greatest at platelet count under 10,000/cmm. The patient may completely recover in 6 months. A small percentage of cases pass on to the chronic stage.

Chronic type When ITP exists for more than 6 months despite steroid therapy, it is termed "chronic". This form accounts for about 10 to 15% cases of childhood ITP. There is usually a prolonged history of bleeding or a bruising tendency. The course is marked by relapses and remissions. The bleeding is usually less severe due to less severe involvement of the capillaries. Chronic cases seldom die from this condition which may persist for years together.

Diagnosis

When a child presents with purpura, a careful history should be obtained with special reference to a preceding infection, recent drug therapy, and possible exposure to irradiation, and chemical agents such as toxins, sprays and insecticides.

Diagnostic tests should include:

- i. Tourniquet/Hess test* is positive
- ii. Complete hemogram to find out hemoglobin status and any abnormal cells

* Hess test: On the flexor aspect of the forearm, mark an area 2.5 sq cm. Notice if any purpuric spots are present. Now apply the blood pressure cuff. Record systolic and diastolic pressures. Maintain the pressure between the two readings for 5 minutes. After the cuff is deflated appearance of more than 8 fresh spots in the circumscribed area indicates a positive test. In case numerous petechiae appear before the deadline of 5 minutes, deflate the cuff immediately



Fig. 27.11: ITP. Note the subconjunctival hemorrhage. Despite bruising and petechial rash, and epistaxis, the child appeared fairly well. Platelet count was $18 \times 10^9/L$



Fig. 27.12: Idiopathic thrombocytopenic purpura (ITP): Note petechiae over abdomen

- iii. Platelet count is usually less than 20 thousands/cmm
- iv. Bleeding, clotting and clot retraction times—are abnormal since they depend on platelet function
- v. Bone marrow to ascertain the adequacy of megakaryocytes and to rule out leukemia and aplastic anemia.

In ITP, normal or increased numbers of megakaryocytes are seen. Some megakaryocytes are immature with deep basophilic cytoplasm. Scanty platelet budding may be present. Modest eosinophilia is usual.

- vi. Culture from the nasopharynx, antibody titers and an LE cell preparation.

Differential Diagnosis

ITP must be differentiated from purpura secondary to aplastic anemia, leukemia, and other infiltrative processes of the bone marrow. In infants, it needs to be distinguished from genetically determined thrombocytopenias. In older children, SLE, lymphomas and AIDS (when they manifest with thrombocytopenic purpura) must be considered. When thrombocytopenic purpura is accompanied by significant splenomegaly, congestive splenomegaly secondary to primary liver disease, lipidosis and reticuloendotheliosis must be excluded.

Treatment

1. Acute ITP

Management consists in minimizing the risk of severe bleeding by an initial limitation of activity. Active bleeding should be controlled. Drugs like aspirin and antihistaminics which have antiplatelet function should be avoided. Platelet transfusions are reserved for severe bleeding not responding to drug therapy. In such cases large doses of platelets are required.

Various forms of corticosteroids – prednisolone, methylprednisolone and other drugs like IVIg and anti Rh globulin (anti D) have been used to raise the platelet counts. However, the drugs have not consistently been proven to be of value in moderate or mild thrombocytopenia. Opinions differ but there is general agreement that children with platelet count less than $20,000/\text{mm}^3$ or having significant mucosal bleeding (and ICH) should be given drugs. Prednisolone is frequently used drug. The dose is 2 mg/kg/day. This dose should be continued for 2 weeks and tapered over third weeks even if platelets remain low. An initial high dose has been used (4 mg/kg/day for two days). Methylprednisolone is used as 30 mg/kg/day for three days. IVIg is used in developed countries as first time drug but is very expensive as compared to steroids. A dose of 400 mg/kg/day for 5 days or 1 gm/kg/day for 2 days have been used. Intravenous anti D can be used in Rh positive individuals.

2. Chronic ITP

Most cases with chronic ITP have mild to moderate thrombocytopenia and cutaneous or occasional mucosal bleeding. Such cases do not require much treatment. Only cases with persistently severe thrombocytopenia ($<20,000/\text{mm}^3$) or with significant mucosal bleed need to be treated. For such cases various forms of therapy have been used. Methylprednisone (30 mg/kg/day for 3 days followed by 30 mg/kg for one day every month); high dose dexamethasone (20 mg/m²/day for 4 days every month for 6 months), long term low dose steroids, IVIg, intravenous anti-D have been used with variable results. Doing splenectomy in children with chronic ITP is a difficult decision. Splenectomy has been successful in two-third of the patients but as more long term follow up data is accumulating, many cases with initial response have relapsed.

The cases persisting to be thrombocytopenic after splenectomy are called “refractory ITP”. Such cases are difficult to treat. The options include vincristin, cyclophosphamide, cyclosporin, interferons, colchicine, azathioprine, danazol, dapsone, high dose vitamin C anti-CD20 antibody, plasmapheresis etc. Recently, in adults an association with *Helicobacter pylori* infection has been demonstrated and improvement in platelet count is reported after its eradication. A long list of therapeutic options only suggests that each therapy works only in a minority of cases.

Prognosis

The conservative measures lead to recovery in 85 to 90% cases within 6 months. The remaining 10 to 15% pass into the chronic phase. In the latter, recovery may be expected in about 75% following splenectomy; the rest show lessening of the manifestations.

WISKOTT-ALDRICH SYNDROME

This, an X-linked recessive disorder, is characterized by a triad of eczema, thrombocytopenic hemorrhagic diathesis and immunodeficiency leading to enhanced vulnerability to infections.

The disorder represents a unique state in which thrombocytopenia results from abnormal platelet formation or release in spite of adequacy in number of megakaryocytes. Many megakaryocytes are, however, of bizarre morphology. The platelets are

reduced in number and half of the normal size. They also have decreased number of alpha granules, dense bodies and mitochondria. Further, they are less aggregatable and suffer from abnormalities of energy metabolism.

A small proportion of patients (5%) develop lymphoreticular malignancies.

At present, treatment of choice is splenectomy. A significant improvement in thrombocytopenia follows this intervention. In view of enhanced risk of fulminant sepsis, it is mandatory to give prophylactic penicillin to the patients who undergo splenectomy.

A small proportion of cases may respond to transfer factor or bone marrow transplantation.

DRUG-INDUCED THROMBOCYTOPENIA

Drugs such as sulfas, cotrimoxazole, chloramphenicol, carbamazepine and diphenylhydantoin (phenytoin) may occasionally cause thrombocytopenic purpura.

The modus operandi is either a megakaryocyte insult or an immune-mediated process in which the drug acts as a hapten.

Withdrawal of the offending agent reverses the abnormality.

ANAPHYLACTOID (HENOCH-SCHOENLEIN) PURPURA

Also termed *allergic nonthrombocytopenic purpura*, it is far less frequent than the idiopathic thrombocytopenic purpura. In all probability, it is a collagen disorder, characterized by vasculitis. And presents with widespread purpuric lesions (particularly urticaria-like skin eruptions) with involvement of the joints (Schoenlein purpura) and/or abdominal viscera (Henoch purpura). Progressive renal involvement carries bad prognosis.

Clinical Features

Henoch purpura is dominated by signs of acute abdomen. At times the picture almost mimics intestinal obstruction, volvulus, intussusception or appendicitis.

Schoenlein purpura is dominated by signs of arthritis, especially of the knees and ankles (Figs 27.13 and 27.14). Often, it has been mistaken for rheumatic or rheumatoid arthritis. Acute glomerulonephritis may be associated with this variety.



Fig. 27.13: *Henoch-Schoenlein purpura*. Note the ecchymotic patches. Arthritis of knees and ankles was present. The presenting reason for hospitalization was colicky abdominal pain with vomiting. Hemogram was essentially normal



Fig. 27.14: *Henoch-Schoenlein purpura*

Diagnosis

Hematologic investigations reveal normal results. *Streptococcus hemolyticus* may be cultured from throat swab. ASO titer may be raised. In case of involvement of the kidneys, urine shows varying degree of albumin, red cells and casts. IVP may show poor functioning and the renal biopsy changes of glomerulonephritis.

Treatment

It is a self-limiting disease. However, bed rest, adequate nutrition and symptomatic treatment are required as and when indicated.

Acute renal failure warrants therapy as in acute glomerulonephritis.

Indications for steroid therapy include:

- Life-threatening intestinal hemorrhage, obstruction, perforation or intussusception.
- CNS involvement.

Prognosis

Children who do not recover in 4 to 6 weeks may go into a chronic phase and die from renal failure as also from cerebral or gastrointestinal bleeding.

PURPURA FULMINANS

This is a rare life-threatening condition characterized by acute infarction (hemorrhage) of skin that accompanies or follows bacterial (*Staph. aureus*, *H. influenzae*, *Klebsiella*, *Pseudomonas aeruginosa*, *N. meningitidis*) or viral (chickenpox, URI) infection.

Exact pathogenesis is unclear. A close resemblance to Schwartzman reaction is, however, known. Hematologic picture is that of DIC.

Management includes supportive therapy, treatment of shock, antibiotics to control the causative infection or to prevent secondary infection, and heparin and steroids in combination or alone.

LEUKOCYTE DYSFUNCTION

Opsonization is the remarkable ability of the neutrophils to recognize foreign antigen through humoral factors (opsonins) like heat stable IgG antibodies and heat stable complement C3b. Dysfunction in opsonization and phagocytosis may cause a number of disorders such as Chediak-Higashi syndrome chronic granulomatous disease and neutropenia.

Chediak-Higashi syndrome, an autosomal recessive disorder of PML function, is characterized by recurrent infections, oculocutaneous albinism, neutropenia and, occasionally, hepatosplenomegaly, lymphadenopathy and lymphoid infiltration of tissues mimicking ALL.

Chronic granulomatous disease, an X-linked disorder, is characterized by inability to kill bacteria, resulting in recurrent bacterial infections of skin, lymphadenopathy, poor healing, hepatosplenomegaly, multiple live abscesses, pneumonia, diarrhea, conjunctivitis, otitis media, sinusitis, osteomyelitis, etc.

Neutropenia is characterized by PML count $< 1500/mm^3$ and may be congenital (cyclic neutropenia, chronic benign neutropenia) or acquired (leukemia, lymphoma, and solid tumors).

NEUTROPENIA

An absolute fall in the number of circulating neutrophil in blood may range from mild to profound (Table 27.13).

Table 27.13: Classification of neutropenia

Classes	Ranges
Mild	1001-1500/mm ³
Moderate	501- 1000/mm ³
Severe	$< 500/mm^3$
Profound	$< 100/mm^3$

Etiology

Table 27.14 gives the three major types of neutropenia depending on etiology.

Febrile Neutropenia

Development of unexplained fever in a majority of the subjects with malignancy is secondary to neutropenia as a result of certain infections which may be viral (hepatitis, HIV, RSV, varicella, rubella, influenza), bacterial (*Salmonella*, *Staph. aureus*, *Streptococcus*, *M. tuberculosis*, *Brucella*, *Listeria*), fungal (*Candida*, *Aspergillus*, *mucormycosis*) and parasitic. Since febrile neutropenia is almost silent because of suppression of manifestations of infection, it can be quite life-threatening.

Clinical Features

The most frequent sites of serious infection are blood, lungs, soft tissues and mucosal surfaces (gingivitis,

Table 27.14: Major types of neutropenia

<i>Defects of Uncommitted Stem Cells</i>
Reticular dysgenesis
Cyclic neutropenia
T and B lymphocyte disorders
<i>Defects of Committed Stem Cells</i>
Chronic benign neutropenia without infection
Severe familial neutropenia
Chediak-Higashi syndrome
Cartilage hair dysplasia
Schwachman-Diamond syndrome
<i>Acquired Disorders</i>
Myelofibrosis: Leukemia, lymphoma, solid tumors, Gaucher disease, osteopetrosis, radiation
Infections: HIV, HB, rubella, RSV, varicella, influenza, <i>Salmonella</i>
Drugs/chemicals: Chemotherapy for malignancy, heavy metals, benzene-containing organic compounds

mucositis), GIT (esophagitis, typhilitis with right lower quadrant abdominal pain and a lump, anorectal infections).

Diagnosis

Since classic signs and symptoms of infection are likely to be missing, a high index of suspicion is the benchmark for diagnosis of febrile neutropenia. Besides special sensitivity to subtle manifestations of infection, investigations should include complete blood count (CBC), differential blood count, platelet count, LFT, renal function tests, blood cultures for both aerobic and anaerobic pathogens and aspiration or biopsy for bacterial, fungal, mycobacterial and viral strains and cultures.

Management

Initial empirical therapy consists of parenteral combination chemotherapy, e.g. a third generation cephalosporin plus an aminoglycoside/a beta-lactam antimicrobial agent, ceftazidime plus amikacin, vancomycin alone. Duration of chemotherapy should be till the resolution of neutropenia or for a period of 14 days.

Persistence of fever despite the initial empirical therapy is an indication for modifying the initial therapy plus introducing an antifungal agent (amphotericin B).

Hematopoietic growth factors (stem cell growth factors: GM-CSF, G-CSF, granulocyte transfusion; monoclonal antibodies, interleukin, interleukin

receptor antagonists, interferon, cytokines) may be employed to boost the host defenses as adjuvant to antimicrobial therapy.

Prevention

It comprises

- Isolation techniques: HEPA (high efficiency particulate air) filtered room, neutropenia precautions (gloves, masks, mopping rather than brushing, soft tooth brush. Low microbial diet, hand washing).
- Prophylactic antibiotics, including fungal prophylaxis with nystatin. Clotrimazole, amphotericin B or fluconazole.

VENOUS THROMBOEMBOLISM

Etiopathogenesis

Predisposing factors include frequent use of central venous catheter (CVC), malignancy, chemotherapy, total parenteral nutrition (TPN), obesity, sickle cell disease, liver disease, sepsis and nephrotic syndrome. Antiphospholipid antibodies (APA), though known for a definite role in adults, remain to be investigated for their contribution in causing VTE.

Clinical Features

These include painful swelling and discoloration of the affected limb, inguinal or abdominal pain, fever, malfunctioning of the central venous catheter (CVC) and evidence of collateral circulation.

Diagnosis

Hematologic studies include PT, APTT, fibrinogen and platelet count, D-dimer test (more important as a predictive test than a diagnostic test), anticardiolipin antibodies, LA and tests for inherited prothrombin defects.

Venogram is the gold standard for diagnosing equivocal cases and thrombosis involving upper limbs.

Color Doppler/duplex ultrasound is quite dependable for diagnosis of thrombosis of lower limbs and distal veins of upper limbs.

For diagnosis of pulmonary embolism, ventilation/perfusion (V/Q) scan and spiral CT scans are employed.

Treatment

The cornerstone of treatment of VTE is standard heparin as such or in conjunction with AT-III.

Thrombolytic agents (urokinase, streptokinase and recombinant plasminogen activator) are used to cause rapid clot lysis, resulting in prompt lysis of the obstruction.

Oral anticoagulants (Warfarin) is good for long-term anticoagulant therapy.

POLYCYTHEMIA (*Erythrocytosis*)

Polycythemia, a Greek term, signifies an increase above the normal in the number of red cells in the blood, usually accompanied by an increase in the hemoglobin level and packed red cell volume.

Primary polycythemia may be of two types. *Polycythemia vera*, a chronic myeloproliferative disease characterized by hyperplasia of the marrow, excessive red cell production, high blood viscosity and hemorrhagic tendencies, is seldom seen in childhood.

Benign familial polycythemia or *primary erythrocytosis* is the commonest type seen in pediatric practice. It is transmitted as an autosomal dominant (occasionally autosomal recessive) trait. Manifestations include headache, lethargy, plethora and splenomegaly. RBC count may be as high as 10 million/cmm with a hemoglobin of 27 g/dl and hematocrit of 80%. The treatment of choice is phlebotomy.

Secondary polycythemia results in response to a hypoxic state that causes poor oxygen saturation of blood. Thus, it may occur in cyanotic congenital heart disease, chronic pulmonary disease such as cystic fibrosis, pulmonary arteriovenous fistula or cavernous hemangioma of the lung, gross obesity as in Pickwickian syndrome, methemoglobinemia, sulfhemoglobinemia, and in subjects living at high altitude.

Nonhypoxic causes of secondary polycythemia include renal and brain tumors, hydronephrosis, Cushing disease, cobalt therapy and rare hemoglobinopathies.

Some polycythemia is a normal observation in newborns; it may be particularly exaggerated in a twin, in a preterm or small-for-dates infant, in an infant of a diabetic mother, and in babies suffering from Down syndrome and congenital adrenal hyperplasia.

Relative polycythemia may result from dehydration such as occurring in gastroenteritis, in stress, in hypertension and in diuretic therapy.

Severe polycythemia may cause such hemorrhagic defects as thrombocytopenia, DIC, and increased anticoagulants with high fibrinolytic activity.

Treatment of secondary polycythemia consists in correction of the cause. If that is not possible or if polycythemia is quite severe, treatment of choice is phlebotomy and/or isovolumetric exchange transfusion to restore the hematocrit to normal limits.

HEMOPOIETIC STEM CELL (HSC) TRANSPLANTATION

The term, *stem cell*, refers to the cell that has an extensive self-maintaining (self-renewal) capacity extending throughout the entire lifespan of the organism. The term, *human stem cell transplantation* (HSCT), therefore, implies the application of hemopoietic progenitor cells to reestablish normal hemopoiesis in subjects with serious hematological, immunological and malignant diseases.

Principle Indications

- Leukemias, especially AML and ALL.
- Congenital hemolytic anemias, especially thalassemia major and sickle-cell disease.
- Bone marrow failure, especially aplastic anemia, Blackfan-Diamond syndrome, Fanconi anemia.
- Lymphoproliferative disorders, especially HL, NHL and multiple myeloma.
- Solid tumors, especially Wilms' tumor, neuroblastoma, and Ewing sarcoma.
- Immunodeficiencies, especially SCID, CGD, Wiscott-Aldrich syndrome and Chédiak-Higashi syndrome.
- Miscellaneous: Mucopolysaccharidosis, leukodystrophies.

Types

1. Syngenic HSCT when stem cell is obtained from identical twin.
2. Allogenic HSCT when stem cell is obtained from a HLA matched sibling.
3. *Autologous HSCT* when normal appearing marrow is obtained from the patient himself on cytotoxic drugs. This marrow is preserved and subsequently transfused back into him.

Alternative for obtaining stem cell is blood, including umbilical cord blood.

Complications

- Graft versus host disease (GVHD), both acute and chronic.

- Superimposed infections, especially atypical pathogens like *Mycoplasma pneumoniae*, *Legionella*, *Chlamydia*, *H. influenzae*, *varicella virus*, *CMV*, *RSV*, *herpes*, etc.
- Protozoal infections, especially *Pneumocystis carinii*.

Future Direction

With constant increase in our understanding, it should be possible in the foreseeable future to improve the precision with which cells are targeted and therapies designed.

BLOOD COMPONENT THERAPY

Whole blood transfusion is indicated in only blood loss with hypovolemic shock. However, appropriate *blood component* should be employed for specific conditions.

Classification

- Unmodified*
Cellular Packed RBCs, platelets, granulocytes
Plasma Fresh frozen plasma, cryprecipitate, factor components
- Modified*
Irradiated RBCs, platelets, granulocytes
Leukocyte depleted RBCs, platelets
Saline washed RBCs, platelets

Unmodified Components

Packed RBCs

Here some of the plasma is removed from whole blood. For improvement of oxygen-carrying capacity in chronic anemia with hypoxic manifestations as also CCF, this is the best product. Dose is 10 ml/kg over 3-4 hours. A transfusion of 3 ml/kg increases Hb concentration by around 1 g/dl.

Indications

Neonates

- Physiologic anemia of infancy/anemia of prematurity
- Hb < 10 g/dl if symptomatic
- Hb < 13g/dl in cardiopulmonary disease
- Hb <10 g/dl in FTT
- Replacement of iatrogenic blood loss
- Situations requiring large volume transfusions, e.g. exchange transfusion

Infants and older children

- Hb < 7 g/dl, symptomatic anemia
- Blood loss due to hemorrhage

Platelets

Indications

- Platelet count < 50×10^9 /L in premature infants
- Platelet count < 5×10^9 /L
 active bleeding
 major invasive or surgical procedure
- Platelet count < 20×10^9 /L
 marrow failure
 minor surgical procedure
- Cardiovascular bypass/ECMO with excessive hemorrhage
- ITP

Dose 0.1 unit/kg raises platelet counts by 30,000/cmm.

Granulocytes

Indications

- Neonatal sepsis with meningitis, septic shock or necrotizing enterocolitis
- Absolute neutropenia < 3×10^9 PMN cells/cmm during first week, < 1×10^9 PMN cells/cmm thereafter

Dose $1-2 \times 10^9$ granulocytes/kg BW (10-15 ml/kg BW) every 24 hours.

Fresh Frozen Plasma

It is the fluid portion of the blood unit that is centrifuged, separated and frozen at less than -30°C within 6 hours of collection.

Indications

- Severe hemorrhagic disease of the newborn (HDN) with vitamin K-dependent coagulopathy
- Replacement of isolated factor deficiencies in the absence of specific component therapy
- DIC
- Replacement therapy in antithrombin III, protein C or S deficiency
- Reversal of hemostatic disorders in dilutional coagulopathy from massive transfusion
- Reversal of adverse effects in a baby born to the mother on such agent as phenobarbital or phenytoin

- Thrombotic thrombocytopenic purpura (TTP) for therapeutic plasma exchange
- Coagulopathy due to drug (L-asparaginase) therapy
- Invasive procedures provided that PT and/or PTTK is quite high (1-1.5 times than normal).

Dose 10 ml/kg BW over 1-2 hours, to be repeated every ½ hour until hemorrhage is controlled.

Cryoprecipitate

Cryoprecipitate is obtained by thawing fresh frozen plasma (FFP) at 4°C. It provided fibrinogen, F VIII, FvWF and F XIII 5 times as high as in FFP.

Indications

- Classical hemophilia (factor VIII deficiency) when factor concentrates are not available
- von Willebrand disease
- Congenital factor XIII deficiency
- Congenital hypofibrinogenemia
- Acquired hypofibrinogenemia secondary to DIC and ECMO
- As fibrin sealant in preparing fibrin glue.

Dose 20 ml/kg.

Modified Components

Gamma-irradiated Blood Products

Indications

The aim of gamma-irradiation is to prevent graft-versus-host disease (GVHD) due to the immune response mounted by the donor T-lymphocytes against host tissues.

- Severe immunodeficiency
- Intrauterine or extrauterine transfusions
- Transfusions from first degree relatives with threat of graft-versus-host disease (GVHD)

Dose 25-30 Gy or more.

Saline Washed RBCs

Indications

- Prevention of urticarial reactions in hypersensitivity to plasma
- Prevention of anaphylaxis in IgG deficiency

- Prevention of nonhemolytic febrile transfusion reactions in thalassemia subjects receiving multi-transfusions
- Removal of complement in paroxysmal nocturnal hemoglobinuria

Saline Washed Platelets

These are beneficial in severe allergic reactions to blood transfusion and in neonatal alloimmune thrombocytopenia.

FURTHER READING

Articles/Chapters

1. Choudhry VP, Kashyap R. Idiopathic thrombocytopenic purpura (ITP). In Gupte S (Ed): *Recent Advances in Pediatrics (Special Vol. 7: Hematology)*. New Delhi: Jaypee 2000:144-155.
2. Dutt S, Yadav SP, Sachdeva A. Management of hemophilia bleed. *Blood & Cancer in Child* 2007;1:4.
3. Dutt S, Yadav SP, Sachdeva A. Algorithmic approach to bleeding child. *Blood & Cancer in Child* 2007;1:1.
4. Ghatge S, Parikh PM. Hemopoietic stem cell. In Gupte S (Ed): *Recent Advances in Pediatrics (Special Vol. 7: Hematology)* 2000:331.
5. Khanna VK, Biswas A. Thalassemia: What is new in chelation therapy? In Gupte S (Ed): *Recent Advances in Pediatrics (Special Vol. 7: Hematology)*. New Delhi: Jaypee 2000:46.
6. Marwaha N, Marwaha RK. Disseminated intravascular coagulation. In Gupte S (Ed): *Recent Advances in Pediatrics (Special Vol. 7: Hematology)*. New Delhi: Jaypee 2000:206.
7. Sachdeva A. Febrile neutropenia. In Gupte S (Ed): *Recent Advances in Pediatrics (Special Vol. 7: Hematology)*. New Delhi: Jaypee 2000:251.
8. Shah N, Lokeshwar MR, Bavdekar SB. Iron deficiency anemia, In Gupte S (Ed): *Recent Advances in Pediatrics (Special Vol. 7: Hematology)*. New Delhi: Jaypee 2000:1.
9. Singh UK, Kumar R. Sick cell disease. In Gupte S (Ed): *Recent Advances in Pediatrics*-10. 2000:323-334.
10. Zlotkin S. Control of anemia. The time to act is now. *Indian Pediatr* 2007;44:2007.
11. Siddhivinayak H, Bhavne S, Bavdekar A, et al. Low dose "sprinkles" – An innovative approach to treat iron deficiency anemia in infants and children. *Indian Pediatr* 2007;44:91.

Books/Monographs

1. Lewis SM, Bains BJ, Bates I. *Dacie's and Lewis Practical Hematology*, 9th edn. London: Churchill Livingstone 2001.
2. Greer JP, Rodgers GM, Foerster, et al. *Wintröbe's Clinical Hematology*, 11th edn. Philadelphia: Lippincott Williams and Wilkins 2004.

CHAPTER



28

Pediatric Oncology

Suraj Gupte, AM Graham

INTRODUCTION

With the availability of advanced diagnostic techniques and improved therapeutic and supportive care, cure rate in childhood cancer has considerably improved. Around 60-70% of pediatric cancer is now curable. In some malignancies, cure rate has reached as high as 90%. According to a conservative estimate, nearly 50,000 children suffer from cancer every year. In terms of frequency, leukemias (33%) top the list followed by brain tumors (20%) and lymphoma (12%). These three malignancies together, therefore, account for a vast majority of the pediatric cancer in India.

LEUKEMIA

Leukemia is characterized by persistent and enormous production of immature white cells. It is responsible for an overwhelming majority of the childhood malignancies. The incidence of leukemia in various pediatric centers in India varies from 0.3 to 1.2%.

About 98% children suffering from leukemia have *acute type* of the disease. Mostly it is lymphocytic leukemia (ALL) which accounts for 76% of the cases. Acute nonlymphocytic leukemia (ANLL) is responsible for 20% and chronic myelocytic leukemia (CML) and others together for a meagre 4%.

Table 28.1 presents categorization of leukemias as such and Table 28.2 French-American-British (FAB) classification of leukemias. Immunologic classification of ALL is given in Table 28.3.

Chronic leukemia is uncommon in childhood. Chronic lymphocytic leukemia (CLL) is particularly very rare in pediatric practice. A case died under our

Table 28.1: Categories of childhood leukemia

<i>Acute lymphocytic leukemia (ALL)</i>
1. Standard-risk ALL (Null cell)
2. High-risk ALL
• T-Cell ALL
• B-Cell ALL
<i>Acute Nonlymphocytic leukemia (ANLL)</i>
M1 (myeloblastic, no maturation)
M2 (myeloblastic, some maturation)
M3 (hypergranular promyelocytic)
M4 (myelomonocytic)
M5 (monocytic)
M6 (erythroleukemia)
<i>Chronic myelocytic leukemia (CML)</i>
1. Adult form
• chronic phase
• blast crisis
2. Juvenile form—Congenital leukemia

care at the SMGS Hospital, Jammu, in 1975. Chronic myelocytic leukemia (CML), adult or juvenile type, is, of course, occasionally encountered.

Another important feature of childhood leukemia is the *aleukemic leukemia* in around half of the cases. In this form TLC is either normal or low.

Congenital leukemia and higher incidence of acute leukemia in Down syndrome are well known.

Etiology

It is as yet unknown. Factors such as genetic, exposure to ionizing radiation and viral particles may play an etiologic role.

There are congenital/hereditary conditions in which risk of leukemias is considerably higher (Table 28.4).

Table 28.2: FAB classification of acute lymphatic leukemia (ALL)

Feature	L ₁	L ₂	L ₃
Cell size	Small	Large heterogenous	Large homogenous
Nuclear chromatin	Homogenous	Variable heterogenous	Finely stippled homogenous
Nuclear shape	Regular occasional cleft	Irregular with cleft and indentation	Regular and round
Nucleoli	Absent	One or even more	One or even more
Cytoplasm	Scanty	Variable	Moderately abundant
Basophilic cytoplasm	Slight	Variable	Quite deep
Cytoplasmic vacuolation	Variable	Variable	Prominent

Table 28.3: Immunologic classification of acute lymphatic leukemia (ALL)*B-cell precursors*

- Stem cell
- Early pre-B cell: cytoplasmic Ig negative (cIg -). These cells often express the CD 19 and CD 10
- Pre-B cell: cytoplasmic Ig positive (cIg +). Mature B cell whose hallmark is sIg +ve. CD 10 is found in 80% of all null cell leukemias.

T-cell precursors

- Stem cell
- Early (Stage 1) intrathymic differentiation; most T-cell leukemias arise from this stage
- Intermediate (Stage 2)
- Late (Stage 3)

Table 28.4: Congenital/hereditary conditions associated with increased risk of leukemias

- Ataxia telangiectasia
- Congenital X-linked immunodeficiency
- Down syndrome
- Fanconi anemia
- Bloom syndrome
- Kostman syndrome
- Klinefelter syndrome
- Neurofibromatosis
- Immunodeficiency
- Ataxia telangiectasia

Clinical Features

Acute leukemia is a great immitator. The clinical presentation may be vague and varied, resembling almost any disease.

In ALL, the peak incidence occurs in the first 5 years of life, particularly in 2 to 5 years age group. The second peak occurs between 8 and 10 years of age.

Tables 28.2 and 28.3 give FAB and immunologic classifications of ALL respectively.

The onset is acute or insidious. The initial manifestations may include progressive pallor, anorexia,



Fig. 28.1: ALL. Note the black eye. The patient had severe anemia, sternal tenderness, generalized adenopathy and hepatosplenomegaly. Bone marrow was full of “blast” cells

weakness, fever, malaise, lymphadenopathy, hepatosplenomegaly, purpura, nasal bleed, black eye etc (Fig. 28.1). Bone or joint pains and, occasionally, swelling with or without sternal tenderness, hematemesis, melena, hematuria and sores in mouth are the other common presenting features. At times, excessive bleeding after a minor operation like dental extraction or a minor injury may be the first alarming manifestation. Leukemic infiltration of skin may cause pea-sized papules. Occasionally, arrhythmias with heart block may occur.

CNS involvement leads to meningeal leukemia. It may present with headache, vomiting, drowsiness or unconsciousness, convulsions or cranial nerve involvement. CSF shows increased proteins, low sugar and pleocytosis. Even blast cells may be seen.

In ANLL the presenting features include rapidly progressive pallor, fever, active bleeding, bone pain, GIT upset and gingival swelling from infiltration with leukemic cells. Preceding these manifestations, some

subjects may complain of fatigue and recurrent infections over a period of a year or so. Signs include hepatosplenomegaly, marked lymphadenopathy and, in some cases, joint pains, and CNS findings. Leukemic infiltration may cause proptosis.

In *CML* (adult type), onset is insidious with progressive enlargement of spleen which may become firm and reach into the pelvis (Fig. 28.2). Most cases occur around 10 to 12 years of age.

In *CML* (juvenile type), occurring in children under 2 years, manifestations include eczema, lymphadenopathy, recurrent bacterial infections and hepatosplenomegaly (Fig. 28.3).

In *congenital leukemia*, an infant with a chromosomal abnormality (trisomy 21 in particular) is born with hepatosplenomegaly, petechiae, ecchymoses, cutaneous nodules and CNS involvement, leukocytosis with immature myeloid forms, and thrombocytopenia. Differential diagnosis is from neuroblastoma, leukemoid reaction (erythroblastosis fetalis, severe congenital infections), and myeloproliferative disorders occurring in trisomy 21 or chromosome 21 mosaicism.

Diagnosis

ALL The characteristic laboratory findings are moderate to severe anemia, thrombocytopenia and TLC under 3,000/cmm. In 1/4th cases, platelet count may exceed 100,000/cmm and TLC more than 50,000/cmm*.

Demonstration of primitive cells ("blast cells") gives a definite clue to the diagnosis. This, however, needs confirmation from bone marrow which is likely to be nearly completely replaced by leukemic lymphoblasts (Fig. 28.4). A needle biopsy of marrow may be needed in some cases for this purpose.

X-ray chest for a mediastinal mass and LP for leukemic cells are useful investigations.

ANLL Diagnostic profile is virtually on the same lines as in *ALL*. When cytology is consistent with *ANLL* of type M3, a coagulogram must be done for DIC and as baseline parameters for future reference.

CML The most striking laboratory finding is a TLC which may exceed 100,000/cmm with all forms of

* Leukemoid reactions occurring in various conditions like gram-negative septicemic, enteric fever and miliary tuberculosis should be ruled out. Blast cells are never seen in these diseases



Fig. 28.2: Massive enlargement of spleen in chronic myeloid leukemia

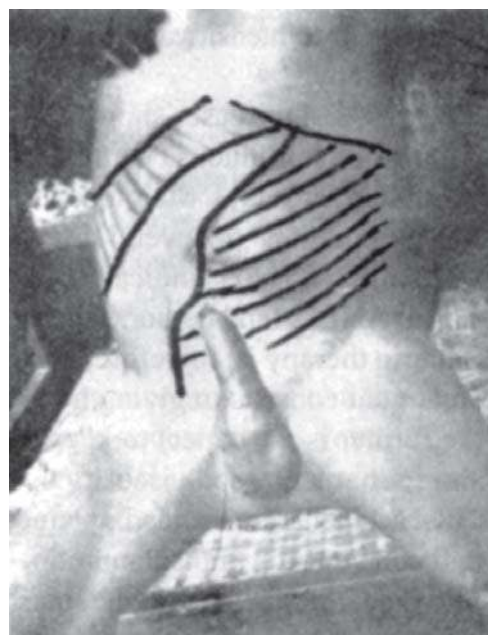

Fig. 28.3: Chronic myeloid leukemia. Note gross splenohepatomegaly and priapism

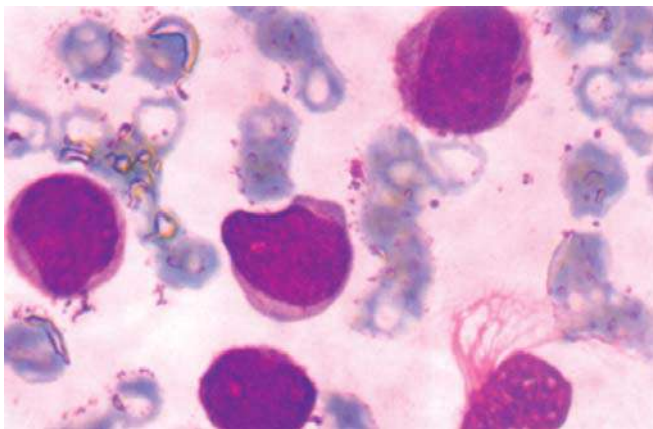

Fig. 28.4: Bone marrow in ALL. Note the large number of blast cells

4

myeloid cells and remarkable eosinophilia and basophilia.

Bone marrow is hypercellular with normal myeloid cells in all stages of differentiation. There may be increase in number of megakaryocytes.

It is advisable to conduct chromosomal studies for Philadelphia (ph1) chromosome which is pathognomonic for CML.

Treatment

ALL The most effective regimen at present available for the most common form of ALL, “null cell ALL” or “standard-risk ALL”, is given in Table 28.5. This gives remission in about 95% of the ALL subjects with the following features:

- Age over 2 years and under 10 years
- TLC under 100,000/cmm
- No mediastinal mass
- No CNS involvement
- Blast cells without B or N cell features

In T-cell ALL, relapse usually occurs within 2 years with the regimen given in Table 28.5. Patient may benefit considerably from bone marrow transplantation, or from measures-under-trial such as more intensive multidrug regimens, pugged autologous marrow before infusion, and adenosine deaminase inhibitor, deoxycoformycin.

In B-cell ALL, where prognosis is worst, chemotherapy has got to be more intensive though short (3 to 6 months). With the very intensive regimen (same as for advanced B-cell lymphoma), cure rates have dramatically shot up to 75% from the earlier 20% or

Table 28.5: Currently recommended treatment regimen for low-risk ALL

Remission Induction Chemotherapy (4 to 6 weeks)

This is achieved by intensive systemic chemotherapy.

Vincristine	1.5 mg/m ² (maximum 2 mg) IV once a week
Prednisolone	40 mg/m ² (maximum 60 mg) orally daily
Asparaginase	10,000 Units/m ² /day IM biweekly

Intrathecal CNS Prophylaxis with Triple Therapy

Methotrexate (MTX)		
Under 1 year	10 mg	Once a week during induction and then every 8 week for 2 years
2 to 8 years	12.5 mg	
Over 9 years	15 mg	
Hydrocortisone (HC)		
Under 1 year	10 mg	
2 to 8 years	12.5 mg	
Over 9 years	16 mg	
Cytosine arabinoside		
Under 1 year	20 mg	
2 to 8 years	25 mg	
Over 9 years	30 mg	

Systemic Continuation/Maintenance Therapy

6 MP	50 mg/m ² /day orally
MTX	20 mg/m ² /week orally, IV, IM

Pulse of MTX ± 6 MP given at higher doses

This therapy is continued for 2.5 to 3 years

Reinforcement/Late Intensification Therapy

Vincristine	1.5 mg/m ² (maximum 2 mg) IV every 4 weeks
Prednisolone	40 mg/m ² /day orally for 7 days every 4 weeks

so. Bone marrow transplantation should seriously be considered.

Administration of recombinant human granulocyte-macrophage colony stimulating factor (G-CSF), available as Leucomox, 5 to 10 mcg/kg/day (SC) for 7 to 10 days beginning after the remission-induction chemotherapy is just over, or until the postnadir neutrophil count is 1,000/cmm or higher for 2 days may benefit some cases.

As and when relapse occurs, irrespective of the type of standard-risk or high-risk ALL, it is in the form of CNS leukemia and/or testicular enlargement. This is an indication for irradiation, intensification of systemic treatment and CNS therapy.

ANLL Over 70% of the cases show remission with cytosine arabinoside continuous IV infusion for 7 days and IV daunorubicin for 3 days. Maintenance therapy is with rotating combinations of several drug for up to 2 years. CNS prophylaxis (IT) is indicated.

In M3 type of ANLL, fatal hemorrhage from DIC is expected. Heparin therapy is, therefore, needed.

CML Treatment consists in giving hydroxyuria or busulfan (the former is far better) to keep TLC under 100,000/cmm so that increased viscosity of blood and cerebrovascular accidents are avoided, splenic radiation, interferon and bone marrow transplantation.

In juvenile type, treatment is on the lines of that of ANLL. Results are, however, discouraging.

Congenital leukemia For control of high TLC, single agent chemotherapy, and for control of bleeding, platelet transfusions are sufficient. Spontaneous remission in the first few weeks is possible.

Prognosis

In the standard-risk or null-cell ALL, remission occurs in 95%; 75% remain in remission for at least 5 years, and majority are cured.

In B-cell ALL, 95% do attain remission but only 60% are able to maintain it beyond 5 years. Cure is rare.

In T-cell ALL, cure may occur in only a minority of the sufferers.

In ANLL, 30 to 40% subjects may be cured. In CML, no recorded cure is known as at present.

Among the factors contributing to relatively poorer prognosis in India are:

- Poor compliance/high dropout rate because of financial burden
- High incidence of superadded infections
- Lack of availability of good supportive care
- Poor tolerance of chemotherapy by malnourished children
- High component of T-cell leukemia and cytogenetic abnormalities (known for poor outcome) in Indian children with ALL.

LYMPHOMAS

The term, *lymphomas*, refers to a group of disorders in which there is a dominant malignant involvement of the lymphoid tissue with progressive pallor and pyrexia.

Currently, two major types of lymphomas are recognized, namely:

- Hodgkin disease
- Non-Hodgkin disease.

The two types have almost entirely different clinical presentations, treatment and prognosis and, therefore qualify for independent descriptions.

HODGKIN'S DISEASE

The disease is uncommon in childhood. It is however, known to have occurred at as young an age as 3 years. Peak incidence in childhood is seen in adolescence around 15 years of age.

Etiopathology

Hodgkin lymphoma is twice as common in boys as in girls.

It has occurred in like-sex siblings.

It has postulated that some viral etiology may well be in operation in causation of Hodgkin disease.

The lymphoma arises in T-dependent areas of the lymphoid tissue. The so-called *Reed-Sternberg cell* is the central histological feature. The origin of the cell appears to be from an antigen presenting-cell of the mononuclear phagocytoreticulum cell lineage, possibly from interdigitating reticulum cell.

Depending on the histological features, Hodgkin disease has been classified into four types as shown in Table 28.6.

Table 28.6: Histological types of Hodgkin disease

Types	Features	Relative frequency
Lymphocyte predominance	Abundant stroma of mature lymphocytes, histiocytes, or both; no necrosis, <i>Reed-Sternberg cells</i> sparse	10 to 15%
Nodular sclerosis	Nodules of lymphoid tissue partially or completely separated by bands of doubly retractile collagen of variable width; atypical <i>Reed-Sternberg cells</i> in clear spaces, lacunae in lymphoid tissues	20 to 50%
Mixed cellularity	Usually numerous <i>Reed-Sternberg</i> and atypical mononuclear cells with a pleomorphic admixture of plasma cells, eosinophils, lymphocytes and fibroblasts; foci of necrosis commonly seen	20 to 40%
Lymphocyte depletion	<i>Reed-Sternberg</i> and malignant mononuclear cells usually, though not always, numerous; marked paucity of lymphocytes; diffuse fibrosis and necrosis may be present.	5 to 15%

Remember that the types most commonly seen in pediatric practice are “nodular sclerosis” and “mixed cellularity”, the former in the second decade whereas the latter in the first decade of life.

Clinical Features

Painless enlargement of lymph glands, usually unilateral cervical, is the commonest presenting feature. The involved glands are usually matted, firm or rubbery, nontender and mobile (Fig. 28.5).

With progression of the disease, deeper glands may also be involved. They may cause symptoms by compression on other structures. Chronic whooping type of cough and manifestations due to mediastinal compression in the form of respiratory distress are well known.

4 Hodgkin disease may involve any organ besides lymph glands, causing corresponding manifestations (Fig. 28.6).

General symptoms include fever, anorexia, loss of weight, night sweats and pruritus. The so-called *Pel-Ebstein fever* occurs only in a small proportion (10 to 15%) of the cases. Ingestion of alcohol may cause abdominal pain.

Table 28.7 gives the clinical staging of the disease.

Table 28.7: Ann Arbor clinical staging system for Hodgkin's disease

Stage	Characteristics
I	Involvement of a single lymphatic gland region (I) or a single extralymphatic organ or site (IE)
II	Involvement of two or more lymph gland regions on the same side of the diaphragm (II) or localized involvement of an extralymphatic organ or site (IIE)
III	Involvement of glands in regions on both sides of diaphragm (III) or localized involvement of an extralymphatic organ or site (IIIE) or spleen (IIISE)
IV	Diffuse or disseminated involvement of one or more extralymphatic organs with or without associated lymph gland involvement. The organs involved should be identified by a symbol.

a = Asymptomatic

b = Fever, sweating, weight loss above 10% of body weight.

Diagnosis

The most reliable investigation is an histological examination of a biopsy from the involved lymph node.

X-ray studies are of value to evaluate the glands in the mediastinum and abdomen.

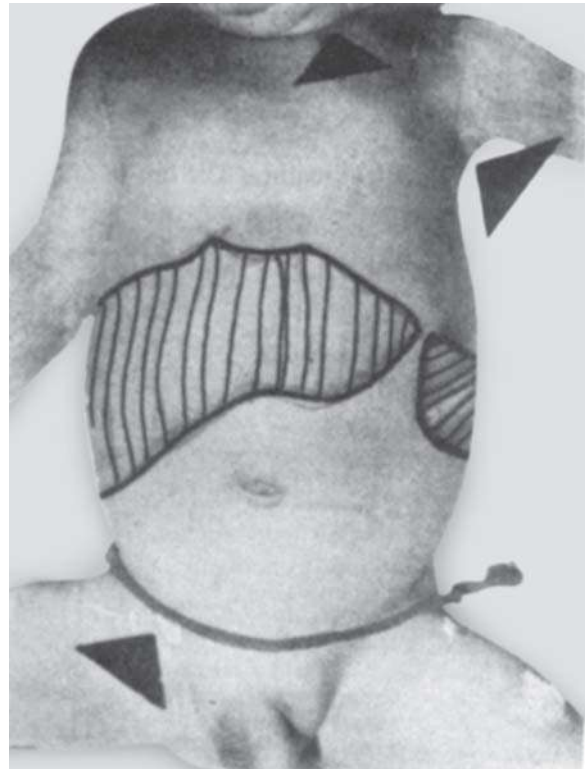

Fig. 28.5: Hodgkin's disease. The child presented with generalized lymphadenopathy, hepatosplenomegaly and mild ascites



Fig. 28.6: Hodgkin's disease. Note the matted, mobile and nontender cervical lymphadenopathy

Hematologic investigations usually show anemia, high ESR and eosinophilia. Bone marrow should be done to exclude its involvement.

Once diagnosis has been reached, laparotomy is a rule in almost all cases. At laparotomy, several abdominal lymph gland biopsies, liver biopsy and splenectomy are done.

Treatment

Today the treatment of choice is a combination of irradiation and aggressive chemotherapy.

- Stage Ia or IIa : Field irradiation or
Irradiation of clinically involved areas plus chemotherapy
- Stage Ib or IIb : Field irradiation followed by 6 months chemotherapy
- Stage IIIa : 3 cycles of chemotherapy, then total gland irradiation followed by chemotherapy for a total of 9 months
- Stage IIIb or IV : 12 courses of chemotherapy plus irradiation to areas of bulk disease.

Two widely-accepted chemotherapy regimens are: *MOPP* employing mustard (nitrogen mustard), oncovin (vincristine), procarbazine and prednisone; or *COPP* employing cyclophosphamide, vincristine, procarbazine and prednisone and *ABVD* employing adriamycin (doxorubicin), bleomycin, vinblastine and dacarbazine.

Prognosis

With modern treatment employing both chemotherapy and radiation, prognosis has considerably improved.

A large majority of the children with stages I and II are cured.

About 75% of children in stage III are cured. Over 50% of children in stage IV are cured with intensive chemotherapy. Complications of the treatment are:

1. *From Irradiation*
 - restriction of lung capacity
 - cardiac involvement
 - late hypothyroidism
 - retardation in growth of the vertebral column
 - sterility
 - premature menopause
 - retardation in growth of breasts
2. *Chemotherapy*
 - late pulmonary toxicity (bleomycin)
 - late cardiac toxicity (doxorubicin)
 - sterility in the male (MOPP)
3. *Surgery*
 - overwhelming sepsis
 - abdominal adhesions
 - secondary malignancy (leukemia)

NON-HODGKIN LYMPHOMA

The entity includes a diverse group of malignancies involving the lymphoid organs.

Etiopathology

Burkitt's lymphoma, also called African lymphoma, predominantly a disease of Central Africa and Uganda, seems to be secondary to Epstein-Barr virus (EBV) though herpes group virus and Reovirus type 3 have also been incriminated. An insect vector—possibly a mosquito—plays a role in its transmission.

The role of immunologic disturbances in the causation of non-Hodgkin lymphoma is currently receiving attention.

Clinical Features

Acute abdomen is the commonest presentation since the single most frequent site of origin of lymphoma is the lymphoid tissue of the GIT, usually in the ileocecal region.

Extra-abdominal presentation is generally in the form of nontender enlargement of the lymph nodes. Manifestations due to compressions, including that of mediastinum and spinal cord, are common.

Presenting features of Burkitt's lymphoma include jaw tumors, abdominal lumps and proptosis. Lymphadenopathy is conspicuous by its absence.

Table 28.8 gives the clinical staging of the non-Hodgkin lymphoma.

Table 28.8: St Jude's clinical staging system for non-Hodgkin lymphoma

Stage I	One single site
Stage II	Two or more sites on the same side of the diaphragm
Stage III	Disseminated disease without involvement of bone marrow or CNS
Stage IV	Any of the above with involvement of bone marrow or CNS

Diagnosis

Clinical and laboratory work-up of the case should be on similar lines as for Hodgkin's disease (Table 28.9).

However, it is a must to do lumbar puncture in each and every case.

Routine laparotomy and splenectomy are not needed.

Table 28.9: Laboratory workup in non-Hodgkin lymphoma

- Complete blood count (CBC)
- Serum electrolytes, including uric acid, lactate dehydrogenase, creatinine, calcium and phosphorus
- LFT
- Chest X-ray and CT scan
- Abdominal and pelvic ultrasonography/ CT scan
- Bone scan/gallium scan
- Bone marrow (both aspiration and biopsy)
- CSF (cytology in particular)

Treatment

The treatment of choice is a combination of irradiation and aggressive chemotherapy. The use of methotrexate and cranial irradiation prior to clinical involvement of the CNS is presently strongly advocated.

For localized nodal disease (stage I), treatment of choice is on the lines of ALL. However, only 1-year course is recommended.

For B-cell type (Burkitt lymphoma histology), a combination of high dose methotrexate and cyclophosphamide is recommended. It should be intensive therapy given for only 1 year.

For primary intrathoracic tumors in stage III, best cure rate is obtained with intensive 10-drug regimen.

A T-cell lymphoma requires CNS prophylaxis with chemotherapy, irradiation or both with a maintenance for 1 year.

Prognosis

Lymphoma with isolated glandular or intestinal involvement, provided that mediastinum is spared, has a good prognosis. Relapses with involvement of marrow and CNS are quite uncommon once the disease has been brought under control for 2 years or more.

Response of Burkitt lymphoma to chemotherapy (methotrexate for early and cyclophosphamide for advanced stage) is extremely favorable. Radiation and surgical excision of 90% of the tumor mass improve the remission and disease-free survival.

Cure rate in stages I and II is 90% and in stages III and IV 50%.

In subjects who had a relapse, use of intensive chemotherapy followed by autologous marrow reinfusion of identical twin marrow transplantation may prove of value.

Prognosis is worse in situations where bone marrow involvement and/or leukemic conversion has occurred.

WILMS' TUMOR (*Nephroblastoma*)

It is by and large next only to neuroblastoma in frequency of occurrence among the solid tumors of infancy and childhood (Fig. 28.7).

Embryonal in origin, this tumor develops within the kidney parenchyma, distorting it and invading the surrounding tissues. Existence of certain congenital anomalies predisposes to its development (Table 28.10).

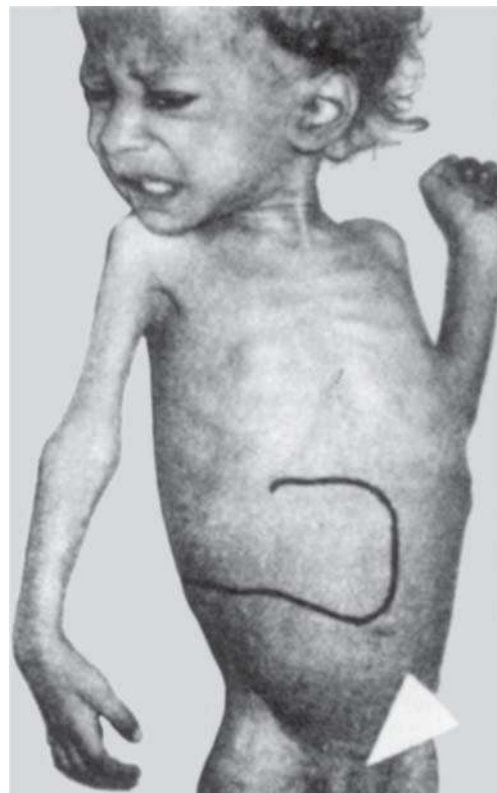

Fig. 28.7: Wilms' tumor

Table 28.10: Accompaniments of Wilms' tumor

- Ambiguous genitalia
- Undescended testes
- Hypospadias
- Duplication of ureter or kidney
- Horse-shoe kidney
- Aniridia
- Hemihypertrophy
- Beckwith syndrome

Clinical Features

The most important presenting feature is a large unilateral abdominal mass (see Fig. 28.5). Often, it is detected by the doctor on routine examination. But, more frequently, it is noticed by the parents while dressing or undressing the child. Pain abdomen is infrequent. Hematuria is rare.

If metastases has occurred, associated symptoms will be seen depending on the organ(s) involved. Almost half of the sufferers older than 2 years show metastases. About one-fourth under 2 years too have some metastases.

Once in a while the tumor may rupture from injury. In such a situation, the child presents as an acute surgical emergency.

Bilateral tumor is infrequent, the incidence being just 2%.

Table 28.11 presents clinical staging of Wilm's tumor.

Table 28.11: Clinical staging for Wilms' tumor (NWTS Group)

Stage I	: Limited to the kidneys; can be fully excised with capsular surface intact
Stage II	: Extends beyond the kidney but can be fully excised
Stage III	: Residual nonhematogenous extension of the tumor, confined to the abdomen following surgery
Stage IV	: Hematogenous metastases, most frequently involving the lung
Stage V	: Bilateral kidney involvement in 5 to 10% cases

Diagnosis

As soon as Wilms' tumor is clinically suspected, take a plain X-ray film of abdomen. It shows a soft tissue opacity displacing the gut in the area normally occupied by the kidney.

An IV pyelography showing distortion of calyces by a mass within the kidney confirms the diagnosis.

Urinalysis may reveal hematuria.

Bone marrow may rarely show metastases.

Chest X-rays should also be taken to detect any metastases in the lungs.

Treatment

If the tumor is grossly resectable, especially in a child under 2 years of age, treatment consists of surgery plus actinomycin-D and vincristine over several months.

In the event of metastases or extensive local extension, irradiation is added to the surgery and chemotherapy is given for longer periods. Addition of doxorubicin to chemotherapy gives yet more favorable results.

For stage IV, radiotherapy and combination therapy with 3 or more drugs for 15 months is currently recommended.

Preoperative therapy is recommended only in stage V to cause shrinkage of the primary tumor so that partial nephrectomy, salvaging as much residual normal kidney as possible, could be carried out.

Prognosis

With aggressive treatment, 75 to 90% 2-year disease-free survival rate has been attained.

Prognosis is better when Wilms' tumor is diagnosed before the age of 2 years and when its weight is under 250 g. Recurrence carries bad prognosis.

NEUROBLASTOMA

It is a malignant tumor arising from sympathetic ganglia or adrenal medulla.

The common locations of neuroblastoma are the abdomen and chest.

Early metastases constitutes the hallmark of the disease.

Clinical Features

The peak incidence occurs at 2 to 3 years of age. It is rare to encounter it after the age of 6 years. Of course, there are recorded cases at any time from neonatal period to adolescence. Familial occurrence is recorded; so is the occurrence in identical twins.

The commonest presenting feature is a palpable mass in the abdomen. The mass is hard, fixed, crosses the midline and pushes the kidney upwards.

The rest of the manifestations depend on the extent of the disease. Fever, bone pain, anemia and loss of weight are common presenting complaints. Subcutaneous nodules, adrenal masses with involvement of the marrow, hepatomegaly from massive infiltration of liver, paraplegia, paroxysmal hypertension, and proptosis secondary to retro-orbital deposits are the other manifestations.

Evans clinical staging of neuroblastoma is given in Table 28.12.

Table 28.12: Evans clinical staging system for neuroblastoma

Stage I	Tumor confined to organ or structure of origin
Stage II	Tumor extending in continuity beyond organ or structure of origin but not crossing the midline; regional nodes on homolateral side may be involved
Stage III	Tumor extending in continuity beyond the midline; original nodes may be involved bilaterally; bilateral extension of midline disease
Stage IV	Remote disease involving selection, organs, soft tissue, distant nodes, and so on
Stage V	Patients who would otherwise be stage I or II, i.e. with small and/or resectable primary tumor, but who have remote disease confined only to one or more of the following sites: liver, skin or bone marrow (not bone)

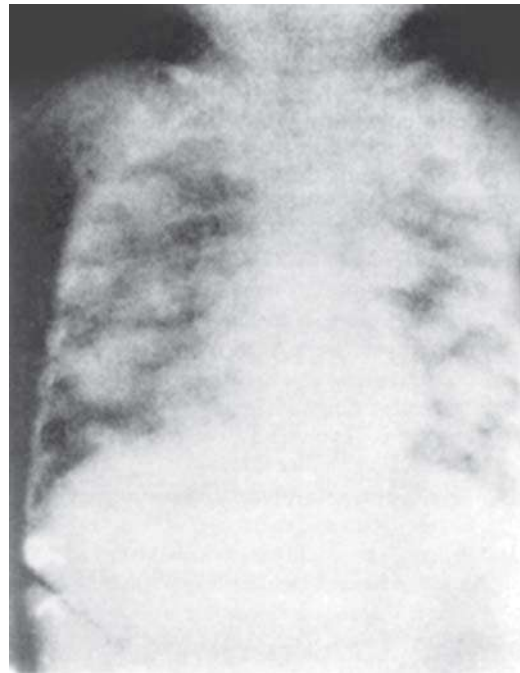
**Fig. 28.8:** Secondaries in lungs from neuroblastoma

4 Diagnosis

X-ray studies reveal displacement of one of the kidneys by a suprarenal mass and/or a paravertebral shadow or a tumor in the posterior mediastinum. Gross skeletal metastases may also be detected (Fig. 28.8).

CT scan is the best for abdominal tumor, and of considerable help in defining the extent of intraspinal extension.

Urine examination reveals an excess excretion of catecholamine and/or their metabolites, vanilmandelic acid (VMA), and cystythyionine.

Bone marrow may show secondary deposits, i.e. neuroblasts, which may simulate leukemia.

Treatment

Treatment involves a combined application of surgery, irradiation and chemotherapy with drugs like vincristine, cyclophosphamide, decarbazine and doxorubicin. VM26, epipodophylotoxin, or cisplatinum.

Since most tumors have had dissemination at the time of diagnosis, chemotherapy is the cornerstone of treatment. With the following two regimens, 50% of the patients undergo remission:

1. Cyclophosphamide
Doxorubicin
2. VM26
Cisplatinum
Epipodophylotoxin

Response to bone marrow transplantation, autologous marrow reinfusion after purging with cyclophosphamide derivatives, is being studied.

Prognosis

Age has considerable bearing on the prognosis. If diagnosed after the age of 2 years, death occurs rapidly in over 80% of the cases despite adequate therapy.

Around 80% or more 2-year disease-free survival with therapy has been reported under one year of age.

Spontaneous cure has also been on record. Serial measurement of VMA in urine provides a good index of response to therapy.

HEPATOBLASTOMA

Though quite infrequent, hepatoblastoma is still relatively more common than the other primary tumor of the liver, i.e. hepatocarcinoma (hepatoma). It usually occurs in male children under 3 years of age and involves predominantly the right lobe of the liver. Boys and girls ratio is 1.5: 1.

Manifestations include noticeable abdominal distention with or without pain, anorexia, weight loss, anemia, fever and fatigue. Less frequent manifestations are vomiting, jaundice and, in boys, virilization. Hepato-megaly with or without a definable tumor mass is present (Fig. 28.9).

Liver function tests are only slightly affected. Cystathionuria and raised alpha-fetoglobulin may be demonstrated.

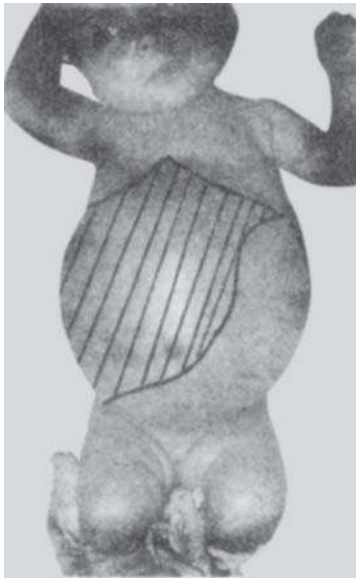

Fig. 28.9: Hepatoblastoma

Plain X-ray abdomen and IVP assist in establishing intrahepatic origin of the lump.

Specialized techniques such as scans, angiography and computerized tomography may be of considerable help in the diagnostic work-up.

Liver biopsy may be done but the final tissue diagnosis should be made at laparotomy.

Treatment is radical excision of the involved lobe and isolated lung metastasis. Chemotherapy (cisplatin, vincristine, adriamycin) has a temporary, beneficial effect.

Prognosis, as a rule, has so far been disappointing. Mortality rate is 65%. Liver transplantation may improve prognosis.

BRAIN TUMORS

Next to leukemias, brain tumors constitute the most common malignancy of childhood. A vast majority of them are infratentorial and close to midline. Hence, hydrocephalus is a common finding. Vomiting, headache, papilledema, ataxia, diplopia and personality changes in the form of behavior problems, speech disturbances, irritability and decline in intellect are other frequent accompanying manifestations. Skull X-ray often shows sutural diastasis and silver-beaten appearance (Fig. 28.10). Computerized tomography (CT scan) has been a tremendous advance in localization of the brain tumors.

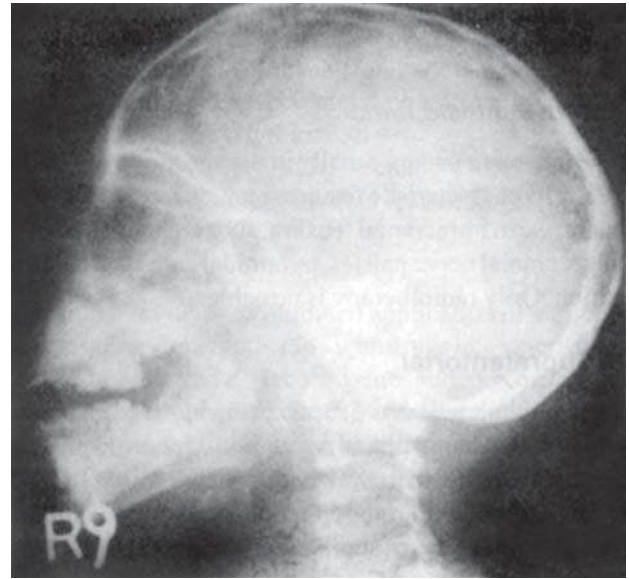

Fig. 28.10: Skull X-ray, showing silver-beaten appearance in a child with brain tumor

Infratentorial

Cerebellar Tumors

Astrocytoma occurs in 3 to 8 years age group and is characterized by unilateral cerebellar signs such as ataxia, nystagmus, hypotonia, areflexia and tilting of the head to the side of the lesion. It is relatively slow growing and is amenable to surgical excision.

Medulloblastoma (Figs 28.11 and 28.12) occurs in 3 to 5 years age-group, most often in boys. Ataxia, usually truncal, is severe and common. It is rapid growing and highly malignant. Treatment is in the form of irradiation, surgery and chemotherapy.

Brainstem Tumors

Pontine glioma (Fig. 28.13) occurs in 6 to 8 years age group. Bilateral multiple cranial nerve involvement (usually sixth and seventh), ataxia, pyramidal signs and absent or minimal signs of raised intracranial tension are its characteristic features. It is fast growing and amenable to irradiation.

Fourth Ventricle Tumor

Ependymoma occurs usually in the age group of 7 to 10 years. Its characteristic features include local extension, early rise in intracranial tension, subarachnoid hemorrhage, cranial nerve palsies, pyramidal signs and calcification. Only radiotherapy is possible.

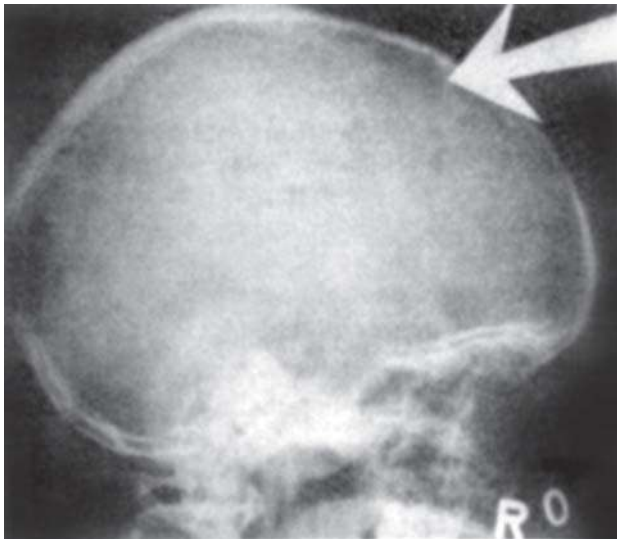

Fig. 28.11: Intracranial space-occupying lesion (medulloblastoma). Note the sutural diastasis



Fig. 28.13: MRI of a solid brainstem glioma which is the third most common posterior fossa tumor of childhood



Fig. 28.12: CT scan showing medulloblastoma which is the most common posterior fossa tumor after astrocytoma (cerebellar) and the most common in under age 7 years

Supratentorial

These include *gliomas* of optic pathway, hypothalamus and cerebral hemisphere, *papilloma* of choroid plexus, *ependymoma* of cerebral hemisphere, *dermoid* and *teratoma* of midbrain and craniopharyngioma. Common presenting features of supratentorial tumors are convulsions and hemiparesis.

Craniopharyngioma originates from cell rests of Rathke pouch and occurs at all ages. Clinical features

include raised intracranial tension, growth failure with dwarfism, bitemporal hemianopia, visual field loss, diabetes insipidus, delayed puberty, calcification in suprasellar or sellar region and ballooning of sella in X-ray skull. The tumor is frequently benign. Treatment is surgical excision with hormonal therapy, or drainage of the cyst and radiotherapy.

BONE TUMORS

Bone tumors in children, almost always either osteosarcoma or Ewing sarcoma (the latter is by and large limited to white population), have a tendency to occur in adolescents rather than young children. Chondrosarcoma is rare in children.

Osteosarcoma

Osteosarcoma characteristically occurs during the adolescent spurt (the mean age being 15 years) and involves metaphyseal ends of long bones like femur, tibia, and humerus. Predisposing diseases include retinoblastoma, multiple osteochondromatosis (Ollier disease), multiple hereditary exostosis, osteogenesis imperfecta, Paget disease, and Ewing tumor.

Manifestations include pain at the site of the tumor, localized swelling and warmth, limitation of movements, limp, tenderness and erythema. Metastasis may lead to respiratory embarrassment, pleural effusion, pneumothorax and other signs and symptoms depending on the sites.



Fig. 28.14: Shows alopecia secondary to chemotherapy for brain tumor

Diagnosis should be suspected in every patient with unexplained bone pain in association with a palpable mass. X-ray shows sclerosis and new bone formation. CT scan of the affected bone delineates the magnitude of the medullary involvement. CT scan of the chest becomes mandatory particularly in cases where no metastases has been seen on chest X-ray.

Treatment is radical surgery followed by aggressive chemotherapy employing high dose methotrexate, **cisplatin, doxorubicin, bleomycin, cytoxan, and dactinomycin**. This provides 80% disease-free survival compared to just 20% with surgery alone. On an average, 50 to 60% survival is reported (Fig. 28.14).

Ewing Sarcoma

Ewing tumor characteristically occurs in later childhood and adolescence, involving either long bones of extremities (most often femur) or flat bones of head and trunk. It is rare in nonwhite races.

Manifestations include painful swelling with constitutional symptoms like fever and malaise. This presentation may well initially give the clinician an impression of osteomyelitis or eosinophilic granuloma.

Diagnosis even though supported by X-ray showing mottled, lytic, onion-skin pattern, must be confirmed by surgical bone biopsy showing round cell tumor. CT scan is required to define the magnitude of the tumor. For lung metastases, chest X-ray and CT scan, for bone metastases, radionuclide bone scan, and for bone marrow metastases, marrow biopsy are needed.

Treatment consists of high dose irradiation of the primary tumor site and combination of chemotherapy employing vincristine, cyclophosphamide, dactinomycin, and doxorubicin.

With metastases, survival is 5 to 15%. Without metastasis it is around 60%.

SOFT TISSUE SARCOMAS

Rhabdomyosarcoma is the commonest among the multitude of soft tissue sarcomas in various tissues of origin (examples: primitive mesenchyma-malignant mesenchymoma; adipose-liposarcoma; fibrous-fibrosarcoma; lymphatic-lymphangiosarcoma; blood angiosarcoma; synovium-synovial cell sarcoma; smooth muscle-desmoid; striated-muscle rhabdomyosarcoma).

The tumor shows an early peak before 5 years and a later peak around 15 to 19 years of age. In the first peak, head, neck, prostate, bladder and vagina are involved. In the second peak, genitourinary tract is the major site. Neurofibromatosis and cancer families predispose to rhabdomyosarcoma.

Manifestations include a lump (that may be painful) with complaints referable to the organ/system involved. For instance, if the location is nasopharynx, manifestations may be nasal congestion, mouth-breathing, epistaxis and swallowing and chewing difficulties. Involvement of the larynx causes croupy cough and progressive stridor. In orbital involvement, there is proptosis, ptosis, periorbital edema, change in visual acuity and local pain. A rapidly growing scrotal mass may mean paratesticular tissue involvement. Because of early metastasis, bone and lung symptoms are common denominators of rhabdomyosarcoma in any location.

Diagnosis is confirmed by X-ray and CT scan studies as well as tumor tissue and bone marrow.

Treatment varies with the IRS (International Rhabdomyosarcoma Study) staging as shown in Table 28.13.

Rhabdomyosarcoma in locations which are parameningeal, irrespective of group, is an indication for intrathecal therapy.

With suitable treatment, 80 to 90% subjects have tumor-free survival in Groups I and II. In Groups III and IV, it is 60 to 65%. In older children, prognosis is worse than in younger children.

RETINOBLASTOMA

This rare tumor, though the commonest ocular neoplasm of childhood, usually develops in the

Table 28.13: IRS staging and treatment of rhabdomyosarcoma

Group Features	Treatment
I Localized disease; regional nodes not involved; completely removable	Complete local excision with chemotherapy
II Grossly resected tumor with regional nodes involved on microscopic residual disease	Surgery followed by local irradiation and chemotherapy
III Gross residual disease	Same as for group II
IV Distant metastatic disease	Chemotherapy

posterior portion of the retina. About 70% subjects have unilateral (Fig. 28.15) and 30% bilateral disease. Average age for unilateral disease is 26 months and for bilateral disease 8 months. Around 90% of cases are less than 5 years of age.

4 All children with bilateral disease and 10 to 20% with unilateral disease have a genetic predisposition. The retinoblastoma gene is located on chromosome 13. This gene carries risk of osteosarcoma and a secondary malignancy like a pineal tumor, the so-called “trilateral retinoblastoma”.

Manifestations include leukokoria, yellow white reflex in the pupil, loss of vision, squint, pain, pupillary irregularity, or hyphema. In advanced cases, frank proptosis, raised intracranial pressure and bone pain may be present. Metastasis is rare.

Diagnosis is by demonstration of yellow white reflex on funduscopy in cases of leukokoria. CT scan is

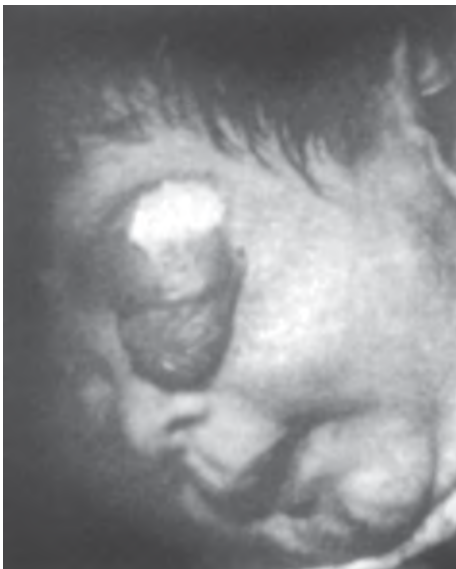

Fig. 28.15: Unilateral retinoblastoma

needed to determine extent of tumor as also if optic nerve and bony structures are involved. Other investigations should include a skeletal survey, radionuclide bone scan of the head, CSF, bone marrow, carcinoembryonic antigen and alphafetoproteins.

Treatment in unilateral disease is usually enucleation of the eye. In bilateral disease, attempt is made to save at least one eye with useful vision by radiotherapy. In gross or microscopic disease in the enucleated eye and in widespread metastatic disease, chemotherapy with cytoxan and doxorubicin should be considered.

With appropriate treatment, recovery in early diagnosed cases is 90 to 100%.

THYMOMA

This anterior mediastinal soft tissue tumor is rare in childhood. It rarely metastasizes outside chest.

Manifestations include compression symptoms like intractable cough, dyspnea, dysphagia and prominence of the vein of the chest wall and neck due to superior vena cava compression. Elevated production of suppressor lymphocytes by the tumor may cause imbalance in immune regulation, leading to such paraneoplastic syndromes as myasthenia gravis, pure red cell aplasia and hypogammaglobulinemia.

Though it is a radiosensitive tumor, the treatment of choice is complete surgical excision. Recurrences need to be treated with such chemotherapeutic agents as doxorubicin, cyclophosphamide, and cisplatin.

TERATOMAS

These are a kind of germcell tumors, occurring most often in infants (usually female) in sacrococcygeal region (Fig. 28.16).

Alpha-fetoprotein (AFP) may be normal or just slightly high. Significant elevation in this marker points to development of malignancy in the teratoma.

Risk of malignancy is 10% in infants under 2 months but 50% in those above 4 months.

Treatment is surgical excision. Cure rate is around 75-90%.

ONCOLOGIC EMERGENCIES

The term, *oncologic emergency*, is applied to an acute and potentially life-threatening event, directly or indirectly related to the neoplasm or its treatment.



Fig. 28.16: *Teratoma*. Resection revealed such varied contents as hair follicles, and dental, bony and visceral tissue

Table 28.14 lists the common types of oncologic emergencies.

Timely diagnosis and appropriate treatment of these oncologic emergencies can go a long way in reducing the oncologic morbidity and mortality.

BONE MARROW TRANSPLANTATION

Indications

This new therapeutic modality, now available in India, may be indicated in the following situations, provided that alternative therapeutic modalities are not able to offer reasonable chance for a cure or prolongation of survival.

1. Aplastic anemia
2. Acute leukemia
3. Immunodeficiency disease
4. Congenital hemolytic anemia—thalassemia major, sickle cell disease.

Procedure

An essential prerequisite is that the recipient must receive “conditioning” pretransplant immunosuppression with cyclophosphamide and low dose

Table 28.14: Common pediatric oncologic emergencies

Hematologic
Massive bleed with shock
Severe anemia
DIC
Hyperleukocytosis
Febrile neutropenia
Necrotizing enterocolitis (NEC)
Myelosuppression
Space-occupying
Superior vena cava syndrome (SVCS)/superior mediastinal syndrome (SMS)
Raised intracranial pressure (RICP)
Brain herniation
Pericardial effusion/Cardiac tamponade
Spinal cord compression
Massive hepatosplenomegaly
Metabolic
Syndrome of inappropriate ADH secretion (SIADHS)
Tumorlysis syndrome (TLS)
Hypercalcemia
<i>Inflammatory</i>
Neutropenic enterocolitis (typhilitis)

total body radiation to cut down risk of “graft rejection” or “graft-vs-host disease” (GVHD).

Bone marrow is obtained from multiple sites on the posterior iliac crest, using sterile technique, under general anesthesia. Just 200 ml is enough in children. It is filtered to obtain a single cell suspension and to remove particles that can possibly embolize to the lungs. The suspension is transfused intravenously to the recipient.

Hyperalimentation (parenteral) is advisable during the first month after transplant to prevent malnutrition and to improve survival. During this period, transplant patient frequently develops anorexia, nausea, vomiting and other symptoms related to GIT as a result of chemotherapy, radiation and graft-vs-host disease. He is particularly vulnerable to develop infection and bleeding during this period of severe bone marrow aplasia. Effective supportive measures are, therefore, mandatory.

Complications

The complications of the procedure include graft rejection, graft-vs-host disease (GVHD), infections (e.g. interstitial pneumonia) and recurrence of leukemia in acute lymphoblastic leukemia (ALL).

FURTHER READING

Articles/Chapters

1. Advani SH, Iyer SR, Venzon D. Acute lymphoblastic leukemia in India. An analysis of prognostic factors using a single treatment regimen. *Ann Oncol* 1999;10:167.
2. Arya LS: Oncologic emergencies. In. Gupte S (Ed): *Recent Advances in Pediatrics (Special Vol. 14: Criticare Pediatrics)*. New Delhi: Jaypee 2004:521.
3. Arya LS. Acute lymphoblastic leukemia. In Gupte S (Ed): *Recent Advances in Pediatrics- 10*. New Delhi: Jaypee 2000:159.
4. Kashyap B, Choudhry VP. Biological therapy of cancer. In Gupte S (Ed): *Recent Advances in Pediatrics-10*. New Delhi: Jaypee 2000:142.
5. Singh T. Oncologic emergencies: approach for the pediatrician. In Gupte S (Ed): *Recent Advances in Pediatrics-10*. New Delhi: Jaypee 2000:171.

Book/Monograph

1. Pizzo PA, Poplack DG. *Principles and Practice of Pediatric Oncology* Philadelphia: Lipincott Williams and Wilkins 2006.

CHAPTER



29

Pediatric Immunology

ML Kulkarni, Suraj Gupte, S Frank

INTRODUCTION

Conventionally speaking, *immunity* refers to the defence mechanism that protects an individual against invasion by an infection. Today, it is believed to have extended defence function, e.g. immunologic surveillance limits the development of tumor cells, malignant cell clones, moulds and grafts.

As shown in Figure 29.1, immunity may be *innate* or *acquired*. Innate immunity may be genetically passed on from one generation to another without depending on previous contact with a microbe. When it indicates a degree of resistance to all infections, it is termed *nonspecific*. When there is a resistance to a particular pathogen, it is called *specific*. Innate immunity is also expressed in relation to species, race or individual. Such factors as age, hormonal influences and nutrition considerably affect immune response.

IMMUNOLOGIC SYSTEM: FUNDAMENTALS

Immunologic system operates with involvement of lymphocytes, plasma cells and macrophages (Fig. 29.2).

Thymus and bursa of Fabricius (marrow in man) form the *central lymphoid tissues*. Spleen and lymph glands constitute the *peripheral lymphoid tissues*. Immunologic response has two stages:

- Phagocytic, and
- Lymphocytic

Phagocytic response consists in destroying the foreign agents (Fig. 29.3). The key cells involved in this response are neutrophils from the circulating blood and macrophages from the reticuloendothelial system, particularly the lymph glands and the spleen.

In the conduct of phagocytic response, additional factors such as complement and opsonin may be

required. If the invading agent is destroyed by phagocytosis, immune response stops here only. But, if antigenic products are produced, the next step, i.e. lymphocytic response, which is the sheet-anchor of the immunologic system, must follow.

Complement refers to a series of factors in the normal serum that are activated by antigen-antibody interaction and subsequently mediate a number of biologically significant consequences. It forms about 10% of human serum globulin. There are 9 distinct components of complement system, one of them having 3 subunits (C'1g' C'1r' C'1s') thereby making a total of 11 proteins. Chain of event in which complement components react in specific sequence following activation of antigen-antibody complexes and culminating in immune cytolysis is known as *classical C' pathway*. Activation of C'3' without prior participation of C'1' C'4' and C'2' is called *alternate pathway*. Activities of the complement immunity against infection may be outlined as under:

C'1' and C'4' C'1' C'4' C'2' and C'3': Neutralization of viruses

C'4a' C'3a' C'5a': Capillary dilatation C'5a': Chemotaxis of neutrophils, monocytes, eosinophils

C'3b': Opsonization, enhancement of cell-mediated cytotoxicity stimulation of production of B cells lymphokines

C'3b' C'3d': Increased induction of antibody formation

C'3c': Induction of granulocytosis

C'5': Opsonization of fungi

C'1' to C'6': Inactivation of endotoxin

C'1' to C'9': Lysis of viruses, virus-infected cells, tumor cells, mycoplasma, protozoa, spirochetes and bacteria.

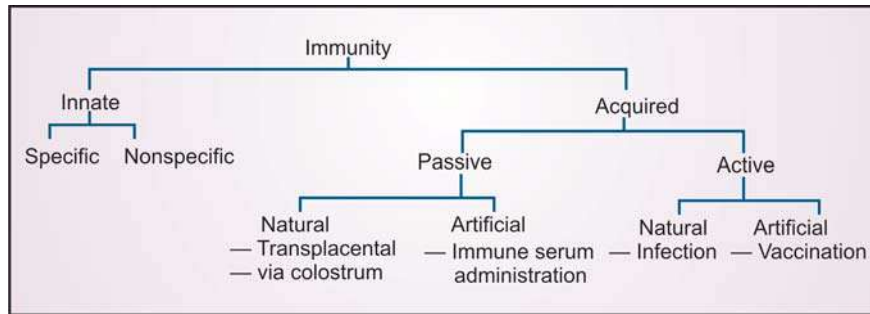

Fig. 29.1: Classification of immunity

CELLS	LEUKOCYTES									Other	
	Lymphocytes		Phagocytes			Auxiliary Cells			Platelets		Tissue cell
	B Cell	T Cell	Large	Mononuclear	Neutrophil	Eosinophil	Basophil	Mast cell			
Soluble mediators	Antibodies		Cytokines	Complement			Inflammatory Mediators		Interferon cytokines		

Fig. 29.2: Cells of the immune system

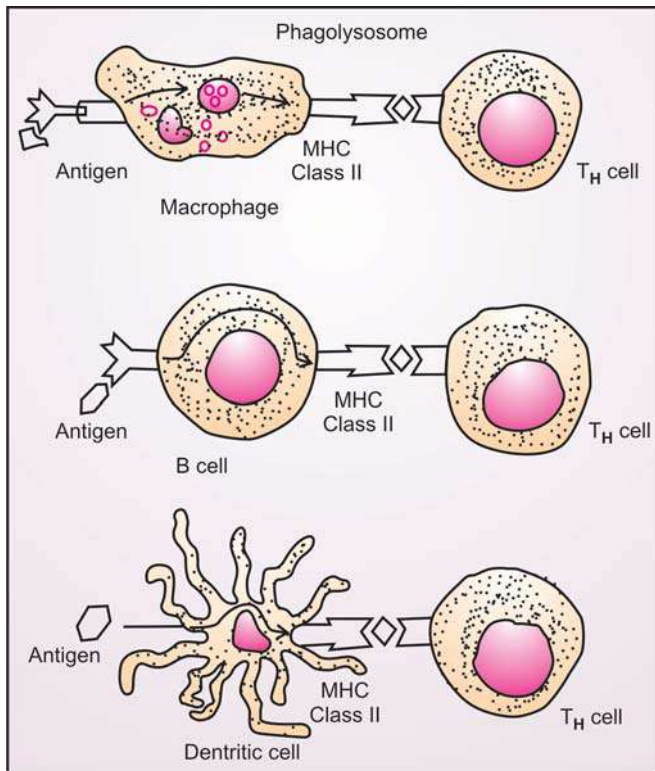

Fig. 29.3: Antigen presenting cells

Lymphocytic response is affected by either humoral or cellular mechanism, or both.

Humoral immunity is concerned with synthesis and release of antibodies (immunoglobulins) secreted by plasma cells, as also complement, interferon and lysozyme. Its functional cell is B-lymphocyte, the bursa-dependent cell, which stems from the precursor in the bone marrow.

About 25% lymphocytes are B cells. They are mostly restricted to lymphoid tissue. T helper cells are essential for their transformation into antigen recognition cells and production of immunoglobulins. T suppressor cells suppress the activity and lessen formation of antibodies. Thus, the immune response is maintained within a tolerable level.

On entry of an offending agent (antigen), B cells develop into plasma cells which secrete specific antibodies to antagonize the antigen. Once the illness is over, level of circulating antibodies falls slowly over a period of several weeks. In case the same illness returns, level of antibodies against the antigen rises rapidly, thereby halting the invasion by the same antigen and acquisition of specific immunity. This

happens since the body remembers the mechanisms by which the antibody was produced earlier. This is called *immunologic memory* (Fig. 29.4).

Functions of the B cells include:

1. Protection against *Staphylococcus*, *Streptococcus*, *Hemophilus*, *Pneumococcus*,
2. Neutralization of viruses to prevent initial infection,
3. Action as a barrier along gastrointestinal and respiratory tracts,
4. Active lysis of cells of autologous origin or engagement in antigen-antibody complex disease,
5. Interference with T killer cells activity, or directly or indirectly blocking the reaction.

Immunoglobulins (Figs 29.5 and 29.6) are the globulin molecules associated with antibody activity, extending in electrophoretic activity from alpha2 to gamma regions. Basically their structure consists of two polypeptide chains. First, i.e. light chain, may be kappa (κ) or lambda (λ). Second, i.e. heavy chain, imparts class specificity. Structurally, 5 major types are recognized at present—IgG, IgA, IgM, IgD and IgE.

IgG is the major immunoglobulin, constituting around 75% of the immunoglobulin content of the serum. In the fetus, it is by far the only immunoglobulin present. The newborn receives it, by transport across the placenta, in sufficient amount depending on the gestational age, weight and efficiency of placental function. IgG so received from

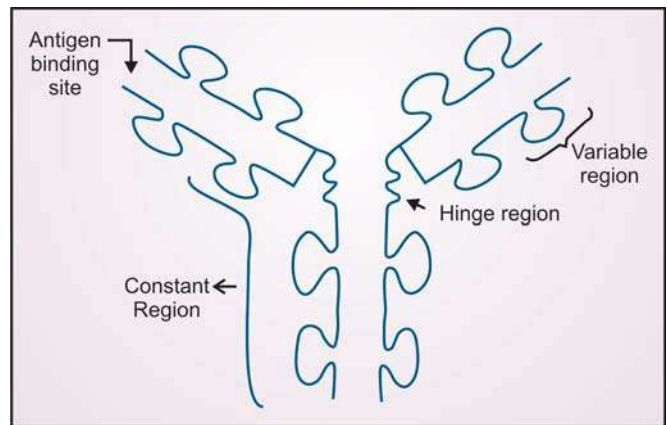

Fig. 29.5: Structure of immunoglobulin

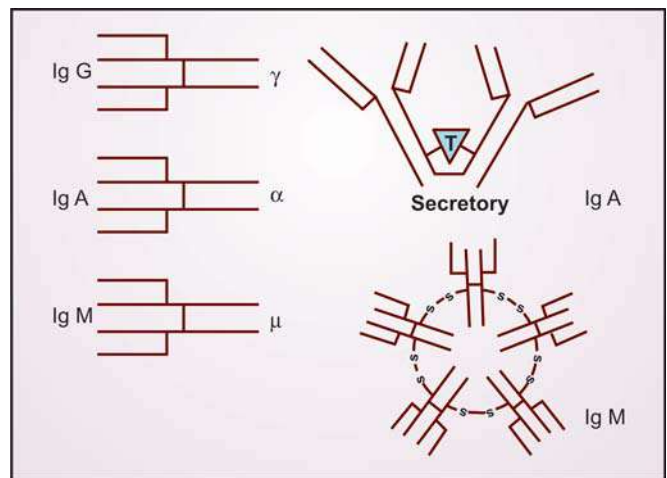

Fig. 29.6: Structure of IgG, IgA and IgM

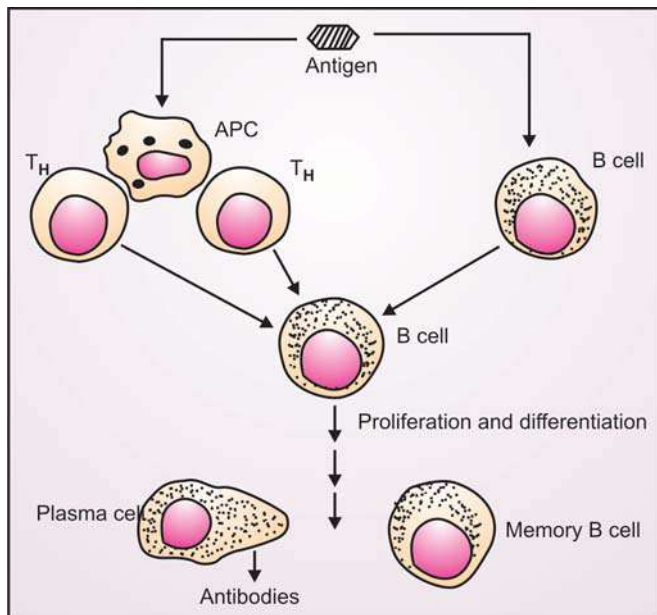

Fig. 29.4: B cell activation and antibody formation

the mother gradually begins to fall after birth so that at 2 to 6 months the infant suffers from what is known as physiological hypogammaglobulinemia G which is discussed later in this very Chapter. There are further subclasses of IgG, say IgG1, IgG2, IgG3, and IgG4, based on differences in heavy polypeptide chain (Fc).

IgA and IgM are very low at birth, the adult levels reaching by the age of 2 years. The exact role of IgM in immune response is not yet clearly understood. IgA is, however, well known to play an important part in human defence against infection, particularly pertaining to respiratory tract and gastrointestinal tract. Agammaglobulinemia is always accompanied by deficiency of secretory component of IgA (Table 29.1).

Cell-mediated immunity (CMI) is affected by its functional cell, T lymphocyte, which is thymus-dependent and initially stems from the precursors in

Table 29.1: Properties of immunoglobulins

Properties	IgG	IgA		IgM	IgD	IgE
		Serum	Secretory			
Molecular weight	140,000	160,000	370,000	900,000	160,000	2000,000
Placental transfer	Yes	No	No	No	No	No
Complement fixation	Yes	No	Yes	Yes	No	No
Polymer formation	No	No	Yes	Yes	No	Doubtful
Blocking antibody	Yes	Doubtful	Yes	Doubtful	Doubtful	Doubtful
Secreted by mucous surfaces	Weak	Weak	Yes	Weak	No	Yes
Fixation to mast cell	No	No	No	No	No	Yes
Fixation to macrophages	Yes	No	No	No	No	No
Bactericidal function	Yes	No	No	Yes	No	No
Role	Protection of tissue fluid	Protection of circulation	Protection of mucosal surface	Protection of circulation	Unknown	Reaginic activity

4

the bone marrow as is the case with B lymphocytes. These cells form about 75% of the lymphocytes and mostly circulate in blood, interstitial space and lymph in the marrow. A recently described thymus hormone, *thymosin*, is claimed to maintain their activity. Functions of T lymphocytes include:

1. T helper function.
2. T suppressor function.
3. T killer function.
 - containment of acid-fast bacilli.
 - containment of certain viral infections (EBV, slow virus).
 - containment of fungal infections (candida).
 - containment of protozoal infections (*Pn carinii*).
 - rejection of allograft (tumors).
 - graft vs host disease (GVHD).
 - contact dermatitis.

Lymphokines are soluble mediator substances which are liberated when an antigen-sensitive T lymphocyte comes into contact with the specific antigen at the periphery. The major soluble factors include

- Mitogenic factor which enhances lymphocyte multiplication,
- Permeability increasing factor,
- Lymphocytotoxin,
- Migration inhibiting factor which favors phagocytosis, and
- Transfer factor which transfers to the uncommitted cells the characteristics of the antigen-sensitized cells.

Cellular immune response ends up in destruction of the antigen. This may either be directly through the

action of the sensitized lymphocytes or by activity of lymphocytotoxins.

IMMUNODEFICIENCY STATES

By immunodeficiency is meant that one or more defence mechanisms is impaired or lacking. It may be *primary* when there is no obvious systemic disease to explain its occurrence. In the *secondary* type, the cause is clearly outside the lymphoid system, e.g. protein-energy malnutrition, malignancy, infections, drugs, etc. The immune mechanism is affected either as a part of generalized disease process or due to influence of certain aspect of the primary disease involving the lymphoid system.

Primary deficiency is far less than the secondary deficiency (Fig. 29.7). Box 29.1 lists various modes of presentation of immunodeficiency.

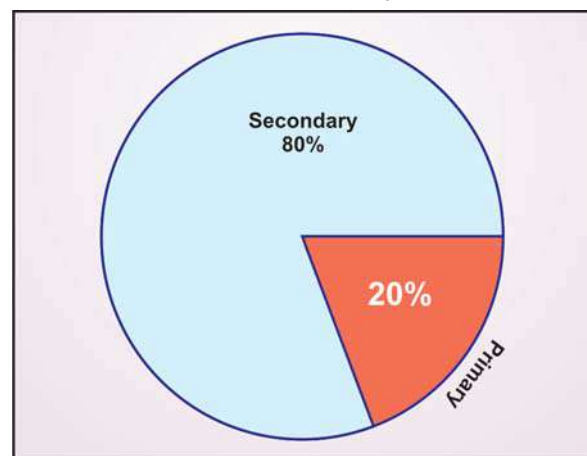

Fig. 29.7: Relative frequency of primary and secondary immunodeficiency

Box 29.1: Modes of presentation of immunodeficiency

1. Recurrent infections: *Pneumocystis carinii*, *Aspergillus fumigatus*, subacute sclerosing panencephalitis (SSPE).
2. GIT upset in the form of unexplained protracted diarrhea/malabsorption, recurrent infestation with *L. giardia*.
3. Recurrent eczema without any obvious cause.
4. Failure to thrive which is difficult to explain.
5. Unusual vaccination reactions, e.g., infection after BCG
6. Autoimmune disorders, e.g. rheumatoid arthritis.
7. Malignancy, e.g. leukemia.
8. Disorders of parathyroids and thymus associated with developmental anomalies of face, e.g. hypocalcemic tetany.
9. Ataxia telangiectasia, characterized by hereditary cerebellar ataxia and conjunctival telangiectasia together with frequent sinopulmonary infections.
10. Hereditary angioneurotic edema.
11. Nutritional deficiency state, e.g. protein-energy malnutrition, iron deficiency anemia.

I. PRIMARY IMMUNODEFICIENCY STATES

Table 29.2 gives classification of primary immunodeficiency.

B-Cell Defects

Clinical manifestations of B-cell (humoral immunity) defects include recurrent bacterial pneumonia, sepsis, septicemia, meningitis and nodular lymphoid hyperplasia.

Physiologic hypogammaglobulinemia G is a self-limiting condition, occurring at 3 to 6 months of age when the maternal IgG is depleted and yet the infant has not been able to synthesize enough IgG to make up for the loss. Infants of low birth-weight suffer from this state more frequently. Usually, it causes no serious problem.

Transient hypogammaglobulinemia G is an extension of the physiologic deficiency state to as much as 1 to 4 years when the normal immunoglobulin levels may be attained. It results from gross delay in synthesis of immunoglobulins. Serum IgG level may be under 200 mg/dl. Both sexes are affected, the incidence being higher in preterm infants. The condition is associated with frequent bacterial infections in which situation the infant needs to be administered 0.7 ml/kg (IM) of immune globulin every 2 to 4 weeks for about 6 months.

Panhypogammaglobulinemia (congenital agammaglobulinemia, Bruton disease), usually X-linked, is characterized by low levels of all the three major

Table 29.2: Classification of primary immunodeficiency

- A. *B-cell (humoral) defects*
 - Physiologic hypogammaglobulinemia G
 - Transient hypogammaglobulinemia G
 - Panhypogammaglobulinemia (congenital agammaglobulinemia, Bruton disease)
 - Dysgammaglobulinemia (Common varied immunodeficiency)
 - Selective IgA deficiency
 - Selective secretory IgA deficiency
 - Selective IgM deficiency
 - IgG subgroup deficiency
- B. *T-cell (cellular) defects*
 - Congenital thymic hypoplasia (DiGeorge syndrome).
 - Nezelof syndrome.
 - Cartilage-hair hypoplasia (CHH) syndrome
- C. *Combined B and T cell defects*
 - Wiskott-Aldrich syndrome.
 - Ataxia telangiectasia.
- D. *Nutrophil Defects*
 - Qualitative*
 - Chronic granulomatous disease.
 - Chediak-Higashi syndrome.
 - Job syndrome.
 - Myeloperoxidase deficiency.
 - Lazy leukocyte syndrome.
 - Quantitative*
 - Congenital chronic neutropenia.
 - Isoimmune neonatal neutropenia.
 - Cyclic neutropenia.
 - Schwachman-Diamond syndrome.
 - Congenital splenic defects.
- E. *Complement Defects*
 - Hereditary angioneurotic edema.

immunoglobulins and almost total absence of antibody response. Clinical manifestations include repeated infections with pneumococcus, staphylococcus and *H. influenza* as also viruses, especially ECHO type 30, skin disorders like eczema and recurrent abscesses, malabsorption, *L. giardia* infestation, disaccharide intolerance and increased incidence of malignancy. Diagnosis is made by assaying the serum immunoglobulins—IgM and IgA nearly absent and IgG invariably less than 200 mg/dl. Treatment consists in giving a loading dose of 1.4 ml/kg followed by 0.7 ml/kg of immune serum globulin every 4 weeks, or plasma. Daily prophylaxis with cotrimoxazole is advocated by some authorities. Long-term complications include bronchiectasis, rheumatoid arthritis, malignancy, hemolytic anemia and infection with *Pneumocystis carinii*.

Dysgammaglobulinemia (common varied immunodeficiency) refers to states of absence or deficiency of one or more immunoglobulins. There may well be a compensatory rise in other immunoglobulins.

In *selective IgA deficiency*, recurrent respiratory infections and chronic diarrhea are the common manifestations. There is a remarkable association with autoimmune disease like SLE and rheumatoid arthritis and allergic disorders like asthma and eczema. Administration of diphenyl-hydantoin sodium may also produce this immunologic state. Serum IgA level is under 5 mg/dl. The patient, however, has normal capacity to synthesize IgG and IgM antibodies. Other functions of immunity are normal. The condition may be "transient" or "persistent". It is the commonest primary immune deficiency, forming around 20% of the group. Overall incidence varies between 1 in 400 to 1 in 1,000.

Selective deficiency of secretory IgA may occur in two situations: sudden infant death syndrome (SIDS) and chronic diarrhea.

In *selective IgM deficiency*, prominent clinical features include fulminant hematogenous spread of bacterial infections, atopy and splenomegaly. Common associates are Whipple disease, regional enteritis and lymphoid nodular hyperplasia. A vigorous antibiotic treatment as soon as infection is suspected is indicated.

In IgG subgroup deficiency, total IgG level remains normal. The heterogeneity of its electrophoretic mobility is, however, restricted. As a result antibody formation to some antigen is normal but poor to others. Increased susceptibility to infections is its hallmark. Gammaglobulin therapy proves helpful in *some cases*.

T-Cell Defects

Clinical manifestations suggestive of T cell defects include:

1. Systemic illness following vaccination with any live virus or BCG; unusual life-threatening complication following infection with ordinary benign viruses (e.g. giant cell pneumonia with measles, varicella pneumonia).
2. Chronic oral candidiasis persisting after 6 months of age and resisting adequate chemotherapy.
3. Chronic mucocutaneous candidiasis.
4. Features (fine, thin hair, short-limbed dwarfism with characteristic roentgenographic features) of cartilage-hair hypoplasia (CHH) syndrome.
5. Intrauterine graft-vs-host disease. Most characteristic feature is scaling erythroderma and total alopecia (absence of eyebrows quite striking).
6. Graft-vs-host disease after blood transfusion.
7. Hypocalcemia in newborn (DiGeorge syndrome).
8. Small (< 10 mc diameter) lymphocyte, count persistently under 1500/mm³. **Congenital thymic hypoplasia or aplasia (DiGeorge syndrome)** is characterized by embryonic combined deficiency of thymus and parathyroids (both arise from third and fourth pharyngeal pouches) in association with congenital defects of heart and aortic arch (usually stenosis), hypoplastic mandible, defective ears and short philtrum (Fig. 29.8). Hypocalcemic tetany in the early neonatal period may be the first presenting feature. It responds to high doses of calcium (IV) and vitamin D, provided that low intake of phosphorus is ensured. Eventually, the patient may undergo spontaneous cure or may need thymic transplantation.



Fig. 29.8: *DiGeorge syndrome*. The subject presented with neonatal tetany (that responded to IV calcium, high doses of vitamin D), micrognathia, abnormal ears (both in shape and placement), high-arched and cleft palate, and right-sided aortic arch in chest X-ray. There was demonstrable deficiency in T cell system with normal serum globulin levels. The infant succumbed to septicemia following recurrent infections, including resistant oral and anorectal thrush lingering on over a period of 3 months. Autopsy confirmed presence of only rudimentary thymus

Nezelof syndrome is characterized by the picture seen in DiGeorge syndrome minus parathyroid or cardiac involvement.

Cartilage-hair hypoplasia (CHH) syndrome is characterized by short-limbed dwarfism, scanty hair (with missing central pigmented core) and neutropenia.

Combined B and T Cell Defects (Combined Immunodeficiency)

Clinical symptoms suggestive of combined B and T cell defects include: (i) features of all above, except chronic mucocutaneous candidiasis and nodular lymphoid hyperplasia, (ii) features of Wiskott-Aldrich syndrome, and (iii) features of ataxia telangiectasia.

Wiskott-Aldrich syndrome (WAS), an X-linked recessive disorder, is characterized by eczema, thrombo-cytopenic purpura, discharging ears and susceptibility to infection (Fig. 29.9). Predominant IgM deficiency is remarkable. There is, thus, inability to form antibodies to carbohydrate antigens. Mild dysfunction of T cell occurs. Terminally, patients frequently develop malignant reticuloendotheliosis.



Fig. 29.9: *Wiskott-Aldrich syndrome.* Besides extensive skin lesions that showed waxing and crusting from early infancy, this 1-year-old had recurrent epistaxis and purpura, discharging ears, and frequent intercurrent infections. Platelet count was 40,000/cmm and TLC 8,000/cmm with only 23% lymphocytes. Level of IgM was remarkably low though IgA and IgQ levels were elevated

Ataxia telangiectasia, an autosomal recessive disorder, is characterized by cerebellar ataxia, ocular and cutaneous telangiectasia, chronic sinopulmonary disease and endocrinal abnormalities. IgA and IgE deficiency and variable degree of T cell deficiency constitute its hallmark. Death usually follows development of malignant lymphoma.

Neutrophils Defects

Chronic granulomatous disease (CGD) is characterized by granulomatous lesions in skin lymph nodes, liver, lungs, spleen, and bones (Fig. 29.10). Infection occurs usually by bacteria which are normally of low virulence, and fungi. Cellular and antibody responses are normal. The real defect lies in the bactericidal activity of the neutrophils due to failure their to generate microbial oxygen products. The defect can be detected *in vitro* by the NBT (nitroblue tetrazolium) test. Normally, almost 90% of leukocytes reduce the dye to a purple-black



Fig. 29.10: *Chronic granulomatous disease.* This 10-year-old boy presented with chronic generalized lymphadenopathy (most marked in the cervical and axillary regions where the nodes showed multiple discharging sinuses), hepatosplenomegaly, and remarkable bilateral hilar prominence as also widening of the superior mediastinum (not due to thymus) in the chest X-rays. Investigations revealed no convincing evidence of tuberculosis. Empirically, antituberculous therapy was given without any relief. Later, NBT test showed that only 7% of leukocytes reduced the dye to purple-black. Cellular and antibody responses were found to be normal

compound. In granulomatous disease, hardly 10% or even less are able to do so. The disease is usually X-linked recessive (males affected, females carriers). Long-term prophylactic therapy with cotrimoxazole is of considerable value.

Chédiak-Higashi syndrome (CHS), an autosomal recessive disorder, is characterized by partial albinism and recurrent pyogenic infections (especially of skin). Giant cytoplasmic granules in leukocytes are characteristics. The bactericidal defect seems to be due to change in lysozyme membrane. Response to corticosteroids is often gratifying.

Job syndrome (hyper-IgE syndrome), a condition quite similar to chronic granulomatous disease, is characterized by recurrent cold abscesses (staphylococcal), skin pigmentation, chronic eczema and red hair. It occurs exclusively in males. IgE levels are remarkably high. Many patients have depressed chemotaxis of neutrophils and monocytes. The underlying defect appears to be in cell-mediated immunity.

Myeloperoxidase deficiency is characterized by susceptibility to *Candida* septicemia since the defect causes inability to kill fungi, especially *Candida*.

Lazy leukocyte syndrome, a specific disorder of leukocyte function, is characterized by gingival stomatitis, recurrent URI, including otitis, skin infection and persistent fever. There is leukopenia and absence of polymorphonuclear motility from bone marrow into circulation.

Congenital chronic neutropenia, isoimmune neonatal neutropenia, cyclic neutropenia, Schwachmann-Diamond syndrome, and congenital splenic defects figure among the prominent quantitative deficiency states of neutrophils.

Complement Defects

Deficiencies of individual fractions of complement are very rare. Absence of C₁ may cause *hereditary angioneurotic edema* characterized by swelling of the affected part. With involvement of gut wall, severe abdominal cramps may lead to unnecessary surgery. Laryngeal edema may prove fatal. SLE may occur as a complication. Hypercatabolism of C₃ causes increased frequency of infections and that of C₅ causes recurrent pyogenic infections.

II. SECONDARY IMMUNODEFICIENCY

An overwhelming majority of immunodeficiency states are secondary to other defects (Table 29.3).

Table 29.3: Classification of secondary immunodeficiency

B cell (humoral) defects

Loss of immunologic material, e.g. nephrotic syndrome, protein-losing enteropathy
Infections, e.g. malaria, Epstein-Barr virus infection, trypanosomiasis

T cell (cellular) defects

Nutritional deficiency state, e.g. protein-energy malnutrition, iron, zinc, biotin, vitamin B, or folate deficiency.
Viral infections, e.g. measles, intrauterine infections, Chronic granulomatous disease, e.g. tuberculosis, sarcoidosis, leprosy Renal failure
Reticuloendotheliosis
Thoracic duct fistula
Intestinal lymphangiectasia
Severe tricuspid regurgitation

Combined B- and T-cell defects

Adenosine deaminase (ADA) deficiency
Nucleoside phosphorylase (NP) deficiency
Immunosuppressive therapy
Cytotoxic therapy
Irradiation
Bone marrow aplasia
Severe/fulminant infection
Congenital rubella

Neutrophil defects

Malnutrition	Kartagener syndrome
Myeloid leukemia	Ichthyosis
Down syndrome	
Acrodermatitis enteropathica	
Cryoglobulinemia	SLE
Viral infection	Rheumatoid arthritis
Overwhelming infection	Hodgkin lymphoma

Complement defects

Chronic membranoproliferative nephritis	
SLE	Thalassemia
Neonatal period	Splenectomy
Severe burns	Nephrotic syndrome
Malnutrition	Lepromatous leprosy
Anorexia nervosa	Bacterial endocarditis
Leukemia on drugs	Malaria
Chronic cirrhosis	Glandular fever
	Reye syndrome
Sickle cell disease	Gram-negative septicemia

DIAGNOSTIC APPROACH IN IMMUNODEFICIENCY

Clinical Clues

High index of suspicion is of vital importance in identifying children with immunodeficiency.

The most common reason for suspecting immunodeficiency is very high frequency of severe infections. Remaining characteristics of such infections are (i) prolonged duration with complications, (ii) repeated infections with hardly any symptomfree period, (iii) multisystem involvement, and (iv) invasion with unusual micro-organisms.

Adverse reactions to live vaccines should also arouse suspicion of an immunodeficiency state.

Children with asthma or other allergic diseases have some 7% chances of suffering from an immunodeficient disorder.

Chronic diarrhea may be a manifestation of an immunodeficient state. Such a child suffers from persistent giardiasis and failure to thrive.

In the birth history, it is desirable to find out history of rubella during pregnancy, as also about the baby's gestational age, birth weight and any neonatal illness.

Any evidence of unusual or severe course of such childhood diseases as measles and chickenpox should be sought.

Past history should also include history of surgery on tonsils and adenoids, radiation to thymus and human gammaglobulin therapy.

Family history of a severe infection, early deaths of members, collagenosis or consanguinity may provide a clue to an inherited immunodeficiency defect. It is a good idea to prepare a pedigree tree.

Physical examination of a suspected case is quite important. The child with immunodeficiency invariably shows growth retardation with short stature, irritability, and pallor. Pyodermas, eczema, stomatitis, perianal excoriation and ear discharge are common accompaniments. Despite recurrent upper respiratory infection, tonsils are either rudimentary or absent and cervical lymph nodes are absent.

In Table 29.4 are summarized the clinical clues and the likely immunodeficiency state.

Table 29.5 lists the skin lesions and the related immune defects.

Investigations

Initial screening tests are:

TLC/DLC: A total count of less than 2,000/cmm suggests T-cell deficiency. Howell-Jolly bodies point to impaired splenic function or absolute asplenia. Giant granules in granulocytes suggest Chediak-Higashi disease.

Table 29.4: Clinical clues to various immunodeficiency states

<i>Clues</i>	<i>Likely immunodeficiencies</i>
<ul style="list-style-type: none"> Growth retardation, ill look, pallor, irritability Peculiar faces (micrognathia, hypertelorism, low-set ears, notched pinna) Albinism Red hair Fine hair 	Common to most immunodeficiencies DiGeorge syndrome (congenital thymic hypoplasia)
<ul style="list-style-type: none"> Alopecia Conjunctivitis Uveitis Telangiectasia Oral thrush with ulcers 	Chediak-Higashi disease Job syndrome Cartilage hair hypoplasia with SCID SCID IgA deficiency IgA deficiency Ataxia telangiectasia Chronic mucocutaneous candidiasis
<ul style="list-style-type: none"> Macroglossia Chronic ear discharge 	CMI immunodeficiency Chronic granulomatous disease X-linked lymphoproliferative disease Wiskott-Aldrich syndrome Opsonic function disturbance Immunoglobulin deficiency IgA deficiency
<ul style="list-style-type: none"> Excoriation of nasal mucosa and sinusitis Bronchiectasis/pneumonia Congenital heart disease Dextocardia Hepatosplenomegaly Ataxia Arthritis Poor muscle mass with joint enlargement 	Immunoglobulin deficiency CMI immunodeficiency Immotile cilia syndrome Chronic granulomatous disease Ataxia telangiectasia Complement deficiency IgA deficiency

Table 29.5: Characteristic skin manifestations in immunodeficiency

<i>Skin findings</i>	<i>Associated immune defects</i>
Eczema or petechiae	Wiskott-Aldrich syndrome
Telangiectasia	Ataxia-telangiectasia
Oculocutaneous albinism	Chédiak-Higashi syndrome
Dermatomyositis like rash	X-linked agammaglobulinemia
Chronic dermatitis	Hyper IgE syndrome
Lupus-like rash	Complement deficiency
Cutaneous scars and nonhealing ulcers	Phagocytic defects
Molluscum contagiosum	T-cell defect
Extensive warts	T-cell defect
Candidiasis	T-cell defect

Immunoglobulin levels IgA, IgG and IgM are done initially and, if warranted, IgD and IgE may be done at a later stage. The values need to be compared with the normal values on age-matched controls.

Schick test This test is of significance in only subjects who have had triple vaccine or DT. "No reaction" in these individuals means good immunologic status.

Opsonin function The function of opsonins (the two chief ones are antibodies and complements) is tested by mixing white blood cells and bacteria in the presence of subject's serum. After incubation at 37°C for 20 minutes, a stained preparation is prepared. It is examined for the number of bacteria which have been engulfed by the cells. A count of less than 300 bacteria/100 white cells suggests abnormal opsonic function.

More advanced tests which may be done in selected cases include hemagglutinin titer, delayed hypersensitivity skin tests using streptokinase-streptodornase, CH50 assay, and NBT test.

A good history, clinical examination and the four screening tests mentioned here are capable of identifying about 98% of the immunodeficiency states in pediatric practice.

Treatment

It is outlined in discussion of specific entities in appropriate chapters. Generally speaking, attention to the primary causative condition (in most cases PEM) is of vital importance.

Specific modalities include plasma infusion (complement deficiency), IVGG (X-linked gamma-globulinemia, ITP, HUS, etc.), interferon gamma (chronic *granulomatous* disease), zidovudine (AIDS), etc.

IMMUNOLOGIC BASIS OF AUTOIMMUNE DISEASE

That human body normally produces antibodies against a foreign substance and not against its own constituents (the so-called "self-antigen"), which the body readily recognizes, is well established. A breakdown in the mechanism of recognition of self-antigen and nonself-antigen may lead to development of autoantibodies in a group of disorders referred to as autoimmune disease. Two groups of autoimmune disease are:

I. Associated with common body antigen

Rheumatoid arthritis
Idiopathic thrombocytopenic purpura (ITP)
SLE
Scleroderma
Polyarteritis nodosa
Acquired hemolytic anemia.

II. Associated with inaccessible antigen

Hashimoto disease
Sjögren syndrome
Sympathetic ophthalmitis
Multiple sclerosis
Peripheral neuritis.

One of the following mechanisms may operate in the production of autoimmune disease:

1. Body antigen may not be recognized as self-antigen, leading to production of autoantibodies.
2. An infection or a drug may modify an endogenous molecule so that its antigenic determinants are changed and virtually a new antigen is formed, e.g. rheumatoid arthritis in which there is denaturation of gammaglobulin.
3. Antibodies to a vaccine (say antirabies vaccine) may cross-react with some host components, e.g. antirabies vaccines.
4. Constant exposure of lymphoid tissues to small amounts of antigens may lead to breakdown of "immune tolerance" (complete or partial) and production of forbidden clones, e.g. SLE. Here B cells are responsive but T cells are not.
5. B cell stimulation may result from powerful adjuvant effect of microbes.

IMMUNOLOGIC BASIS OF ALLERGY (ATOPY)

Allergy is an altered state of hypersensitivity resulting from the interaction of antigen with humoral antibody or cellular immune response, occurring in a host sensitized by prior exposure to the antigen.

Type I reaction, also called *immediate reaction*, refers to anaphylaxis, atopy etc. that appears rapidly and disappears rapidly. It is mediated by IgE (only to some extent by IgG) which has unique character of binding homologous mast cells and basophils. Contact with antigen stimulates CAMP system and calcium transport across cell membrane, leading to release of histamine, SRS-A, serotonin, bradykinin and prostaglandins. Eventually such manifestations as bronchospasm and enhanced vascular permeability result.

Type II reaction refers to cytotoxic response, e.g. thrombocytopenia, hemolytic anemias. IgG and IgM as also complement system participates in it.

Type III reaction refers to immune complex or toxic complex, e.g. serum sickness, Arthus phenomenon. IgG, IgM and complement take part in it.

Type IV reaction, also called *delayed reaction*, is manifested by infiltration with mononuclear cells. T cells, lymphokines and macrophages are involved in this response.

Type V reaction is antibodydependent, cell-mediated cytotoxic reaction, brought about by nonimmune killer cells (macrophages or lymphocytes), e.g. thyroiditis.

IMMUNOLOGIC ASPECTS OF MALIGNANCY

Immunodeficiency in association with malignancy may be primary or secondary.

Examples of primary immunodeficiency with malignancy include Wiskott-Aldrich syndrome leading to lymphoid neoplasia and hypogammaglobulinemia causing thymoma. The possible reasons are: (i) failure of an immunologic rejection of normally occurring aberrant cells, (ii) a tendency to develop abnormal lymphoid cells, (iii) a continuous overstimulation by antigens of infecting agents, and (iv) immunodeficiency leading to defects in dealing with an oncogenic virus.

Examples of immunodeficiency occurring secondary to malignant disease include multiple myeloma and chronic lymphatic leukemia.

Treatment with cytotoxic drugs and local irradiation—though desirable—may lead to gross hypertrophy of nonmalignant lymphoid tissue and damage to the limited immunity mechanism in such patients.

IMMUNODEFICIENCY AND SPECIAL RISKS

It is a sound policy not to administer live vaccines to patients with known immunodeficiency. In selected cases, one may consider giving the vaccine in a small dose combined with hyperimmune immunoglobulin.

Even in the case of killed vaccines, care needs to be exercised. Administration of TAB to immunodeficient individuals may result in hemolytic uremic syndrome.

Subject with cell-mediated immunodeficiency should, as far as possible, not receive blood transfu-

sion. In unavoidable circumstances, only irradiated blood should be given.

INTRAVENOUS IMMUNOGLOBULINS (IVIG)

The availability of gammaglobulins for therapeutic use has opened up new avenues in pediatric therapy.

Composition

IVIG is a mixture of IgG (95%), IgM (2%) and IgA (1%). Further the dominant component (IgG) is a mixture of subclasses IgG₁, IgG₂, IgG₃ and IgG₄ in varied proportion. In antiviral antibodies, the dominant subclass is IgG₁ other subclasses are IgG₂ (rubella, rabies, herpes-virus), IgG₃ (rabies, rubella, CMV, varicella zoster, hepatitis B), and IgG₄ (herpes, hepatitis B). Antibacterial antibodies are principally IgG₂ type.

IVIG preparations are available in both liquid and freeze dried forms with or without stabilizers like maltose. On an average, half life is 18 to 32 days. Immediately after a dose of 100 mg/kg, an average increment of 200 mg/dl results.

IVIG preparations available in India include Intraglobin, Pentaglobin, Sandoglobulin, Gammaguard, Isiven VI and Octagam.

Essential Prerequisites/Requirements

The following prerequisites must be satisfied for an IVIG preparation as per the World Health Organization (WHO) guidelines:

- There should be no aggregation or fragmentation.
- Half-life should be same as in case of native IgG.
- Normal subclass distribution.
- Normal complement binding and opsonization (intact Fc receptor).
- There should be no prekalleikrein or kalleikrein activity.
- It should be tolerated by normal or hypogammaglobulinemic subjects.

Indications

- A. Prophylactic Use Against:
1. Measles in a leukemic child
 2. Hepatitis A, especially in European children visiting developing countries
 3. Hepatitis C
 4. Rubella

Intramuscular injections can serve the purpose in all these situations.

B. Replacement Therapy:

1. X-linked agammaglobulinemia
2. Common variable immunodeficiency
3. Hyper-IgM syndrome
4. Immunodeficiency with thymoma
5. SCID
6. IgG subclass deficiencies
7. Some cases of transient hypogammaglobulinemia
8. Some cases of T-cell deficiency.

Children suffering from these disorders can now be led to grow up nearly normally if they receive 200 to 300 mg/kg of IVIG every 3 to 4 weeks so as to maintain IgG at 400 to 800 mg/dl.

C. Relative/Supportive Therapy:

1. *Immune thrombocytopenic purpura (ITP)* The established role of high dose intravenous gamma globulins in selected cases of ITP is discussed elsewhere (Chapter 27).
2. *Autoimmune hemolytic anemia (AIHA)* Therapy with high dose of 5 g/kg rather than the standard dose of 2 g/kg gives good results, especially in subjects who have undergone splenectomy.
3. *Hemolytic uremic syndrome* IVIG in a dose of 2 g/kg/day for 5 days gives good results in HUS not responsive to plasma exchange and fresh frozen plasma replacement.
4. *Acquired factor VIII deficiency* This, the commonest amongst the autoimmune coagulation inhibitors, may be treated with IVIG therapy in subjects who are unsuitable for combination therapy with steroids, cyclophosphamide, vincristine and cyclosporin or who fail to respond to such a therapy.
5. *Rhesus isoimmunization in pregnancy* IVIG, 1 to 2 g/kg for 4 to 5 days, every 2 to 3 weeks to severely Rh-sensitized pregnant women reduces maternal anti-D titers and intrauterine hemolysis and thereby contributes to bypassing intrauterine transfusion to the baby *in utero*. It has also been reported to reduce the bilirubin level and the need for exchange transfusion in neonates with Rh-hemolytic disease.
6. *Secondary immunodeficiencies* In pediatric AIDS, IVIG is definitely of value early in the course

of disease. At this stage, it prevents superadded severe bacterial infections. Later, it loses its protective value.

IVIG is also useful in chronic lymphocytic leukemia (CLL), hypogammaglobulinemia associated with myeloma and recurrent bacterial infections following bone marrow transplantation.

7. *Bone marrow transplantation* IVIG is of value in the cellular and humoral immunodeficient state which exists in a profound magnitude in the first 4 to 6 months after BMT. In early post-BMT period, barrier nursing and granulocyte transfusion contributes to prevent infection more than the IVIG. In late post-BMT period, decreased IgG level with reduced antibody response causes bacterial infections and CMV infection. IVIG helps in this situation by:
 - Decreasing bacterial infections, particularly capsular bacterial sepsis
 - Preventing CMV infection and pneumonia.
8. *Guillain-Barré syndrome* High dose IVIG may cause dramatic relief in postinfectious polyneuropathy (Chapter 23).
9. *Neonatal sepsis/septicemia* There is evidence that prophylactic administration of 120 mg/kg of IVIG in a nursery with high rate of sepsis leads to a significant reduction in neonatal sepsis and mortality. Role of efficacy of such an infusion in the actual treatment of neonatal sepsis remains controversial (Chapter 17).
10. *Pyogenic meningitis* There is evidence that concomitant use of IVIG in patients of pyogenic meningitis on standard antimicrobial therapy contributes to better prognosis and survival (Chapter 23).
11. *Encephalitis* (Chapter 23).
12. *Kawasaki syndrome* In the mucocutaneous lymph node syndrome, high dose intravenous gammaglobulin therapy may reduce the incidence of aneurysms (Chapter 30).
13. *Debatable indications* Allergic conditions such as asthma (severe steroid-dependent), ANCA-positive vasculitis and rhinitis, myasthenia gravis, septic shock, chronic inflammatory bowel disease, kidney transplant, intractable epilepsy, SLE, hemophilia A, etc.

Table 29.6: Definite indications of IVIG

- Primary antibody immunodeficiency
- Immune thrombocytopenic purpura
- Kawasaki disease
- Guillain-Barré syndrome
- Posttransfusion purpura
- Autoimmune uveitis
- Allogenic bone marrow transplantation

Table 29.6 gives the definite indications of IVIG.

Abuse

The use of gammaglobulins is inappropriate in the following situations:

1. Upper respiratory infections in immunologically healthy children
2. Physiologic hypogammaglobulinemia in newborns and preterm infants
3. Malnutrition, both primary and secondary (as in protein-losing enteropathy).

Contraindications

1. Selective IgA deficiency
2. Recent vaccination (except hepatitis B or tetanus)
3. Common variable immunodeficiency with antibodies to IgA (except selected cases with combined IgA-IgG2 or IgA-IgG4 deficiency without antibodies to IgA who may be treated).

Advantages of Intravenous over Intramuscular Immunoglobulin

1. Very high doses can be administered.
2. There is no local pain.
3. There is no proteolytic degradation.
4. Rise in antibody titer is rapid.
5. There is no problem in administering to malnourished children and subjects with active bleeding disorder.

Table 29.7: Adverse effects of IVIG

- Anaphylaxis in patients with IgG deficiency
- Chills, fever, headache, backache and arthralgia
- Dermatologic reactions
- Hypertension with rise in blood urea and creatinine in patients with renal dysfunction
- Transmission of hepatitis B and C and HIV
- Septic meningitis—like illness due to volume overload following a large dose

Hazards

Adverse reactions to intravenous immunoglobulins (Table 29.7) may be related to preparation, to the patient, or to both. Incidence is < 5 % of the recipients. Strict adherence to the criteria laid down by the WHO for intravenous gammaglobulin goes a long way in guarding against the adverse effects.

BONE MARROW TRANSPLANTATION (BMT)

The modality involves administration of marrow-ablative chemoradiotherapy and, thereafter, an infusion of either the recipient's own marrow (autologous BMT) or a donor's marrow (allogenic BMT). For details, see Chapter 28 (Pediatric Oncology).

FURTHER READING

Articles/Chapters

1. Chatterjee T. Primary immunodeficiency. In Gupte S (Ed) *Recent Advances in Pediatrics*-14. New Delhi: Jaypee 2004: 372.
2. Fleischer TA, Ballou M. Primary immune deficiencies: Presentation, diagnosis and management. *Pediatr Clin North Am* 2000;47:1197.
3. Kulkarni ML. Hereditary (primary) immunodeficiencies. In Gupte S (Ed): *Recent Advances in Pediatrics*-12. New Delhi: Jaypee 2002:259.
6. Trehan A, Singh S. Intravenous immunoglobulins. In Gupte S (Ed): *Recent Advances in Pediatrics*-9. New Delhi: Jaypee 1999;258-268.

Book/Monograph

1. Steihm RE. *Immunological Disorders in Infants and Children*, 4th edn. Philadelphia: Saunders 1996.

CHAPTER



30

Pediatric Collagenosis

Suraj Gupte, DM Sharma

INTRODUCTION

The following six major diseases with many similarities are conventionally grouped under this class:

1. Rheumatic fever
2. Rheumatoid arthritis
3. Systemic lupus erythematosus
4. Dermatomyositis
5. Polyarteritis nodosa
6. Scleroderma.

Their common characteristics are several. First, all involve the collagen of the connective tissue. Secondly, our knowledge of their exact etiology is at present far from adequate. Thirdly, fibrinoid degeneration, granulomatous reaction with fibrosis, and vasculitis with proliferation of plasma cells occurs in each of them. Fourthly, there is frequently an overlapping clinical picture and chronicity with relapses. Fifthly, changes in immunologic status are encountered. Sixthly, improvement following steroid therapy, though often symptomatic and transitory, may occur.

Not that the aforesaid are the only disorders of collagen. There are many more such as Ehlers-Danlos syndrome, Marfan syndrome, Stevens-Johnson syndrome, vasculitides, etc. Except for tissue damage by antigen-antibody macronodules, these immune complex diseases do not have much else in common.

RHEUMATIC FEVER

This fairly common disease represents a hypersensitivity reaction to beta-hemolytic streptococci of Lansfield group. It is discussed in details in Chapter 22 (Pediatric Cardiology).

JUVENILE RHEUMATOID ARTHRITIS (JRA)

It is a chronic inflammatory disease, involving one or more joints and having other systemic manifestations.

The disease occurs twice more frequently in girls than in boys. After the first year, it may occur at any age. However, it usually has its onset at 2 to 5 years in both sexes and at or around puberty in girls. Increased tendency for the disease in family members is known.

Etiopathogenesis

The exact etiology of this collagen disorder is not yet precisely known. Infections, particularly with slow virus, have been blamed. Many believe that the disease may well be an autoimmune disorder, i.e. response of antibody-forming cells to modified self-antigen.

Pathologic changes include filling of the affected joint spaces with inflammatory fluid and nonspecific inflammation of the synovial membrane which is edematous and hyperemic and invaded with plasma cells and lymphocytes. Evidence of nonspecific fibrinous serositis may also be found in pleura, pericardium and peritoneum.

Clinical Features

The disease may have an acute or insidious onset with the variable severity.

The most dominant manifestation is the symmetrical involvement of both small and large joints (Fig. 30.1), including fingers and toes (proximal interphalangeal joints), wrists, temporomandibular joints, ankles, knees, hips and cervical spine. Joints are little swollen, tender and warm. They have reduced



Fig. 30.1: Juvenile rheumatoid arthritis. Note symmetrical involvement (inflammation) of wrists and metacarpophalangeal and interphalangeal joints giving spindle appearance to the fingers. Note involvement of ankles as well

mobility and are usually kept in flexion. In due course, contractures may result. A noteworthy development is the spindle-shaped fingers with shiny and smooth overlying skin. This occurs in about 1 to 3 months after the first involvement of the interphalangeal joints with the disease.

Prolonged fever, usually remittent and irregular but in some cases spiking with chills and rigors, with a morbilliform transitory rash (mainly over the trunk), muscle aches, weight loss, iridocyclitis, subcutaneous nodules, hepatosplenomegaly, lymphadenopathy, pericarditis, myocarditis, pneumonia and pleurisy are the other manifestations of the disease.

Still's disease refers to the illness with acute febrile or systemic onset. It is characterized by Still's triad of arthritis/arthritis, lymphadenopathy and splenomegaly.

In the *monoarticular* or *pauciarticular* disease with only slight systemic manifestations, almost 30% cases eventually develop chronic iridocyclitis.

Diagnosis

Laboratory findings during acute phase include high TLC (usually polymorphonuclear response) and alpha and gammaglobulin fractions of serum proteins. Mild

to moderate anemia is usually present. Antinuclear antibodies, rheumatoid factor (which is constituted by certain macroglobulins), C-reactive protein and LE cell may be positive in a proportion of the cases only. Rose-Waler test is positive in a large majority of the cases.

X-ray findings in the early stages include swelling of periarticular soft tissue, effusion, slight increase in the joint spaces, increase in size of ossification centers, accelerated epiphyseal maturation and excessive longitudinal bone growth. Later, destruction of articular cartilages causes narrowing of the joint space. Disuse may lead to osteoporosis and deformities. There may also be radiologic evidence of cervical spondylitis.

Synovial fluid may show an inflammatory reaction.

Synovial biopsy shows chronic inflammation which is, however, not pathognomonic for rheumatoid arthritis.

ECG is indicated in suspected cardiac involvement.

Echocardiography may detect pericarditis in a high proportion of cases.

Differential diagnosis is mainly from rheumatic fever, SLE, leukemia and ulcerative colitis in case of pauciarticular disease and septic arthritis, traumatic synovitis and tuberculosis in case of monoarticular disease.

Treatment

Drug therapy Until recently, aspirin was considered the drug of first choice. It does not lead to as dramatic a response as in rheumatic fever. In fact, therapeutic response may take days and sometimes several weeks.

Today, nonsteroidal anti-inflammatory drugs (NSAIDs), namely ibuprofen, naproxen and tolmetin are the recommended therapy for pediatric JRA. Their effective anti-inflammatory dose is usually 2-3 times the analgesic dose (Table 30.1). Response usually occurs after 3-4 weeks. A 3-4 months therapy is essential before considering change of drug.

Corticosteroids are indicated in the presence of carditis, pericarditis, pleuritis, and iridocyclitis and in situations where the disease seems life-threatening. Their use may also be considered if the patient has failed to respond to other anti-inflammatory agents over a sufficiently reasonable period and if progressive deformities are occurring. Intra-articular steroid therapy deserves trial when one or two joints are involved and they are retarding rehabilitation of the child.

Table 30.1: Recommended NSAIDs in pediatric JRA

Drugs	Doses	Major side-effects
Naproxen	15-20 mg/kg/day in 2 divided doses	Skin rash, gastritis, dizziness
Ibuprofen	30-50 mg/kg/day in 4 divided doses	Gastritis, hypertension, tachycardia, fluid retention, acute renal failure
Tolmetin	15-30 mg/kg/day in 3-4 divided doses	Gastritis, hypertension, headache, tinnitus, fluid retention, acute renal failure

Methotrexate (MTX), 10-15 mg/m² (O) once a week, should be considered the drug of choice in JRA not responding to NSAIDs.

Slowacting antirheumatic drugs (SAARDs) such as gold salts, d-penicillamine and hydroxychloroquin need to be reserved as “add-on” or adjunctive therapy for JRA failing to respond to MTX.

Other drugs used in refractory JRA are azathioprine, cyclophosphamide, cyclosporine, anti-TNF agents, interleukin-1 receptor antagonists, leflunomide, IVIG, etc.

General measures The role of physiotherapy is significant in the management. During the acute illness, the child must rest in bed with appropriate positioning of the involved joints. Exercise (first assisted, then active and finally resisted) once or twice daily is mandatory even during acute phase.

For relief of pain, the child should be encouraged to take hot bath.

Emotional support and reassurance should be provided to the child as well as the parents.

Superimposed infection should be promptly controlled lest it reactivates the disease during convalescence.

Prognosis

With adequate care, a large majority of the patients have complete functional recovery.

SYSTEMIC LUPUS ERYTHEMATOSUS (SLE)

This highly multisystem collagen disorder is predominantly seen in girls, the occurrence in children under 8 years being infrequent.

Pathology

Pathologically, the hallmarks of the disease are fibrinoid degeneration and necrosis which are found extensively. A characteristic feature is the circulation of autoantibodies which produce the typical *lupus erythematosus*

(LE) cell in the bone marrow. This cell is polymorphonuclear leukocyte. It contains matachromatic inclusion body which displaces the nucleus.

Clinical Features

The onset is gradual with prolonged, irregular fever with remissions of variable duration, joint or muscle pains, malaise, weight loss and a characteristic erythematous rash resembling the wings of a butterfly (*butterfly rash*) over the bridge of the nose and cheeks. Rash may also appear on fingers and palms, soles, palate and buccal mucosa. Alopecia may also be found.

The disease does not spare any organ. Renal involvement, neurologic manifestations, polyarthritis, pericarditis, pleural effusion, pulmonary infiltration, thrombocytopenia, hepatosplenomegaly, generalized lymphadenopathy, abdominal pain, vomiting and diarrhea may occur.

Diagnosis

It is confirmed by demonstrating antinuclear antibodies (ANA) which is a more sensitive test than the LE preparation. Anti-Sm antibodies are a marker of CNS lupus, Anti-Ro/SSA and anti-La/SSB of congenital heart blocks seen in neonatal lupus syndrome, anti-double-stranded DNA antibodies of active SLE and antihistone antibodies of drug-induced lupus erythematosus because of such agents as isoniazid, hydralazine or diphenyl-hydantoin (Figs 30.2 and 30.3).

Treatment

Asymptomatic patients need not be given any treatment. In mild cases (without renal involvement), NSAIDs suffice. In the presence of acute inflammatory manifestations, steroids are indicated. This therapy suppresses these manifestations. It may also inhibit progressive renal disease. Chloroquine is of value for skin and joint manifestations. Antibiotics should be

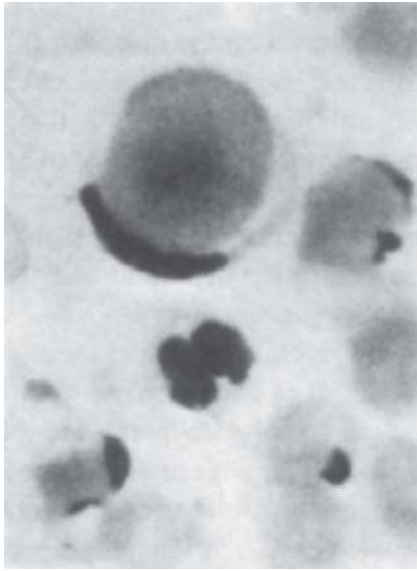

Fig. 30.2: Photomicrograph of peripheral blood highlighting a classical LE cell from a child with SLE

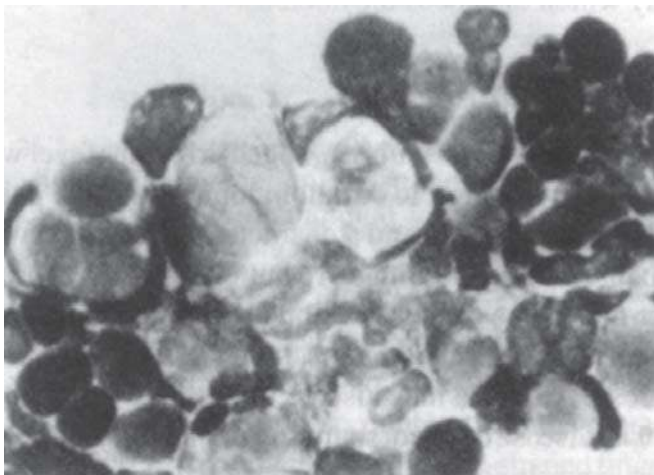

Fig. 30.3: Photomicrograph of peripheral blood showing a cluster of LE cells and hematoxylin bodies along with multiple small inclusions

given as and when infection is suspected. Sunscreen lotions are recommended.

Life-threatening manifestations are an indication for IV pulses of steroids (prednisolone or dexamethasone) followed by oral steroids.

Patients resistant to steroid therapy may respond to immunosuppressive agents such as azathioprine or cyclophosphamide.

An important caution in management is to avoid the use of such drugs as are known to produce lupus-like picture or precipitate SLE. Hydralazine, anticonvulsants, longacting sulfas and methyldopa figure in that list.

Prognosis

With good medical management, survival rate for 5 years is now around 80%. Common causes of mortality are progressive glomerulonephritis, myocarditis and CNS involvement (encephalopathy).

DERMATOMYOSITIS

This rare chronic inflammatory disease of unknown etiology affects mainly the skin, subcutaneous tissue and muscles. The basic lesion is vascular, leading to arteritis and phlebitis.

The onset is insidious. Clinical picture includes fever, muscle tenderness and pain, weight loss, malaise, pseudoparalysis, arthralgia and an erythematous rash. The rash first develops over the bridge of the nose and around eyes and then anywhere over trunk and limbs. An edematous swelling of the malar area and visible capillaries in the nailbed and gum margin are highly suggestive findings. Eventually, the involved muscles become firm, atrophic and contracted. Calcinosis may occur. The face may develop an expressionless appearance, the child hardly being able to fully open the mouth.

In a suspected case, high levels of muscle enzymes, a myopathic EMG and muscle biopsy revealing chronic inflammatory changes may support the diagnosis.

As soon as diagnosis is made, the child must receive steroids. Azathioprine or methotrexate may be tried if response to steroids is poor. Physiotherapy and occupational therapy are important.

With this treatment, prognosis in childhood dermatomyositis is good in a majority of the cases, provided that the therapy has been started fairly early.

POLYARTERITIS NODOSA (*Periarteritis*)

This, another very rare systemic disorder, is characterized by inflammatory lesions in the arterial wall, leading to ischemia from thrombosis.

Clinical picture varies with the location of the affected arterioles. The manifestations are usually those of a rapidly progressive wasting disease. These may include fever, weight loss, generalized body pains, abdominal pain, skin eruptions, subcutaneous nodules, hypertension, hematuria, convulsions, paralysis, CCF, or ischemic gangrene of a limb.

Muscle, testicular or skin biopsy may support the clinical diagnosis.

Steroids may produce dramatic response and prolong life but the results are unpredictable and variable. However, cyclophosphamide, started concurrently, needs to be continued on long-term basis.

The occurrence of renal, cardiac or neurologic involvement usually indicates a poor prognosis.

SCLERODERMA

This rare disorder is characterized by thickening and induration of the skin from deposition of collagen fiber. Systemic manifestations are minimal.

It usually begins in the face, forearm and hands and may or may not spread elsewhere. Because of development of contractures, face becomes masklike, just as in dermatomyositis. Trophic ulcers, calcinosis and Raynaud phenomenon may occur. Involvement of GIT may cause malabsorption. Lesions in the esophagus may lead to obstruction and dysphagia.

A localized form of scleroderma, *morphea*, is characterized by linear band that first shows erythema and edema and later undergoes atrophy, scarring and shrinking.

Differential diagnosis is from scleredema, PKU, porphyria cutanea tarda and progeria (together termed *pseudosclerodermas*).

Morphea responds well to physiotherapy, leaving little or no deformity. Generalized scleroderma (sclerodactylia) has only fair prognosis. Death may occur within a year.

Drug therapy includes penicillamine, cochlincine, pulse steroids, nifedipine, enalapril, etc. A 10-year survival rate is possible in 90% of the pediatric subjects.

MIXED CONNECTIVE TISSUE DISEASE (MCTD)

This disease spectrum is a cocktail of features of SLE, rheumatoid arthritis and dermatomyositis. Anti-ribonucleoprotein (RNP) antibodies are quite high while anti-DNA antibodies anti-extractable-nuclear antigen (anti-ENA) are positive. Response to NSAIDs and steroids is variable.

GOODPASTURE SYNDROME

This condition, only occasionally seen in pediatric practice, is characterized by pulmonary alveolar

hemorrhage (clinically presenting as hemoptysis and secondary anemia) and nephritis. Accompanying manifestations may include dyspnea, cough and pyrexia. Progressive renal failure is common.

Despite therapy with such agents as steroids, alkylating agents and metabolites, the syndrome has a rapidly fatal outcome.

FASCITIS

Diffuse inflammation of the fascial tissues of the extremities and trunk, usually following periods of strenuous physical exertion, may occasionally occur in children. Overlying skin remains unaffected. Besides swelling and tenderness of the affected area, loss of musculoskeletal function and contractures may occur.

Remarkable increase in eosinophils in blood as well as in involved tissues is seen in some subjects. Hence, the other name *eosinophilic fascitis*. Steroid therapy may expedite recovery.

BENIGN RHEUMATOID NODULES

Subcutaneous nodules may occasionally be seen without any evidence of rheumatic disease (clinical or even investigative) in absolutely healthy children. These show a tendency for waxing, waning and recurrence. In due course varying from months to years, recurrences stop. This benign condition needs no therapy.

VASCULITIS SYNDROMES (*Vasculitides*)

In this entity, there is an inflammation of the vasculature. Depending on involvement of large, medium or small sized blood vessels, three groups are recognized (Table 30.2).

KAWASAKI DISEASE (*Mucocutaneous Lymph Node Syndrome, Infantile Polyarteritis*)

First described in 1967 by Prof T Kawasaki of Tokyo, it has emerged as an important cause of vasculitis and heart disease in children. It is primarily a disease of children 5 years of age or younger, occurring worldwide, sporadically or in epidemics.

The role of retroviruses or rickettsia as also immune aberrations as major factors in its causation has not been established.

Table 30.2: Three groups of pediatric vasculitides

<i>Large vessel vasculitis</i>
Takayasu arteritis
Giant cell arteritis
<i>Medium vessel vasculitis</i>
Kawasaki disease
Polyarteritis nodosa
<i>Small vessel vasculitis</i>
Anaphylactoid purpura
Wegener granulomatosis
Behcet disease
Hypersensitivity angitis

Clinical Features

The disease is characterized by prolonged high pyrexia, conjunctivitis, stomatitis, cervical adenopathy and macular erythema with pronounced reddening of the palms and soles and subsequent desquamation of the digits. Diarrhea, vomiting, abdominal pain, hydrops of gallbladder, nerve palsies, seizures, myositis, tympanitis, rhinorrhea, cough, hepatosplenomegaly, iridocyclitis (on slit lamp examination), irritability, and large artery aneurysms are other manifestations. Manifestations of cardiac involvement include coronary vasculitis (ischemia, infarction or rupture of aneurysm), myocarditis, endocarditis, pericarditis, CCF, and arrhythmias. Arthralgia/arthritis, pyuria, proteinuria, mild hepatitis and aseptic meningitis may occur.

Diagnosis

Laboratory findings include mild anemia, leukocytosis, raised ESR, raised C-reactive proteins, normal ASO titer, thrombocytosis, high levels of circulating immune complexes and hypergammaglobulinemia. Tests for rheumatoid factor and antinuclear antibodies are negative. Serum complement levels are normal or slightly elevated.

Cardiac studies must include 2-dimensional echocardiography at time of first presentation and then after 2 weeks for detecting coronary dilatation or aneurysm.

Diagnosis is more or less clinical and should rest on the demonstration of certain criteria (Table 30.3).

Differential diagnosis is from infectious diseases such as infectious mononucleosis, poststreptococcal disease, Stevens-Johnson syndrome, toxic shock syndrome, leptospirosis, JRA, measles, and other vasculitic syndromes.

Table 30.3: Diagnostic criteria for Kawasaki disease

Essential

1. Fever lasting for a minimal of 5 days
2. Illness not explained by any other known disease process

Nonessential (4 of the 5 features suffice)

1. Bilateral nonpurulent conjunctival injection
2. Changes of the mucosa of the oropharynx, including infected pharynx, infected and/or dry fissured lips, strawberry tongue
3. Changes of the peripheral extremities, e.g. edema and/or erythema of hands or feet, desquamation, usually beginning perungually
4. Rash (primarily truncal)—polymorphous but nonvesicular
5. Cervical lymphadenopathy (at least one node > 1.5 cm)

Treatment

Currently the treatment of choice is high dose intravenous immunoglobulin, 2 g/kg as a single dose over 10 to 12 hours or 400 mg/kg/day for 4 days. The response is dramatic. Moreover, it also prevents coronary vascular involvement.

During the febrile phase, the subject should also be given salicylates, 100 mg/kg/day in divided doses. Later salicylate therapy should be continued in low, single-dose, 5 mg/kg/day for 6 to 8 weeks after the active disease has subsided. If coronary lesions are already present, this therapy with or without dipyridamole needs to be carried on until the coronary involvement has regressed.

Heparin or warfarin therapy may be added in case of large aneurysms.

Streptokinase therapy is indicated in case of active phase of coronary artery thrombosis.

Prostaglandin E infusion is indicated in peripheral artery ischemia.

Symptomatic children with gross stenotic lesions may be subjected to aortocoronary bypass surgery.

Prognosis

The disease is generally benign and self-limited, regressing in 1 to several weeks. In some cases, however, there may occur cardiovascular involvement in the form of myocarditis, pericarditis, coronary aneurysms, coronary thrombosis and myocardial infarction, causing mortality in 0.5 to 2.8% cases.

POLYARTERITIS NODOSA

It stands discussed earlier in this very chapter.

ANAPHYLACTOID PURPURA (*Henoch-Schoenlein Purpura*)

See Chapter 27 (Pediatric Hematology).

BEHCET DISEASE

This very rare vasculitis is characterized by aphthous stomatitis, skin lesions, genital ulceration, ocular problems, thrombophlebitis, arthritis, and cardiovascular and neurologic disease, resulting in considerable disability. Response to steroids and/or chlorambucil is variable.

TAKAYASU ARTERITIS

See Chapter 22 (Pediatric Cardiology).

4 WEGENER'S GRANULOMATOSIS

This very rare syndrome is characterized by necrotizing granulomatous lesions of the respiratory tract and lungs along with a systemic necrotizing vasculitis that is most remarkable in lungs and kidneys.

An important diagnostic investigation is anti-neutrophil cytoplasmic antibodies (ANCA), especially ANCA.

Differential diagnosis is from other vasculitides, lymphoma, tuberculosis, allergic alveolitis,

Goodpasture syndrome (described earlier in this Chapter) and fungal infections.

Response to steroids and cyclophosphamide is gratifying.

MARFAN SYNDROME

See Chapter 41 (Pediatric Orthopedics).

EHLER-DANLOS SYNDROME

See Chapter 31 (Pediatric Dermatology).

FURTHER READING

Articles/Chapters

1. Aggarwal A. Juvenile rheumatoid arthritis. In Gupte S (Ed): *Recent Advances in Pediatrics-9*. New Delhi: Jaypee 1999:236.
2. Singh S. Kawasaki disease. In Gupte S (Ed): *Recent Advances in Pediatrics-9*. New Delhi: Jaypee 1999:251.
3. Singh S, Walia A. Juvenile rheumatoid arthritis. In Gupte S (Ed): *Recent Advances in Pediatrics-14*. New Delhi: Jaypee 2004:202-212.

Books/Monographs

1. Cassidy JT, Petty RE. *Textbook of Pediatric Rheumatology*. New York: Churchill Livingstone 1990.
2. Morrissy RT. *Lovell and Winder's Pediatric Orthopedics*. Philadelphia: JB Lippincott 1990.

CHAPTER



31

Pediatric Dermatology

Suraj Gupte, NE Parsons

INTRODUCTION

Approximately 30% of pediatric OPD attendance is accounted by dermatologic disorders as such or as associates of other illnesses. Skin may also be an index of many systemic and genetic disorders. A vast majority of skin problems may be categorized as allergic (atopic dermatitis), infective (bacterial, viral, fungal, parasitic), vascular (hemangiomas, urticaria), pigmentary (vitiligo), scaly, and hormonal (acne vulgaris).

A skin lesion may be primary or secondary. Examples of primary lesion include macule, papule, vesicle and pustule (Table 31.1).

Table 31.1: Precise definitions of morphological lesions in dermatology

Lesions	Definitions
Macule	Well defined but flat lesions with a change in color
Patch	A macule larger than 1 cm in size
Papule	Raised and palpable solid lesion
Nodule	A large papule, usually over ½ to 1 cm in size
Plaque	A raised flat-topped lesion on skin or mucous membrane, usually over 1 cm in size
Vesicles	Raised fluid-filled lesion
Pustule	Pus-containing well-circumscribed lesion
Wheal	Raised, edematous and round lesion of various shapes and sizes; it is white in center and pale red at periphery and is accompanied by itching; seen in urticaria, insect bite, anaphylaxis and angioneurotic edema.

A secondary skin lesion such as crust, scale, ulcer, fissure, erosion, atrophy and lichenification (additional lesions on top of a papule) develops from a primary lesion.

ATOPIC DERMATITIS

Atopic dermatitis, a chronic skin disease characterized by erythema, exudation, lichenification and intense pruritis, usually begins in the first few months of life. In view of its known association with hay fever (allergic rhinitis), asthma and immunodeficiency, it has been suggested that it may well be a late phase IgE-mediated reaction as a result of a constitutional anomaly in the immune system.

Clinical Features

Atopic dermatitis has varied presentation. When it manifests before 3 months of age, the characteristic lesions are erythematous squamous patches that first appear over the scalp, behind the ears, around the nose, buttocks or genitalia. This, the so-called *seborrheic dermatitis*, as rule, resolves in 4 to 6 weeks. In a small proportion, it may progress to infantile eczema.

In *infantile eczema*, rosy erythema of the cheeks is outstanding. In addition, there is fissuring of the skinfolds behind the ears, soddening of the neck folds and dryness and scaling of the extensor surfaces of arms, wrists and legs. Itching is remarkable, the scratching leading to excoriation and secondary infection (both bacterial and with *Candida*). Note that periorbital, perioral, nasal areas, and buttocks are usually spared in infantile eczema. Following a course of remissions and exacerbations, spontaneous remission occurs in a majority of the cases by 1 to 2 years of age.

In *late-onset atopic eczema* or in infantile eczema that continues after 1 to 2 years of age, anterior of neck, flexures of elbows, and knees, and front of ankles show

erythema, scaling and lichenification. This is termed *flexural eczema*.

Atopic dermatitis may also manifest as *numular eczema* (coin-shaped vesicular lesions with severe pruritus), or *pityriasis alba* with hypopigmented patches over face. For diagnosis of atopic dermatitis, 3 major and 3 minor criteria (Table 31.2) must be satisfied.

Table 31.2: Diagnostic criteria for atopic dermatosis

Major

1. Pruritus
2. Distribution over face and convexities in infants under 2 years and over flexures in older children.
3. Tendency to chronicity
4. Personal or family history of atopy

Minor

1. Immediate skin test reaction
2. Delayed blanching to cholinergics
3. Anterior subcapsular cataract
4. Xerosis
5. Ichthyosis vulgaris with an accentuation over palmar creases
6. Facial pallor/suborbital shadowing
7. Infraorbital folds
8. Keratoconus
9. Recurrent skin infections
10. Tendency to nonspecific dermatosis of hands
11. Raised serum IgE

Treatment

It comprises topical low concentration steroid and antibiotic cream, and antihistaminic drugs. A short course (7 to 10 days) of systemic antibiotics is warranted in active disease. Supportive measures include:

1. gentle bathing with a small amount of liquid antiseptic soap,
2. cutting the nails short to prevent scratching trauma,
3. avoidance of nonspecific allergens like dust, nylon, feathers and animal danders, and
4. avoidance of suspected food allergen.

Infants and children with atopic dermatitis are likely to have higher incidence of bronchial asthma. Even apparently asymptomatic children stand good chances of manifesting symptoms of asthma under stress and strain.

INSECT BITE HYPERSENSITIVITY

During summer and rainy season, quite a proportion of children with insect bite, including mosquito and

bedbugs, have a tendency to develop intensely pruritic lesions (pustules, papules) over exposed areas.

Treatment consists in local application of a steroid cream/ointment.

DRUG ERUPTION

Logically speaking, all drugs are capable of causing an eruption, which is usually exanthematous. Nevertheless, the drug notorious in this behalf are sulfonamides, penicillins, anticonvulsants and antituberculous drugs.

Drug eruption is usually a symmetrical itchy macule or papule which quickly spreads to the whole of the skin, including palms and soles, and at times, the mucosal surface too (Fig. 31.1). The initial discrete lesions have a tendency to coalesce to form large patches. Left unattended, the lesion may further spread, ending up as exfoliative dermatitis. Fever and itching may accompany the rash.

Immediate withdrawal of the offending drug leads to regression (or at least no further progression) of the drug eruption.

In addition to withdrawal of the causative drug (all drugs being taken by the child in case there is doubt as to which one is responsible for eruption), it is beneficial to administer systemic steroids for a week or so. Antihistaminics provide only symptomatic relief from itching.



Fig. 31.1: Fixed drug eruption. It classically occurs at the same site if the subject is exposed to the same medication. Hence the name. It is believed to be mediated through type IV hypersensitivity

SCABIES (*Seven-year Itch*)

It is caused by an insect mite, *Sarcoptes scabiei*, and is spread by skin-to-skin contact. No age is immune.

Clinical Features

The characteristic skin lesions are papules and vesicles that involve the skin, usually below the neck. The usual sites are between fingers and toes, ulnar side and front of wrist, elbow, anterior axillary fold, buttocks, umbilicus, and male genitalia. In short, **warm and moist locations of the body are generally affected**. Unlike adults, infants and children may suffer from lesions over face and scalp. Lesions over palms and soles may also occur.

Intense itching and *superadded infection* may cause formation of pustules which, if not treated, lead to more widespread lesions with somewhat changed appearance and even development of crusts.

Acute nephritis may occur as a complication of scabies. Also see Chapter 26 (Pediatric Nephrology).

Diagnosis

Generally, a clinical diagnosis is considered sufficient for prescribing specific therapy. Burrows are considered pathognomonic for scabies.

Confirmation of the diagnosis is by demonstration of the mite microscopically in the scrapplings obtained from burrows, eczematous lesions or fresh papules. The method consists in pouring a drop of a mineral oil on a lesion. With a dull-edged tool, this is vigorously scrapped. Then, the oil and the scrapplings are transferred to a glass slide. Under the microscope, the mite is easily identified by its movements.

Treatment

The time-honored treatment is application of 25% benzyl benzoate, diluted in calamine or water in case of small children, all over the body from neck to toes, after preliminary bath.

Crotamitone, gamma benzene hexachloride, mesulphen, sulfur and DDT are also effective.

Permethrin 5% cream is now considered to be the best scabicide for infants over 2 months and children. Since it is poorly absorbed and rapidly metabolized by tissue esterases, its toxicity is practically negligible.

In case of infected scabies, it is desirable to treat the infection with a suitable chemotherapeutic agent prior to treatment with a scabicide agent.

After the treatment, all clothing, bed linens and towels should be laundered thoroughly (boiled, sunned and ironed).

All contacts should also receive treatment simultaneously, even if they have no overt lesions.

*Ivermectin**, 200 mc g/kg (O), given in 2 doses, one week apart has yielded gratifying results.

Persistent pruritus, even after the skin lesions have disappeared following specific therapy, is usually the result of hypersensitivity to the mite antigen. It should not be interpreted as a failure of treatment. Topical steroid assist in alleviating it.

Nodular lesions of scabies may take several months to disappear.

PEDICULOSIS

Louse infestation of the hairy regions is a common problem in the low socioeconomic group whose personal hygiene is poor.

Three forms of the disease, depending on the body region involved, are known:

1. Pediculosis capitis (head involvement)
2. Pediculosis corporis (body involvement)
3. Pediculosis pubic (pubic involvement).

Pediculosis capitis is the one most frequently encountered. It is relatively commoner in the females. The commonest complaint is intense itching. Scratching causes localized areas of excoriation which very often get infected, causing regional lymphadenitis.

The parasite is seen as an elongated *nit* (egg) near the root of the hair or as an adult louse—many a times almost overcrowding the hairy area.

Treatment consists in local application of DDT (5%), benzyl benzoate (12.5%) or permethrin (5%).

The hair should be left as such for a few days after application of the medicine. Then it should be washed. Resistant or heavy infestation may need one or two more applications at weekly intervals.

If superadded infection exists, it must be treated before applying DDT, benzyl benzoate, or permethrin.

* Ivermectin is effective in intestinal parasitic infestations

RINGWORM INFECTIONS

(*Dermatophytosis, Dermatophycosis*)

Dermatophytes, the highly specialized fungi, may cause a variety of lesions of skin and its appendages. In Kashmir, incidence of ringworm infections is fairly high.

Tinea capitis consists of seborrhea-like scaly and circumscribed patches. In advanced cases, alopecia occurs (Fig. 31.2). It responds well to oral griseofulvin, 20 mg/kg/day for 5 to 7 days. Topical application of an antifungal cream (Whitfield, for instance)—in addition to the oral therapy—is of value.

Tinea corporis consists of scaly patches—round and erythematous. A noteworthy feature is that the patch spreads towards the periphery which is quite inflamed while it tends to clear at the centre. Local use of Whitfield ointment suffices. In case of poor response, it should be combined with griseofulvin.

Tinea cruris consists of similar lesions as in *tinea corporis*. It is, however, limited to the genitocrural area, usually sparing the scrotum. Whitfield ointment brings about cure.

Tinea pedis is the infection of the intertriginous area (between the toes) in the form of fissures and macerations or the plantar surface of the feet in the form of vesicular patches. Whitfield ointment gives gratifying results.



Fig. 31.2: Alopecia as a result of infection with the fungus, *Tinea capitis*. The condition needs to be differentiated from traumatic alopecia, trichotillomania and alopecia areata

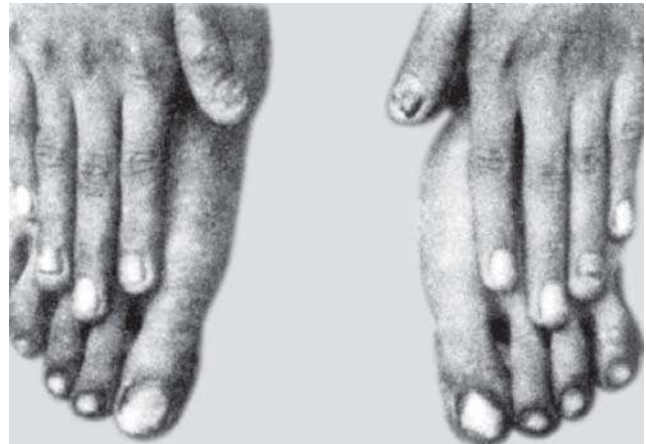

Fig. 31.3: Ringworm infection of nails

Ringworm infection of nails (Fig. 31.3), also called onychomycosis is a rather more chronic and resistant condition. Griseofulvin treatment is good enough but it has got to be administered for a prolonged period. Generally, finger-nails require 3 to 4 months and toe-nails 6 to 12 months course. Some patients may have to be supplemented with topical antifungal applications.

Tinea versicolor (*Pityriasis*) is a common fungal infection of the skin in tropical regions. The etiologic fungus is the *Microsporum furfur*. The characteristic lesions are small yellowish-brown macules. These slowly blend to form large disfiguring areas. Concomitant hypopigmentation is usual. The common sites are chest, neck and back of trunk.

Treatment is local application of 10% sodium thiosulfate twice daily. Whitfield ointment, 0.25 to 0.5% strength, and selenium sulfide are also effective. Recurrences are frequent, however.

MONILIASIS (*Candidiasis*)

It is caused by the fungus, *Candida albicans* and is common in early infancy. The lesion may be scaly, papulovesicular or erythematous with sharp border. The common sites of involvement are diaper area, especially external genitalia (Fig. 31.4) and surrounding skin, inguinal region, axilla and other moist areas that are subject to rubbing. Besides skin, candidiasis may involve mucous membrane of the mouth (*thrush*) and even viscera.

The causes include infection of the infant from mother's vagina. Broad-spectrum antibiotics, diabetes, obesity, hypoparathyroidism, malnutrition, prematurity and adrenal insufficiency predispose to moniliasis.



Fig. 31.4: Vulval moniliasis. It needs to be differentiated from napkin rash and skin lesions of acrodermatitis enteropathica

Treatment consists in local application of 0.5% gentian violet, nystatin cream, iodochlorhydroxyquin or 3% amphotericin B.

DIAPER RASH (*Nappie or Napkin Flash, Intertrigo*)

This condition usually occurs sometime during the diaper-wearing period of infancy. It is attributed to excessive water-logging of the local skin from stools and urine and increased perspiration with retention of sweat. It is said to be a sort of reaction to ammonia formed in the voided urine.

Clinical Features

The rash may be mild erythematous reaction covering the perineal region, buttocks and genitalia. In others, it may be severe with papulovesicular lesions and ulcers. Superadded infection with a fungus or bacteria may further complicate the picture.

Treatment

Once the diaper rash has occurred, treatment consists in exposing the affected area to warm, dry air during day time. At night, zinc oxide ointment may be applied locally. Superadded infections should also receive attention. If these measures prove ineffective, topical hydrocortisone (0.5 to 1%) application is indicated provided that candidal infection has been excluded.

Diaper care is of primary importance as regards prevention of this common problem.

PRICKLY HEAT (*Sudamina*)

Also called *heat rash* and *miliaria rubra*, this condition consists of pinhead sized erythematous papules over face, neck, shoulders and other areas where sweat glands are in plenty. The basic lesion is obstruction of openings of sweat glands from excessive sweating. The commonest cause is hot weather or overclothing. It may occur in febrile illnesses.

Treatment is directed at reducing too much of clothing and providing cool and dry environment. A good quality dusting powder or calamine lotion is of value.

SEBORRHEA

Seborrheic dermatitis (Fig. 31.5), a disease of unknown etiology, is very common in infancy and childhood. Usually, it fails to receive attention in the wake of more dramatic picture of the major illness.

Clinical Features

Dandruff or seborrhea of the scalp is characterized by scaling and poorly-circumscribed erythematous rash covered with oily crusts (Figs 31.6 and 31.7). *Cradle cap* is the name given to it in case of infants.



Fig. 31.5: Seborrheic dermatitis. Note the diffuse scaling and crusting of the scalp (cradle cap), and erythematous rash over the face



Fig. 31.6: Seborrheic dermatitis of scalp (cradle cap) in an infant. Note the scaling and erythematous rash covered with oily crusts

4



Fig. 31.7: Seborrheic dermatitis, showing gross involvement of both scalp and skin

This may extend downward to involve all the oily areas such as forehead, neck, ears, eyebrows and nose.

Treatment

Seborrheic dermatitis of scalp responds well to a local application containing salicylic acid, sulfur and coal tar. Among other antiseborrheic agents, selenium sulfide suspension is of outstanding value.

For seborrhea of face and rest of the body, 1% hydrocortisone (or other steroid cream) or iodochlorhydroxyquin is effective. Hydrocortisone application is indicated in resistant cradle cap too.

Along with these measures, child's nutrition should be taken care of and vitamin supplements given if needed. Also, fat should be reduced in diet and any influences causing tension avoided.

URTICARIA (*Nettle Rash*)

A common but self-limiting disorder, it is allergic in origin.

The characteristic lesions are very irritating "wheals" that may blend to involve large areas of the body (Fig. 31.8). Rash is frequently noticed, after a warm bath, around pressure points of the body.

A localized form of urticaria is called *angioneurotic edema*. It may involve lip or some other part of face, penis or larynx. The swelling is usually over in a matter of hours.

Treatment consists of local application of calamine lotion and antihistaminic agents to relieve itching. If unsuccessful, epinephrine or corticosteroids may be employed.

PYODERMAS

The skin of infants and young children is particularly susceptible to infections with *Staphylococcus* or *Streptococcus*. Skin response to such a bacterial pathogen is



Fig. 31.8: Urticaria (nettle rash)

dramatic in the form of blisters. Why? Perhaps because of its immaturity or some biochemical and other factors.

Classification

I. Primary

- Dermatitis exfoliative of newborn
- Impetigo (Fig. 31.9)
- Folliculitis (furuncles)
- Sweat gland infections
- Paronychia infections.

II. Secondary

Superadded on conditions like

- Scabies
- Seborrhea
- Diaper rash.

Treatment

Local applications of an ointment containing neomycin and bacitracin together with oral or systemic penicillin, erythromycin, cloxacillin or cephalexin is the treatment of choice. In mild infections, gentian violet, 0.5 to 1.0%, serves the purpose.

Untreated pyoderma may be complicated by several conditions (Table 31.3).



Fig. 31.9: *Impetigo*. Note that the vesicular and pustular lesions are covered by thick crust. Pain and systemic manifestations are usually conspicuous by their absence. Itching, lymphangitis and regional lymphadenitis are common. Penicillin is the drug of choice for this superficial skin infection due to group A beta-hemolytic streptococci

Table 31.3: Complications of bacterial skin infection (pyodermas)

Uninhibited spread: Cellulitis, osteomyelitis, septic arthritis, pneumonia, cavernous sinus thrombosis

Acute streptococcal: Scarlet fever, lymphangitis, lymphadenitis

Post-streptococcal: Acute glomerulonephritis

Recurrent pyodermas warrant use of a soap substitute containing hexachlorophene followed by rinsing of the head by all family members with 70% alcohol regularly. This is in addition to the treatment outlined for acute infection. Attention to hygienic aspects is also essential to prevent recurrences.

ERYSIPELAS

This streptococcal skin infection is characterized by cellulitis and lymphangitis only of the skin (subcutaneous tissue is spared).

Manifestations include large patch of erythema with induration and raised firm borders, pyrexia and irritability. As erythema stops progressing marginally, constitutional symptoms disappear.

Complications include deep cellulitis, subcutaneous abscess formation and septicemia with metastatic abscesses/foci. Drug of choice is penicillin.

SCALDED SKIN SYNDROME (SSS)

Also termed *Ritter disease*, *Lyell syndrome* or *toxic epidermal necrolysis*, this condition may be the result of *Staphylococcus aureus* infection, drugs (aspirin, allopurinol, phenobarbital, methotrexate, penicillins, phenylbutazone, diphenylhydantoin, sulfas, thiazides) or immunologic disturbance (graft-vs-host disease).

Staphylococcal scalded skin syndrome (SSSS) is the one most frequently seen in clinical practice. It is a generalized manifestation of a local *staphylococcus aureus* infection, usually phage 2 type, the initial infective focus being in the umbilicus, circumcision site, conjunctiva or oropharynx. The infecting strains of the staphylococci elaborate an exotoxin, *exfoliatin*, which is responsible for the clinical manifestations.

The clinical picture is characterized by appearance of a generalized rash which is followed by development of superficial bullae filled with clear nonsterile fluid. The bullae have a tendency to rupture easily. Desquamation of extensive areas of epidermis occurs, leaving raw, weeping, red "scalded" looking

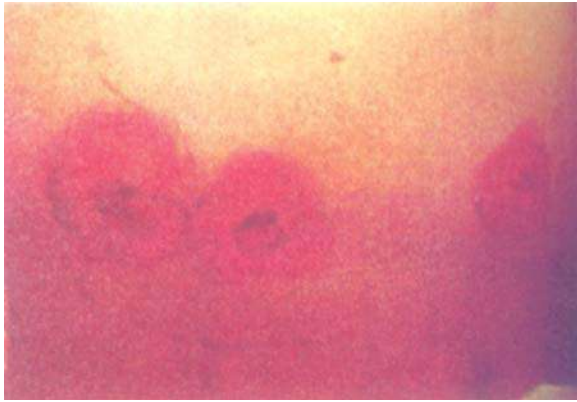

Fig. 31.10: *Staphylococcal scalded skin syndrome (SSSS).* Nikolsky sign (separation of areas of epidermis in response to gentle stroking) was positive

history of failure to go into labor spontaneously and were refractory to the agents usually employed to induce parturition.

Ichthyosis congenita is characterized by a thick horny covering, with intervening prominent fissures, of a very remarkable severity.

Ichthyosis vulgaris is characterized by slight scaling and dryness, mostly over arms and legs, which is worse during winter months. Its severe form is characterized by widespread scaling, geometrical figures separated by shallow fissures (Figs 31.11 and 31.12). Follicular hyperkeratosis or palmoplantar lesions occur frequently. Inheritance is autosomal dominant. It should be differentiated from secondary ichthyosis (Fig. 31.13) which disappears following treatment of the causative factor.

Congenital ichthyosiform erythroderma is characterized by widespread hyperkeratosis and persistent erythema. The skin lesions improve but intolerance to heat during summer months is “troublesome”. In a newborn, it manifests as blisters, ectropion and claw-like fingers.

Lamellar exfoliation of newborn is characterized by a widespread keratinous covering which starts peeling off within 24 hours leaving normal underlying skin. The process of peeling is over in a few months.

Colloidion baby, usually a form of lamellar ichthyosis, is characterized by a thick membrane at birth, flattened nose and ears, ectropion and lips fixed in an “O-like” configuration. The membrane sheds, the process taking a week to several weeks (Fig. 31.14). High susceptibility to skin infections has a bearing on the eventual outcome.

Harlequin fetus, a very rare autosomal recessive disorder, is characterized by thick, horny membrane over the whole body, grotesque appearance with flattened nose and ears, gross ectropion, chemosis, everted and gaping lips, absent hair and nails, restricted mobility of joints, poor suckling and respiratory difficulty. Prognosis is bad, a vast majority of patients dying in the first few weeks.

When present in association with cerebellar ataxia, progressive nerve deafness, polyneuritis and retinitis pigmentosa, ichthyosis is called *Refssum syndrome*. It usually manifests after 4 years of age. Association of ichthyosis with keratitis and neurosensory deafness is termed *KID syndrome*.

4

surface, initially in the flexures and later over most of the body. At this stage, light rubbing or stroking of the skin results in wrinkling and separation of the outer layers of the epidermis, the so-called *Nikolsky sign* (Fig. 31.10). Healing of the lesions occurs rapidly and is complete in 1 to 2 weeks without leaving any scarring.

Accompanying manifestations include superficial stomatitis, conjunctivitis or pharyngitis.

Complications include dehydration, electrolyte imbalance, cellulitis, pneumonia, septicemia and faulty temperature regulation.

Therapeutic measures must include a semi-synthetic penicillinase-resistant penicillin, say cloxacillin.

ICHTHYOSIS*

This term refers to hereditary hyperkeratinization (excessive cornification) of skin which becomes dry, thick and scaly.

X-linked ichthyosis, a relatively common condition, is seen in males only. It manifests right at birth, or by the age of 4 months. There is frequent involvement of scalp and neck besides limb and trunk. The palms and soles are spared. There is no hair and nail involvement. Corneal opacities may be seen in patients and carrier mothers and sisters. There is a seasonal variation in intensity. The cause is deficiency of steroid sulfatase (a microsomal enzyme) activity in skin fibroblasts. It is interesting that most mothers of such patients have

* Drugs like triparanol and diseases like malnutrition, malabsorption state, hypothyroidism or Hodgkin lymphoma may cause ichthyosis-like picture

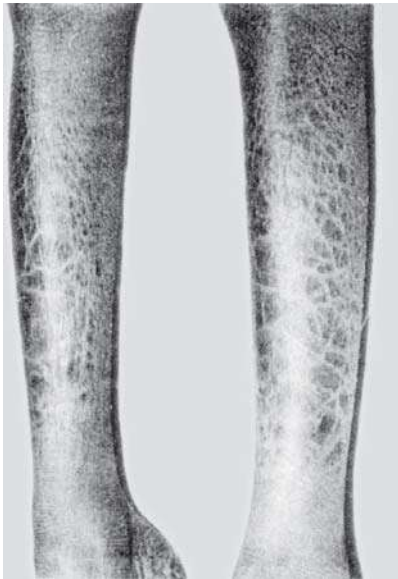

Fig. 31.11: Ichthyosis vulgaris, showing extensive scaling over extensor aspects of legs



Fig. 31.13: Secondary ichthyosis. Note the classical lesions. Following antituberculous therapy (note the massive cervical adenitis) and improvement in nutritional status, skin lesions disappeared

4

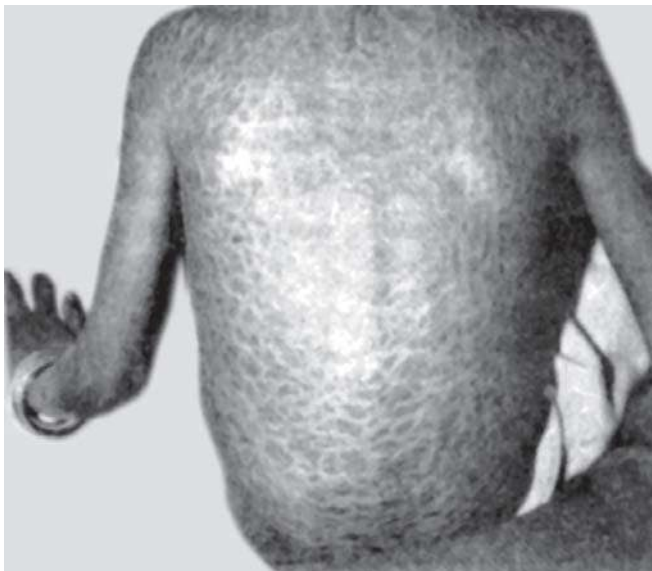

Fig. 31.12: Ichthyosis vulgaris, showing widespread scaling over the back



Fig. 31.14: Lamellar ichthyosis. Note that the collodion membrane is in the process of desquamation

There is no specific treatment. The recommendations include lubrication of skin with emollients and keratolytic agents, say mineral oil and/or topical vitamin A and large doses of vitamin A (oral), and salicylic acid or retinoic acid in winter.

CAFE-AU-LAIT SPOTS

Cafe-au-lait spots are brownish, oval macules, found anywhere on the body in 22% of dark and 10% of white children. The presence of 6 or more such spots of more

than 1.5 cm diameter should arouse suspicion of *neurofibromatosis* or Albright syndrome (pseudo-hypoparathyroidism).

ALBINISM

Albinism is an inborn error of metabolism, characterized by poor or nil pigmentation of the skin and hair (Fig. 31.15). In total albinism, iris is pink or bluish and pupils are red. Photophobia, nystagmus and refractive errors are common. Incidence of mental retardation among *albinos* is high.

Genetically speaking, albinism is an *autosomal recessive* disorder. Consanguinity can be traced in a large proportion of the cases.

The basic defect is the deficiency of the enzyme, *tyrosinase*. The particular enzyme is responsible for conversion of DOPA to melanin.

No specific treatment is available for this condition. However, refractive errors should be corrected. Further, eyes and skin should be protected from the bright sunlight.

VITILIGO (*Leukoderma*)

This genetic disorder is characterized by milk white patchy lesions over skin (Fig. 31.16). The cause is an autoimmune damage to melanocytes in the dermis. Treatment is in the form of local steroid application and systemic psoralens. Prognosis is guarded.



Fig. 31.15: Albinism (left) against a control (right). The patient suffered from marked photophobia. He had juvenile diabetes too



Fig. 31.16: *Vitiligo*. Note the completely depigmented macules of varying shapes and sizes

LEPROSY

Hypopigmented (light rather than white) and anesthetic macules may well be a manifestation of leprosy. For details, refer to Chapter 19.

HEMANGIOMA

It is an example of hamartoma in which vascular tissue is present in excess in the skin. Three types are usually recognized:

Portwine stain or *mark* (*nevus flammeus*) is a well-defined flat, superficial non-blanching angiomas, red to dark purple in color, that may involve up to half of the body surface of the newborn, the back of the neck and face showing special predilection though any area of the body may be involved (Figs 31.17 and 31.18). It may accompany Sturge-Weber syndrome, Klippel-Trenaunay-Weber syndrome, Rubinstein-Taybi syndrome, Cobb syndrome, Beckwith syndrome and trisomy 13.

Capillary hemangioma (*strawberry mark*) is a sharply-demarcated, somewhat raised, semiblanching, bright red spot, that may be present at birth but usually appears during the earlier weeks of life. The size varies from many mm to 2 or 3 cm. An overwhelming majority disappear spontaneously by 10 years of age. This type is the most common.



Fig. 31.17: Large hemangioma. Note that no other body part was involved



Fig. 31.19: Massive cavernous hemangioma

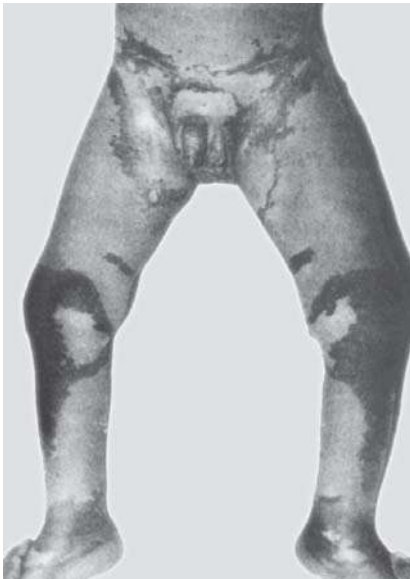

Fig. 31.18: Extensive portwine stain (nervus flammeus)

Cavernous hemangioma is a relatively uncommon vascular anomaly of large, sinuslike blood vessels of skin. It appears as a raised, deep-seated, poorly demarcated purple spot that blanches on pressure (Fig. 30.19). Like capillary type, cavernous hemangioma too disappears in most cases in early childhood. This hemangioma may lead to hypertrophy of the involved limb.

Usually no treatment is required. If, however, a large hemangioma persists, it has got to be removed by carbon dioxide freezing, surgical excision and

grafting, cryosurgery and tattooing. Laser therapy, now emerging as the modality of choice, may be resorted to. Some cavernous hemangiomas may respond to a course of steroids followed by compression.

The complications in capillary or cavernous hemangioma include superimposed infection, trauma, ulceration, bleeding due to thrombocytopenia and rarely DIC. In some instances, arteriovenous fistulae may occur.

TELANGIECTATIC ANGIOMA (*Spider Nevus*)

It consists of a central dilated capillary with many radiating vessels and is most often found over the face.

Two types are known. First: *hereditary* (Osler-Rendu-Weber disease) in which mucous membrane lesions occur early in life followed later by skin lesions. GIT bleeding may occur. Second: *acquired* as in cirrhosis.

Treatment is freezing with liquid nitrogen or carbon dioxide, or diathermy electrocoagulation of the central area.

EPIDERMOLYSIS BULLOSA (EB)

This group of conditions is characterized by congenital blistering precipitated by mechanical irritation and high environmental temperature.

Epidermolytic EB is autosomal non-scarring form in which blisters may be present right at birth or in neonatal period (simplex type) (Fig. 31.20), or appear after first year of life especially over feet and hands (Weber-Cockayne type).

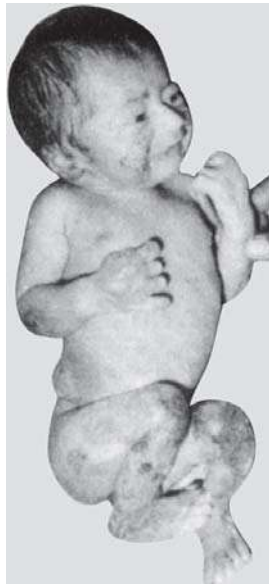

Fig. 31.20: Epidermolysis bullosa

Junctional EB also nonscarring, may be of milder autosomal recessive type (generalized atrophic type) or with life-threatening complications (letalis or herlitz type)

Dermolytic EB is characterized by scarring and may be of two types: (i) sominant dystrophic in which, besides rapidly healing blisters, involvement of nails is common and in some even mucous membrane may be affected, (ii) recessive dystrophic in which mucous membrane lesions are common, leading to nutritional deprivation; deformities of hands and feet may occur.

Affected children must be protected against mechanical trauma and heat, and superimposed infection and undernutrition. Genetic counseling is indicated.

ERYTHEMA MULTIFORME

The term refers to a disorder characterized by series of concentric circles. Corresponding to vasodilatation, edema and oozing of red cells, each circle is red, white and blue from outside to inside. Associated lesions may include pruritic erythematous half circles, polycyclic erythema, urticaria, bullae and erosions (Fig. 31.21). A severe bullous type involving skin, eyes, genitalia and mouth and with severe systemic manifestations is called *Stevens-Johnson syndrome* (Figs 31.22 and 31.23).

A wide variety of etiologic factors such as viruses, bacteria, fungi, vaccination and drugs (especially sulfas) have been implicated.



Fig. 31.21: *Erythema multiforme minor*. Note the symmetrical crops of skin lesions of diverse morphology with relative sparing of the mucous membranes



Fig. 31.22: *Erythema multiforme major (Stevens-Johnson syndrome)*. Note extensive involvement of the skin and mucous membranes, including purulent conjunctivitis and uveitis, as also toxic appearance



Fig 31.23: Stevens-Johnson syndrome during recovery. Note the healing skin and mucous membrane lesions

Treatment in simple erythema multiforme is removal of the offending agent, oral antihistaminic agents, cool compresses and wet dressing. Stevens-Johnson syndrome is an indication for parenteral nutrition, and administration of antibiotic(s) and steroids.

PEMPHIGUS

Pemphigus vulgaris is characterized by painful ulceration in the buccal cavity followed by large bullae (deep in the epidermis) over trunk and head. On slight pressure, avulsion of the epidermis occurs. This is called *Nikolsky sign*. The lesions rupture, leaving behind raw area which shows little inclination to heal (Fig. 31.24).

Pemphigus foliaceus is characterized by rather superficial blisters (high in the epidermis) which tend to rupture quickly, leaving behind crusts and scales. Scalp, face, neck and upper trunk are the common sites. Unlike pemphigus vulgaris, it is a relatively benign condition.

Treatment is with systemic steroids. Pemphigus vulgaris may need cyclophosphamide, azathioprine or gold salts for maintenance of the remission achieved with steroids.

EHLER-DANLOS SYNDROME

This genetic connective tissue disorder is characterized by hyperelasticity, fragility and easy bruising of the skin. Marked fragility of the skin is responsible for minor trauma resulting in ecchymosis, bleeding and



Fig. 31.24: Pemphigus. Note the large bullae, deep in the dermis, which, together with the oral ulceration, suggest “pemphigus vulgaris”

poor healing. Atrophic cigarette-paper scars over pressure points, legs and forehead are suggestive of the diagnosis (Figs 31.25A and B).

At least 10 forms of the syndrome have been described.

No specific treatment is yet available. Nevertheless, life expectancy is, as a rule, normal. A major complication like rupture of lung, bowel or great blood vessels may prove fatal. Remaining complications include skeletal deformities and ocular defects.



Figs 31.25A and B: Classical cigarette-paper scars in two subjects with Ehler-Danlos syndrome

MOLLUSCUM CONTAGIOSUM

It is a contagious and autoinoculable skin disease caused by the largest virus (poxvirus) and is characterized by multiple small white or pink tumor-like masses (pinhead to pea size) on face, trunk and intertriginous areas.

The well-circumscribed and umbilicated papules need to be differentiated from warts.

Treatment, in cases who fail to have spontaneous resolution in 6-9 months, is removal by curettage. It consists in expressing the cheese-like material with forceps followed by application of tincture iodine or carbolic acid. Liquid nitrogen therapy, electrocautery, cryotherapy and laser therapy too are available. Mild disease may respond to application of cantharadine, podophyllotoxin or trichloroacetic acid.

4 WARTS

This contagious disease is caused by human papilloma virus and is characterized by verrucose papules (common warts, *verruca vulgaris*) or flat lesions (plane warts) on anogenital region or elsewhere, say soles and subungual region.

If spontaneous resolution fails to occur in several months, treatment is local application of cantharadin or a keratolytic agent such as salicylic acid for 2-3 months or a physical removal by curettage, electrocautery, chemical cautery, cryotherapy and laser therapy. An expensive therapy in the form locally injectable interferon alfa too is available.

ERYTHEMA NODOSUM

The condition is characterized by appearance of painful erythematous (bright red) nodules on the shins. Occasionally there is involvement of forearms and rarely of calves, thighs and soles. At a time, not more than four nodules may be seen. The lesions fade in a week or two, leaving behind a brownish discoloration.

The condition is an allergic vasculitis and may be associated with tuberculosis, streptococcal sensitivity as in rheumatic fever, ulcerative colitis, Crohn disease, sulfonamide therapy, histoplasmosis and coccidiomycosis.

Treatment consists in giving bed-rest until all the lesions have subsided, application of topical steroid cream, oral steroids and removal of the offending agent or eradication of the underlying disease.

SKIN TUBERCULOSIS

It is discussed in Chapter 21 (Pediatric Pulmonology).

ECTODERMAL DYSPLASIAS

These are a group of conditions characterized by dominant involvement of ectodermal structures, e.g. skin, teeth, hair, nails, and endocrine and sebaceous glands.

Anhidrotic type, the commonest, is usually X-linked recessive though autosomal recessive inheritance may also occur. The triad of lack of or poor sweating (anhidrosis or hypohidrosis), anomalous dentition (usually widely-spaced peg-shaped teeth) and sparse hair (hypotrichosis) is characteristic of this type (Figs 31.26 to 31.28). Episodes of unexplained pyrexia are common.

Hydrotic (Clouston) type is manifested by hyperkeratosis of palms and soles, dystrophic nails and sparse hair. Sweating is normal. Dentition is usually not affected.

Robin type, an autosomal dominant disorder, is characterized by dystrophic nails, peg-shaped teeth and sensorineural deafness.

Rapp-Hodgkin type, an autosomal dominant disorder, manifests with poor sweating, dystrophic nails, sparse hair, oral clefts, hypospadias and growth retardation.



Fig. 31.26: Anhidrotic ectodermal dysplasia. Note the peg-shaped incisors



Fig. 31.27: Anhidrotic ectodermal dysplasia. Note the sparse scalp hair



Fig. 31.28: Anhidrotic ectodermal dysplasia

EEC syndrome, an autosomal dominant disorder, consists of ectodermal dysplasia (thin, dry skin, sparse hair, dystrophic nails), ectodactyly, and cleft lip and palate.

ACNE

Acne is a subacute or chronic inflammatory disorder characterized by appearance of pleomorphic lesions usually over the face and the trunk though, occasionally, arms, legs and buttocks may also be involved.

Several varieties of acne are recognized, namely acne vulgaris, infantile acne, steroid acne, halogen acne, tropical acne and acne conglobata.

Acne vulgaris, a sort of physiologic event occurring universally in adolescence with a slightly greater preponderance in males, is characterized by four basic types of lesions, i.e. early whiteheads or blackheads called "comedones", papules, pustules, and nodulocystic lesions with interspersed scarring. The lesions are usually confined to the face with predominance over the forehead (the so-called "promade acne" due to application of petroleum jelly or other greasy hair preparations). At times chest, upper back and deltoid areas are also involved.

A functional mature subaceous gland that enlarges and produces excessive sebum in response to increased activity of androgens during adolescence is the seat of acne lesions. Colonization with organisms, *Propionibacterium acnes*, *S. epidermidis*, and, perhaps, *Pityrosporon ovale*, sets up an inflammatory reaction in the comedone.

Treatment consists in clarifying to the adolescent as well as the parents that frequent cleansing, cosmetics, hair preparations and facial manipulations are harmful and must be avoided.

Among the topical preparations, benzoyl peroxide gels and retinoic acid (which reduce the *P. acnes* count and number of visible comedones) are most effective though sulfur, salicylic acid and resorcinol are also useful and acceptable for mild keratolytic effect.

Recommended topical antibiotics for infected comedones include clindamycin, erythromycin and tetracycline.

Topical therapy needs to be given for several weeks for perceptible outcome.

Together with topical therapy, systemic administration of erythromycin, tetracycline or some other suitable antibiotic is recommended for better results.

Physical therapy includes ultraviolet light (natural sunlight suffices), CO₂ snow or slush.

Surgical therapy revolves round extraction of open and closed comedones, needle aspiration of nodulocystic lesions, steroid injection into acne cysts, and dermabrasion to safeguard against scarring.

Chloracne results secondary to halogenated aromatic hydrocarbons (direct contact, inhalation or ingestion). The lesion are predominantly comedonal

and less frequently inflammatory (papules, pustules, nodules, cysts). Healing occurs by hypertrophic or atrophic scarring. Though antibiotics and benzyl peroxide are of little value, topical or oral retinoids are effective.

Neonatal acne, occurring in 20% of neonates, is characterized by comedones predominantly on cheeks and forehead. It may be due to placental transfer of maternal androgens, hyperactive neonatal adrenal glands and a hypersensitive neonatal endorgan response to androgenic hormones. It responds well to benzyl peroxide and tretinoin.

Infantile acne, resembling acne vulgaris except that nodulocystic lesions are infrequent and scarring is absent, may occur in first month of life in male children in particular as a hypersensitivity end-organ response to hormones. The lesions are confined to face. One or both parents have had severe acne during their adolescence. Predisposition to severe acne is quite likely.

Application of benzoyl peroxide or a mild acne lotion usually clears the lesions within a few weeks.

Steroid acne, a sort of monomorphous folliculitis over the face, neck, chest, shoulders, upper back, arms and, rarely, the scalp, follows 2 weeks after systemic or topical steroid therapy. Characteristically, erythematous papules or pustules in the same stage of development are seen. Comedones are infrequent and the nodulocystic lesions and scarring rare. Similar acne may occur in congenital adrenal hyperplasia as well.

Application of retinoic acid and benzoyl peroxide gel is effective.

Halogen acne, dominated by highly inflammatory lesions may follow administration of iodide or bromide-containing medications. Withdrawal of the medication with application of an anti-acne topical preparation regresses the lesions.

Tropical acne, characterized by dominantly suppurating nodulocystic lesions over the back, chest and buttocks, with superadded infection, is secondary to intense heat and humidity. Elimination of environmental factors is an essential prerequisite for successful outcome with acne therapy.

Acne conglobata, characterized by papules, pustules, nodules, cysts, abscesses, sinus tracts and severe scarring over body (relatively sparing the face) with constitutional symptoms and anemia, occurs in adolescents and adults.

Since routine acne therapy is usually ineffective, these subjects need systemic steroids or sulfones to suppress inflammation, and isotretinoin. The last-named agent is known for its teratogenic adverse effects.

Acne fulminans (acute febrile ulcerative acne) is characterized by abrupt development of extensive inflammatory (ulcerative acneform) lesions over the chest and back of the adolescent boys. Accompanying the lesions are constitutional manifestations in the form of fever, arthralgia, myalgia, loss of weight, debilitation and leukocytosis. The lesions spare the face and heal by scarring. Treatment is with oral steroids, isotretinoin, dapsone and antibiotics in the presence of superadded infection.

PSORIASIS

Psoriasis, a disease of unknown etiology, unknown inheritance and unknown pathogenesis, may occur in some 1% of children, usually in 3 to 10 years age group with predominance of girls. Rarely, it may occur in neonates—initially involving the diaper-area and later assuming a severe and recalcitrant form.

The classical lesions consist of red papules that coalesce to form plaques with sharply demarcated irregular margins and silvery scales (Fig. 31.29). Pinpoint hemorrhage follows removal of the scales. This is called Auspitz sign. The lesions show a tendency to appear at the sites of trauma, the so-called isomorphic or Koebner response.



Fig. 31.29: Psoriasis. Note that the lesions are in the process of healing

The lesions usually occur over scalp, knees, elbows, umbilicus and genitalia, and less often involve the face and nails. The lesion of the so-called *guttate psoriasis*, that may follow a streptococcal throat infection, viral infections, sunburn, and withdrawal of steroid therapy, are usually seen over trunk, face, and proximal portions of extremities.

Therapeutic measures include application of coaltar preparations, topical steroids, ultraviolet light/natural sunlight, *psoralens and ultraviolet light (PUVA)*, and high doses of vitamin D. Treatment is by and large only palliative.

FURTHER READING

Articles/Chapters

1. Gupte S. Hereditary ichthyosis. Experience with 50 pediatric subjects. *Indian Pract* 1987;40:961.
2. Gupte S. *Differential Diagnosis in Paediatrics*, (5th edn). New Delhi: Jaypee 2007.
3. Darmstadt GL, Sidbury R. Acne. In Kliegman RM, Behnman RE, Jenson HB, Stanton F (Eds): *Nelson Textbook of Pediatrics*, (18th edn). Philadelphia: Saunders 2004:2242.
4. Sarkar R, Basu S, Sharma RC, Dutta AK, Sardana K. An appraisal of pediatric dermatological emergencies. *Indian Pediatr* 2000;37:425.
5. Sobti PC, Dogra A, Dua A. Dermatological emergencies. In: Gupte S (Eds): *Textbook of Pediatric Emergencies*. New Delhi: Peepee 2005:516.
6. Webster GF: Acne vulgaris. *Br Med J* 2002;325:475.

Book/Monograph

1. Eichenfield LF, Frieden IJ, Esterly NE. *Textbook of Neonatal Dermatology*. Philadelphia: Saunders 2001.

CHAPTER



32

Pediatric Accidental Poisoning

Suraj Gupte, RK Kaushal

ACCIDENTAL POISONING: AN OVERVIEW

Accidental poisoning is an important cause of morbidity and mortality in childhood all over the world, the pattern and magnitude varies in different areas as also with changing times. Such mishaps are usually unintentional in children below 5 years with a peak occurrence around 18 months to 3 years due to exploratory behaviour, inability to discriminate safe versus unsafe agents and careless household storage of medicines and toxic substances like kerosene stored in water containers. Poisoning could be intentional, purposeful, may be with multiple agents and more common in girls than boys in children above 5 years and adolescents. Table 32.1 outlines the relative incidence of various accidental poisonings in hospitalized children India.

Table 32.1: Relative incidence of accidental poisoning in hospitalized children in India

Poisoning	Incidence (%)
Hydrocarbon (kerosene)	50
Household medicines	20
Household substances (insecticides, pesticides etc.)	20
Miscellaneous	10

Approach

The principles of initial approach are:

- Resuscitation and stabilization
- History and physical examination
- Appropriate decontamination: GIT, skin and eyes.
- Judicious use of laboratory tests, EKG and radiography

- Administration of specific antidotes
- Use of enhanced elimination techniques for selected toxins.

In the initial assessment, the attending doctor must rapidly decide whether a child is in a life threatening situation and standard ABCs of resuscitation is always the first priority. *The first step should be to treat the patient and not the poison.* The supportive measures are outlined in the Table 32.2.

Table 32.2: Salient features of initial/supportive therapy in poisoning

Indications	Corrective Measures
Airway obstruction and breathing difficulty	Keeping airway open by removing extraneous material, secretions. Bag and mask ventilation intubation, tracheostomy.
Peripheral circulatory failure	Oxygen administration Expansion of intravascular volume by suitable volume expander
Hypoglycemia	0.25 to 0.5 gm/kg 25% dextrose in water by i/v push
Electrolyte imbalance	Appropriate fluid and electrolyte therapy.
Cerebral edema	Mannitol
Seizures	Diazepam
Renal failure	Appropriate measures for ARF
Anemia, hemolysis	Blood Transfusion
Infection	Appropriate antibiotics

Next, take detailed history from the patient (if conscious), family members, friends or bystanders to identify the ingested substance, its amount,

concentration, route, time elapsed and nature of any treatment administered.

Perform brief physical examination with particular attention to any specific odor in the breath / vomitus and clothes, vital signs, sensorium (AVPU or Glasgow coma scale) and pupils. The positive findings of the physical examination may form a constellation of signs and symptoms referred to as toxidrome characteristic of exposure to a particular group of substances (Tables 32.3 to 32.6) show common symptoms, signs and toxidromes of poisoning in children.

Table 32.3: Examples of odors with various toxic agents

Odors	Toxic agents
Acetone	Acetylsalicylic acid
Garlic	Arsenic, organophosphate
Petroleum	Petroleum distillates

Table 32.4: Examples of the vital sign changes commonly associated with various toxic agents

Temperature	
<i>Hypothermia</i>	<i>Hyperthermia</i>
Barbiturates	Anticholinergics
Ethanol	Hallucinogens
Narcotics	MAO inhibitors
Phenothiazines	Salicylates
Sedative-hypnotics	Sympathomimetics
Heart Rate	
<i>Bradycardia</i>	<i>Tachycardia</i>
β-blockers	Anticholinergics
Calcium channel blockers	Ethanol
Clonidine	Methylxanthines
Cyanide	Sympathomimetics
Digitalis	Cyclic antidepressants
Organophosphates	
Sedative-hypnotics	
Blood Pressure	
<i>Hypotension</i>	<i>Hypertension</i>
Antihypertensives	Amphetamines
β-Blockers	Anticholinergic
Calcium Channel Blockers	Phencyclidine
Iron, Narcotics	Sympathomimetics
Sedative-hypnotics	Tricyclic antidepressants
Respiratory Rate	
<i>Hypoventilation</i>	<i>Hyperventilation</i>
Clonidine	Methanol
Narcotics	Carbon-monoxide
Organophosphates	cyanide
Sedative-hypnotics	Methylxanthines
Cyclic antidepressants	Salicylates
	Sympathomimetics

Table 32.5: Pupil changes associated with some toxins and drugs

<i>Miosis (COPS)</i>	<i>Mydriasis (AAAS)</i>
C—Cholinergics, Clonidine	A—Antihistamines
O—Opiates, organophosphates	A—Antidepressants
P—Phenothiazines, Pilocarpine, Pontine bleed	A—Anticholinergics, atropine
S—Sedatives—hypnotics	S—Sympathomimetics (Cocaine, amphetamines)

Table 32.6: Toxidromes suggestive of different groups of poisoning agents

Toxins	Syndromes
Opioids	Respiratory failure, coma, miosis
Cyclic-antidepressants	Coma, seizures, dysarrhythmias QRS > 0.10 sec
Cholinergics	Diarrhea, diaphoresis, urination, miosis
(Organophosphates and carbamates)	bronchorrhoea, bronchospasm, bradycardia emesis, lacrimation, salivation, vomiting, fasciculations.
Anticholinergics. (Atropine, phenothiazines, antihistamines, mushrooms)	Hyperthermia—hot as a hare Mydriasis—blind as a bat Dry skin and mucosae—dry as a bone Flushing—red as a beet. Delirium—mad as a hatter.
Sympathomimetics	Mydriasis, anxiety, tachycardia, hypertension, hyperthermia, diaphoresis

Laboratory Evaluation

No toxic panel is uniformly helpful. If cardiac rhythm disturbances are present obtain a 12 lead EKG, X-ray chest for aspiration pneumonia and pulmonary edema, serum electrolytes, ABG estimations may provide valuable information. Certain medications may be seen on abdominal radiographs (Tables 32.7 and 32.8).

Table 32.7: Laboratory tests that suggest poisoning

Abnormalities	Poisons
Hyperkalemia	Potassium, Digoxin
Hypokalemia	Theophylline, barium, diuretics
Hypoglycemia	Insulin, salicylates, propranolol, oral hypoglycemic agents
Hyperglycemia	Salicylates (early stages), theophylline, iron
Hypocalcemia	Salicylates
Ketonuria	Salicylates

Table 32.8: Radiopaque Ingestants (CHIPS)

C—Chloralhydrate, chlorinated hydrocarbons
H—Heavy metals
I—Iron, Iodides
P—Phenothiazine, Potassium
S—Slow release capsules/tablets

Gastrointestinal Decontamination

It is aimed to prevent absorption by gastric lavage, activated charcoal, cathartics and whole bowel irrigation. Syrup of ipecac induced emesis has no role in hospital setting.

Gastric Lavage

It is indicated only if the patient arrives within one hour (Golden hour) of ingestion, life threatening ingestions or for those substances that don't bind to charcoal (Table 32.9). Gastric lavage is done with large bore orogastric tube with 0.9% saline, 15 ml/kg (Max 200-400 ml/cycle). It is contraindicated in caustic, hydrocarbon and sharps ingestion.

Table 32.9: Toxins poorly bound by activated charcoal (CHEMICLS)

C—Cyanide
H—Hydrocarbons
E—Ethanol
M—Metals
I—Iron
C—Caustics
L—Lithium
S—Solvents

Activated Charcoal

It is a finely granular substance with a surface area of approximately 1000 m²/gm, its microscopic pores permit adsorption of drugs and other large molecular weight substances. Maximum adsorption of charcoal to toxin occurs when the charcoal to drug ratio is 10:1. Because of its effectiveness both in enhancement of preabsorptive and postabsorptive elimination, only modest benefit of gastric emptying and cathartic administration, charcoal has become the single most first line treatment for significant toxic ingestions.

It should be administered in a dose of 1 gm/kg (maximum 50-60 gm). When repetitive doses are required, it can be given in this dose every 4 hourly (or 0.5 gm/kg every 2 hours). Prepare activated

charcoal by mixing aqueous solution or its desiccated form with ice and add flavouring (cola or cherry syrup) if desired. Child can drink it from cup with a straw or instilled through orogastric tube. It is contraindicated in hydrocarbons, corrosive poisoning and in paralytic ileus.

Hyperosmolar adjunctive cathartics (sorbitol 70%) 0.5 gm/kg, 10-20 ml in children and 60-100 ml in adolescents, decrease the transit time but are contraindicated in children below 6 years because of potential risk of fluid and electrolyte imbalance.

Whole Bowel Irrigation (WBI)

It decontaminates the entire gut and is indicated for ingestants not bound to activated charcoal, e.g. Iron and slow-release drug preparations. WBI is accomplished through rapid administration of polyethylene glycol electrolyte lavage solution via nasogastric tube at a rate of 500 ml/hour in preschoolers and 1-2 liters/hr for teenagers. The end point is a clear rectal effluent. This procedure is contraindicated in patients with ileus, obstruction, perforation or significant gastrointestinal hemorrhage.

Toxin Elimination (Enhancement of Excretion)

Several techniques are employed like urinary alkalinisation (Iron-trapping) hemodialysis, peritoneal dialysis, haemoperfusion, exchange transfusion, plasmapheresis and drug antibodies (digoxin fab antibodies). These techniques are indicated only in a few situations. In theory, acidification and alkalinisation of urine enhance the excretion of weak bases and acids. The acidification should be avoided altogether because of the risks of acidemia and exacerbation of rhabdomyolysis. Urinary alkalinization should be considered for significant salicylate and phenobarbital poisoning. In significant lithium or bromide poisoning neutral diuresis can be induced by administration of excess intravenous crystalloids with contraindications of pulmonary and cerebral edema and renal failure.

Hemodialysis is indicated for methanol, ethylene glycol, significant salicylate, phenobarbital, theophylline and lithium poisonings. Charcoal hemoperfusion is rarely indicated and used most often in significant theophylline poisoning.

Administration of Antidotes

Antidotes and antagonists are available for only a minority of poisonings and should not be used indiscriminately because overuse may complicate initial presentation by producing other forms of poisoning. *Moreover the basic supportive care saves more lives than all the antidotes put together.* Specific antidotes are listed in Table 32.10.

Prevention

The parents need to ensure that;

- All medicines and chemicals are kept beyond the reach of children, preferably under lock and key.
- Drugs and medicines are dispensed in their original containers and administered under direct supervision and not without specific written prescription of the doctor.

Table 32.10: Antidotes used in toxicology

Toxins	Antidotes	Dosages
Anticholinergics	Physostigmine	0.02-0.06 mg/kg up to 0.5 mg slowly IV/IM/SC repeated at 5 minutes interval until desired effect (max 2 mg)
Acetaminophen	N-Acetylcystein	140 mg/kg PO or IVstat, Followed by 70 mg / kg × 17 doses (4 hrly)
Carbon monoxide	Oxygen	100% by tight fitting mask or hyperbaric oxygen
Cyanide	Sodium nitrite Sodium thiosulfate	0.33 ml/kg of 3% IV 1.65 ml/kg of 25% IV
Digoxin	Digoxin - specific Antibodies (Fab) fragments (Digibind - each vial binds approx 0.6mg of Digoxin)	Children less than 20 kg, 1 vial (total amount ingested in mg ÷ 0.6 = No. of vials)
β-blockers	Isoproterenol dopamine, epinephrine	Infusion, titrate to effect
Iron salts	Desferroxamine (Desferal 500 mg/vial)	(15 mg/kg/hr IV) until urine color normal or Iron level <100 pg/dl
Methemoglobin producing agents	Methylene - Blue (10 mg/ampoule)	1 -2 mg/kg IV (0.1-0.2 ml/kg 1% solution over 5-10 minuts may repeat after 4 hours.
Narcotics	Naloxone	0.01 mg/kg IV (max 2 mg). Repeat every 2-3 minutes till the reversal or cumulating dose of 10 mg.
Organophosphates	Atropine Pralidoxime	0.05 mg/kg IV every 10-30 min to achieve atropinization 25 - 50 mg/kg IV or IM as 5% solution 12 hours apart (if to be repeated)
Phenothiazines	Diphenhydramine (Benadryl)	0.5-1 mg/kg IV/IM (max 50 mg), may be repeated every 30 minutes
Isoniazid (INH)	Pyridoxine	1 mg/1 mg of INH ingested / (max I/V 500 mg)

- Potential household substances like kerosene, other petroleum distillates insecticides, pesticides are kept in their original containers and not transferred to empty containers used for food stuffs and must be labeled as “Poison” prominently.
- Infants and toddlers should not be left unattended.
- Parents should also be educated not to panic in case of ingestion of some nontoxic household substances. (Table 32.11)
- There is need to establish Poison control centers in each state/district in order to compile and disseminate information on management and promote research in this field.

Table 32.11: Nontoxic products

Shaving cream, shampoo	Toothpaste
Ballpoint ink	Deodorants
Bubble bath soaps	Lipstick
Birth control pills	Mosquito repellants
Candle	Pencil (Graphite)
Cosmetics, powders	Matches
Chalk	Saccharin
Cigarettes	Water Colors
Crayons	Incense

KEROSENE OIL POISONING

It is the most common accidental poisoning seen in pediatric practice in our as well as other tropical countries. Kerosene is an aliphatic (open chain), moderately toxic, low viscosity (<60 SSU) hydrocarbon posing significant hazard of aspiration and chemical pneumonitis. There is virtually no gastrointestinal absorption of kerosene. CNS toxicity results from hypoxia secondary to aspiration pneumonia. This could be enhanced by the volatility of kerosene at body temperature causing toxicity through inhalation and asphyxia by vapors. No CNS depression occurs in the absence of pulmonary complications. Fatal systemic absorption from topical exposure has been reported in very young infants.

Clinical Features

The earliest symptom is violent coughing and flushing of the face immediately following ingestion. In some instances kerosene may be vomited shortly after its

ingestion. One can usually find smell of kerosene from the mouth and vomitus. Older children may complain of headache, abdominal pain, dryness of throat. Fever is common. The occurrence of pneumonia in about 25% children is a troublesome complication. Any child with choking cough or vomiting at the time of ingestion should be considered to have aspirated until proved otherwise even if child appears asymptomatic in emergency department.

Treatment

Oxygen and respiratory support should be provided to the symptomatic children. Decontamination of the skin and removal of contaminated coverings avoids continued dermal absorption. Most of the children are asymptomatic and can be discharged safely after 6 hours of observation. Gastric lavage or induced vomiting is best avoided even in situations where large amounts defined in some texts as greater than 2 ml/kg have been ingested. Several studies have documented that as much as 20 ml/kg of kerosene can be safely ingested without systemic toxicity. Prophylactic antibiotics are of doubtful value; so are steroids.

ORGANIC PHOSPHATE POISONING

Accidental ingestion of organic phosphates, generally in the form of insecticides and pesticides (say Tik-20), is fairly common in childhood. They cause inhibition of cholinesterase, resulting in accumulation of acetylcholine and stimulation of CNS and parasympathetic system.

Absorption of organic phosphates occurs not only from mucosa but also from the skin.

Clinical Features

Within a few hours, the poisoning manifests in the form of blurred vision, headache, weakness, diarrhea, pain in the abdomen and chest, and nausea. Pulmonary edema and respiratory distress may result from excessive secretions in the lungs. Salivation and sweating are profuse. Muscle twitching, convulsions, loss of reflexes and coma may occur in advanced cases. Sphincter control is lost by many patients.

A remarkable finding is the constriction of the pupils and, at times, papilledema.

Diagnosis, though nearly always clinical, may be confirmed by reduced red cell cholinesterase.

Treatment

As soon as the diagnosis is reached, stomach wash should be done with soap and water. Remember never to give morphine.

Complete atropinization is, however, the specific treatment. The initial dose is 0.03 to 0.04 mg/kg to be given intravenously. Half of this dose needs to be repeated every 15 to 30 minutes until pupils begin to dilate (mydriasis), mouth becomes dry and tachycardia results.

Along with atropinization, it is necessary to administer pralidoxime intravenously. The dose is 25 to 50 mg/kg which should be injected over a 5-minute period slowly.

Supportive measures, including oxygen, artificial respiration and postural drainage of secretions, may be warranted in serious cases.

DDT POISONING

Poisoning from DDT (dichloro-diphenyl trichloro-ethane), a white powder with mild smell, is quite frequently encountered in childhood. Despite its having been recently condemned as an "environmental pollutant", its benefits in health programs outweigh its hazards and it continues to be widely used for spray in the houses against malaria and other diseases.

Clinical Features

Accidental swallowing of DDT causes serious neurologic manifestations. These include confusion, tremors, incoordination, convulsions and paresthesia involving lips, tongue and face.

Treatment

It is purely symptomatic. Control of convulsions with phenobarbital or diazepam should be immediately achieved.

As yet there is no specific antidote for DDT poisoning.

BARBITURATE POISONING

Unlike the experience reported from the western countries, accidental barbiturate poisoning is not a frequent pediatric emergency in our set up.

Clinical Features

The most usual presenting feature is "considerable drowsiness". Vomiting is common. Restlessness and flushing are occasionally seen.

A serious case may present in coma with respiratory depression and renal shutdown. Shock, cyanosis and pulmonary complications may also be present.

Treatment

Majority of the children with barbiturate poisoning respond well to simple gastric lavage. Presence of cyanosis is an indication for oxygen inhalation.

Intravenous fluids are indicated in the presence of shock, acidosis or renal failure. Rarely, a resort to peritoneal dialysis becomes necessary. Respiratory stimulants, like bemegride, are no longer recommended in the management.

Severe respiratory difficulty may need tracheostomy to maintain an open airway.

PARACETAMOL TOXICITY

With increasing use of paracetamol as an analgesic/antipyretic agent, the incidence of its toxicity has geared up. Almost always, significant toxicity occurs in children above 6 years of age. Mercuric acid conjugate, a metabolite of paracetamol, is the central factor in causing toxicity.

Four clinical stages of paracetamol toxicity are recognized:

Stage I : It lasts from 1/2 to 24 hours after ingestion and is characterized by anorexia, nausea, vomiting, pallor, lassitude and diaphoresis.

Stage II : It lasts from 1 to 2 days after ingestion and is characterized by resolution of manifestations of stage I and appearance of pain in the upper abdomen, oliguria and liver dysfunction (raised serum bilirubin, FT, SGOT, SGPT).

Stage III : It lasts from 2 to 4 days after ingestion and is characterized by reappearance of anorexia, nausea, vomiting and pallor, plus peak liver dysfunction.

Stage IV : It lasts from 4 days to 2 weeks after ingestion and is characterized by resolution of liver dysfunction. In a

suspected case of paracetamol toxicity, plasma level should be measured at 4 or more hours following ingestion. Once the diagnosis is established, serum bilirubin, SGOT, SGPT and FT evaluation must be followed daily.

The antidote of choice is N-acetyl-L-cysteine (NAC) best given within 16 hours after ingestion and in no case beyond 24 hours. In view of the significant higher incidence with intravenous infusion of hepatotoxicity, it is administered orally as a loading dose of 140 mg/kg followed by 70 mg/kg at 4-hour intervals for 17 additional doses.

Prognosis in treated cases is excellent. Even with serious hepatotoxicity, complete recovery occurs in 99.5% cases.

4 IBUPROFEN TOXICITY

With increasing use of the anti-inflammatory agent, ibuprofen, it is likely to be involved in overdoses (both accidental and intentional), leading to toxicity and poisoning in children. Normal blood levels at 2 hours of ingestion are 70 to 100 mcg/ml. If the level is 80 to 200 at 3 hours, mild gastrointestinal manifestations occur. At a 2-hour level of 360 mcg/ml, serious toxicity occurs. A dose of over 100 mg/kg is likely to be toxic.

Clinical Features

Manifestations of toxicity include nausea, epigastric pain, upper gastrointestinal bleed, lethargy, apnea, drowsiness and coma. Renal failure, hypotension, nystagmus, diplopia, tinnitus, deafness, headache, acidosis and remarkable elevation in serum potassium and creatinine and blood urea nitrogen are encountered in some cases.

Occasionally, ibuprofen may cause anaphylactoid reactions in the form of circulatory collapse, pruritus and angioedema.

Treatment

The patient must be provided good supportive care for respiration, cardiovascular system and coma.

Emesis and/or gastric lavage together with charcoal hyperperfusion, dopamine in case of hypotension, and hemodialysis are of benefit.

Since 90% ibuprofen is protein-bound, alkaline diuresis is of no value.

ASPIRIN POISONING (*Salicylism*)

Incidence of accidental aspirin poisoning in the developing world as well is on the increase.

In a child with such a poisoning, the blood salicylate level is usually above 40 mg%.

Clinical Features

The most remarkable feature of aspirin poisoning is what has come to be designated as *air-hunger*. Respiration is deep and rapid without a pause. This picture contrasts with the short and grunting breathing seen in case of pneumonia. Nausea, vomiting, tinnitus and fever may also be present.

Eventually, the child becomes cyanotic. A full-fledged peripheral circulatory failure may develop. Twitching, convulsions, rigidity and coma are often the terminal events.

Treatment

It includes measures such as "induced vomiting" and/or gastric lavage, oxygen inhalation, intravenous drip and peritoneal dialysis.

Some workers have reported excellent results following exchange transfusion.

PHENOTHIAZINE TOXICITY

In recent years, an increasing number of children are being reported to hospitals with neurologic manifestations following administration of trifluopromazine, prochlorperazine, chlorpromazine or some other phenothiazine. These drugs may produce toxicity in therapeutic as well as toxic doses.*

Concomitant administration of chloroquine, amodiaquine, metoclopramide, haloperidol, phenytoin, diazoxide, lithium, reserpine, chlorprothixene as also presence of dehydration boosts the risk of phenothiazine toxicity, both in frequency and severity.

* Phenothiazines can also produce dangerous hypersensitivity reactions like agranulocytosis, hepatitis and dermatitis

Clinical Features

Clinical picture is dominated by acute onset of signs and symptoms pertaining to extra pyramidal system. The characteristic features are choreiform movements, torticollis, muscle rigidity, opisthotonos, marked deviation of eyes and oculogyric crisis. Trismus, swallowing difficulties, drooling, tremors and ataxia may also occur. Convulsions and coma are rare.

Treatment

Diphenhydramine hydrochloride, 2 mg/kg (maximum 50 mg total), given slowly by intravenous route over a period of 3 to 5 minutes, is a highly effective antidote. Dramatic response occurs after the injection in a large majority of the cases. This agent is effective orally either but the response is rather slow.

Promethazine 0.5 mg/kg, given intramuscularly, is another useful agent.

Administration of 0.5 mg of *physostigmine* intravenously, over a period of 5 minutes also gives gratifying results. It acts through its anticholinesterase property.

More recently, parenteral diazepam has yielded excellent results.

CHLOROQUINE-INDUCED PSYCHOSIS

Infrequently, chloroquine, irrespective of the dose, may induce transient psychotic manifestations.

Manifestations include change in sensorium, confusion, disorientation, outbursts of violence and aggressive behavior, and hallucinations, including the visual ones in the form of the so-called *Alice-in-Wonderland* syndrome.

Following withdrawal of chloroquine, complete reversal of the manifestations results within hours to days. There is no residual symptom. Administration of diazepam speeds up recovery.

CYPROHEPTADINE POISONING

Cyproheptadine has therapeutic dose of 0.25 mg/kg/day, toxic dose 4 to 8 times the therapeutic dose and fatal dose 25 to 250 mg/kg.

Large doses may cause two opposing syndromes. Depression may occur in the form of drowsiness, disorientation, staggering, hallucination, stupor and

coma. Stimulatory manifestations may include excitement, fever, hyperreflexia, nystagmus and seizures.

Treatment consists in administering chlorpromazine, neostigmine and, in case of seizures, diazepam along with stomach wash and intravenous fluids.

Prognosis, following timely and appropriate treatment, is gratifying.

IRON (IRON SALTS) POISONING

Accidental ingestion by the baby of a large number of medicinal iron tablets, often available in the house for the use of the mother, is a common problem.

The lethal dose of elemental iron is about 250 mg/kilogram.

Clinical Features

The earliest manifestations are vomiting and diarrhea due to irritation of the gastric mucosa. Gross damage to the gastric mucosa may cause severe gastrointestinal bleeding resulting in hematemesis and bloody diarrhea.

Shock, CNS depression and hepatic or renal failure may occur within few hours or after a day or two.

Incidence of pyloric stenosis as a late sequel is high.

Treatment

Immediately on diagnosis, vomiting should be induced and stomach wash done with sodium bicarbonate (NaHCO₃).

For shock, an intravenous drip is started. A careful monitoring to maintain fluid, electrolyte and acid-base balance is essential.

The antidote of choice is desferrioxamine, 90 mg/kg/day in 4 to 6 divided doses intravenously or intramuscularly. The total calculated dose may well be given by intravenous or subcutaneous drip in 12 to 24 hours. The drip method has, in fact, proved to be most effective.

If desferrioxamine is not available (which is usually the case in our country), give the patient 12.5 mg/kg of calcium EDTA intramuscularly.

Occasionally a dialysis or exchange transfusion may become necessary.

MORPHINE AND OTHER OPIATES POISONING

It can occur in three ways: (i) accidental ingestion of large dose, (ii) excessive therapeutic administration, and (iii) breastfeeding by a mother taking the agent.

Clinical Features

The salient clinical features are respiratory depression, change in sensorium to the extent of coma, pinpoint pupils and vomiting.

Treatment

Specific antidote is *nalorphine*. It should be given in a dose of 0.1 mg/kg stat.

Other measures include stomach wash with potassium permanganate and oxygen inhalation.

Clinical Features

Transient abdominal pain, resistant anemia, loss of weight, irritability, vomiting, constipation, headache, personality changes and ataxia are its common symptoms.

Poor physical development, seizures, and raised intracranial pressure leading to coma (*lead encephalopathy*) are rather late manifestations. A *lead line* in the gums is characteristic.

Diagnosis

Urine lead level of more than 80 mcg/dl/24 hours is diagnostic of lead poisoning.

Blood lead level in symptomatic cases usually exceeds 80 mcg/dl.

Urinary coproporphyrins or red cell aminolevulinic acid dehydrase levels are also good screening tests.

Peripheral blood film shows normocytic-hypochromic anemia with reticulocytosis and basophilic stippling of RBC.

X-rays may reveal opaque flakes in the GIT. Screening of the bony skeleton may show a lead line at the metaphyseal areas.

CSF pressure, proteins and cell count are moderately raised.

Treatment

In case of sudden massive ingestion of lead, it is advisable to induce vomiting followed by administration of a saline cathartic.

Specific treatment is a combination of dimercaprol (BAL), 4 mg/kg/dose every 4 hours intramuscularly, and calcium EDTA, 12.5 mg/kg/dose every 4 hours intramuscularly or intravenously. After 2-day therapy with these drugs, there is need to stop them and give penicillamine, 25 mg/kg/day orally for 5 days.

Remember that chelating therapy is not indicated when lead levels are below 60 mcg/dl unless indicated by an additional evidence of lead toxicity.

In case of encephalopathy, anticonvulsants, mannitol and/or steroids are indicated.

Do not use BAL in presence of hepatic insufficiency.

Do not give iron while therapy with BAL is in progress.

4

DATURA (ATROPINE) POISONING

Clinical Features

These include flushing of the face, dry skin and mucous membrane, dilated pupils, blurring of vision, fever and tachycardia. Initially the patient is restless but soon goes into depression, shock and coma. Respiratory collapse may occur. Retention of urine is common. Many patients develop abdominal distention.

Children with atropinism have been described as "red as beet, dry as bone, and mad as a hatter".

Treatment

Specific antidote is physostigmine, 0.5 to 2.0 mg stat. It can be repeated every half an hour if needed.

Other measures include induction of vomiting and/or stomach wash, control of fever by hydrotherapy and/or antipyretics, sedation to calm down the patient and catheterization in case of prolonged retention of urine.

LEAD POISONING (*Plumbism*)

It usually occurs in children suffering from pica involving ingestion of lead paint flakes, artist's paints, etc. from inhalation of fumes from batteries and from practice of employing *kajal* or *surma* containing black oxide of lead in eyes.

Remember too that a high calcium, high phosphorus diet and massive doses of vitamin D are of value in removing lead from blood and depositing it in the bones.

MERCURY POISONING

Mercury poisoning may be acute or chronic and reversible or irreversible, depending on the compound and extent of exposure. It may occur from excessive inhalation of the mercurous vapors, oral intake or repeated contacts with mercury-containing products like paints, wall-papers, diaper rinses, etc.

Acute mercury poisoning is characterized by predominantly gastrointestinal and renal manifestations. In exposure to high concentration of mercury vapor, manifestations include pulmonary irritation or pneumonitis, nausea, vomiting, diarrhea, abdominal pain and headache.

In oral exposure to mercury, manifestations include stomatitis, gingivitis, esophagitis, gastroenteritis with considerable salivation, abdominal pain and bloody diarrhea. In case of renal damage, albuminuria, and uremia may develop. CNS manifestations like ataxia, slurring of speech, visual and hearing impairment, numbness of hands and feet and delirium may occur.

Treatment consists of removal of mercury in stomach by gastric lavage (first with milk and then with sodium bicarbonate), correction of fluid and electrolyte imbalance, peritoneal or hemodialysis for acute renal failure, and symptomatic measures for restlessness and tachycardia. Specific antidote is dimercaprol or BAL (British antilewisite). Alternatively, penicillamine is recommended in case of adverse reactions to BAL.

Chronic mercury poisoning is characterized by predominantly CNS and skin manifestations. It is rare in children. Acrodynia and Minamata disease are two well-recognized forms of pediatric chronic mercury poisoning.

Acrodynia (Pink disease) is an unusual reaction to repeated ingestion of or contact with mercury. The clinical appearance and course of the disease are very characteristic. Extreme hypotonia, photophobia, pinkish color of extremities with hands and feet which are often painful, and marked dejection and

melancholia are the outstanding features. Urinalysis shows presence of mercury.

The disease runs a prolonged course, some patients dying especially as a result of superadded infections.

Treatment is difficult. Administration of BAL (British antilewisite), steroids and sedation, and symptomatic measures are of value.

Minamata disease is caused by ingestion of contaminated fish and shell fish. Between 1953 and 1966, it occurred in epidemic proportion in certain towns facing Minamata Bay in Japan.

Manifestations include disturbances in hand coordination, gait and speech, chewing and swallowing difficulties, visual blurring, tremors, rigidity, seizures and cloudiness of consciousness. Occasionally, impaired hearing and constriction of visual field may occur.

In congenital form, resulting from fetal poisoning from the mother who has eaten contaminated fish, more severe and widespread brain damage may lead to physical, motor and mental retardation, abnormal movements, or lack of smoothness of movements.

Besides symptomatic treatment in the form of anticonvulsants and good nourishing diet, BAL is effective in removing systemic mercury from the body.

The CNS damage being irreversible, survivors need rehabilitation, re-education and long-term care.

LATHYRISM

Lathyrism, a crippling neurologic disease, results from excessive consumption of a wild pulse (legume), lathyrus sativus, which is popularly known by such names as *khesri daal*, *teora daal* or *lakh daal*. The pulse looks like *Bengal gram* or *red gram daal* and is consumed by the poor for economic reasons, or is used for adulteration of relatively expensive *Bengal gram daal*. The disease is reported mainly from India (especially central and northwestern parts where it is a public health problem) and Bangladesh though Greece, Germany, Russia, France, Spain, Syria, Italy, Algeria, Abyssinia, Iran and Afghani-stan are also on record for its existence. The basic causative factor for neurologic manifestations in the pulse is a neurotoxin, *beta oxalyl amino alanine* (BOAA), though several

additional toxic factors are also contained in the seed. For development of lathyrism, it is necessary that the pulse is consumed in a large quantity (30 to 40% of total dietary intake) over a prolonged period (2 to 6 months).

Lathyrism has a greater tendency to inflict the children and youth, especially the males.

Manifestations include a progressive spastic paralysis of lower limbs.

A ban on cultivation of the pulse is the only sure method of prevention. Alternative recommendations are an intensive educational campaign against consumption of the pulse, and, if consumption becomes unavoidable, removal of the water-soluble toxin by simple measures such as parboiling or soaking the pulse in hot water and draining away the soaked water.

FURTHER READING

Articles/Chapters

1. Amir M, Khan KA, Ahmad SH. Siquil dystonia and chloroquine. *Indian Pediatr* 1976;13:733-735.
2. Arya LS, Quereshi MA, Jabor A, Singh M. Lathyrism in Afghanistan. *Indian J Pediatr* 1988;55:440-441.
3. Bhatia RK, Gupte S. Phenothiazine idiosyncrasy and poisoning. A report of 10 cases with review of literature. *Med and Surg* 1974;13:3-8.
4. Bryant S, Singer J. Management of toxic exposure in children. *Emerg Med Clin North Am* 1983;48:705-709.
5. Gupte S. Chloroquine-induced psychosis. *Abstracts 8th Asian Congress Pediatrics*, New Delhi, 1994-Abs No. FP08/7.
6. Gupte S. Dystonic reactions following metoclopramide therapy. *Indian J Pediatr* 1982;49:291.

Book/Monograph

1. Singh UK, Layland FC, Suman S, Prasad R: *Poisoning in Children*, (3rd edn). New Delhi: Jaypee 2002.



Pediatric Envenomations

Suraj Gupte, RK Kaushal

SNAKE BITE

Snake bite is a common emergency, particularly among children living in slums and villages. Three types of poisonous snakes encountered in India are:

1. **Neurotoxic** Cobra which causes paralysis of muscles of eyes (ptosis in particular), palate, jaws, tongue, larynx, neck, deglutition and chest, eventually leading to respiratory failure. Cardiotoxicity (hypotension, tachycardia, ECG alterations) and hemolysis may also occur. Onset of manifestations is rapid.
2. **Hemorrhagic hemotoxic** Viper which causes tissue destruction, hemorrhage and has relatively slow onset of symptoms.
3. **Neurohemotoxic** Krait which contains both neuro and hemotoxins. It is the most common and dangerous poisonous snake in India.

Clinical Features

Clinical symptomatology of snake bite is termed as "ophitoxemia". Any snake (poisonous or non-poisonous) may cause shock. Snake bite apart, the sheer appearance of a snake may be frightening. Locally there may be just fang marks and even bruises and lacerations, oozing of serosanguinous fluid in case of viper bites, pain, swelling, redness and numbness at the site of bite.

Constitutional symptoms appear after about 15-30 minutes of bite and include headache, dizziness, vomiting, CNS stimulation, convulsions followed by depression, respiratory difficulty and various paralyses. Hemorrhage from different sites and circulatory collapse may occur. Hemorrhagic sign is

most dreaded manifestation which includes bleeding from fang punctures, venepuncture sites, ecchymosis, epistaxis, bleeding gums, subconjunctival and intracranial bleeding. Intracranial bleed is the usual cause of death within 24-48 hours.

Laboratory Investigations

Laboratory investigations are useful only for monitoring the patient. Baseline investigations should include hemoglobin, complete blood count, platelet count, clotting time, prothrombin time, partial thromboplastin time, blood urea nitrogen, creatinine, CPK and ECG. Anemia, thrombocytopenia, leucocytosis, hypofibrinogenemia, proteinuria, azotemia, ST-depression/elevation, T inversion, QT prolongation and arrhythmias are common abnormalities. Immunodiagnosis by ELISA is useful (if available) to detect specific snake venom in wound aspirate, serum or other body fluids.

Grading of Envenomation

Clinically and on investigations, envenomation may be graded as per Box 33.1.

Box 33.1 : Grading of envenomation in snake bite

Grade 0	Nil
Grade 1	Minimal, with local swelling and pain that does not progress.
Grade 2	Moderate, with swelling, pain or ecchymosis progressing beyond the location of bite and also mild systemic and laboratory abnormalities.
Grade 3	Severe, with remarkable local response, severe systemic findings and significant alteration in laboratory tests.

Treatment

Immediate Measures

These should be directed at allaying fear, treating shock and respiratory failure with all available means. Patient should be kept recumbent, quiet and reassured. Only 25% of the snakes are considered poisonous. Wound should be cleaned with saline/water. During transportation to the hospital, to prevent absorption of toxin, a tourniquet is applied proximal to the bite about 5 cm above the upper limit of swelling which allows one finger beneath. It should be left *in situ* as long as antivenin serum (AVS) is not given. The bitten part should be immobilized and placed in a dependent position.

Specific Measures

4 Definitive indications for AVS are listed in Table 33.1.

Presence of fang marks, local pain, edema, swelling, numbness and weakness indicate the envenomation and AVS must be administered without loss of time after a test for hypersensitivity. Children require much larger dose since there is higher concentration of venom in terms of body weight. The dose varies from 50 to 200 ml or even more. It is given as intravenous infusion by reconstituting with distilled water or normal saline and diluted with 3 volumes of glucose saline beginning at the rate of 1 ml/minute and increased slowly as tolerated (usually 20 ml/kg/hour). Ideally AVS should be given as early as possible but it may be efficacious even up to 1 week after the bite. Injection of a part of antiserum locally is unnecessary; so are direct application of ice, local incision and oral suction. Concurrent administration of steroids and antihistamines reduce the risk of anaphylaxis due to antivenin.

Table 33.1: Definitive indications for AVS in snake bite

- *Systemic envenomation:* Bleeding, DIC, shock, ARF, neurotoxicity
- *Swelling over snake bite site:* Progressively spreading or bleeding

AVS hypersensitivity may be tested by the following methods:

- History of allergy to AVS or some other horse serum in the past.
- Skin test by intradermal injection of 0.1 ml of 1:100 saline dilution of AVS. Hypersensitivity is indicated by appearance of a wheal of > 10 mm in 10 to 30 minutes
- Conjunctival test by instilling one drop of 1:10 dilution in saline in lower conjunctival sac. Hypersensitivity is indicated by development of conjunctivitis and tears in 10 to 30 minutes.

Desensitization

Desensitization is carried out by intradermal injection of 0.1 ml of 1:100 saline dilution of AVS. Every 15 minutes the injection is repeated with a gradually increased dose of AVS until dose of 1 ml SC is given. This is followed by administration of 0.1 ml of undiluted AVS which again is built up to 1 ml gradually. If all goes well 10 ml

AVS diluted in 500 ml of N/S is infused IV by slow drip. Subsequently total calculated dose is administered carefully and one should be prepared to manage anaphylaxis.

Supportive Measures

Prophylaxis against tetanus and gas gangrene should be given. Antibiotics are needed in the presence of superimposed infection. Fresh blood or fresh frozen plasma for bleeding manifestations, restriction of fluids and electrolytes in ARF and surgical debridement in case of gangrene may be needed.

Prevention

Over all mortality due to snake bite is about 10%. In snake infested areas, use of boots, socks, trousers and torch may prevent snake bites.

Complications

Box 33.2 lists the common complications of snake bite.

Box 33.2: Complications of snakebite

- Compartment syndrome characterized by *six Ps, namely:*
 - Pain out of proportion to injury
 - Pressure symptoms in the form of swollen part
 - Paresthesia
 - Pulses being absent
 - Pain with passive stretch
 - Paresis/paralysis.
- Tissue necrosis (Fig. 33.1)
- Bleeding diathesis.



Fig. 33.1: Snake bite. Note the hematoma over the site of bite

SCORPION STING

Two species of scorpion namely *Mesobuthus tomulus* and *Palamneus swammerdani* are poisonous in India. Scorpion venoms are species-specific complex mixtures of short neurotoxic proteins containing free amino acids, serotonin, hyaluronidase and various enzymes. Voltage dependent ion channels are altered by the venom resulting in alpha receptor stimulation. It is responsible for autonomic storm. Local inflammation is unusual in Indian red scorpion envenomation.

Clinical Features

Species differences, venom dose/weight relationship determine the toxicity and clinical picture. Symptoms progress to a maximal severity in about 5 hours and subside within 24-48 hours. Based on symptomatology the stings can be divided into benign, potentially dangerous and invariably fatal.

Benign stings: Extreme local pain within seconds to minutes and little or no reaction at sting site. Serotonin found in the scorpion venom is responsible for pain.

Tap test: Severe pain by tapping over the sting site is often seen in Indian patients, however some children complain of pain at the site during recovery or paresthesia around the sting. Patients with severe local pain often don't have further progression of symptoms.

Potentially Dangerous Sting

It is characterized by features of "autonomic storm". Cholinergic stimulation (hypovolemia) merges imperceptively into adrenergic stimulation (ionotropic phase) and if treated properly the recovery follows in next 48-72 hours, Table 33.2 shows features of autonomic storm.

Table 33.2: Clinical features of autonomic storm in potentially dangerous scorpion stings

Mild pain, paresthesia vomiting, sweating salivation	} → Hypovolemia
Priapism, cool limbs Tachycardia Hypertension	→ Ionotropic phase
Myocardial dysfunction, arrhythmia, shock	→ Pulmonary edema.

Fatal Sting

These patients have predominant CNS manifestations within 1-2 hours of sting. It occurs infrequently but invariably fatal. Encephalopathy, convulsions, aphasia hemiplegia, cerebral hemorrhage, DIG and central respiratory failure have been reported. Aggressive supportive measures may reduce the mortality.

Treatment

The treatment should be directed to relieving pain, anxiety, suppress autonomic storm, correction of hypovolemia and pulmonary edema. Antivenom against the toxins of Indian scorpions is not available for clinical use. Moreover, wherever available, it may not alter the course if given 30 minutes or more after the sting, since scorpion venom reaches the target tissues too rapidly to be neutralized.

Prazosin, a competitive postsynaptic alpha, adreno receptor antagonist, is the first line management, since time lapse between the sting and prazosin administration for control of autonomic storm symptomatology determines the outcome. It reverses the metabolic and hormonal effects of alpha receptor stimulation and thus it is a cellular and pharmacologic antidote to the actions of scorpion venom in addition to being cardioprotective. Dose recommended is 30 microgram/kg/dose. It may be repeated after 3 hours and then every 6 hours till improvement. Monitoring of vitals is essential. Prazosin should be given only if

the clinical features suggest autonomic storm and not prophylactically. If only pain is present hypovolemia should be corrected immediately before giving prazosin.

Pain can be relieved with NSAIDs, local ice packs, 2% xylocain or dehydroemetine locally. Diazepam is useful to quieten the restless child. Always anxiety and in turn prevents myocardial stress.

Encourage oral fluid intake and give IV fluids judiciously to avoid hypovolemia as well as pulmonary edema. CVP line is essential.

Pulmonary edema should be treated by relieving afterload without compromising preload by diuretics, dobutamine (5-15 $\mu\text{g}/\text{kg}/\text{minute}$) and vasodialators, sodium nitroprusside (0.3-5 $\mu\text{g}/\text{kg}/\text{minute}$) or nitroglycerine (5 mg/min) infusate.

4 It is worthwhile to mention that lytic cocktail, morphine, steroids, atropine nifedipine and ACE inhibitors are not helpful and some of them may worsen the condition. The mortality has decreased dramatically from 30% to below 3% in good centers after introduction of prazosin as the first line treatment.

FURTHER READING

Articles/Chapters

1. Arora A. Snakebite. In Gupte S (Ed): *Recent Advances in Pediatrics (Special Vol 14: Criticare Pediatrics)* New Delhi: Jaypee 2004:480-501.
2. Bawaskar HS, Bawaskar PH. Clinical profile of severe scorpion envenomation in children at rural setting. *Indian Pediatr* 2003;40:1072-1075.
3. Bhatia BD. Scorpion sting and snake bite. In Sachdeva HPS, Puri RK, Bagga A, Choudhury P (Ed): *Principles of Pediatric and Neonatal Emergencies*. New Delhi: Jaypee 1994: 257-260.
4. Gupte S, Bansal A. Snakebite. In Gupte S (Ed): *Textbook of Pediatric Emergencies*. New Delh: Peepee 2005:382-385.
5. Kulkarni ML, Vijay Kumar KM, Snake bite. In Gupte S (Ed): *Recent Advances in Pediatrics (Special Vol: Tropical Pediatrics-2)*. New Delhi: Jaypee 1999:394-410.
6. Mahadev S. Scorpion sting. *Indian Pediatr* 2000;37:504-513.

Book/Monograph

1. Huxley S. *Envenomations* (3rd edn). London: Smith and Smith 2007.

CHAPTER



34

Pediatric Endocrinology

Suraj Gupte, AW Koff

THE ENDOCRINE ORCHESTRA

The endocrinal system has been aptly compared to an *orchestra*. The hypothalamus acts as the *master* or the *director* whereas the pituitary gland is the *conductor* in this endocrine orchestra. The *conductor* is subservient to “not just the hypothalamus”. It is also controlled by the *feedback* from the glands that it stimulates.

At no other span of life the endocrines and their metabolic and biochemical effects are more vital than in infancy and childhood. This is more so since stimulation of physical as also sexual growth is a unique feature of this age.

HYPOTHALAMUS AND ITS DISORDERS

Hypothalamus occupies a unique anatomic as well as functional position. At least five hypothalamic-release factors, namely ACTH, GH, TSH, FSH and LH, have been recognized. These factors regulate the activity of anterior and intermediate pituitary glands. Secondly, it produces two neurohormonal substances, namely *vasopressin* (antidiuretic in action) and *oxytocin* (stimulates milk secretion and uterine contractions).

Diabetes insipidus is the most common disease that results from the involvement of the neurosecretory system. It is characterized by an inability to concentrate urine, polyuria and polydipsia.

Vasopressin sensitive diabetes insipidus It is a chronic disease that results from a defect of the neurohypophyseal system. It is characterized by an inability to concentrate urine, polyuria of 5 to 20 liters/day and corresponding polydipsia. Polyuria may disturb sleep. Polydipsia may be as severe as to lead the patients to resort to drinking their own urine at

times. Restriction of free fluid intake may lead to severe dehydration, dyselectrolytemia and weight loss.

The operative defect is deficiency of antidiuretic hormone, *arginine vasopressin*. Hence, the new nomenclature *vasopressin sensitive diabetes insipidus*.

The causes of neurohypophyseal damage include craniopharyngioma, optic gliomas and other tumors, histiocytic infiltration, reticuloendotheliosis, leukemia, encephalitis, tuberculosis, sarcoidosis, actinomycosis, operative procedures or trauma about the base of skull. The genetic forms of the disease (autosomal dominant and X-linked recessive) are also known.

Investigations show 24-hour urine output as high as 4 to 10 (or even more) liters, the specific gravity varying between 1001 and 1005 and the osmolality 50 and 200 mOsm/kg water. The 3-hour water deprivation may cause rise in plasma osmolality through the urine osmolality. Radioimmunoassay, showing vasopressin plasma level below 0.5 pg/ml, is a highly sensitive and more dependable test.

Differential diagnosis is from *nephrogenic diabetes insipidus* (also called *vasopressin insensitive diabetes insipidus*) compulsive water drinking (psychogenic polydipsia), hypercalcemia, potassium deficiency and chronic renal disorders.

Whereas the real treatment should be directed at the underlying cause, symptomatic relief may be obtained with pitressin tannate (oily IM injection), pitressin snuff or nasal drops, synthetic lysine-8-vasopressin nasal spray, or a vasopressin analogue, desmopressin acetate, intranasally. Chlorpropamide, which is known to potentiate the action of suboptimal amounts of vasopressin, may give satisfactory result in some patients.

Vasopressin insensitive diabetes insipidus This rare disorder results from failure of the renal tubules to respond to vasopressin or to absorb water normally. It affects only males.

Manifestations, which begin soon after birth, include polyuria, polydipsia, dehydration and hyponatremia, vomiting, constipation, anorexia and failure to thrive.

Management consists in offering water at frequent intervals and giving low-sodium milk to the infant to prevent occurrence of dehydration and hyponatremia (hypernatremia in particular). Chlorothiazide and its derivatives are of value in reducing the urinary output. *Diencephalic syndrome* may present as:

- i. *Frohlich syndrome* which is characterized by obesity, short stature, hypogonadism and diabetes insipidus.
- ii. *Laurence-Moon-Biedl syndrome* which is characterized by obesity, short stature, hypogonadism, mental retardation, polydactyly and retinitis pigmentosa. It is principally a disease of males.
- iii. *Cerebral gigantism* which is characterized by very rapid growth (linear), low IQ, awkward gait, large skull, antimongoloid slant and high-arched palate.
- iv. *Albright-McCune syndrome* which is characterized by skin pigmentation, precocious puberty, advanced bone age and osseous rarefaction causing fractures.
- v. *Syndrome of generalized lipodystrophy* which is characterized by nearly absent fat (right since birth), coarse and acromegalic facies, advanced bone age, muscular hypertrophy, cardiomegaly, hepatomegaly, pigmentary changes, hypertrichosis and, eventually, diabetes mellitus.

PITUITARY AND ITS DISORDERS

Pituitary gland consists of an anterior lobe (adenohypophysis) and a posterior lobe (neurohypophysis). In between is a vestigial intermediate lobe.

The hormones produced by pituitary are:

1. *Growth hormone (GH)* Its deficiency causes pituitary dwarfism and rarely Frohlich syndrome. Gigantism results from its excess, manifesting itself before puberty. Hyperpituitarism after puberty leads to acromegaly.
2. *Prolactin* It is mainly concerned with initiation and maintenance of lactation. Its secretion is regulated by baby's "suckling" of the nipple.

3. *Gonadotrophins* Two gonadotrophins produced by pituitary are follicular stimulating hormone (FSH) and luteinizing hormone (LH).

FSH in females causes follicular growth of the ovary. Its deficiency leads to amenorrhea and excess to precocious puberty. In males, FSH stimulates gametogenesis.

LH in females causes luteinization and rupture of the follicles. Later it transforms the follicles into corpora lutea. In males, LH stimulates secretion of testosterone. Deficiency of LH causes sexual infantilism and its excess the precocious puberty.

4. *Thyroid-stimulating hormone (TSH) or thyrotrophin* It is responsible for stimulating secretion and release of thyroxine. Deficiency of TSH causes pituitary hypothyroidism and its excess the hyperthyroidism.
5. *Adrenocorticotrophin hormone (ACTH) or corticotrophin* It is responsible for stimulating secretion and release of corticoids. Its deficiency, if absolute, kills the patient in short time. Relative deficiency causes hypotension, hypoglycemia, weight loss and unconsciousness in a child who has retardation of growth and sexual infantilism. Excess of ACTH leads to Cushing syndrome.

SHORT STATURE

Refer Chapter 4 (Growth Disorders).

GROWTH HORMONE DEFICIENCY (GHD)

Etiology

It may be congenital (genetic and developmental defects) or acquired (tumors, vascular, infective, irradiation, infiltration, traumatic, autoimmune).

Clinical Features

GHD may manifest in a neonate with hypoglycemic seizures.

Short stature with normal body proportions is the cornerstone of GHD. Height age falls short of chronological age as well as bone age. Remaining features include doll-like facies, frontal bossing, depressed nasal bridge, prominent philtrum, central obesity with high subcutaneous adiposity, single central incisor, and delayed sexual development (small penis and scrotum).

Diagnosis

It is based on the following criteria:

- Height < chronologic age (< 3rd percentile)
- Bone age < chronologic age
- Growth velocity < 4 cm/year during prepubertal period
- Maximum GH after a provocative/stimulation test < 10 ng/ml
- Abnormal GH secretory pattern
- Reduced somatadin C or insulin-like growth factor-1 (IGF-1) and IGFBP-3 levels.
- Normal growth resumption following GH administration.

Differential Diagnosis

GHD-induced SS needs to be differentiated from other causes of short stature especially constitutional SS, familial SS, hypothyroidism, primary and secondary chronic malnutrition (nutritional dwarfing), Turner syndrome and GH insensitivity (Laron syndrome).

Treatment

In an established case of GHD, recombinant GH is administered in a dose of 0.07-0.1 IU/kg/day (SC) until appropriate growth is attained. Associate deficiencies of other pituitary hormones too need to be treated concurrently.

THYROID AND ITS DISORDERS

Thyroid secretes under the influence of TSH which itself is controlled by thyrotrophin-releasing hormone of hypothalamus—three physiologically active hormones. These are thyroxine, triiodothyronine and calcitonin. The so-called *feedback* mechanism also operates.

Thyroid hormones are primarily concerned in maintenance of growth, metabolism and mental development.

Thyroid deficiency results in *hypothyroidism* which may be congenital (cretinism) or acquired (juvenile hypothyroidism). Table 34.1 gives etiologic classification of hypothyroid states.

Hyperthyroidism, in the form of thyrotoxicosis, is rare in pediatric practice.

Nodule of the thyroid gland is uncommon but has 50% chance of being malignant. It is always an indication for an excision biopsy.

Table 34.1: Etiologic classification of hypothyroidism

- A. Inborn defect in synthesis of thyroxine.
 1. Defect of iodine transport.
 2. Defect in iodinating tyrosine.
 3. Defect in production, storage and release of thyroglobulin.
 4. Defect in transport of thyroxine.
 5. Defect in utilization of thyroxine.
- B. Thyroid tissue deficiency.
 1. Congenital absence.
 2. Congenital hypoplasia.
 3. Destruction from thyroiditis, surgery, or irradiation.
 4. Antithyroid antibodies.
- C. Antithyroid medication during pregnancy.
- D. Iodine deficiency (Endemic cretinism).
- E. Pituitary disease causing destruction of TSH.
- F. Hypothalamic disease causing destruction of thyroid-release hormone (TRH)

CONGENITAL HYPOTHYROIDISM (*Cretinism*)

Etiology

The most common type of hypothyroid state seen in pediatric practice throughout the world is due to absence of thyroid gland (*athyrotic cretinism*), rudimentary thyroid or dysgenesis of thyroid. It is also referred to as *sporadic cretinism*.

Clinical Features

The *earliest manifestations* include lethargy, sluggishness, hoarse cry, feeding difficulties, oversleeping, persistent constipation, prolongation of physiologic jaundice, abdominal distention with umbilical hernia, anemia (poorly responding to hematinics) and cold, dry, rough and thick skin. These infants are unusually large and heavy at birth.

The *classical features* of cretinism take a few weeks (8 to 12) to manifest (Figs 34.1 to 34.4). The facies are characteristic—a large tongue* protruding from large open mouth with thick lips, “puffy eyelids”, depressed nasal bridge, seemingly widely-apart eyes (*pseudohypertelorism*) and wrinkled forehead with sparse eyebrows and the hairline reaching to exceedingly low level over it.

The neck is short and there is often a pad of supraclavicular fat. The scalp hair is scanty, rough, dry and

* Other causes of macroglossia include physiologic, mucopolysaccharidosis, amyloidosis, glycogen-storage disease, Beckwith syndrome, congenital arteriovenous fistula, local lymphangioma or rhabdomyoma, and angioneurotic edema

4



Fig. 34.1: Profile of a cretin, aged 6 years, from an endemic area. Note mental retardation, coarse, ugly features and infantile body proportions



Fig. 34.3: Congenital hypothyroidism. Note the characteristic facial features



Fig. 34.2: Cretinism, showing characteristic features. The child's mother had been on antithyroid drugs for thyrotoxicosis during pregnancy



Fig. 34.4: Cretinism. Note the facial features, especially the large myxomatous tongue

brittle. The skin is rough, thick, dry and cold. Anterior fontanel and coronal sutures are often widely open. Voice is hoarse. Dentition is delayed. Hypotonia is more or less always present.

Rarely, hypertonia with muscular hypertrophy (Figs 34.5 and 34.6) may occur as in *Kocher-Debre-Semelaigne (KDS) syndrome*. Abdomen is often distended and an umbilical hernia of variable size is present. Hands are broad with short fingers. Anemia is generally present. Constipation, not responding to courses of laxatives, and changes in feeding regimens, is usual.

Besides the classical features, which should always arouse suspicion of cretinism, these children are very sluggish in their behavior. Mental retardation is invariably coexisting. Physical milestones are also considerably delayed. Growth is remarkably retarded. The upper segment/lower segment body ratio may continue to be 1.7:1, the so-called *infantile skeletal proportions*.

Diagnostic Investigations

These include:

- A. X-ray studies for bone age and presence of *epiphyseal dysgenesis*. The latter is seen as numerous fragmented foci of ossification, mostly in the head of femur (Fig. 34.7) and, at times, in the head of humerus. See also Chapter 3 for various ossification centres present at birth.
- B. Blood sugar (both fasting and postprandial).
- C. *Serum cholesterol* is usually elevated, especially in children beyond the age of 2 years. Here it is important to mention that normal blood cholesterol levels in infancy and early childhood are far less than the adult figures (neonates 50 to 100 mg/dl, infants 100 to 125 mg/dl, 1 to 5 years 150 to 200 mg/dl).
- D. *Serum alkaline phosphatase* is low.
- E. *Serum carotene* is raised.
- F. *ECG* is often of low voltage.
- G. *BMR* is low but neither very practical nor quite helpful.
- H. *PBI* (protein-bound iodine) is usually below 2 μg and is again not of dependable value.
- I. *Radioactive iodine* (I^{131}) is usually reduced.
- J. *Plasma TSH* (thyroid stimulating hormone) levels are high.



Fig. 34.5: *Kocher-Debre-Semelaigne (KDS) syndrome*. Note the muscular hypertrophy in a 4-year-old child



Fig. 34.6: *KDS syndrome*. Note the remarkable hypertrophy of calf muscles

- K. T_3 and T_4 levels are always decreased. Today, this is considered the most reliable diagnostic investigation for cretinism.



Fig. 34.7: Cretinism. Note the epiphyseal dysgenesis of the head of femur. Epiphyseal margin is irregular and fluffy. Substance is fragmented

Differential Diagnosis

Most of the clinical features of cretinism are also seen, individually or in certain combinations, in some other conditions.

Differences between cretinism and *mongolism* (*Down syndrome*) have already been tabulated in Chapter 23.

Pituitary dwarfism, though stressed in the old textbooks as a frequent differential diagnosis, rarely causes any difficulty in pediatric practice. A pituitary dwarf is proportionally stunted in stature but is mentally fairly sound and does not have the characteristic facial and other features of cretinism.

The most common type of mucopolysaccharidosis, *gargoylism* (*Hurler syndrome*), has mental and growth retardation as also grotesque-like rough facial and other features resembling cretinism. But, the presence of "corneal cloudiness", deformities of spine, hepatosplenomegaly and certain investigative findings in this condition are helpful in differentiating the two.

Treatment

The *replacement therapy* with thyroid must be started as soon as possible after diagnosis, if mental retardation is to be checked. Ideally, it should begin soon after birth. Hence, the vital importance of recognizing the condition in the first weeks of life.

The drug of choice at present is synthetic levothyroxine (Eltroxin). Its dose is 5 to 10 $\mu\text{g}/\text{kg}/\text{day}$ in case of patients beyond one year of age and 10 to 15 $\mu\text{g}/\text{kg}/\text{day}$ in case of neonates and infants.

Triiodothyronine is generally not recommended in treatment of cretinism. Its use is restricted to myxedema cases. Some workers, however, claim that, if used in the initial stage of therapy, its rapidity of action may be of advantage. Its 100 μg is equivalent to 60 mg of desiccated thyroid.

Adequacy of replacement therapy is indicated by return of activity, control of constipation, the skin becoming warm, correction of feeding problem, improvement in appetite and improvement in PBI or T_3 and T_4 levels.

Overdosage is indicated by diarrhea, restlessness, excitability, sleeplessness, pain abdomen, vomiting polyuria, tremors and iatrogenic hyperthyroidism. Prolonged over-treatment may cause craniosyn-

4 L. Antithyroid antibodies against thyroid peroxidase and thyroglobulin.

Neonatal screening for hypothyroidism consists in identifying neonates with low T_4 levels and high TSH by immunoassay methods employing cord blood on a filter paper. This observation is confirmed on a recall T_4 and TSH assay, thereby establishing the diagnosis of primary hypothyroidism. In case T_4 level is low and TSH also turns out to be low, the infant is further investigated for thyroid-binding capacity, globulin deficiency or secondary hypothyroidism.

In the absence of adequate screening facilities, *hypothyroid index* may be of help in congenital hypothyroidism in newborns and early infancy (Table 34.2). An index of over 4 should arouse suspicion.

Table 34.2: Hypothyroid index

Clinical features	Scores
Feeding difficulty	1
Dry skin	1
Hypotonia	1
Open posterior fontanel (more than 0.5 cm in diameter)	1
Constipation (one stool or less/day)	1
Large tongue	3
Inactivity	3
Skin mottling	3
Edematous face	3
Umbilical hernia (more than 0.5 cm in diameter)	3

Note: A score of over 4 should arouse suspicion of hypothyroidism

toxicosis. In such a situation, the dose should be readjusted. As far as possible, any interruptions in treatment should be avoided.

Replacement therapy needs to be continued throughout life.

Prognosis

“No replacement therapy” decidedly means gross mental as well as physical retardation and risks of death from superadded infections.

If adequate replacement therapy is initiated in the first 6 months of life, outlook for physical growth is fairly gratifying. About 50% of such cretins can also accomplish an IQ of 90 or even more.

ACQUIRED HYPOTHYROIDISM

Late-onset hypothyroidism, resulting from varied causes (Table 34.1) is characterized by growth retardation (at times, short stature may be the only presenting feature) with absence of gross mental retardation, stocky appearance with large head, increased upper/lower segment ratio, myxedematous skin with cold intolerance, myopathy (hypertrophy with hypotonia), pseudotumor cerebri, delayed dentition, delayed puberty, goiter, and poor school performance. Rarely, precocious puberty or hypertonia with muscular hypertrophy may be encountered. Skeletal maturation is delayed. Diagnosis and treatment are on similar lines as in congenital hypothyroidism.

HYPERTHYROIDISM (*Juvenile Graves Disease*)

Etiology

This rare disorder of excessive secretion of thyroid hormone, though rare in pediatric practice, may occur in fetal life, in neonates with history of maternal thyrotoxicosis. Usually, subjects are preadolescent or adolescents, with predominance of girls. Familial occurrence is on record.

Clinical Features

Manifestations include hyperexcitability, excessive irritability, motor hyperactivity, emotional disturbances, weight loss despite voracious appetite, palpitations, unusually tall stature and exophthalmos. Progressive cardiomegaly and cardiac insufficiency may incapacitate the patient.

Transient neonatal thyrotoxicosis may occur following transplacental transfer of maternal thyroid-stimulating immunoglobulin.

Diagnosis

Investigations include radiologic examination for bone age which is usually advanced for age, high serum T_4 and free T_4 and T_3 and free T_3 , over-suppressed TSH, and increased uptake of radioactive iodine.

Treatment

Recommended antithyroid measures are propylthiouracil (PTU), methimazole, neomercazole (carbimazole), radioactive iodine, and surgery (subtotal or total thyroidectomy).

GOITER (*Thyromegaly*)

Goiter, an enlargement of thyroid gland (lateral lobe of the thyroid gland larger than terminal phalanx of child's thumb), results from high production of TSH. It is generally secondary to low levels of thyroid hormone in the blood stream. It may be *congenital* or *acquired*. Both sporadic and endemic forms are known.

Endemic goiter is due to poor intake of iodine in water and food and is common in Himalayan mountains. *Sporadic goiter* results from failure to organify iodide. It is usually associated with congenital deafness, the so-called *Pendred syndrome*. The disorder has autosomal recessive transmission.

Congenital goiter may result from ingestion of goitrogenous (antithyroid) agents during pregnancy, or in association with cretinism due to inborn errors of thyroxine synthesis.

An outstanding example of acquired goiter is *Hashimoto thyroiditis* (autoimmune thyroiditis, lymphocytic thyroiditis). It is said to be the most common cause of childhood goiter in nonendemic areas. It is more often seen in girls and may, at times, be familial. Some patients with this goiter may progress to hypothyroid state. Treatment, if any, is thyroxine. Iodine therapy is more or less contraindicated.

Also see Chapters 11 and Chapter 15 for iodine deficiency and staging of thyroid size by palpation, respectively.

PARATHYROID AND ITS DISORDERS

These glands produce a hormone called *parathormone* which is responsible for maintenance of calcium meta-

bolism. It mobilizes calcium and phosphorus from bone. Secondly, it reduces serum phosphate by inhibiting renal tubular reabsorption of phosphate. Thirdly, it boosts reabsorption of calcium. Fourthly, it increases reabsorption of calcium from bones. Fifthly, it increases absorption of calcium from gut.

Hypoparathyroidism may result from congenital absence (aplasia) of parathyroids. When in association with aplasia of thymus, congenital defects of CNS, CVS and eye, it is termed *DiGeorge syndrome*.

Transient hypoparathyroidism may occur in newborns with hypocalcemia as a result of intake of milk of high phosphate/calcium ratio, low birth-weight infants, babies of diabetic mothers and babies born to mothers with functioning adenoma of parathyroids. The baby with transient hypoparathyroidism may have latent or overt tetany and even convulsions. Serum calcium is low.

Autoimmune hypoparathyroidism is usually seen in association with Addison disease, pernicious anemia, lymphocytic thyroiditis, persistent moniliasis, alopecia areata and steatorrhea.

Pseudohypoparathyroidism is, on the contrary, an error of end-organ response. Parathyroid secretion is good enough. These patients are mentally retarded and have poor bone growth with short fingers and toes.

Hyperparathyroidism is a very uncommon disorder. It is characterized by hypercalcemia, hypophosphatemia and hypercalciuria. Extensive demineralization of bones is evident in X-rays. Another important cause of hypercalcemia is vitamin D intoxication.

ADRENAL AND ITS DISORDERS

Adrenal cortex secretes over 30 hormonal substances, the steroid compounds. Their main functions are: (a) maintenance of electrolyte balance, (b) maintenance of carbohydrate and protein metabolism, (c) maintenance of growth and development, and (d) stimulation of sexual development.

Adrenal medulla secretes catecholamines—the adrenaline and noradrenaline. Adrenaline raises systolic blood pressure. Noradrenaline increases both systolic and diastolic blood pressures. Secondly, adrenaline increases both heart rate and output whereas noradrenaline affects heart rate alone. Thirdly, adrenaline reduces coronary flow and peripheral resistance whereas noradrenaline does the reverse.

Adrenal insufficiency may result from: (a) suppression of the gland activity from prolonged administration of steroids in such disorders as rheumatic carditis, nephrotic syndrome or idiopathic thrombocytopenic purpura, (b) adrenal hemorrhage, (c) adrenal necrosis in fulminant infections like septicemia or meningococemia (*Waterhouse-Friderichsen syndrome*), and (d) chronic failure of the adrenals—*Addison disease*—from tuberculosis or as an autoimmune process. Addison disease is rare in pediatric practice. Pigmentation of skin (Fig. 34.8) and buccal mucosa, hypotension, hypoglycemia, anorexia and weakness are its important presenting features. Diagnosis is by ACTH stimulation test. The disease responds to low doses of glucocorticoids.

Adrenal hyperactivity (hyperadrenocorticism) causes: (a) Cushing syndrome in case of cortisol-secreting lesions, (b) adrenogenital syndrome from androgen-producing lesions such as adrenal tumors or adrenal hyperplasia, and rarely (c) hyperaldosteronism.

Adrenal medullary disorders include a rare adrenaline-secreting tumor, *pheochromocytoma*, a relatively common malignant tumor, *neuroblastoma*, and a benign growth, *ganglioneuroma*.



Fig 34.8: Classical pigmentation of chronic idiopathic adrenocortical insufficiency (Addison's disease)

GONADS AND THEIR DEFICIENCY

Gonads, testes in males and ovaries in females, are no less important.

Testicular hypofunction or deficiency (hypogonadism) is an important finding in the *Klinefelter syndrome*. Such a patient has XXY chromosomal pattern with positive buccal smear, looks more of a male, is tall and may have gynecomastia. Testes are just rudimentary.

Hypogonadism in males may also result from mumps, tuberculosis, syphilis, tumors, surgical removal and lack of interstitial-cell stimulating hormone (ICSH) of the pituitary gland.

In females, an important cause of ovarian dysfunction is *Turner syndrome* (gonadal dysgenesis). Its chromosomal pattern is XO with negative buccal smear though occasionally XO/XX pattern with negative buccal smear may also be encountered. Delayed or even absent secondary sex characters, short stature, webbing of neck, cubitus valgus and mental retardation are its important clinical features. Coarctation of aorta is present in some cases. A newborn with edema, right at birth, should arouse suspicion of Turner syndrome. The patient is always a girl.

In *Noonan syndrome*, some of the features of true Turner syndrome are present but chromosomal pattern is normal.

UNDESCENDED TESTES (*Cryptorchidism*)

In some 3 to 4% of term and 20 to 30% of preterm infants, testes may fail to descend to their normal abode, i.e. scrotum, due to testicular failure, deficient hormonal stimulation, mechanical obstruction or an ectopic attachment. It may be unilateral or bilateral, the former being more common.

At times, because of the cremasteric reflex, testis may be temporarily pulled up from the scrotum into the inguinal canal or abdomen, especially when examination is conducted in a cold environment. Such a testis can be coaxed back into the scrotum by sliding the fingers from the internal inguinal ring towards the neck of the scrotum. Ascent into the abdomen can be prevented by placing the fingers across the upper portion of the inguinal canal. This condition is termed *retractile testis* or *pseudocryptorchidism*.

True cryptorchidism is characterized by undescended testis that is located in the abdomen or inguinal canal. Rare sites of location are perineum,

femoral area and front of symphysis pubis at the base of penis (*ectopic testis*).

In true cryptorchidism, scrotum on the affected side is usually smaller. An associated inguinal hernia is frequent. In bilateral cryptorchidism, scrotum is flat.

An undescended testis is vulnerable to malignancy and poor spermatogenesis.

Since spontaneous descent in cryptorchidism is unusual after the age of 1 year, the best time for therapy is between 1 to 2 years of age. If trial of hormonal therapy with human chorionic gonadotrophin (hCG) or leuteinizing hormone-releasing hormone (LHRH) fails, surgery, (orchiopexy) should be undertaken promptly by 2 years of age.

PRECOCIOUS PUBERTY

Development of secondary sex characters, much before the anticipated age, is referred to as *precocious puberty*. In tropical areas, the age landmark for boys is 9 and for girls 8 years.

Breast enlargement (Fig. 34.9), menarche, excessive enlargement of penis or clitoris, dark and coarse axillary and pubic hair, change in voice and acne rank among the various features which, if noticed in a child under 8 to 10 years, should arouse suspicion.



Fig. 34.9: Precocious puberty, showing, noteworthy breast enlargement, in a 7-year-old girl

Types

True precocious puberty or central precocious puberty (CPP) is characterized by premature occurrence of spermatogenesis or ovulation. The cause is premature activation of hypothalamic-pituitary axis, leading to secretion of gonadotrophin and complete maturation of gonads. In most cases, it is difficult to trace the exact etiologic factor operating at the level of the hypothalamic-pituitary axis (*idiopathic or constitutional type*). In some, it may be possible to find an operating factor like a congenital anomaly, post-meningitic or postencephalitic scar, tumor or previous trauma (*secondary type*).

Pseudoprecocious puberty or peripheral precocious puberty (PPP) is characterized by premature appearance of secondary sex characters and rapid somatic growth. This results from increased levels of androgenic and estrogenic hormones. The cause is at the level of adrenals or gonads.

Combined central and peripheral precocious puberty comprises existence of PPP which activates the hypothalamic-pituitary axis, resulting in CPP as well.

Diagnosis

A good history and physical examination should be of value in forming provisional impression as to the type of precocious puberty and the possible cause(s) in a particular case. A CNS tumor or a tumor of the testes, ovaries or adrenals should be borne in mind if the well-known causes do not seem to be operating.

1. X-ray studies of the skull, hands and elbows for intracranial tumors and bone age.
2. Endocrinal studies in the form of: (a) urinary 17-ketosteroids, (b) urinary pregnanediol, (c) vaginal smear for estrogen activity, and (d) gonadotrophin follicular stimulating hormone (FSH) and luteinizing hormone (LH).
3. Gonadal biopsy.
4. Surgical exploration of abdomen.

Treatment

As far as possible, the etiologic factor should be removed.

In CPP, drug therapy is in the form of gonadotropin releasing hormone (GnRH) analogues (tritrelin, leuprolide) intramuscularly once a month.

In PPP, drug therapy consists in giving progestational agents such as *medroxyprogesterone acetate*, 100 mg/m² every 2-3 week (intramuscularly) or 10 mg twice daily (O). These agents act by suppressing gonadotrophin secretion in either sex. A relatively new drug, *cyproterone*, has an additional property. It is also antiandrogenic. Excellent results have been reported by its use in a dose of 75-100 mg/m² in 2-3 divided doses. Yet another effective agent in PPP is ketoconazole.

Precocious puberty—in girls in particular—is accompanied by interlinked social and psychologic problems. The role of counseling and sex education is vital. The subjects should be advised to behave according to their chronologic age rather than their sexual age. Further, they should be protected from adverse environmental influences. Further, they need to be protected against sexual abuse.

DELAYED PUBERTY

The terms refers to the absence of signs of sexual development (increase in volume of testes in boys, breast budding in girls) by 13 years in girls and by 14 years in boys.

Etiology

Table 34.3 lists important causes of delayed puberty.

Table 34.3: Etiologic factors in delayed puberty

Constitutional delay of growth and puberty (CDGP)

Chronic systemic disorders: Chronic/prolonged malnutrition, celiac disease, tropical sprue, cystic fibrosis, chronic anemia, anorexia nervosa

Hypogonadotrophic hypogonadism (failure of GnRh and/or low FSH, LH)

Congenital/genetic: Kallmann syndrome, Prader-Willi syndrome, Laurence-Moon-Biedl syndrome, Laurence syndrome, congenital anomalies, primary gonadotrophin deficiency (hypopituitarism)

Acquired: Intracranial tumors, inflammatory lesions and traumatic lesions, irradiation of hypothalamic-pituitary region, hypothyroidism, hyperprolactinemia

Hypergonadotrophic hypogonadism/primary gonadal failure (high FSH, LH)

Congenital/genetic: Turner syndrome (45XO), Klinefelter syndrome (47XXY), Noonan syndrome

Acquired: Mumps-related orchitis, anticancer therapy for gonads, vanishing testes syndrome, testosterone biosynthetic defects, infiltrative or autoimmune diseases of gonads

Diagnosis

History and clinical examination should obtain information on primary or secondary nutritional deficiencies, chronic illnesses and any family history of delayed puberty, testicular size, phallic length, pubic hair, breast development, growth velocity, etc.

Special investigations include bone age, endocrinal assessment with special reference to basal levels of sex hormones, gonadotrophins, adrenal androgens, prolactin, GnRH stimulation and hCG stimulation tests, karyotyping, testicular biopsy in boys and pelvic ultrasonography and vaginal smear in girls.

Management

It is of the underlying cause. Hormonal therapy may be warranted to promote puberty and sustain sexual characteristics.

THE CHILD WITH AMBIGUOUS GENITALIA

It is by no means infrequent to encounter a child with ambiguous external genitalia. These are characteristic of neither a male nor a female. Hence the designation *intersex* or *hermaphrodite**.

Types of Hermaphroditism

- A. *True hermaphroditism* This condition is quite rare. Here the individual possesses both an ovary and testis, either in the same (ovotestis) or opposite gonads. Most of the subjects have 46 XX karyotype.
- B. *Pseudohermaphroditism* Here the gonads are normal. The external genitalia are, however, of the opposite sex. The condition is relatively common.

Two types of pseudohermaphroditism are "male" and "female".

Male pseudohermaphroditism (MPH) is generally characterized by male phenotype. Testes may be undescended. The penis is small (Fig. 34.10) with hypospadias. Labioscrotal folds are fused. A casual look gives an impression of female genitalia.

Female pseudohermaphroditism (FPH), the commonest variety, is characterized by female phenotype. Ovaries are present. Clitoris is large enough and looks like a penis. It is usually secondary to excessive intake



Fig. 34.10: Micropenis

of androgens by the mother or congenital adrenal hyperplasia (CAH). Box 34.1 lists the important features of CAH.

Diagnosis

Clinical

When to suspect hermaphroditism? Firstly, any male child who has a small penis, hypospadias and undescended testis deserves a check-up. Secondly, any girl with a suspicious mass in the labia majora or groin needs to be examined to ascertain if the mass could be testis.

In the history, one should trace history of fetal wastages and early neonatal deaths, the presence of intersex siblings or such other close relatives and the mode of inheritance. A history of consanguinity is of vital importance. Also, had the mother been ingesting hormones (progesterone or testosterone) during pregnancy? What was the time sequence of secondary sex characters in the child with ambiguous sex problem?

Clinical examination should confirm the presence or absence of testis (in the scrotum or inguinal canal), the degree of labioscrotal fusion, size of penis or clitoris, hypospadias and uterus through rectal examination. Renal as well as anal and other congenital anomalies should also be searched for. It is advisable to do a rectal examination for the presence of vaginal pouch, uterus or prostate.

Radiologic

- A. *Plain X-ray* for bone age which is advanced in congenital adrenal hyperplasia (CAH) but delayed in gonadal dysgenesis and hypopituitarism

* Hermes refers to the "god" and the aphrodite to the "goddess"

Box: 34.1: Important features of congenital adrenal hyperplasia

Definition: A group of inherited defects of synthesis of adrenal steroids, resulting from deficiency of one of the enzymes essential for production of steroids.

Clinical Features: *CAH due to 21-hydroxylase deficiency* Most important feature is virilization (Fig. 34.11) due to exposure to oversecreted adrenal androgens at the critical period of sex differentiation during fetal life. It may manifest as salt-losing form of CAH with severe vomiting and shock (vascular collapse), a life-threatening emergency. This is because of accompanying aldosterone deficiency. Late-onset 21-hydroxylase deficiency CAH may manifest with menstrual irregularities, hirsutism and acneis later in life.

CAH due to 11-beta-hydroxylase deficiency Most important feature of this variety too is virilization. Because of accumulation of deoxycortisol (DOC), hypertension develops sooner or later.

Rarer types of CAH include over 7 variants due to blocks at other levels.

Prenatal Diagnosis By assay of 17-ketosteroids, pregnanetriol and 17-OHP in amniotic fluid, by genotyping or HLA typing of amniotic cells obtained by chorionic villus sampling.

Neonatal Screening By 17-OHP assay in blood from heelprick.

Treatment

Prenatal Dexamethasone at 5th gestational week and later.

Postnatal Glucocorticoids, increased salt intake, surgical correction.



Fig. 34.11: Congenital adrenal hyperplasia. Note the ambiguous genitalia

- B. *Retrograde genitourethrogram* for status of urogenital sinus and other internal genital structures.
- C. *Noninvasive imaging* (ultrasonography, CT scan, MRI) for status of internal genitalia, undescended gonads and anomalies of adrenal glands.

Laboratory

- A. *Buccal smear/peripheral blood or bone marrow karyotyping* It is a mirror of the real gonadal sex rather than the external sex. In true hermaphrodites

and female pseudohermaphrodites, nuclear sex chromatin is positive. A negative buccal smear occurs in male hermaphrodites.

- B. *17-Ketosteroids and pregnanetriol* Urinary excretion of these substances is increased in androgen-induced pseudohermaphroditism, the so-called *congenital adrenal hyperplasia*.
- C. *Serum electrolytes* These may be of value in identifying salt-losing variety of congenital adrenal hyperplasia. High serum potassium in a child with ambiguous external genitalia, positive buccal smear, and advanced bone age (especially when there is high excretion of 17-ketosteroids and pregnanetriol in urine) nearly confirm this diagnosis. It is an emergency.
- D. *Chromosomal studies* Only in an occasional case such an analysis may be needed. Its indication will only be when buccal smear suggests some abnormality.
- E. *Urethroscopy, vaginogram, IVP* These may be of help in difficult cases to identify vagina, uterus and anomalies of the urinary tract.
- F. *Gonadal biopsy* Bilateral gonadal biopsy is a "must" when gonads are in the abdomen. In vague situations, a biopsy may be of value even though these are present externally.
- G. *Laparotomy* This may be necessary in many instances to be certain of the diagnosis.

Treatment

Early diagnosis and rearing of the child accordingly are vital. Administration of corticosteroids (hydrocortisone 20-25 mg/m²/24 hours, prednisolone 0.5 mg/kg/24 hours, in 2 divided doses) and early correction of external genitalia (feminizing genitoplasty in first year, vaginoplasty, if needed at adolescence or later) give gratifying results in congenital adrenal hyperplasia (CAH). During infection/surgery, dose of steroids should be increased 2-3 fold. In salt-losing CAH, 4-8 g of sodium chloride should be given in first 24 hours in case of development of dehydration, preferably with 9-alpha-fluorocortisone acetate (0.05-0.1 mg/day).

DIABETES MELLITUS

Childhood diabetes, also referred to as *juvenile* or *growth-onset diabetes*, is characterized by wide-range of metabolic abnormalities of carbohydrates, proteins

and fats in the body. Today, it is the commonest endocrine-cum-metabolic disorder of childhood and adolescence with far-reaching effects on child's physical and emotional development.

It is estimated that childhood diabetes accounts for around 5% of total population of diabetics. In India alone, there are likely to be about 4,00,000 infants and children with this disease. A WHO report places the figures at 40,000 in Bangladesh, 60,000 in Pakistan, 20,000 in Sri Lanka, 27,000 in Nepal and 5,000 in Afghanistan.

Childhood Diabetes vs Adult Diabetes

The differences between the two are given in Box 34.2.

Box 34.2: Childhood diabetes vs. adult diabetes

1. Childhood diabetes is usually rapid in onset, often first presenting as diabetic coma. Onset in case of adult diabetes is insidious.
2. Unlike adult diabetes, obesity plays no role in childhood diabetes.
3. Children always need injectable insulin. Most adults with diabetes respond to oral hypoglycemic agents.
4. Dietetic control alone never works in diabetic children.

Current Classification

Diabetes mellitus is now classified globally as Type I and Type II (Box 34.3).

The major differences between the two types are summarized in Table 34.4.

Etiologic Considerations

Almost 95% of pediatric cases belong to the *idiopathic* category—absolute deficiency of insulin—believed to be a hereditary inborn error of metabolism. In a considerable proportion of cases, the disease runs in the family. Siblings—identical twins in particular—show higher incidence than the parents.

In a much smaller category, the disease is secondary to such causes as Cushing syndrome, hyperpituitarism and surgical removal of the pancreas.

Transient diabetes of the newborn is more or less a benign condition. It disappears in 4 to 8 weeks period.

That genetic factors play role in type I diabetes stands established (Table 34.5). This explains why the disease has higher incidence in some families, the concordance rates in monozygotic twins and ethnic and racial differences in prevalence. It is now believed

Box 34.3: World Health Organization (WHO)/American Diabetes Association (ADA) classification of diabetes mellitus

Type I diabetes (juvenile-onset diabetes) is characterized by gross insulinopenia and dependence on exogenous insulin for prevention of ketoacidosis. It occurs predominantly in childhood but no age is a bar. Association with certain autoimmune processes and diseases is its outstanding feature.

Type II diabetes (previously termed adult-onset diabetes, maturity-onset diabetes or stable diabetes), is usually not insulin-dependent and not complicated by ketoacidosis. It is rare in children and adolescents. Notably, there is no association with autoimmune process or disease.

Other specific types (secondary diabetes mellitus)

- Genetic defects of beta-cell function: Mitochondrial DNA
- Genetic defects in insulin action: Leprechaunism
- Diseases of exocrine pancreas: Cystic fibrosis, pancreatitis, fibrocalculous pancreatopathy, surgery
- Endocrinopathies: Cushing syndrome, hyperthyroidism, acromegaly
- Drug/chemical induced: Steroids, diphenylhydantoin, thiazides, diazoxide, pentamidine
- Infections: Rubella virus, CMV
- Immune-mediation: Stiffman syndrome, anti-insulin receptor antibodies
- Other genetic syndromes: Down syndrome, Turner syndrome, Klinefelter syndrome, Laurence-Moon-Biedl syndrome, Wolfram syndrome

Table 34.4: Major differences between type I and type II diabetes

Features	Type I	Type II
Mode of onset	Acute	Slow
Age of onset (years)	< 30, predominantly childhood	> 30
Family history of diabetes	Around 10%	Strong
Concordance in identical twins	25-50%	100%
Role of obesity	No proven role	A remarkable predisposing factor
Association with HLA-DR 3 and 4	2.5 times	Strong
Anti-islet cell antibody	> 80%	< 5%
Ketoacidosis	Common	Negligible
Microvascular complications	Rare	Frequently present
Insulin	A must for treatment	Infrequently needed

that at least one major vulnerable locus may reside in the DQB₁ gene. Around 100 fold relative risk for developing type I diabetes is conferred by the homozygous absence of aspartic acid at position 57 of the HLA-DQB chain (nonAsp/nonAsp).

Table 34.5: Disorders associated with diabetes

Diseases	Genetic syndromes
Cystic fibrosis	
Hashimoto thyroiditis	Prader-Willi syndrome
Adrenal insufficiency	Werner syndrome
Atrophic gastritis	Cockayne syndrome
Vitamin B ₁₂ malabsorption	
Multiple endocrine deficiency syndrome	
Acanthosis nigricans	

Autoimmune basis for development of type I diabetes in predisposed individuals has a wide support by now. The increased prevalence of the disease in individuals with Hashimoto thyroiditis, Addison disease and pernicious anemia (all resulting from an autoimmune mechanism) as also presence of islet cell antibodies (ICA) in 80 to 90% patients of diabetes strongly favors the auto-immune basis. The type I diabetes as well as the aforesaid disorders are known to be associated with an increased incidence of certain HLAs that are located on chromosome 6 and are a cluster of genes. The latter code transplantation antigen, plays a major role in immune response.

In addition, certain triggering factors like mumps, rubella, coxsackievirus and, perhaps, some other viral infections play some role in inducing type I diabetes. Antecedent stress and some toxins are also implicated as triggering factors. The triggering factors may act by destroying the B cells, by persisting in cells as a slow damaging factor, or by inducing a widespread immune response.

How does insulin lack produce multiple metabolic abnormalities? Since sugar cannot enter cells, the latter utilize amino acids or fatty acids as alternate energy sources. What follows is fat and energy (protein) wasting. Acetone, acetoacetic acid and beta-hydroxybutyric acid tend to accumulate in the circulation.

Clinical Features

The onset is generally acute. Excessive thirst (*polydipsia*), polyuria (more marked at night, the so-called *nocturia*), enuresis in a child who was earlier dry, excessive hunger (*polyphagia*), weight loss, general weakness, tiredness and bodily pains are the earliest presenting features. "Fainting attacks" due to spontaneous hypo-glycemia, vulvitis, pain abdomen,

nausea and vomiting, irritability and deterioration in school performance may also occur.

Diabetic coma may well be the first manifestation forcing the parents to bring the child to the hospital.

Diabetic ketoacidosis in early stage manifests by symptoms of hyperglycemia and ketoacidosis, including polyurea, polydipsia, polyphagia, nocturia, loss of weight, nausea, vomiting, abdominal pain (at times simulating pancreatitis or appendicitis), backache, and dehydration. In advanced disease, change in sensorium, increased respiratory rate with Kussamaul breathing (rapid deep breathing in an attempt to excrete excess CO₂) preceded by one or more precipitating factor (infection, trauma, inter-current illness) are present. Untreated ketoacidosis invariably ends up in coma.

Diagnosis

Once pointers in the clinical profile have aroused suspicion, the diagnosis must be confirmed by certain investigations:

1. *Urine examination* for sugar and acetone. Urine sugar may be detected by Benedict test or by employing the specially prepared strips* which give the result within a minute and are highly reliable.

For detecting acetone in urine, ferric chloride and Rothera tests or paper strips** may be employed.
2. *Fasting blood sugar* above 126 mg/dl is suggestive, between 100-126 mg/dl is highly probable (suspicious) and above 160 mg/dl is diagnostic of diabetes mellitus. *Casual (random) blood sugar* above 200 mg/dl on two separate occasions in a clinically suspected situation strongly supports the diagnosis.
3. *Glucose tolerance test*, though infrequently required, should be performed in doubtful cases, with a glucose dose of 1.75 g/kg ideal BW (maximum 75 g).

Diabetic ketoacidosis (DKA) is characterized by hyperglycemia (glucose over 250-300 mg/dl), ketonemia, acidosis (pH under 7.3 and bicarbonate under 15-20 mEq/L), glucosuria and ketonuria. It needs to be distinguished from acidosis and/or coma from other causes, say hypoglycemia, uremia, severe

* Diastix (Miles India Ltd)

** Ketodiastix (Miles India Ltd)

dehydration with metabolic acidosis, encephalitis, salicylism, etc.

Nonketotic hyperosmolar coma exists when there is profound hyperglycemia (glucose over 600 mg/dl), nil or slight ketosis, nonketotic acidosis, severe dehydration, and neurologic signs like seizures, positive Babinski, hyperthermia and hemiparesis. The condition is infrequent in children.

Management

Routine Diabetes

Though diabetes can be managed at home, in order to achieve initial stabilization, the diabetic child should be hospitalized for some days. Various objectives of management include:

- Control of overt manifestations
- Safeguarding against progression to diabetic ketoacidosis (DKA)
- Safeguarding against development of hypoglycemia
- Ensuring good nutrition for normal growth and development
- Prevention/treatment of superadded emotional overlay
- Early detection and treatment of infection(s)
- Prevention of complications (acute, intermediate and chronic vascular).

Insulin in low dose regimen is the current recommendation. A daily dose of 0.5 unit/kg body weight of soluble insulin suffices in a large majority of the cases. This total dose should be divided into 2 parts, 2/3rd to be injected before breakfast, and 1/3rd before dinner. According to the *split-mix regimen*, each dose consists of 2/3rd lente (NPH) and 1/3rd regular insulin. Urine should be examined before each injection. Some patients may require increase in dose or one or two additional injections before glycosuria and ketonuria are really controlled. One must make sure that if an alteration in total dose is warranted, it is in neither over 10-15% of total dose nor over 6 units/day.

After a few days, a combination of rapidly-acting soluble insulin and delayed-acting insulin (Lente, intermediate or long acting) may be all right. It is worth noting that slight glycosuria is acceptable. In fact one should not be fussy about having too many "clear" samples of urine to minimize risk of hypoglycemia.

About 3-month insulin therapy may cause such a great deal of improvement that the patient requires no more insulin for many months. It is, however, advisable to continue about 5 units of insulin during this phase of remission. This is of value in preventing *insulin allergy* as well as resistance when the full-dose insulin therapy is resumed on relapse.

Ultralente insulins having as prolonged action as 30 hours and ability to maintain a constant blood level and a short-acting human insulin analogue are also available now.

Table 34.6 lists the important investigative components in the diabetic child already on treatment.

Table 34.6: Ideal investigative components in pediatric diabetes during follow-up

- Self-monitoring of blood glucose, urine glucose and ketones
- Glycosylated Hb every 3 months
- Urine for proteins at each follow-up visit
- Serum lipids (cholesterol, HDL, LDL, VLDL, fractions and triglycerides once a year
- Thyroid function tests (TSH, T₄)
- Ophthalmic check-up, including funduscopy, by an expert once a year

4

Diabetic Ketoacidosis (DKA)

DKA is a serious emergency. In its management, immediate concern is to restore fluid volume and acid-base status to normal rather than aim at stable euglycemia.

Two regimens of insulin therapy are available:

1. *Conservative (Intermittent)* 1 to 2 units/kg of soluble insulin is administered, half intravenously and half subcutaneously. If further administration is needed, the dose is 0.5 to 1 unit/kg after 3 to 4 hours or 1/5th of the initial dose every 1 to 2 hours.
2. *Continuous low dose infusion* This is the most modern treatment of diabetic ketoacidosis/coma. The dose of soluble insulin for this purpose is 0.1 unit/kg bolus followed by 0.1 unit/kg/hour. It is added to the delivery chamber of the infusion set. The method causes fall of blood sugar at the rate of approximately 75 mg/dl every hour. The insulin infusion is required to be continued until the blood sugar falls to 250 mg%. Following fall of blood sugar < 250 mg/dl, 5% glucose may be added to the drip to prevent rapid fall in blood sugar.
3. Rest of the treatment consists in giving:
 - *Intravenous drip* to combat dehydration and electrolyte imbalance which are often present.

Initial fluid should be isotonic saline (0.9%) and the quantity based on the assumption that dehydration in diabetic ketoacidosis is in the order of 10%. The rate should be so adjusted that only 50 to 60% of the calculated deficit is given in the first 12 hours. Rest of the 40 to 50% of the deficit therapy is given in the next 24 hours.

Potassium should be added early to the infusion (when about 20 ml/kg of isotonic saline has been given) and continued as long as drip is continued. It should be administered as potassium phosphate. If symptomatic hypocalcemia develops, it should be corrected with calcium gluconate.

Soda bicarbonate is recommended only when pH is under 7.2. For pH 7.1 to 7.2, the dose is 40 mEq/sq m; for pH under 7.1 it is 80 mEq/sq m. It should be infused over a 2-hour period. A bolus infusion may cause cardiac arrhythmias and is not recommended.

If raised intracranial pressure develops, life saving measures like reduction in rate of infusion, mannitol (10 to 20 ml/sq m IV, repeated at 2 and 4 hours) and hyperventilation must be instituted.

When blood pH has reached over 7.3 and blood glucose under 300 mg/dl, patient is usually in a position to take oral feeds. At this stage, it is appropriate to switch from IV insulin to SC insulin.

- **Monitoring** DKA management is incomplete without close monitoring of vital signs, level of sensorium and such investigations as blood glucose and urine ketone, electrolytes, pH and urine output all along the course of IV infusion.

It is advisable to have an initial ECG and repeat it 6-8 hourly. Serum calcium and phosphate should be done every 6-8 hourly and when IV infusion is terminated. A high index of vigilance and suspicion is vital to prevent/detect iatrogenic hypoglycemia (blood sugar < 60 mg/dl; early symptoms: sweating, pallor, trembling, tachycardia, late symptoms: drowsiness, confusion, seizures and coma) and cerebral edema that may complicate overcorrection with very high doses of insulin, hyperglycemia, hyperosmolality, overuse of alkali and overhydration.

- **Antibiotics** to control superadded infection
- **Diet** With the aforesaid regimen, most children with diabetic ketoacidosis can switch on to oral fluids after 8 hours and semisolids by 12 hours. The physician should see to it that the patient leads, as far as possible, a normal life and achieves normal growth and development. This necessitates intake of recommended requirements for age. Around 45-50% calories should come from carbohydrates (preferably complex carbohydrates like wholemeal cereals, wholemeal bread and pulses), 15-20% from protein and 25-30% from fats (avoid upper limit). Today, the trend is to avoid too many dietetic restrictions. Concentrated carbohydrates like candies, sugar, sweets, chocolates and cakes should, however, be avoided.
- **Parental education** The physician must discuss various aspects of child's diabetes with the child as also with parents. The exercise has got to be a continuing program. This needs a good rapport between the physician on one hand and the child and the family on the other. The child and parents need to learn administration of insulin injection, blood sugar testing, recognition of warning signals of hypoglycemia, hyperglycemia, ketoacidosis, infection, etc.

Complications

These may be acute, intermediate or chronic (Table 34.7).

Prognosis

Modern treatment has revolutionized the course of diabetes mellitus. Most children with controlled disease have fairly reasonable growth and development. There is remarkable increase in the average life span. With this increase in the life expectancy, the risk of long-term complications does coexist.

THE OBESE CHILD

Definition and Screening

Obesity is defined as the excessive accumulation of fat in the subcutaneous and other body tissues and parts. Whereas in case of *overweight*, body weight is increased over 110% of the standard weight (corresponding to >30 mm triceps skinfold thickness), in obesity the increase exceeds 120% of the standard weight.

Table 34.7: Common complications of pediatric diabetes mellitus

Acute (usually reversible) Diabetic coma, ketoacidosis, hypoglycemia, fulminant and hidden infections.

Intermediate (potentially reversible) Growth failure, delayed sexual maturation, impaired neuropsychiatric development, restricted joint mobility

Chronic (usually irreversible) Secondary to macro or microvascular pathology and manifesting later in life.

Ophthalmic Retinopathy (most frequent microvascular alteration after 2 years of age)

Neuropathy Reduced motor nerve conduction velocity, sensory changes, reduced vibration perception, peripheral neuropathy, hypoglycemic awareness due to autonomic neuropathy

Vascular Hypertension, atherosclerosis.

Renal Kimmelstiel-Wilson syndrome, renal failure, overt nephropathy (urine protein > 0.5 g/24 hours, albumin 0.3 g/24 hours or 200 µg/minute), microalbuminuria (urine albumin 0.03-0.3 mg/24 hours or 20-200 µg/minute)

Metabolic Cataract.*

Hepatic Hepatomegaly.

Chronic infections Boils, styes, abscesses, fungus infection, tuberculosis.

* Other causes of late-onset cataract include Down syndrome and myotonic dystrophy

As already pointed out in Chapter 3, the most dependable and best parameter for screening children for obesity is the *body mass index* (BMI) which is known to correlate very well with total body as well as subcutaneous fat and, at the same time, allows a variation in lean body mass. Moreover, high BMI also correlates with blood pressure and serum lipid levels. There is evidence that it has a considerable predictive value for obesity in adult life as also morbidity and mortality accompanying it.

$$\text{BMI} = \frac{\text{Weight (kg)}}{\text{Height (met)}^2} = \text{kg/met}^2$$

In terms of BMI, obesity is categorized as

Grade 1 25-29

Grade 2 30-40

Grade 3 >40

Many authorities, designate BMI 25-29 as "borderline obesity" or just "overweight".

Etiopathogenesis

Exogenous obesity (Table 34.8) as a result of excessive dietetic consumption, is today the most important

Table 34.8: Etiology of obesity

Exogenous: Constitutional, overeating (energy intake exceeding expenditure), poor energy expenditure, fat cell hyperplasia

Endogenous: *Genetic/chromosomal syndromes* Laurence-Moon-Biedl syndrome (Figs 34.12 and 34.13), Turner syndrome, Prader-Willi syndrome (Fig. 34.14)

Endocrinal Hypothyroidism, Cushing syndrome (Fig. 34.15), hypogonadotrophic hypogonadism, pseudohypoparathyroidism (Albright syndrome), polycystic ovaries (Stein-Leventhal syndrome)

Hypothalamic Frohlich syndrome, postencephalitic (Fig. 34.16), postmeningitic

Deficiency Leptin

Drug-induced Steroids, clonazepam, valproate.

nutritional problem in the European countries. But it is now beginning to hit the upper strata of society in the developing world as well. That is a paradox indeed. For a large segment of the population in these areas continues to live almost below the survival line. These obese children have to carry the load of a large body. This exhausts them easily, thereby further reducing their physical activity. This adds up to their obesity.



Fig. 34.12: Laurence-Moon-Biedl syndrome. Note the obesity, hypogonadism and short stature (height 140 cm) in this 14-year-old boy



4 **Fig. 34.13:** Laurence–Moon–Biedl syndrome, besides obesity, the child has mental retardation, polydactyly, hypogenitalism and short stature



Fig. 34.15: Cushing syndrome, showing buffalo type obesity involving primarily the upper half of the body



Fig. 34.14: Prader-Willi syndrome. Note obesity, hypotonia, hypogenitalism and mental retardation. The child had noteworthy hyperphagia



Fig. 34.16: Obesity in a 5-year-old, following encephalitis

Endogenous obesity is associated with genetic or chromosomal syndromes, endocrinal conditions, hypothalamic causes and intake of certain drugs.

Physiologic obesity occurring in early adolescence is frequent among girls in particular. It is temporary and regresses after adolescence.

Clinical Features

In order to label a child “fatty”, the weight should be above 90th percentile for that age as per the standard charts or in excess by 20% of average weight for age and BMI above 30 kg/m² or 95 percentile. Height may be normal or little more than the average.

Fat deposition is generalized with excessive deposition over the neck (*double chin*), gluteal region, thighs, abdomen and around the breasts. External genitalia, hands and feet appear rather small. *Knock-knee* deformity is often present. Occasionally, *slipped femoral epiphysis* may also be there. These children often have emotional problems. Apparently, they may seem “happy go lucky type”. But, as a matter of fact, they suffer from “loneliness” and profound psychologic trauma.

Diagnosis

Investigations include X-rays for bone age, blood sugar, cholesterol, LFTs and thyroid profile.

CT scan, MRI, genetic studies, urinary free cortisol and overnight dexamethasone suppression test are indicated in select cases in whom serious disease is on the card.

Leptin, which reduces the hypothalamic drive is indicated in leptin-deficiency obesity.

In gross obesity (weight for height > 200%), surgical intervention may be considered. At present, procedure of choice is gastric by pass.

Management

Treatment, in most instances, is dietetic restriction in the form of curtailment of intake of snacks in between main meals and drastic cut-down on intake of chocolates, candies, sweets and icecream, and greater physical activity (participation in sports and exercises, reducing TV watching). The results are not a matter of few days but of months and years. The physician must also handle the accompanying emotional overlay tactfully. Appetite-inhibiting agents, like amphetamines are best avoided.

SHORT STATURE

Endocrinal causes of short stature include hypothyroidism, hypopituitarism, congenital adrenal hyperplasia, etc. The entity is discussed in details in Chapter 4 (Growth Disorders).

FURTHER READING

Articles/Chapters

1. American Diabetic Association. Clinical practice recommendations. *Diabetes Care* 2000;22 (Suppl 1).
2. Bajpai A, Sharma J, Menon PSN. *Practical Pediatric Endocrinology*. New Delhi: Jaypee 2003.
4. Gupte S. *Differential Diagnosis in Pediatrics*, 5th edn. New Delhi: Jaypee 2007.
6. Menon PSN, Mishra NK, Muthukumar V. Precocious puberty, gelastic seizures and hypothalamic hamartoma. *Indian Pediatr* 1993;30:924-927.
7. Pandey S, Vaidya R, Shringi M. Growth hormone therapy. In Gupte S (Ed): *Recent Advances in Pediatrics (Special Vol 13: Pediatric Endocrinology)*. New Delhi: Jaypee 2004;88-108.
8. Rosner B, Prineas R, Logg J, Daniels SR. Percentiles for body mass index in US children 5-7 years of age. *J Pediatr* 1998;132:211-222.
9. Sushama Bai S. Diabetic ketoacidosis. In Gupte S (Ed): *Recent Advances in Paediatrics*, Vol. 10. New Delhi: Jaypee 2000;434-444.
10. Tank S, Chauhan PH, Ghildiyal. Obesity. In Gupte S (Ed): *Recent Advances in Pediatrics (Special Vol. 13: Pediatric Endocrinology)*. New Delhi: Jaypee 2004;108-125.

Book/Monograph

1. Gupte S. *Recent Advances in Pediatrics (Special Vol 13: Pediatric Endocrinology)*. New Delhi: Jaypee 2004.

CHAPTER



Genetics in Pediatric Practice

Suraj Gupte, S Frank

DEFINITION

The term, *genetics* (*gene* stands for “to become”), first coined by Bateson in 1906, implies the branch of biologic science that deals with the transmission of characters from parents to offsprings.

GENETICS IN HUMAN WELLBEING

Table 35.1 summarizes important applications of genetics.

Table 35.1: Important applications of genetics

- Contributes to better understanding of etiology of disease
- Contributes to appreciation of the mechanism behind the normal variations between individuals.
- Prevention of genetic disorders through prenatal diagnosis and genetic counseling.
- Treatment of certain genetic disorders through correction or replacement of the defective gene (genetic engineering).
- Resolution of medicolegal problems involving disputed parentage through determination of blood groups or other hereditary characteristics.

Molecular genetics has revolutionized the whole field of medicine with fast-increasing understanding of the heritable disorders and advances in approach to diagnosis, genetic counseling and screening of subjects at risk for genetic diseases. The field promises the treatment of the diseases through direct correction of a mutation at the DNA level. In some cases it may be possible to replace a normal or modified gene for an erratic one. The so-called *gene therapy* is now in the thick of a breakthrough.

This chapter proposes to deal with certain fundamental facts about organization of the genetic

equipment, applications of this knowledge in genetic disorders, gene therapy, and genetic counseling.

HUMAN CELL DIVISION

Development of a new human being follows fertilization of the ovum by a spermatozoa. The composition of the zygote determines the so-called “traits” of the new individual.

The somatic cell has a cytoplasm and a nucleus that consists of chromatin. Its central structure is the gene that is located on the chromosome. The principal constituent of gene is deoxyribonucleic acid (DNA) which is supposed to perform the following two functions:

- Control of various enzymes of the cell that govern the cellular metabolism
- Replication for reproduction

Cell division occurs in two forms: mitosis and meiosis.

Mitosis is the longitudinal division of each chromosome, occurring in all somatic cells in an asexual manner. The daughter cells contain the same number of chromosomes as the parent cell.

Meiosis is the sexual division and occurs during gamete-to-genesis. The homologous chromosomes are arranged in pairs. By a process of dysjunction, one member of the pair passes into each cell. After division, resulting cells (haploid) have half the number of chromosomes.

As and when division occurs, each gene produces a similar copy of itself. Nevertheless, at times, the internal organs of the gene is altered during division. This is what is termed *mutation* and the new gene the *mutant gene*.

The variations in humans, a reflection of differences at the DNA level, in the form of mutations have a definite impact on the health and functioning of a gene. There are, of course, variations that do not have any impact on the health and functioning of a gene. These are called *polymorphisms*.

The term *missense mutation* is used when in a mutation the base is changed within an exon, leading to change of a corresponding amino acid in the protein.

THE GENES

The genes are the hereditary material that code for the “characters” and are linearly arranged on the chromosomes, each occupying specific locus.

Each gene is made up of deoxyribonucleic acid (DNA) in which genetic information lies. Its fundamental configuration resembles a rope-ladder with ropes that are made up of alternating deoxyribose and phosphate molecules and each rung consisting of guanine, cystosine, adenine and thymidine. The whole structure is twisted into a *double helix* (Fig. 35.1). This sequence (“triple code”) forms the template of ribonucleic acid (RNA). The latter transfers the “message” to the ribosome in protoplasm of cell from chromosomes in the nucleus and interprets in the shape of an amino acid sequence.

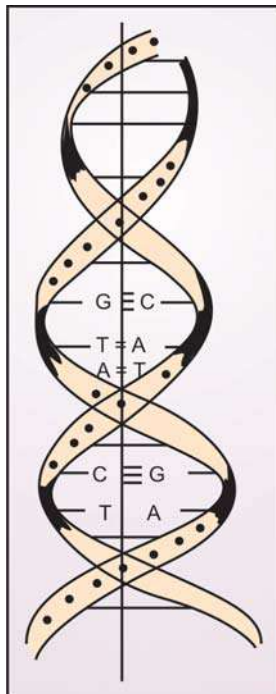

Fig. 35.1: DNA double helix

The genes are always paired. If a particular individual carries identical genes, he is said to be *homozygous*. If, on the other hand, he carries different genes, he is heterozygous.

In determining the resulting trait, one member of pair of genes may only express. This gene is termed *dominant*. The gene which fails to express is called *recessive*.

The term *phenotype* is referred to the outward appearance of an individual. The underlying genetic constitution is called *genotype*.

The term, *genome*, is used for entire human genetic program. Each human cell contains two copies of the genome amounting to 6 million base pairs (bp) of DNA.

TYPES OF INHERITANCE

A. *Autosomal dominant* A homozygous person produces heterozygous offsprings if he mates with a normal partner. If both the partners are heterozygous, the offsprings may be 3 affected (2 heterozygous, 1 homozygous) and 1 normal. If an heterozygous mates with a normal, result may be a normal or an affected offspring in a ratio of 1 : 1.

Examples Hereditary spherocytosis, achondroplasia.

B. *Autosomal recessive* Here the disease will manifest only when gene is present in homozygous state. To produce the homozygous state, two carriers have got to meet, a situation which is certainly uncommon. In the parents with affected offsprings for a recessive gene, the incidence of first-cousin marriages are the high as 40% compared to the very low figure of 0.4% in the random population.

Examples Majority of the inborn errors of metabolism, including phenylketonuria (PKU), galacto-semia, alkaptonuria, thalassemia major, Morquio disease, Hurler syndrome, retinitis pigmentosa, Laurence-Moon-Biedl syndrome, Marfan syndrome, achondroplasia and cystic fibrosis.

C. *Autosomal Co-dominant* Here, two dominant genes are said to impose upon a recessive gene. *Examples* A and B blood groups dominate over O group.

D. *X-Linked dominant* Here, affected males transmit the trait to daughters only. The heterozygous affected female transmits the trait to either sex offsprings in a 1:1 ratio. In case of a union between the affected

partners, 3 of the 4 offsprings are likely to be affected. *Examples* Vitamin D-resistant rickets (hypophosphatemia), fragile X syndrome (FMR-I).

- E. *X-Linked recessive* Here, overt disease occurs in the male and is transmitted by a carrier female. *Example* Hemophilia, nephrogenic diabetes insipidus, Hunter, syndrome, Duchenne myopathy, ocular albinism, ichthyosis.

VARIATIONS IN EXPRESSION OF GENETIC TRAITS

Certain hereditary traits may be suppressed or brought out by such factors as (a) accidental skipping of a generation and (b) environmental influences.

A person may inherit the abnormal genes. But he may only suffer from a very slight defect, not obvious to the casual observer but otherwise detectable by radiologic studies and/or by biochemical methods. This is called *reduced expressivity* of the gene.

The term, *penetrance*, applies to the percentual frequency with which a heterozygous dominant or a homozygous recessive gene manifests itself. When there is no detectable expression of abnormal genes, *skipping of a generation* is ascribed to *reduced penetrance*.

An important instance of environmental influences is hemolytic anemia manifesting in a G-6-PD deficient individual. This happens only when he is exposed to such agents as are dependent for their metabolism on this very enzyme.

TYPES OF GENETIC DISORDERS

These may be of 5 types:

1. Chromosomal disorders
2. Single gene disorder
3. Multifactorial (polygenic) disorders
4. Mitochondrial disorders
5. Somatic cell disorders (cancer-producing).

THE HUMAN GENOME PROJECT (HGP)

Launched in 1989, HGP is targeted at determining the complete nucleotide sequence of the human genome by the year 2005. This sequencing of the human genome will be of vital assistance in studying the structure and function of a gene and its mutations that cause various genetic disorders.

THE CHROMOSOMES

The chromosomes, rod-like basophilic structures made of closely coiled chromatin, are the seat of the *genes*. Like genes, these also exist in pairs.

Number

There are 22 pairs of identical chromosomes (*autosomes*) and a pair of *sex chromosomes* in each cell, the total being 46. The latter is labelled XY in males and XX in female. This number is termed *diploid number*. Nevertheless, in spermatozoa and ova, the number of chromosomes is only, 23, i.e. just half of the diploid number. This is termed *haploid number*. A female germ cell always has X chromosome. On the other hand, a male germ cell either has X or Y chromosome. Thus, if a female gamete (ovum) is fertilized by a sperm carrying X chromosome, the fertilized ovum will have a configuration XX and the child will be female. If a female gamete (ovum) is fertilized by a sperm carrying Y chromosome, the outcome will be XY configuration and, therefore, a male child (Fig. 35.2).

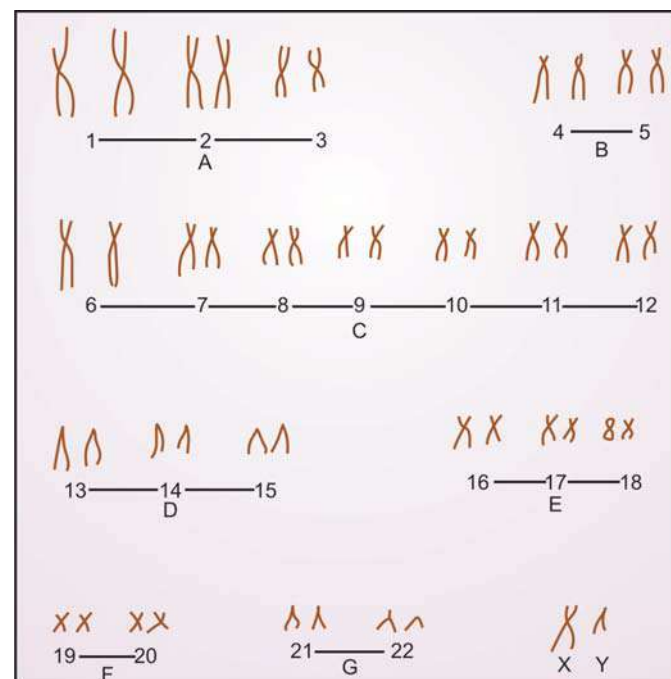

Fig. 35.2: Male karyotype. Note the XY pattern against the XX pattern in females

Size, Shape and Structure

Most chromosomes vary from 4-6 microns in length. In addition to the rod-like appearance, chromosomes may assume twisted, spiral or curved shape.

Chemical constituents of a chromosome are deoxyribonucleic acid (DNA), ribonucleic acid (RNA), histones and acidic proteins.

Each chromosome consists of two rod-shaped structures (*chromatids*) which are identical, lie parallel to each other, and are united at a constriction (primary constriction), termed *centromere*. Thus, each chromatid is divided at the centromere into two arms (Fig. 35.3).

Types

Depending on the position of the centromere in relation to the two strands called *chromatids*, each chromosome falls in one of the following types:

1. *Metacentric* when arms are equally long and centromere is central.
2. *Submetacentric* when arms are unequal and centromere is away from the center
3. *Acrocentric* when centromere is almost at the end and a satellite is present.
4. *Telecentric* when centromere is terminal and each chromatid has one arm only.

Denver Classification (Modified)

Group A: No. 1 to 3

Group B: No. 4 to 5

Group C: No. 6 to 12

Group D: No. 13 to 15

Group E: No. 16 to 18

Group F: No. 19 to 20

Group G: No. 21 to 22

Sex chromosomes: XX in female, XY in male.

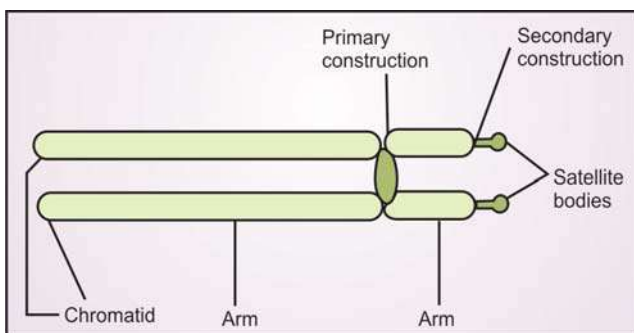

Fig. 35.3: Structure of chromosome

Sex Chromatin

The characteristic of female cells is the presence of chromatin masses in the nuclei, the so-called *barr bodies*. Skin and buccal mucosal nuclei (around 25 to 60%) are positive for such bodies (chromatin positive) in females. Identical bodies, called "drumstick", are also found in 1 to 3% polymorphs in females.

Chromosomal Studies

Chromosomal studies are indicated in the following situations:

- Confirming diagnosis in suspected chromosomal disorders such as Down syndrome, Turner syndrome, Klinefelter syndrome, etc.
- Investigations of a child with ambiguous genitalia
- Determination of sex of an unborn child
- In separation of X or Y bearing spermatozoa.
- In determining effects of environmental or occupational hazards on chromosomes.

Two major techniques are:

- Karyotyping in which complete chromosomal complement of an individual's leukocytes is studied
- Study of (i) sex chromatin or barr bodies, (ii) fluorescent bodies in buccal smear, or (iii) drumsticks in polymorphonuclear (PMN) leukocytes.

CHROMOSOMAL DISORDERS

A. *Changes in number* The chromosome number may be an exact multiple of haploid number (23) e.g. 46, 69, 92,.... The term euploid is applied to this situation. When there is a deviation from one of the euploid numbers, the situation is called *aneuploid*. When chromosome number is just more than normal, it is termed *polyploid*. In Klinefelter syndrome (XXY), there is an extra X. In Turner syndrome (XO), an X chromosome is missing. Other sex-chromosome aberrations include triple-X or superfemale, XYY male and XX male. Chances of mental retardation and skeletal defects are enhanced by extra X chromosome.

In a trisomy, there is a nondisjunction of the concerned chromosome. In Trisomy 21 (Down syndrome), the two homologues fail to go to the opposite poles of the dividing cell. Trisomy 13-15 (D), also called Patau syndrome and trisomy 16-

18 (E)-Edward syndrome—rank prominently among the various other trisomies described to date. These are, of course, rare. Occasionally, chromosomal division may result in cells with different number of chromosomes. This is called *mosaicism*.

B. *Deletion* There may occur deletion of the short arm of chromosome 5 (*Cri-du-chat* or *catcry syndrome*), short arm of chromosome 19, or long arm of chromosome 21 or 22 (*antimongolism*). Deletion of the long arm of chromosome 22 with the translocation of the deleted segment on to chromosome 9 is associated with chronic myeloid leukemia.

C. *Translocation* Two types are recognized: reciprocal and centric fusion or Robertsonian translocation.

The former means exchange of segments between two homologous chromosomes. The latter involves acrocentric chromosomes in which the breaks occur close to the centromeres of recipient and donor chromosomes.

D. *Ring chromosome* When both tips of chromosomes are broken and ends of centric fragment rejoin forming a chromosome with a deletion of both arms, the chromosomes are called ring chromosomes.

E. *Inversion* This term is applied when segment between two chromosomes breaks, a single chromosome is inverted, and order of the genes is reversed. Inversion may be pericentric or paracentric.

Table 35.2 provides salient features of leading chromosomal disorders.

4

Table 35.2: Salient features of leading chromosomal disorders

Syndromes	Chromosomal aberration	Incidence	Manifestations
Down syndrome	Trisomy 21 Translocation Mosaicism	1 in 600-800 births	See Chapter 23
Patau syndrome	Trisomy 13	1 in 20,000 births	Cleft lip, polydactyly and flexed fingers, hemangiomas, broad, flat nose, low-set malformed ears, microcephaly, microphthalmia, hypoplastic or absent ribs, genital and visceral anomalies, including cardiac and cerebral
Edward syndrome	Trisomy 18	1 in 8,000 births	LBW, closed fists, narrow hips with poor abduction, rocker-bottom feet, microcephaly, microphthalmia, cardiac and renal anomalies, mental retardation; 95% mortality in infancy
Mosaicism	Trisomy 8	Not known	Long face with high forehead, broad upturned nose, thick everted lower lip, low-set ears, high-arched/cleft palate, microretrognathia, osteoarticular anomalies, moderate mental retardation
Turner syndrome cardiovascular	Loss (total or a part) of sex chromosome Pattern: 45, XO	1 in 8,000 livebirths	Short stature, peripheral edema, lymphadema, extra skin fold/webbing of neck (Fig. 35.4), renal and anomalies, gonadal dysplasia, some learning disability, absence of sex characters, infertility, treatment with estrogens
Klinefelter syndrome	An extra X chromosome Pattern: 47, XXY Variants with more than X chromosomes may occur	1.3 in 1,000 livebirths; 80 in 1,000 in mentally retarded; 100-200 in 1,000 in infertile males	Relatively tall stature, gynecomastia, slow development of secondary sex characters, azoospermia, small testes, infertility, psychosocial, behavior maladjustment, mental retardation; treatment replacement therapy with testosterone
XYY males minor	Additional Y chromosome(s)	1 in 1,000 livebirths	Relatively tall stature, behavioral problems, infrequently genital anomalies, radioulnar dysostosis and prolonged PR interval
Fragile X syndrome	Fragile site at Xq 27,3 of distal long arm of chromosome X; due to change in size of DNA sequence (allelic expansion)	Commonest cause of mental retardation in males	Mental retardation, long face with prominent jaw and large ears, macroorchidism



Fig. 35.4: Turner syndrome. Note the classical webbing of the neck

INBORN ERRORS OF METABOLISM (IEM)

Ever since Garrod described in early part of the 20th century four inherited metabolic disorders, there has been continued addition to the list. Today, hundreds of disorders, mostly rare and autosomal recessive, are recognized. The number is, no doubt on constant increase. An interesting feature of such disorders is that they usually have their clinical manifestations in almost all systems.

IEMs are the consequence of mutations in the DNA which code for a specific protein that acts as an enzyme, receptor, transport vehicle, membrane pump or structural element.

Absence of a single enzyme leading to disturbance of that particular metabolic pathway (accumulation of compounds proximal to the enzymatic block or deficiency of product distal to it) is the underlying causative factor in a large majority of the cases.

A large majority of IEM manifest soon after birth while others present later with unexplained manifestations (Table 35.3).

Table 35.4 presents a comprehensive list of ever increasing number of inborn errors of metabolism according to the type of metabolism affected. Many of these defects are dealt with elsewhere in this volume. Some of the genetic disorders of special clinical importance in pediatrics are tackled briefly and yet comprehensively in this very chapter.

Table 35.3: Situations in which inborn errors of metabolism (IEM) should be suspected

Newborns

Unexplained lethargy, vomiting, icterus, feeding problem, vomiting, seizures, coma, tachypnea, odd body odor, hypoglycemia, acidosis, hyperammonemia, high blood or urine levels of metabolites (say amino acid or ammonia).

Infants and Children

- Unexplained mental and/or developmental delay, motor deficit or seizure
- Unexplained hepatomegaly as such or with splenomegaly
- Unexplained odd odor, especially during an acute illness
- Corneal opacity, cataract or dislocation of lens
- Unexplained kidney stone
- Unexplained episodic vomiting, acidosis and coma.

Table 35.4: Classification of inborn errors of metabolism

Amino Acid Metabolism

Phenylketonuria (PKU), tyrosinosis, albinism, alkaptonuria, cystinosis (including deToni-Fanconi syndrome), cystinuria, homocystinuria, Hartnup disease, maple syrup disease, lysine intolerance.

Carbohydrate Metabolism

Congenital lactose intolerance, galactosemia, glycogen storage disease (glycogenosis), diabetes mellitus, scurvy, gargylism. Morquio disease.

Lipid Metabolism

Abetalipoproteinemia, progressive lipodystrophy, lipidosis (Gaucher disease, Neimann-Pick disease. Tay-Sachs disease, hyperlipo-proteinemia).

Protein Metabolism

Immunoglobulin deficiencies, absent clotting factors (hemophilia, Christmas disease, afibrogenemia, hypoprothrombinemia), metal-binding protein deficiency (Wilson hepatolenticular degeneration), alpha-1-antitrypsin deficiency (neonatal hepatitis).

Pigment Metabolism

Porphyrias, methemoglobinemia, albinism, Waardenburg syndrome, Crigler-Najjar disease, Dubin-Johnson disease, Gilbert disease, Rotor syndrome, primary hemochromatosis.

Unknown Biochemical Defect

Osteogenesis imperfecta, Marfan syndrome, achondroplasia, Ehlers-Danlos syndrome.

PHENYLKETONURIA (PKU)

This is a rare hereditary autosomal recessive defect due to deficiency of enzyme, *phenylalanine hydroxylase* (or simply *phenylalaninase*). This enzyme is responsible for converting phenylalanine to tyrosine. At least four types are known.

Clinical Features

The child with classic PKU is usually blonde and blue-eyed due to absence of the pigment, *melanin*. He looks normal at birth. Before long, however, he begins to have vomiting, irritability, anorexia, excessive sweating which gives a peculiar odor, and eczema. Convulsions, mental retardation with hyperactive personality and erratic behavior may become obvious as the child grows.

Diagnosis

It is confirmed by demonstrating serum phenylalanine level exceeding 20 mg/dl (1.2 mM) and by ferric chloride test or *Phenistix* paper strips showing excess of phenylalanine and its metabolites in the urine. A neonatal screening program for PKU is now available in several countries.

Treatment

A low phenylalanine diet must begin before the baby is 2 weeks old, maintaining the serum phenylalanine at about 8 mg/dl, if mental retardation is to be prevented.

ALBINISM

This group of IEM is the result of defective melanin production because of defect in the oxidative enzyme, *tyrosinase*. Oculocutaneous albinism has 10 types and is usually inherited as an autosomal recessive trait. Ocular albinism four types and is inherited as an X-linked or autosomal recessive. Partial albinism is inherited as an autosomal dominant trait.

ALKAPTONURIA

This rare autosomal recessive disorder, the very first IEM described by Garrod in 1908, is the result of aberrant tyrosine metabolism and accumulation of homogentistic acid in body and urine because of deficiency of the enzyme, *homogentistic acid oxidase*.

Manifestations include discolored urine (dark brown-black), pigmentation of face, nose, ears and eyes (ochronosis), and degenerative arthritis.

Diagnosis is from a positive Benedict's test and Ferric chloride test which gives purple-black color on a urine sample.

No specific therapy is available for this benign condition.

HOMOCYSTINURIA

This autosomal recessive disorder results from high concentration of homocystine and its dietary precursor (methionine) in blood and other body fluids because of deficiency of enzyme, *cystathionine beta-synthetase*.

Manifestations, usually beginning after infancy, include mental retardation, skeletal abnormalities (scoliosis, pectus excavatum, arachnodactyly), thromboembolism and ocular abnormalities (ectopia lentis, myopia, cataract, strabismus, keratitis, iris atrophy, spherophakia, uveitis, pupillary block, glaucoma, retinal detachment, optic atrophy).

Diagnosis is by demonstration of high levels of methionine and homocystine in body fluids and/or assay of the enzyme in liver biopsy. Prenatal diagnosis is available.

This treatable IEM responds favorably to dietary restrictions of methionine plus vitamin B₆ (pyridoxine).

MAPLE SYRUP URINE DISEASE (MSUD)

This condition results from failure of decarboxylation of branched chain amino acids (leucine, isoleucine and valine) because of deficiency of the enzyme, *branched chain ketoacid dehydrogenase*.

Manifestations of the classical MSUD start in neonatal period and include poor feeding, seizures, hypertonicity, lethargy, refractory hypoglycemia, metabolic acidosis and coma. Body fluids, especially sweat and urine, have a characteristic odor of maple syrup. Hence, the name.

Diagnosis is confirmed by demonstrating high levels of branched chain amino acids in urine and blood.

Treatment is diet low in branched chain amino acids (say, a special synthetic formula) and thiamine. In acute exacerbation, excess of the offending amino acids needs to be removed from circulation by peritoneal dialysis with IV administration of high energy nutrition.

Prognosis is guarded. Untreated neonates die within weeks.

HARTNUP DISEASE

In this rare autosomal recessive disorder, a defective transport of tryptophan in the gut and renal tubules leads to deficiency of nicotinic acid.

Manifestations, simulating pellagra, include photosensitive dermatosis, psychiatric symptoms, headache, ataxia, diplopia and tremors. Such factors as sulfa drug therapy, infection, undernutrition and stress are known to precipitate the symptoms.

Diagnosis is by demonstration of large amounts of indoles and indicans in urine.

Treatment is administration of nicotinic acid, 50-300 mg/day, plus protection from exposure to sunshine.

TYROSINEMIA

Tyrosinemia type I, an autosomal recessive trait, results from raised serum tyrosine level because of deficiency of enzyme, *fumarylacetoacetate hydrolase*. The neonatal or acute form manifests in first 6 months whereas the latent or chronic form manifests after first year of life. Manifestations common to both forms include FTT, developmental delay, cabbage-like odor and hepatic failure. The chronic form may additionally have renal tubular dysfunction, vitamin D resistant rickets and polyneuropathy.

Diagnosis is from estimation of specific enzyme activity in liver biopsy or cultured fibroblasts.

Tyrosinemia type II (oculocutaneous tyrosinemia), a rare autosomal recessive disorder, results from deficiency of enzyme, *tyrosine transaminase*. Manifestations include mental retardation, hyperkeratosis of palms and soles, corneal ulcers, etc. Liver and kidneys are spared.

Treatment of tyrosinemia consists of a diet low in tyrosine, phenylalanine and methionine (only in type I). Type I may eventually need liver transplantation.

Transient tyrosinemia of the newborn, resulting from delayed maturation of enzyme, *p-hydroxyphenyl pyruvic acid oxidase*, is usually a self-limiting condition occurring predominantly in preterm neonates on high protein formula. Manifestations in symptomatic cases include feeding difficulty, lethargy and poor motor activity. Reduction in intake of protein plus vitamin C help to correct the aberrant state.

GALACTOSEMIA

This again is a rare autosomal recessive defect, due to absence of the enzyme, *galactose-1-phosphate-uridylyl-transferase* which is responsible for converting galactose to glucose. With the missing of the said enzyme, galactose accumulates in the blood and tissues.

Besides this classical form, two additional forms of galactosemia are galactokinase deficiency and uridyl diphosphogalactose-4 epimerase deficiency.

Clinical Features

The child starts manifesting the disease as soon as milk—the main source of galactose—is given to him. He has feeding difficulties, vomits and fails to thrive. Jaundice and hypoglycemic convulsions may occur in the neonatal period. Hepatomegaly starts quite early though development of splenomegaly may take some time. Pseudotumor cerebri occurs in some cases.

If the treatment is delayed and the patient survives, cataracts* and gross mental retardation follow in due course of time. Damage to the kidneys may cause albuminuria and aminoaciduria.

Diagnosis

Investigations demonstrate galactosemia, hypoglycemia, and galactosuria. Erythrocytes show increased level of galactose-1-phosphate.

Treatment

It consists in absolute withdrawal of milk and its products from the diet. After several years, the child may be able to tolerate galactose-containing foods.

To prevent mental retardation and cataract, progesterone has been found to be of value.

GLYCOGEN STORAGE DISEASE (GSD)

At least a dozen types of glycogen storage disease are known, each resulting from deficiency of one or the other enzyme in the synthesis or breakdown of glycogen. All are rare and usually acquired as autosomal recessive conditions.

GSD type I or von Gierke disease is the most common and is due to deficiency of enzyme *glucose-6-phosphatase*. Clinical features include doll face, stunted growth, hepatomegaly (usually massive) (Fig. 35.5), ketonuria, hyperuricemia, bleeding tendency and hypoglycemic convulsions. Diagnosis is confirmed by liver biopsy which shows increased fat and glycogen and absence of glucose-6-phosphatase. Gout may complicate the

* Other causes of early-onset cataract include Hurler syndrome, Lowe syndrome, gangliosidosis and low birthweight



Fig. 35.5: Glycogen storage disease. Note the massive hepatosplenomegaly

4

clinical picture after puberty. Treatment is frequent feeding. Soda bicarbonate may be given to prevent acidosis.

GSD type 0, due to deficiency of enzyme, *glycogen synthetase*, is characterized by severe hypoglycemic seizures in infancy.

GSD type IIa or *Pompe disease* is characterized by progressive cardiomegaly and CCF.

GSD type IIb is characterized by muscular dystrophy without involvement of the heart.

GSD type III or *Con disease* is characterized by involvement of liver, striated muscles and red cells. Clinical features mimic those seen in Type 1.

The remaining types are more or less of only academic interest.

Treatment in the GSD type I (which is amenable to therapy) is frequent day time feeds and night time glucose IV infusion to ensure normoglycemia. Some subjects may require allopurinol for safeguarding against uric acid nephropathy.

GAUCHER DISEASE

It is a kind of lipidosis and is inherited as an autosomal recessive condition. The cause is deficiency of the enzyme, *beta-glucosidase*, in brain, liver, spleen, bone marrow and other organs.

The *infantile type* is characterized by rapidly progressive visceral enlargement and mental retardation.

The *juvenile type* is rapid in development of hepatosplenomegaly. Brain, however, remains unaffected.

The adult type, on the contrary, is slow in progression. It is characterized by anemia, thrombocytopenia and involvement of the long bones.

Diagnosis of Gaucher disease is by demonstration of typical cells (Gaucher cells) in the bone marrow or splenic puncture.

Treatment is symptomatic. Infantile form has the worst prognosis and progressive neurologic involvement. Death is more or less a rule.

NIEMANN-PICK DISEASE

This is another rare disease, a lipidosis inherited as an autosomal recessive character, in which an enzyme, *sphingomyelinase*, is absent. This results in accumulation of sphingomyelin in various tissues and organs.

The disease is characterized by mental retardation, hepatosplenomegaly, lymphadenopathy, weight loss and abdominal distention. A *cherry-red spot* may be seen in every third patient of this disease, in the region of macula. Anemia, usually moderate, is invariably present. Death generally occurs in infancy.

Diagnosis is by demonstration of *Niemann-Pick cells* in blood, marrow or splenic puncture. Miliary tuberculosis-like picture may be seen in the X-ray of the chest. No effective treatment is available.

MUCOPOLYSACCHARIDOSIS (MPS)

The term, *mucopolysaccharidosis*, refers to a group of hereditary conditions accompanied by storage of acid mucopolysaccharides in the tissues. The characteristic of the group include:

- In each of the disorders, a special enzyme deficiency is known to occur.
- Skeletal deformities (*dysostosis multiplex*) are universal for mucopolysaccharidosis.
- Involvement of the CNS with progressive mental retardation is common.
- Multiple organs/systems including CVS, liver, spleen, skin, joints and tendons may be affected.
- All have autosomal, recessive mode of inheritance, the only exception being Hunter syndrome which follows an X-linked recessive trait.

- Each type is suspected clinically and the diagnosis confirmed by demonstration of increased urinary excretion of the specific mucopolysaccharide products and the specific enzyme deficiency (Table 35.5).
- No definite treatment is as yet available for any of these disorders. The value of steroids remains doubtful.

Table 35.5: Salient features of various mucopolysaccharidoses (MPS)

MPS types	Enzyme defects	Urinary mucopolysaccharides	Clinical manifestations	Radiology
Hurler syndrome (MPS IH)	α -L-Iduronodase	Dermatan sulfate Heparansulfate	Grotesque facies, cloudy corneas, mental retardation, dwarfism, hepatosplenomegaly, kyphosis (Figs 35.6A and B) umbilical hernia	Large dolichocephalic skull and thickened calvarium, boot or J-shaped sella turcica, thickening of medial third of clavicle, lower dorsal and upper lumbar vertebral bodies ovoid with beak-like projections anteriorly, spatulated ribs, flaring of iliac bones, shallow acetabula, coxa valga, tapering of terminal phalanges and proximal metacarpal ends, widening of distal metacarpal ends, articular surfaces of radius and ulna form a "V", angulation of humerus
Schei syndrome (MPS)	α -L-Iduronodase	Dermatan sulfate	Coarse facies with cloudy corneas, prognathism, joint stiffness (esp claw hands), carpal-tunnel syndrome, aortic regurgitation, normal IQ	Mild dysostosis multiplex without vertebral changes; coxa valga, "V" deformity of radius and ulna articular surfaces
Hurler-Schei syndrome (MPS IH/IS)	α -L-Iduronodase	Dermatan sulfate	Coarse facies with corneal cloudiness, joint stiffness/contractures, dwarfism, hepatosplenomegaly, hernias, mitral regurgitation, mental retardation	Same as Hurler syndrome minus gibbus
Hunter syndrome (MPS 11)	Iduronosulfate sulfatase	Dermatan sulfate Heparan sulfate	Type A: Coarse facies, hepatosplenomegaly, short stature, joint stiffness, hernias, severe mental retardation, deafness; corneal cloudiness rare; mild gibbus in some; skin changes and cardiac involvement frequent. Type B: Much milder than type A with nil or minimal mental and physical retardation	Same as in Hurler syndrome minus gibbus
Sanfillipo syndrome (MPS III)				Same as in Hurler syndrome with only mild involvement of long bones
A	Sulfamidase	Heparan sulfate	Delayed milestones, hyperactivity in first decade;	
B	α -N-Acetylhexoglucosaminidase	Heparan sulfate	later neurologic signs with ataxia, mental retardation;	
C	Acetyl CoA: α -glucosaminidase N-acetyltransferase	Heparan sulfate	joint stiffness, hepatosplenomegaly, hernias; skeletal deformities;	
D	N-Acetylglucosamine-6-sulfatase (specific for heparan sulfate only)	Heparan sulfate	dwarfism and corneal cloudiness rare	

Contd...

Contd...

MPS types	Enzyme defects	Urinary mucopolysaccharides	Clinical manifestations	Radiology
Morquio syndrome (MPS IV)				
A	N-Acetylgalactosamine-6-sulfate sulfatase and galactose-6-sulfatase	Keratan sulfate Chondroitin sulfate	Short stature, gross skeletal defects with short neck, spine and limbs; semi-crouching stance from kyphoscoliotic spine, barrel chest and prominent abdomen; facies are characteristic with permanent grin and corneal cloudiness; hepatosplenomegaly, no mental retardation (Fig. 35.7)	1st year: only loss of height and tongue like projections anteriorly of vertebral bodies, 3rd year: platyspondyly, mild involvement of skull and sella turcica, shortened long bones with irregular metaphyses, wide acetabula with subluxation of femoral head, short and wide metacarpal bones with conical tapering of proximal ends, "V" sign of radius and ulna
B	b-Galactosidase	Keratan sulfate		
Maroteaux-Lamy syndrome (MPS VI)	N-Acetylgalactosamine-4-sulfate (arylsulfatase B)	Dermatan sulfate	Coarse facies, macrocephaly, short neck and trunk, pectus carinatum, claw hands, joint contractures, umbilical hernia, hepatosplenomegaly, abdominal distention, corneal opacities, mitral/ aortic regurgitation; normal IQ	Same as in Hurler syndrome
β -Glucuronidase deficiency syndrome (MPS VII)	β -Glucuronidase	Chondroitin 4/6 sulfate	Hepatosplenomegaly, umbilical hernia, thoracolumbar gibbus, mental retardation.	Same as in Hurler syndrome
Keratan and heparan sulfaturia (MPS VIII)	N-Acetylglucosamine-6-sulfate sulfatase (specific for keratan sulfate and heparan sulfate)	Keratan sulfate Heparan sulfate	Developmental retardation, scaphocephaly, pectus excavatum, blindness.	Same as in Morquio syndrome minus platyspondyly.

4



Figs 35.6A and B: Hurler syndrome, showing grotesque facies with large protruding tongue, mental retardation, hepatosplenomegaly and bony deformities



Fig. 35.7: *Morquio syndrome.* Note widespread skeletal deformities (these included short neck, short trunk, spinal curvature, barrel-shaped chest, knock knees), and characteristic facies with prominent maxillae, short nose and broad mouth (widely spaced teeth are not apparent here). The subject had hepatosplenomegaly and was mentally normal

PRENATAL DIAGNOSIS

Situations for Which Prenatal Diagnosis is Available

Table 35.6 gives the list of various situations for which prenatal diagnosis is currently available.

Indications

Table 35.7 gives the categories of mothers that should be offered the benefit of antenatal diagnosis. It also indicates the risk of severe fetal abnormalities in each situation.

Techniques

- *Chorionic villus sample (CVS):* Here the needle is inserted into the chorionic bed by transabdominal or transcervical approach and 5-40 mg of chorionic sample is obtained.
- *Amniocentesis:* 10-20 ml of amniotic fluid is obtained by transvaginal route (early pregnancy, 12-14 weeks) or transabdominal route (late pregnancy,

Table 35.6: Situations for which prenatal diagnosis is at present available

<i>Chromosomal Disorders</i>	Down syndrome. Rh Incompatibility.
<i>Genetic/Metabolic Disorders</i>	Duchenne muscular dystrophy, glycogen storage disease, Gaucher disease, familial idiocy, hemophilia, thalassemia, etc.
<i>Anatomic Defects</i>	Anencephaly, meningomyelocele, etc.

Table 35.7: Mothers needing prenatal diagnosis

Category of mothers	Risk of fetal defect
1. 35 years and older	2.6%
2. With history of a previous mongol baby	1.0%
3. With history of one or more babies affected by a neural tube defect	5 to 10%
4. With history of a previous baby affected by a diagnosable autosomal recessive metabolic disorder	25%
5. Recognized carriers of a severe X-linked recessive disorder	25%
6. With abnormally high serum AFP levels found during routine antenatal screening	Up to 75%
7. Liable to have chromosomally imbalanced baby because of partial chromosome translocation or mosaicism	20%

16 weeks) under continuous ultrasonography view and examined for cytogenetics and AFP (Fig. 35.8).

- *Cord blood sample (cordocentesis):* It consists in inserting a needle through maternal abdomen along the sonographic plain and then advancing it into the umbilical vein. On a small blood sample, CBC, blood gas analysis and karyotyping can be done.
- *Ultrasonography:* It has emerged as an important tool for screening the fetus for developmental defects and chromosomal anomalies.
- *Maternal blood AFP:* Raised levels are seen in neural tube defects, fetal death, ventral wall defect, congenital nephrosis and oligohydramnios and reduced levels in Down syndrome and aneuploidy
- *Fetal tissue biopsy (Skin, muscle, liver):* It is indicated when DNA diagnosis is unclear or impracticable.
- *Preimplantation biopsy:* It is indicated in X-linked recessive disorders like alpha-1-antitrypsin deficiency and cystic fibrosis.
- *Fetal cells in maternal circulation:* These can be separated and analyzed to identify chromosomal anomalies.

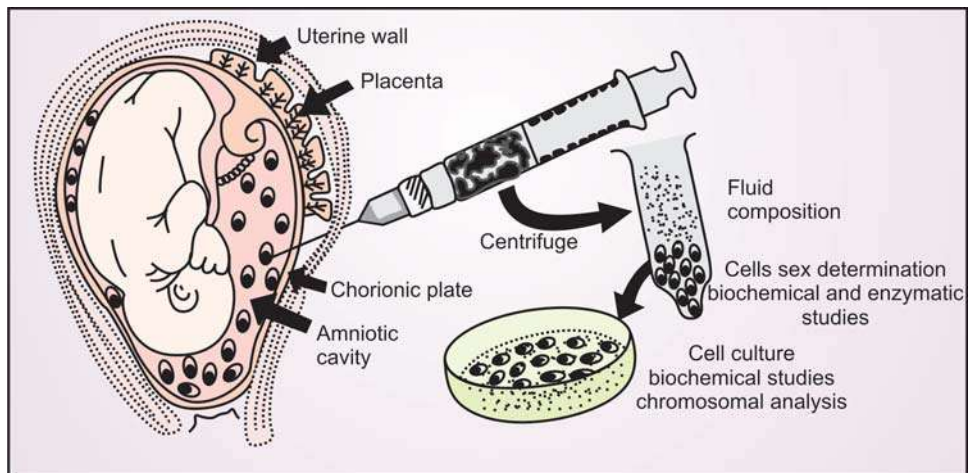

Fig. 35.8: The technique and uses of amniocentesis as per the Institute for Research in Reproduction, Mumbai

4 DERMATOGLYPHICS

This term is derived from the Greek words, *derma* meaning skin, and *glyphi* meaning curve. Dermatoglyphics, therefore, refer to the study of ridge and flexion patterns in handprints, soleprints and fingerprints.

Normally, fingerprints show 3 ridge patterns: arch, loop and whorl. The ulnar loops are maximum on digit 3 and 4 though they are dominant in all the digits. In digit 1 and 4, whorl pattern is maximum. Radial pattern is dominantly seen on digit 2. Arches are far less with maximum frequency in digit 2 and 4. The point where the three ridge systems meet is best seen at the base of the fingers on the palm. These points are termed triradii. The triradius lying close to the Wrist is called axial triradius.

Likewise, the three basic patterns of the palmar creases are the usual palmar crease, the single palmar crease and Sydney line. The last two are called simian creases (Fig. 35.9).

It is now established that these ridges develop between the second and the fourth months of embryogenesis. In case of abnormal embryogenesis during this period, abnormalities of dermatoglyphic patterns may result. In other words, presence of abnormal dermatoglyphic patterns reflects some developmental insult, such as chromosomal disease, during the second to fourth months of gestation.

In Down syndrome, trisomies 13 and 18 and certain X-linked disorders, characteristic dermatoglyphic patterns have been described.

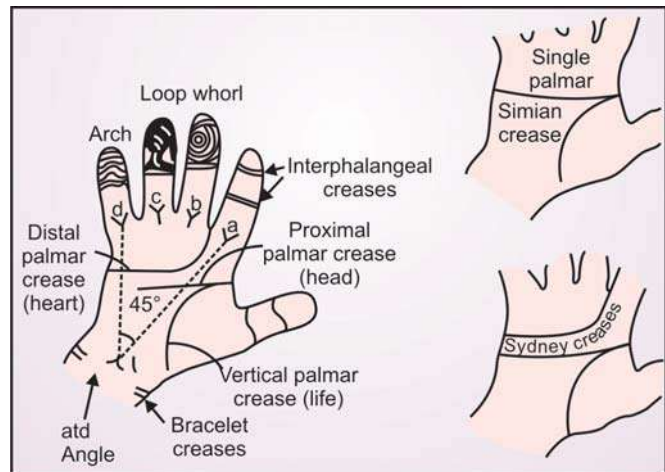

Fig. 35.9: Dermatoglyphic patterns

It is of value to measure the angle subtended between the axial triradius at the triradii at the base of the index and little fingers. It is called atd angle. In normal individuals it measures around 45 (< 57) degree but it may be as much as 90 degree in Down syndrome and 110 degree in trisomies 13-15.

There is a strong association between Simian crease on one hand and Down syndrome and leukemia on the other hand. It is expected to be present in 50% of cases of Down syndrome and in high proportion of autosomal trisomies.

The total ridge count in Klinefelter syndrome is considerably reduced as compared to the normal of 128 to 145. In female, it is zero. It seems that the count is inversely proportional to the number of sex chromosomes an individual possesses. The ridge count in Turner syndrome is as high as 178.

Dermatoglyphics in acute rheumatic fever show that position of axial *triradius* is abnormal with ulnar deviation (tu) with or without distal displacement (t''u or T''u) resulting in abnormal atd angle.

Abnormal dermatoglyphics have also been reported in such conditions as Indian childhood cirrhosis, congenital heart disease and protein-energy malnutrition.

GENE THERAPY

Close on the heels of identification of genetic alterations leading to diseases, advances are in progress to alter the pathologic disease processes by employing genes. Following successful gene therapy in adenosine deaminase (ADA) deficiency, scores of gene transfer experiments on humans are being actively pursued (Table 35.8).

The process of introducing a therapeutic gene into the target cells is termed *gene transfer*. The cells containing the newly transferred gene are called "transduced" with the particular gene. Gene transfer is carried out either by "transfection" or "infection". Transfection means the direct delivery of DNA to cells. The transfer through infection involves a virus vector. Retroviruses are the vector of choice for most gene therapy protocols. Adenoviruses and liposomes are also being employed for this purpose.

Table 35.8: Some of the remarkable gene therapy trials

Disorder	Gene inserted	Target Cells
• ADA deficiency	Adenosine deaminase	Lymphocytes
• AIDS kinase	HSV thymidine	CD+T-cells
• Neuroblastoma	IL-2	Tumor cells
• Cystic fibrosis of pancreas	CFTR	Airway epithelium pancreas
• Hemophilia A and B	Factor VIII and IX	Fibroblasts
• Beta-hemoglobinopathies	Beta globin	Blood formed elements
• Familial hypercholesterolemia	LDL receptor	Liver, smooth muscle cells, epithelium of blood vessels
• PKU	Phenylalanine hydroxylase	Liver
• Gaucher disease	Acid beta-glucosidase, glucocerebrosidase	Macrophages, liver, lung, spleen
• Alpha 1-antitrypsin deficiency	Alpha 1-antitrypsin	Lungs, liver

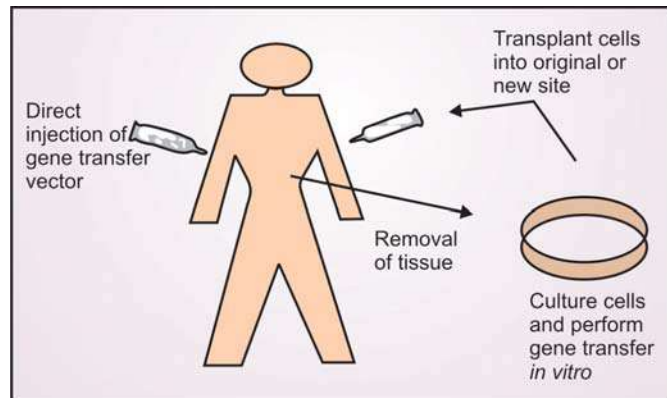

Fig. 35.10: *In vivo* versus *ex vivo* gene therapy. *In vivo* gene therapy involves direct delivery of the gene transfer vector to the patient. In contrast, *ex vivo* gene therapy involves removal of tissue from the target organ, delivery of the gene transfer vector to cultured cells, and transplantation of the modified cells back into the patient

Two procedures of gene therapy are (1) *in vivo*, and (2) *ex vivo* (Fig. 35.10). The *in vivo* therapy involves direct delivery of the gene transfer vector to the patient. The *ex vivo* therapy involves removal of target cells from the target organ, introduction of therapeutic genes into these cells and then infusion of the cells back to the patient.

A central prerequisite for gene therapy is that the disorder must be a single gene disorder of recessive inheritance, and DNA sequence for the gene should be available for purpose of transfer.

All said and done, it must be appreciated that gene transfer may be accompanied by major adverse effects on the patient, including transfer of a potentially dangerous infection. This snag and other difficulties in the way of positive outcome of gene therapy are likely to be overcome in the near future.

With further advances in successful genetic engineering, quite a few ethical, social and policy issues may also need to be ironed out.

GENETIC COUNSELING

The term *genetic counseling*, denotes informing the individuals or families about the present and future possible genetic disorder(s) and the various options available for safeguarding from recurrence of such a disorder or minimizing its adverse effects.

Before talking to the family in which a child is diagnosed as suffering from a genetic disorder, the pediatri-

cian must ensure that the following prerequisites are satisfied:

- Construction of an accurate pedigree chart
- Documentation of prenatal, antenatal and delivery history
- Review of the available information about the disorder
- Detailed clinical check-up of the affected child, including the photographs and measurements
- Confirmation of the diagnosis by the relevant tests
- Preparedness with information regarding support groups for the benefit of the family
- Preparedness with the ongoing information about the disorder, and new modalities for its management for conveying it to the family.

The components of the counseling session should include:

- Exact or round about diagnosis; when that is not possible, differential diagnosis
- Natural history of the disorder with prognosis and potential therapy, as also referral to a better center/ institution

- Genetic aspects and recurrence risk of the disorder
- Prenatal diagnosis and prevention, e.g. ultrasonography for neural tube defects, amniocentesis/chorionic villus sampling for chromosomal abnormalities, biochemical disorders and DNA studies
- Support groups
- Follow-up in which benefits of new information about the concerned genetic disorder should be provided to the child/parents.

FURTHER READING

Articles/Chapters

1. Kulkarni ML, Vangalath S. Gene therapy. In Gupte S (Ed): *Recent Advances in Pediatrics-7*. New Delhi: Jaypee 1997:321.
2. Kulkarni ML, Vangalath S. Human genome project. In Gupte S (Ed): *Recent Advances in Pediatrics-7*. New Delhi: Jaypee 1997:294.

Books/ Monographs

1. Scriver CH. *The Metabolic and Molecular Basis of Inherited Disease*, (8th edn). McGraw Hill: New York 2000.
2. Wasserman KWK: *Genetics and Changing Concepts*, (9th edn). London: Smith and Smith, 2000.

CHAPTER



36

Pediatric Neuromuscular Disorders

Vishnu Bhat B, Suraj Gupte

INTRODUCTION

The term, *neuromuscular disorders*, includes the diseases of the motor unit which has four components:

- Motor neuron in the brainstem or ventral horn of the spinal cord
- Peripheral nerve
- Neuromuscular junction, and
- Muscle fibers innervated by a single motor neuron.

Though motor unit is under upper motor neuron control, upper motor neuron (suprasegmental) disorders such as cerebral palsy are not included under neuromuscular disorders.

Clinical evaluation of the neuromuscular system should never miss out on muscle bulk, tone and strength.

In laboratory evaluation, important investigations include serum enzymes like creatine phosphokinase (CPK), nerve conduction velocity (NCV), electromyography (EMG), muscle biopsy (most vital), nerve biopsy (usually sural nerve biopsy), electrocardiography (ECG) and serial pulmonary function tests.

NEUROMUSCULAR TRANSMISSION DISORDERS

Myasthenia Gravis

This condition occurring secondary to an autoimmune reaction against acetylcholine receptors is uncommon in *pediatric practice*. Three types are recognized:

1. Transient neonatal myasthenia gravis.
2. Persistent neonatal myasthenia gravis.
3. Juvenile myasthenia gravis.

Transient neonatal myasthenia The baby acquires it from the mother with established mild or even unre-

cognized disease. He is floppy and weak with poor feeding, feeble cry, feeble respiratory effort, lots of oral secretions and ptosis. However, he is alert and has normal deep tendon reflexes.

Response to edrophonium/neostigmine (IM) is excellent.

Without treatment, most babies show spontaneous recovery in 2 to 4 weeks but death may occur within hours or days.

Persistent neonatal myasthenia gravis There is no evidence of the disease in the mother. The symptoms are those encountered in the first type plus severe involvement of the eyelids and extraocular muscles. Risk to siblings is high. It is likely to persist throughout life.

Juvenile myasthenia gravis This occurs usually after 10 years of age with remarkably high incidence among girls, the girls: boys ratio being 6:1. The weakness is aggravated on repetitive movements and regresses on rest. Following or during stress such as an infection or surgery, life threatening *myasthenia crisis* may occur. In very severe form, generalized muscle paralysis may occur.

Diagnosis is confirmed by edrophonium/neostigmine test and, if possible, by electric testing of neuromuscular transmission.

With treatment employing anticholinesterase agents such as pyridostigmine bromide, neostigmine or ambenonium, 25% of the patients have complete cure and most patients can lead almost normal life.

MOTOR NEURON DISORDERS

These include spinal muscular atrophy (SMA), poliomyelitis, polio-like illness caused by such viruses as

Coxsackie and ECHO virus, juvenile form of amyotrophic lateral sclerosis, Pena-Shokeir syndrome and Marden-Walker syndrome.

SPINAL MUSCULAR ATROPHIES (SMA)

SMA is a degenerative disorder of motor neurons beginning in fetal life and continuing in infancy and childhood. It is the second most common neuromuscular disorder after Duchenne muscular dystrophy.

Classification

1. SMA type 1 or Werdnig-Hoffmann disease which is a severe form.
2. SMA type 2 which is a late infantile and slowly progressive form, and
3. SMA type 3 or Kugelberg-Welander disease which is a more chronic or juvenile form.

Etiopathogenesis

The diseases are inherited as autosomal recessive, the defective gene being on chromosome 5 at 5q11-13 locus.

The basic pathologic defect is a remarkable loss of anterior horn cells, usually from the entire length of the spinal cord.

Clinical Features

The common features are:

- Positive family history.
- Absence or reduction of fetal movements *in utero*.
- Gross hypotonia and areflexia in an otherwise normal child, generally at or soon after birth.
- Muscle involvement is symmetrical though proximal parts are more affected. Spontaneous movements, atrophy and fasciculation of tongue may occur.

In most instances, it progresses rapidly and proves fatal, in many cases during infancy itself. The cause of death is neurologic involvement of muscles of thorax, respiratory failure and/or fulminant infection.

The survivors are in a completely helpless condition and susceptible to infections.

Diagnosis

Muscle biopsy shows the classical features of denervation atrophy with large patches of small,

atrophic fibers residual muscle fibers of normal or somewhat enlarged diameter. Sural nerve biopsy may show sensory neuropathic changes.

Treatment

Treatment is symptomatic. Nothing seems change the course and prognosis of the disease.

DEVELOPMENTAL (CONGENITAL) DISORDERS OF MUSCLES

The term refers to an heterogeneous group of congenital neuromuscular disorders such as myotubular myopathy, congenital muscle fiber type disproportion (CMFTD), nemaline rodmyopathy, central core disease, benign congenital hypotonia, amyoplasia, muscular dysgenesis and arthrogyposis.

MYOTUBULAR MYOPATHY (Centronuclear Myopathy)

In this X-linked recessive disorder, genetic linkage is localized to the Xq28 site which is different from the Xp21 gene of Duchenne and Becker myopathies. There is a maturational arrest of fetal muscle during the myotubular stage of development at 8-15 week of gestation.

Manifestations include decreased fetal movements, reduced muscle mass with gross hypotonia and poor respiratory efforts warranting ventilatory support, poor sucking and deglutition warranting gavage feeding, high-arched palate, ophthalmoplegia, thin tongue, absent or weak tendon reflexes.

Muscle biopsy is diagnostic at birth. Prognosis is poor. Only 25% of the neonates with this disorder manage to survive. They are left with major physical handicaps, including severe hypotonia.

BENIGN CONGENITAL HYPOTONIA

This condition, which may be familial in certain cases, is characterized by extreme hypotonia without delay in motor development. Tendon stretch reflexes are hypoactive or normal and there are no cranial nerve abnormalities. IQ is by and large within normal range. Most of the subjects recover fully by 8 to 10 years of age. Others have a stationary and nonprogressive course. Joints are always hypermobile.

The infant's muscles are soft and flabby and remarkable range of movements is possible. Unlike *Werdnig-*

Hoffmann disease, the fetal movement are normal. Spontaneous movements are more prominent, and respiratory involvement is unusual.

Diagnosis is by exclusion of other causes of floppiness (hypotonia). Muscle biopsy and brain imaging (with special reference to cerebellum) are normal.

Complications include recurrent dislocation of shoulder and other joints and spine-related problems such as compression, stretch injury or compromise of nerve roots.

Prognosis is generally good. No specific treatment is indicated.

MUSCULAR DYSTROPHIES

The Greek term *dystrophy* (*dys* meaning aberrant and *trophy* meaning nourishment) implies aberrant growth or nutrition of muscle fibers. Muscular dystrophies are a heterogeneous group of unrelated inherited disorders having different genetic trait and different clinical course and expression.

Muscular dystrophies have four obligatory criteria that distinguish them from other neuromuscular disorders, namely:

- They are primary myopathies
- They have genetic basis
- They have progressive downhill course
- They have degeneration and death of muscle fibers at some stage.

PSEUDOHYPERTROPHIC MUSCULAR DYSTROPHY

Duchenne Muscular Dystrophy (DMD)

This, the most common form of progressive muscular dystrophies, is transmitted in a X-linked recessive manner (affecting only males and carried by females), manifests before the fifth year of life and generally proves fatal in the second decade.

Etiopathogenesis

Four hypotheses have been suggested (Table 36.1).

Pathologic changes include various stages of necrosis of muscle fibers, phagocytosis of degenerating fibers, abnormally small fibers and increase in fat and endomysial connective tissue. There are signs of regeneration which eventually disappear.

Table 36.1: Hypotheses about DMD pathogenesis

- Muscle lesions are secondary to microinfarcts as a result of disordered circulation.
- Muscle lesions are due to neuronal dysfunction
- Genetic defect in muscle surface membranes.
- Defective DNA repair mechanism as a result of insult from some DNA-damaging agent e.g. ionizing radiation or similar injury.

Notwithstanding the X-linked recessive inheritance, some 30% subjects with DMD are new mutations without the mother being a carrier. Occasionally, DMD in its mild form may be encountered in girls. It appears that in these girls, the normal X chromosome becomes inactivated but that with gene deletion becomes active (Lyon hypothesis). In girls with Turner syndrome (45 XO), full blown DMD may occur when the X chromosome has the Xp21 gene deletion.

Clinical Features

The earliest manifestations include difficulty in standing or walking, climbing stairs, arising from the floor or other activities involving the muscles of the pelvis. If picked up by the axillae, the boy may manifest hypotonia as early as 2 years. Early hypertrophy of calf muscles is also a useful sign. A *waddling gait* (*Trendelenburg gait*) may be noticed. The patient may find it difficult to comb his hair or raise his hands above the head.

A classical case shows a characteristic manner of arising from the bed to an upright position as is demonstrated in Figures 36.1 to 36.3. This succession of movements is aptly described as “climbing up one’s own thighs” (Gowers sign). Lordosis and forwardly-thrust tummy are outstanding when the child stands upright. Pseudohypertrophy, especially of the calf muscles is striking (Fig. 36.4). Tendon reflexes are sluggish or absent; ankle reflex is an exception. Cardiac enlargement, persistent tachycardia and cardiac failure occur in nearly all cases some time during the disease. About 20 to 30% cases have mental deficiency. Intellectual impairment is a constant feature of the disease.

Diagnosis

The clinical impression may be supported by the following investigations:

- CPK: remarkably high.

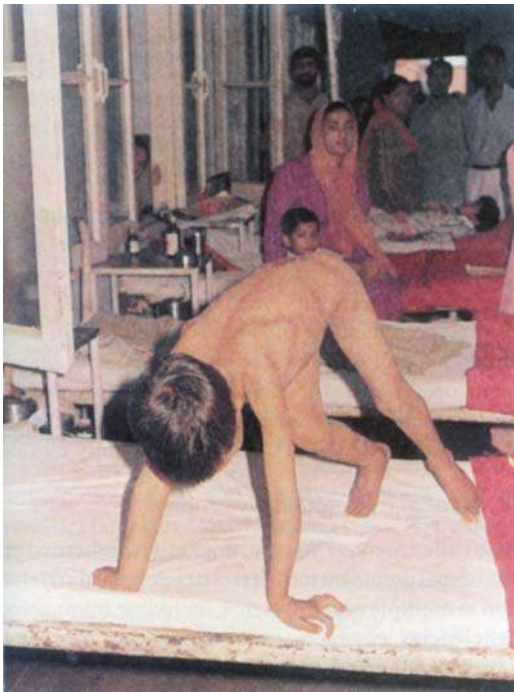

Figs 36.1 to 36.3: *Pseudohypertrophic muscular dystrophy*. Note the classical Gowers sign, i.e. succession of movements involved in arising from bed to an upright position. The child appears to be climbing up his own thighs

- EMG: Reduced amplitude and duration of motor unit potentials.
- Muscle biopsy: Changes described under "pathology".
- ECG: Tall right precordial R waves; deep Q waves in limb or left precordial leads. In differential diagnosis, such entities as late Werdnig-Hoffmann disease, endocrinal myopathy, cerebral palsy, glycogen storage disease and polymyositis should be considered.

With the new developments in molecular genetics of DMD, molecular diagnosis is likely to take over CPK and muscle biopsy in detecting carrier state.

Treatment

No effective treatment is as yet available. Chronic steroid therapy gives gratifying initial results with improvement in muscle strength. But, it is accompanied by adverse side-effects.



Fig. 36.4: Pseudohypertrophic muscular dystrophy. Note the remarkably bulky calf muscles

Molecular genetic engineering is expected to provide cure for DMD through one of the following three approaches:

1. Myoblast transfer (transplant) therapy
2. Introduction of a recombinant dystrophin gene ligated to an appropriate promoter by intramuscular injection
3. Use of retroviruses with viral DNA incorporating the deleted nucleotide sequences of the dystrophin gene.

Prognosis

Virtually all subjects become bedridden by 12 years of age. About 75% die before the age of 20 years, usually from cardiomyopathy or pulmonary complications.

Prevention

Detection of female carriers by serum CPK estimation or quantitative EMG and genetic counseling based on localization of the gene using DNA polymorphism are important.

Becker Muscular Dystrophy

This type of pseudohypertrophy muscular dystrophy differs from Duchenne muscular dystrophy in the following ways:

- Onset of weakness is later.
- Follows a relatively slower, protracted course.
- Affected boys remain ambulatory for 16 years of age or beyond against just 12 years in Duchenne muscular dystrophy.
- Death occurs in 20s or 30s, some living up to or beyond 40 years of age.

Scapulo-peroneal or Scapulo-humeral Muscular Dystrophy

Also termed *Emery-Dreifuss muscular dystrophy*, this entity too has X-linked recessive inheritance. Like Becker muscular dystrophy, it has slow progression so that many subjects survive to late adult life. However, contractures at elbow and ankles develop from middle childhood and muscles become wasted in a scapulo-humeroperoneal distribution. Hypertrophy of calves does not occur and facial muscles are spared. Cardiomyopathy is more severe. Serum CPK is only slightly elevated.

Myotonic Muscular Dystrophy

Also called *Steinert disease*, this entity is inherited as an autosomal dominant trait. It is characterized by dysfunction in multiple organ systems, including immunologic deficiencies, cataracts, endocrinopathies, dysmorphic facies, intellectual impairment and other neurologic abnormalities. Characteristic facies are present in infancy with wasting or weakness, inverted V-shaped upper lip, thin cheeks and loss of muscle mass in the temporal fossae. Also present are hypotonia, narrow head and high-arched palate. Myotonia, meaning a very slow relaxation of muscles after contraction, becomes evident usually after 5 years of age.

In a *severe neonatal form* of the disease, occurring in offsprings of mothers with myotonic dystrophy, manifestations include club foot, contractures of multiple joints, generalized hypotonia and muscle weakness. Respiratory muscle weakness or apnea together with abdominal distention may necessitate gavage feeding or ventilator support.

Differential diagnosis is from other rarer conditions with myotonia. *Myotonic chondrodystrophy* (Schwartz-Nakpel disease), generalized muscular hypertrophy, giving the child appearance of a body-

builder, though the large muscles are in fact weak or outstanding. *Paramyotonia* is characterized by myotonia that is aggravated by exposure to cold.

Limb-Girdle Muscular Dystrophy

This usually autosomal recessive (occasionally autosomal dominant) disorder is characterized by late onset of manifestations (middle or late childhood), involvement of muscles of hip and shoulder girdles and, later, distal muscles. Hypertrophy of calves and contractures of ankles occur in some patients. There is usually no cardiac involvement and IQ is normal.

Facioscapulohumeral Muscular Dystrophy

Also termed Landouzy-Dejerine disease, it has autosomal dominant inheritance and is characterized by late onset (around puberty) and slow progression. Manifestations include facial and shoulder girdle weakness followed by weakness of the muscles of the hips and anterior tibial and peroneal muscles. Thus, rounded and plucked mouth, inability to close the eyes fully in sleep, inability to whistle or hold air in the buccal cavity, scapular winging, foot drop and positive Gowers sign and Trendelenburg gait are outstanding signs. Hypertrophy of calves is not present.

Congenital Muscular Dystrophy

The term includes a group of dystrophies with autosomal recessive inheritance, onset right at birth, and a benign course. Arthrogryposis is present in all. Muscles of trunk and limbs are thin. Facial muscles are minimally affected. Tendon reflexes are poorly elicited or absent.

In the commonest form, *Fukuyama type*, encountered in children of Japanese, Dutch, German, Scandinavian and Turkish ethnic background, additional features are cardiomyopathy, mental retardation, seizures, microcephaly and growth failure. Muscle biopsy is diagnostic as early as in neonatal period.

ENDOCRINAL MYOPATHIES

Steroid-induced Myopathy

Myopathy in *Cushing disease* (natural) and *Cushing syndrome* (iatrogenic; usually exogenous fluorinated

steroids like dexamethasone) is characterized by proximal weakness, high serum CPK, a myopathic EMG and a myopathic muscle biopsy.

Myopathy in *Conn syndrome*, also called hyperaldosteronism, is characterized by reversible periodic weakness, high serum CPK and even myoglobinuria in acute episode.

Thyroid Myopathy

Thyrotoxicosis causes myopathy in three different ways, namely: (i) binding excess thyroxine to myofibrils and impairing the contractibility, (ii) inducing myasthenia gravis, and (iii) inducing hypokalemic periodic paralysis (vide infra).

In hypothyroidism, muscle weakness and hypotonia is a leading finding. In Kocher-Debre-Semelaigne (KDS) syndrome, hypertrophy of the affected muscles is an additional feature.

Parathyroid Myopathy

In primary hyperparathyroidism, reversible fatigability, weakness and muscle wasting are important features.

METABOLIC MYOPATHIES

This group includes potassium-related periodic paralysis, malignant hyperthermia, glycogenosis, mitochondrial myopathies, lipid myopathies, and vitamin E deficiency myopathy.

Potassium-related Periodic Paralysis

Hypokalemia and, less frequently, hyperkalemia cause episodic weakness or paralysis. The condition has an autosomal dominant inheritance.

Manifestations include inability of the patient to move after awakening for a few minutes to hours. In children, the period in between episodes is symptomfree. But, as the child grows to adulthood, frequency of episodes increases. Eventually the patient remains symptomatic permanently.

Only during acute episodes, serum potassium level shows alteration, ECG the T wave changes, CPK slight elevation, and the muscle biopsy a vacuolar myopathy.

OTHER MYOPATHIES

Myopathy may accompany inflammatory conditions like dermatomyositis, polymyositis, focal myositis, SLE, and parasitic myositis (trichinosis), as also trisomy 13-15.

HEREDITARY MOTOR-SENSORY NEUROPATHIES (HMSN)

This is a group of progressive disorders of peripheral nerves, namely peroneal muscular atrophy (HMSN type I), peroneal muscular atrophy, axonal type (HMSN type II), Dejerine-Sottas disease (HMSN type III), Roussy-Levy syndrome, Refsum disease, giant axonal neuropathy, congenital hypomyelinating neuropathy and leukodystrophies.

AUTONOMIC NEUROPATHIES

This group includes familial dysautonomia (Riley-Day syndrome), myenteric plexus neuropathies (Hirschsprung disease), reflex sympathetic dystrophy and congenital insensitivity to pain and anhidrosis.

GUILLAIN-BARRÉ SYNDROME

See Chapter 23 (Pediatric Neurology).

BELL'S PALSY

See Chapter 23 (Pediatric Neurology).

FLOPPY BABY SYNDROME

The term refers to a large group of conditions associated with excessive hypotonia (Table 36.2).

Table 36.2: Causes of floppy baby syndrome

- *Benign Congenital Hypotonia*
- *Chromosomal Disorders* Down syndrome, trisomies 13-15.
- *Neurologic Disorders* Atonic cerebral palsy, poliomyelitis, glycogen storage disease, cerebral lipidosis, congenital myopathy, myasthenia gravis, polyneuritis polymyositis (dermatomyositis), Werdnig-Hoffmann disease, Prader-Willi syndrome
- *Miscellaneous Disorders* Advanced PEM, rickets, scurvy, cretinism, acrodynia, Ehlers-Danlos syndrome, Infant botulism, kernicterus

The term must be reserved for infants suffering from severe hypotonia involving all the skeletal muscles.

The floppy infant often assumes a frog-legged posture. He offers little resistance to passive movements of the extremities. There is increased range of movements at the joints. The assumption of the so-called "rag-doll" position on ventral suspension is characteristic. An attempt to pull him up from supine position to sitting position is accompanied by head lag.

All floppy infants must be evaluated for mental retardation and seizures, especially if the cause of floppiness appears to be CNS related. Feeding problems are a common occurrence in these infants.

FURTHER READING

Articles/Chapters

1. Houffin Debarge V, Delsalla A, Subtil D, *et al*: Fetal cells in the maternal blood: A step towards noninvasive prenatal diagnosis. *J Gynecol Obstet Biol Reprod Paris* 1998;27:483-493.
2. Kulkarni ML. Muscular dystrophies. In Gupte S (Ed): *Recent Advances in Pediatrics*-10. New Delhi: Jaypee 2000;60-84.

Book/Monograph

1. Gupte S. *Recent Advances in Pediatrics (Special Vol 18: Pediatric Neurology)*. New Delhi: Jaypee 2008.

PART FIVE

Pediatric Superspecialties





Pediatric Ophthalmology

Vijay Wali, Suraj Gupte

DEVELOPMENTAL ASPECTS

The neonate's cornea is around 10 mm in diameter and reaches 12 mm, the adult size, by 2 years. His eye is, however, only 2/3rd of the adult size. Though perfectly clear in normal neonates, cornea may be slightly hazy in prematures. The lens is more spherical with greater refractive index to make up for the shortness of his eye. The pupils are small, difficult to dilate and often reveal anterior vascular capsule remnants as cobweb-like lines crossing the aperture, in premature infants in particular. Because of its thinness, sclera is bluish in color. Transient conjunctival hemorrhages may be seen.

The fundus of the neonate is less pigmented, often showing prominent vascular pattern and peppery or mottled appearance of retinal pigmentary pattern. The foveal light and other macular landmarks are poorly defined. The peripheral retina is particularly pale. Transient superficial retinal hemorrhages may be encountered. Appearance of fundus tends to come close to that of the mature eye by the age of 4 to 6 months.

Generally, the neonate's eye is hypermetropic (far-sighted); though most prematures are myopic with some astigmatism. Inclined to keep eyes closed most of the time, he is capable of seeing, reacting to changes in light, and fixating points of contrast. The visual acuity of 20/40 tends to reach 20/30 to 20/20 by the age of 2 to 3 years. He evinces more sustained interest in large objects by 2 weeks and can follow an object through an arc of 180° by the age of 8 to 10 weeks.

The imperfect coordination of eye movements and alignment gives way to proper coordination by 3 to 6 months.

On account of poor development of the lacrimal glands, tears often make their appearance on crying after 1 to 3 months of age

ORBITAL DISEASES

Hypertelorism

It refers to increased distance between pupils so that eyes are set widely apart. The cause is congenital overdevelopment of the lesser wings and underdevelopment of the greater wings of the sphenoid. It may be found in its mild form in normal individuals. Significant hypertelorism is, however, associated with mental retardation and other congenital anomalies (Fig. 37.1).

It may occur as a part of certain syndromes like Apert syndrome, Crouzon syndrome, Ehler-Danlos syndrome, craniocleidodysostosis and certain sex chromosomal anomalies.



Fig. 37.1: Hypertelorism. Note the increase in interpupillary distance

Presence of flat nose, especially with epicanthal fold, as in Down syndrome, cretinism and mongolian races, may give an impression of an abnormally large distance between the eyes. This is called *pseudohypertelorism*.

The most accurate measure of hypertelorism is the direct measurement of the interpupillary distance with a calliper. This is, however, not quite practical in infants without obtaining full dilatation of the pupils under anesthesia. In clinical workup, therefore, interpupillary distance may be derived from any of the following two equations:

$$\begin{aligned} \text{Interpupillary distance} \\ = 0.7 + 0.59 \text{ innercanthal distance} \\ + 0.41 \text{ outer canthal distance} \end{aligned}$$

or

$$\frac{\text{Outer canthal distance} - \text{Inner canthal distance}}{2}$$

The first equation is said to be more reliable.

After obtaining the interpupillary distance (Fig. 37.2), hypertelorism index may be calculated from the following equation:

5

$$\text{Hypertelorism index} =$$

An index exceeding 57% is indicative of hypertelorism.

Hypotelorism

Decreased interpupillary distance may be accompanied by high incidence of mental retardation, hydrocephalus, and epilepsy. In addition to an isolated form, it is also seen in oculodentodigital syndrome, cyclops holoprosencephaly, and trigonocephaly (Table 37.1).

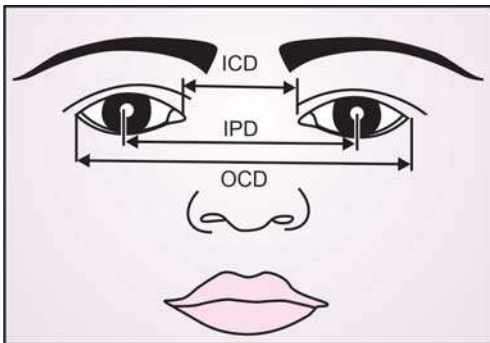

Fig. 37.2: Ocular landmarks. ICD: intercanthal distance; IPD: interpupillary distance; OCD: outer canthal distance. Presence of hypertelorism or hypotelorism is confirmed by measurement of interpupillary distance (IPD)

Table 37.1: Important causes of true hyper- and hypotelorism

<i>Hypertelorism</i>	<i>Hypotelorism</i>
Trisomy 8	Trisomy 13
4p-	Holoprosencephaly
5p-	Trigonocephaly
Triploidy syndrome	Oculodental digital syndrome
Penta X, XXXX, XXXXX	
Aarskog syndrome	
Williams syndrome	
Noonan syndrome	
Fetal aminopterin syndrome	
Fetal hydantoin syndrome	
Fetal warfarin syndrome	
Apert syndrome	
Pfeiffer syndrome	
Saethre-Chotzen syndrome	
Robert syndrome	
Rubinstein-Tayabi syndrome	
G syndrome	
Robinow syndrome	
Weaver syndrome	
Hypertelorism-hypospadiasis syndrome	
Solos syndrome	
Larsen syndrome	
Pyle disease	
LEOPARD syndrome	
Sjögren-Larsen syndrome	
DiGeorge sequences	

Exophthalmos (Proptosis)

The protrusion of the eye is caused by shallowness of the orbit (craniosynostosis, other craniofacial malformations), by relatively increased tissue mass (cellulitis, cavernous sinus thrombosis, orbital hemorrhage, neoplasm) or by endocrinopathy (thyrotoxicosis). It may be complicated by exposure keratitis, ocular motor disturbances, optic atrophy and blindness.

Enophthalmos

The posterior displacement (sinking) of the eye back into the orbit occurs following atrophy of the orbital tissue or orbital fracture. It classically occurs in Homer syndrome (other features: ptosis, absent ciliospinal reflex, anhidrosis, miosis) which results from lesions of the lower cervical and upper thoracic sympathetic nerve fibers.

Microphthalmia

Developmentally small eye may well be a feature of certain intrauterine infections (toxoplasmosis, rubella,

Table 37.2: Staging of orbital cellulitis

Stage I	: Swelling limited to lids, some reactive periostitis
Stage II	: Periosteal abscess with localized tenderness, proptosis and some limitation of eye movements
Stage III	: Diffuse orbital tissue inflammation, proptosis, limitation of eye movements
Stage IV	: Orbital abscess

cytomegalic virus) and Down syndrome. Often, it is accompanied by microcornea (anterior microphthalmia).

Orbital Cellulitis

Inflammation of the tissues of the orbit with proptosis, limitation of the eye movements, and edema/swelling of the conjunctiva (chemosis) and eyelids may follow direct extension of infection involving neighboring structures (the commonest being paranasal sinusitis), direct infection of the orbit, or superadded infection of an orbital tumor (metastatic or primary) (Fig. 37.3).

The causative organisms, in order of frequency are *H. influenzae*, *Staphylococcus aureus*, group A beta-hemolytic streptococci and *Streptococcus pneumoniae*.

The orbital cellulitis associated with paranasal sinusitis is categorized as per Table 37.2.

Complications include blindness from involvement of optic nerve and cavernous sinus thrombosis, meningitis or, epidural, subdural or brain abscess.



Fig. 37.3: *Orbital cellulitis.* Note the extensive pyoderma involving the face and ears. Besides inflammation of the lids and conjunctiva, the child had proptosis and limitation of eye movement

Orbital cellulitis requires to be aggressively treated with systemic antibiotics plus surgical drainage of the sinus or abscess, if indicated.

Periorbital (Preseptal) Cellulitis

This term is applied to inflammation of the lids and periorbital tissues without evidence of true orbital involvement in the form of proptosis or limitation of eye movements. It may be the first sign of sinusitis and may progress to true orbital cellulitis.

It must be treated with prompt antibiotic therapy.

Tumors

Orbital tumors may be benign (hemangioma, dermoids) or malignant (rhabdomyosarcoma, lymphosarcoma, metastatic neuroblastoma, optic glioma, retinoblastoma).

Manifestations include proptosis, limitation of eye movements, a palpable mass, ptosis, optic nerve head congestion, optic atrophy and blindness. Detection of bruit and apparent pulsation of the globe points to a vascular lesion.

Diagnosis is supported by ultrasonography, CT scan and MRI.

DISEASES OF THE EYELIDS

Ptosis

Drooping of the upper eyelid so as to cover more than 2 mm of the cornea below the upper limbus is termed *ptosis*. It may be *congenital* due to faulty development of the levator muscle or its innervating branches of the 3rd cranial nerve, or *acquired* due to myasthenia gravis. Horner syndrome, Sturge-Weber syndrome, von Recklinghausen syndrome, injury to upper lid or 3rd nerve, drugs like vincristine, etc.

Congenital ptosis may be familial, transmitted as a dominant trait, and occur with a number of syndromal states such as Marcus Gunn jaw winking syndrome and congenital fibrosis syndrome.

Ptosis may often be accompanied by squint and/or anisometropia, eventually ending up with amblyopia. Surgical correction in mild cases should be deferred until age of 3 to 4 years. In moderate to severe cases, early correction to prevent amblyopia is recommended.

Lagophthalmos

Complete closure of the lids over the globe may be difficult because of paralysis (facial palsy involving orbicularis muscle), spasm (thyrotoxicosis), structural (scarring/atrophy secondary to burns or injury), or physiologic (during sleep).

Management consists in protecting the eye by artificial tear preparations, eye ointment, moisture chambers, and surgical closure of the lids (tarsorrhaphy).

Lid Retraction

It means that the upper lid rests above the upper limbus. It may be myogenic (thyrotoxicosis), neurogenic (anterior mesencephalic involvement, hydrocephalus), meningitis, or paradoxical (Marcus Gunn jaw winking syndrome), or physiologic/reflective (eye popping).

Entropion

Inward turning (inversion) of the lid margin may be congenital or secondary to scarring from trachoma, Stevens-Johnson syndrome or some other inflammation. Inward turning of the eyelashes (trichiasis) may cause discomfort and even corneal damage. Surgical correction is often effective.

Ectropion

Outward turning (eversion) of the lid margin may result from scarring following inflammation, burns or trauma, weakness of the orbicularis muscle (facial palsy), or faulty development of the lateral canthal ligament (Down syndrome). It may be complicated by an overflow of tears (epiphora), maceration of skin of the lid, conjunctivitis, or keratopathy.

Blepharospasm

Repetitive or spastic closure of the lids may occur as tics or secondary to trichiasis, keratitis, conjunctivitis, foreign body, fatigue, or uncorrected refractive error.

Botulinum toxin injected locally may be of value.

Blepharitis

Inflammation of the lid margin, either staphylococcal or seborrheic in etiology, may manifest with irritation, burning, itching, erythema and crusting or scaling of lid margins.

Treatment consists in daily cleansing of the lid margins and application of antistaphylococcal ophthalmic ointment locally. Antiseborrheic treatment of scalp in case of seborrheic blepharitis is warranted.

Hordeolum

Infection of the glands of the lid, usually due to *Staphylococcus aureus*, manifests as tender focal swelling and erythema. It may be of two types, namely:

1. *External hordeolum (Stye)* when involvement is of glands of Zeis or Moll. Here the abscess points at the lid margin and is small and superficial
2. *Internal hordeolum* when involvement is of the meibomian glands. Here the abscess is large and points through skin or conjunctival surface. Treatment is frequent warm compresses, topical antibiotic applications, and, if necessary, surgical incision and drainage. Left untreated, hordeolum may be complicated by cellulitis. Recurrent hordeolum signals reinfection, underlying allergy, or an immunologic defect.

Chalazion

Unlike internal hordeolum, chalazion is a granulomatous inflammation of a meibomian gland. The lesion is a chronic, firm, nontender nodule in the lid.

If it does not subside spontaneously and is large enough, it should be excised. Else, it may cause astigmatism by pressure on the eyeball in addition to a cosmetic defect.

Coloboma

It is a cleft-like deformity, often accompanied by a dermoid cyst, dermolipoma, and extensive facial malformations (mandibulofacial dysostosis in the form of Treacher-Collins syndrome). It must be surgically corrected to prevent ophthalmic complications because of exposure of the globe.

Tumors

Among the tumors of the lid figure nevi, hemangioma, lymphangioma, plexiform neuromas, basal cell carcinoma, squamous cell carcinoma, adenoma subaceum and malignant lesions of xeroderma pigmentosum and Rothmund-Thomson syndrome.

Tumors such as retinoblastoma, neuroblastoma and rhabdomyosarcoma may also involve the lids.

DISEASES OF THE LACRIMAL SYSTEM

Congenital Nasolacrimal Duct Obstruction (CNLDO)

Also termed *dacryostenosis*, it occurs in 5% of the neonates due to incomplete canalization of the nasolacrimal duct with a residual membrane at the lower end of the duct at its entry into the nasal cavity.

Manifestations include excessive tearing, ranging from “wetness” of the eye to frank overflow of tears (epiphora), accumulation of mucoid or mucopurulent discharge, crusting, erythema and maceration of the skin and, in some instances, reflux of fluid or discharge on massaging the nasolacrimal sac.

Differential diagnosis is from intraocular inflammation, glaucoma, or external irritation from a foreign body or corneal abrasion.

Treatment consists in giving nasolacrimal massage, 2 to 3 times/day, along with cleansing of the lids with warm water. In case of significant mucopurulent discharge, topical antibiotics are indicated. This conservative regimen resolves the problem by the age of 1 year. In case of failure of this treatment, probing is indicated. Probing may have to be repeated once or twice.

A very small proportion of subjects, failing to respond to repeated probing, need placement of tubes or extensive reconstructive surgery in the form of dacryocystorhinostomy.

Dacryocystitis

Frank inflammation of the lacrimal sac may occur as a complication in CNLDO. The sac area becomes swollen, red and tender. Systemic signs of infection like fever and irritability are usually present.

Therapy comprises of prompt treatment with antibiotics with surgical intervention.

Alacrima (Dry Eye)

Noteworthy deficiency of tears, leading to dryness of eyes, corneal ulceration and scarring, may occur as a congenital defect (isolated or in association with aplasia of cranial nerves, familial dysautonomia or Riley-Day syndrome, anhidrotic type of ectodermal

dysplasia, glucocorticoid deficiency), or secondary to inflammation, Stevens-Johnson syndrome, dehydration, etc.

Treatment consists in frequent instillation of an artificial tear preparation. In case of unsatisfactory response, occlusion of the lacrimal puncta and even tarsorrhaphy may be carried out for protecting the cornea.

CONJUNCTIVAL DISEASES

Conjunctivitis

Inflammation of conjunctiva, as a reaction to a wide variety of agents, may be infectious or noninfectious.

Infectious conjunctivitis may be caused by viruses (measles and other exanthemata, adenovirus type 8) (Fig. 37.4), or bacterial (*H. influenzae*, *N. gonorrhoeae*, *Chlamydia*, *Pseudomonas*, *S. pneumoniae*, *Staphylococcus*, *Streptococcus*, *C. diphtheriae*).

Noninfectious conjunctivitis may occur as a reaction to allergens (endogenous: phlyctenular, exogenous, vernal/spring catarrhic), irritants/toxins (chemical conjunctivitis from silver nitrate, household cleaning agents, sprays, smoke smog, industrial pollutants), and systemic diseases (Reiter's disease, Stevens-Johnson syndrome).

Ophthalmia neonatorum (neonatal conjunctivitis) is described in Chapter 17 (Neonatology).

Subconjunctival Hemorrhage

Bright or dark-red hemorrhages in bulbar conjunctiva, of varying shape and size, may be encountered as a result of violent coughing (pertussis), sneezing, injury, inflammation or blood dyscrasia (leukemia, scurvy, ITP).



Fig. 37.4: Vernal conjunctivitis. Note the marked hypertrophy and increased pigmentation of the conjunctiva at the limbus

Chemosis

Conjunctival edema/swelling may occur in orbital cellulitis, cavernous sinus thrombosis, angioneurotic edema, urticaria and acute nephritis.

Pingueculum

It is a somewhat raised mass on bulbar conjunctiva, usually in interpalpebral region, representing elastic and hyaline degenerative changes of the conjunctiva. No treatment is warranted.

Pterygium

It is a fleshy triangular conjunctival lesion which classically occurs in the nasal interpalpebral region and tends to encroach on the cornea. Encroachment far onto cornea warrants surgical removal.

Dermoid Cyst/Dermolipoma

These similar lesions are smooth, elevated, round or oval, and vary in color from yellowish-white to a fleshy pink. They usually occur in upper outer quadrant of the globe.

Conjunctival Nevus

This, usually a benign lesion, varies in pigmentation from pale salmon patch to dark brown.

Symblepharon

This is a cicatricial adhesion between the globe and usually the conjunctiva of the lower lid. It follows surgery, injury (burns from acids or molten metal), or as a complication of Stevens-Johnson syndrome.

Manifestations include diplopia and interference with mobility of the eyeball.

Surgical separation of the adhesions is warranted.

CORNEAL DISEASES**Megalocornea**

A cornea of more than 13 mm diameter, often familial and associated with other developmental disorders (osteogenesis imperfecta, Marfan syndrome), is usually accompanied by refractive errors. In adults, there is high incidence of glaucoma, subluxation of lens and premature development of cataracts.

Differential diagnosis is from pathologic corneal enlargement from glaucoma.

Microcornea (*Anterior Microphthalmia*)

An abnormally small cornea may be familial or a feature of a developmentally microphthalmic eye. Colobomata, congenital cataract, glaucoma, aniridia and microphakia are the associated defects.

Keratoconus

Cone-shaped cornea as a result of its thinning and bulging at the center occurs either sporadically or in association with atopy, Marfan syndrome, Down syndrome and retinitis pigmentosa. Hard contact lenses and, sometime, corneal transplantation may be needed.

Sclerocornea

The normal translucent cornea is replaced by a sclera-like vascularized and ill-defined tissue, usually at the periphery. It generally occurs in association with other ophthalmic anomalies and CNS, chromosomal and skeletal defects.

Dendritic Keratitis

The branching tree-like lesion, due to herpes simplex virus, is accompanied by conjunctivitis, pain, photophobia, tearing and blepharospasm. Topical 5-iodo-2-deoxyuridine (IDU) is the treatment of choice.

Interstitial Keratitis

Inflammation of corneal stroma, usually secondary to syphilis and less often tuberculosis or leprosy, manifests with pain, photophobia, tearing circumcorneal congestion and hazy cornea. Eventually, it ends up as corneal vascularization and opacities.

Phlyctenules (*Phlyctenular Keratoconjunctivitis*)

Small, yellowish, somewhat raised lesions, located at the limbus and encroaching onto cornea, often with an ulcer at the advancing head, may well be an allergic reaction to tuberculin protein. In some cases, it may be associated with staphylococcal infection. A strong immunologic factor appears to be in operation. Response to topical steroids is gratifying.

Corneal Ulcers

Corneal ulcers may result from trauma (foreign body), malnutrition (xerophthalmia), adjoining ophthalmic infection (conjunctivitis, dacryocystitis), exposure (exophthalmos, lagophthalmos), diminished sensations (Riley-Day syndrome), exanthemata, or metabolic disorders (tyrosinemia).

Manifestations include corneal haziness, hyperemia, lid edema, pain, photophobia, tearing and blepharospasm. Pus may accumulate in the anterior chamber (hypopyon).

Pathogens causing corneal ulcers include *Pseudomonas aeruginosa*, *N. gonorrhoeae* and some fungi.

Prompt treatment, both local and systemic, with attention to causative factor(s) is warranted to safeguard against blindness.

Peter's Anomaly

This is a congenital corneal opacity (leukoma) with corresponding defects in the anterior chamber and iris.

PUPILLARY AND IRIS ABNORMALITIES

Aniridia, meaning iris is only rudimentary, may be isolated (AN-1), associated with Wilms' tumor, genitourinary anomalies, mental retardation (AN-2), or accompanied by cerebellar ataxia, congenital cataracts, and mental retardation (AN-3).

Iris coloboma is a developmental hole, notch or defect in the iris, that may occur alone or together with other coloboma or other anomalies.

Congenital microcoria/miosis is the absence/defect of dilator pupillae muscle, resulting in a very small pupil that does not easily dilate.

Congenital mydriasis is the dilated pupil with poor constriction reaction to light, near gaze and miotic agents.

Dyscoria, meaning abnormal shape of pupil, and *corectopia*, meaning abnormal pupillary position (eccentric), may occur as congenital anomalies or secondary to trauma.

Anisocoria, meaning inequality of the pupils may occur as a normal variation in healthy children or secondary to local causes (adhesions or synechia, coloboma, anirida), neurologic causes (sympathetic or parasympathetic lesions), or drugs.

Persistent pupillary membrane is persistence of remnants of pupillary membrane (which normally

disappears before birth) as weblike strands resembling spokes of a wheel in the pupil. It may interfere with vision.

Heterochromia denotes difference in color of the two irides (heterochromia iridum) or of parts of the same iris (heterochromia irides). It may occur as a congenital defect (Waardenburg syndrome), or from trauma, hemorrhage, inflammation, retinoblastoma, foreign body, glaucoma, iris atrophy and Horner syndrome.

Dilated fixed pupil is due to mydriatic drugs (atropine), internal ophthalmoplegia (central or peripheral lesions), transtentorial herniation (Hutchinson pupil), ocular trauma, iridoplegia or cholinergic supersensitivity of the sphincter (tonic pupil).

Constricted pupil is due to miotic drugs (pilocarpine, opium) barbiturate pontine hemorrhage or Horner syndrome.

Rhythmic dilatation and constriction of pupil (hippus), a normal phenomenon in some individuals, may be secondary to retrobulbar neuritis.

Leukocoria (Cat's eye reflex, white pupil) may be secondary to cataract, persistent hyperplastic primary vitreous, cicatricial ROP, retinal detachment, retinosis, larval granulomatosis, retinoblastoma, vitreous hemorrhage, leukemia, exudative retinopathy, phakematoses, etc.

DISEASE OF LENS

Cataracts

Cataract means an opacity of the lens. Table 37.3 categorizes a wide number of conditions responsible for pediatric cataracts.

Treatment is addressed to surgical removal of lens, correction of resultant aphakia, and correction of accompanying amblyopia.

Ectopia Lentis

Displacement of the lens, complete (luxation) or partial (subluxation), may accompany such systemic disorders as Marfan syndrome, homocystinuria, Weill-Marchesani syndrome, sulfiteoxidase deficiency Ehlers-Danlos syndrome, Sturge-Weber syndrome, Klippel-Feil syndrome, Crouzon syndrome, oxycephaly and mandibulofacial dysostosis.

Symptoms include blurring of vision, diplopia, refractive errors and tremulousness of the iris (iridodonesis).

Table 37.3: Etiology of pediatric cataracts**Prematurity**

Cataract of prematurity

Maternal Infections

Congenital infection syndrome: Toxoplasmosis, rubella, cytomegalovirus, herpes simplex; less often measles, poliomyelitis, influenza, varicella-zoster, vaccinia

Metabolic Disorders

Galactosemia, juvenile-onset diabetes mellitus, hypoglycemia, hypocalcemia, Wilson disease, cretinism, PKU, homocystinuria, sphingolipidosis, mucopolysaccharidosis, mucopolidosis, mucosulfatidosis

Chromosomal Disorders

13-, 18- and 21- trisomy. Turner syndrome, certain deletion and duplication syndromes

Drugs

Steroid-induced cataract, vitamin D (both hypo- and hyper), tetracyclines, chlorpromazine, radiation

Trauma

Contusion, penetrating injury, child abuse

Multisystem Disorders

Kartagener syndrome, myopathies, Marfan syndrome, Lowe syndrome, Alport syndrome

Development Variants

Mittendorf dot

5

Treatment depends on type of displacement, its cause and the presence of ocular or systemic complications. Often, the best treatment is surgical removal of the lens.

DISEASE OF THE UVEAL TRACT

Iridocyclitis, inflammation of iris and ciliary body, manifests as pain, photophobia and lacrimation. It usually accompanies pauciarticular rheumatoid arthritis, Kawasaki disease and sarcoidosis. It may also follow trauma or infective conditions in the vicinity.

Chorioretinitis, inflammation of posterior portion of uveal tract, may result from toxoplasmosis, histoplasmosis, cytomegalovirus, sarcoidosis, syphilis, tuberculosis and toxocariasis.

Panophthalmitis, inflammation of the whole eye, usually follows a perforating injury or septicemia.

EYE MOVEMENT AND ALIGNMENT DISEASES**Strabismus (Squint)**

Strabismus, meaning “to look obliquely” in Greek, occurs in some 4% of preschool children and is an important cause of visual impairment.

Orthophoria is the ideal state of perfect oculomotor balance.

Heterophoria means that the eye deviates only under certain situations like fatigue, illness, stress, or when one eye is covered.

Heterotropia means that the eye deviation is apparent (not “latent” as in heterophoria) and does not need any special situation.

Clinical Types

Two major categories are recognized paralytic and nonparalytic.

1. *Nonparalytic strabismus (concomitant)* accounts for a vast majority of the cases of strabismus. Here, individual extraocular muscles are normal. The deviation is secondary to visual or ocular defects in the involved eye.
2. *Paralytic strabismus (non-concomitant)* is due to a palsied or paretic eye muscle(s). Manifestations include diplopia, limitation of movements, false orientation of the visual field and dizziness. It may be *congenital* (neuromuscular anomalies, birth injury) or *acquired* (trauma causing fracture of the base of the skull, CNS infections, CNS tumors, encephalitic form of poliomyelitis, toxins from diphtheria, lead, botulinism, thiamine deficiency).

Third, fourth and sixth nerve palsies may well be congenital or acquired. Third and fourth nerve palsies are usually congenital whereas sixth nerve palsy is only rarely congenital.

The term, *strabismus syndromes*, refers to special forms of strabismus with unusual clinical features. These are usually caused by structural anomalies of extraocular muscles or tissues in their vicinity.

When a monocular elevation deficit in both abduction and adduction occurs, the condition is called “double elevator palsy”.

Diagnostic Tests

Corneal light reflex tests are the simplest, easiest and fastest diagnostic tool for strabismus. The Hirschberg test consists in projecting a small light onto the corneas of both eyes simultaneously and observing the reflection in each cornea as the child looks straight ahead. In a normal eye, the reflection appears centered. In an affected eye, the reflection appears off center.

The Krimsky test consists in employing prisms over the eye(s) and determining the amount of prism needed to align the reflections. This amount provides the degree of deviation in the squinting eye.

Cover tests consist of the cover-uncover test and the alternate cover test. For the first test, the child is asked to look at a distant object (about 20 ft away). Then, the examiner covers one eye and observes the movements of the other eye. If no movement is noticed, the uncovered eye is by and large normal. The procedure is repeated on the other eye.

In alternate cover test, each eye is rapidly covered and uncovered. In case of strabismus, the affected eye shows movements as the cover is shifted to the other eye.

The cover tests must be performed for both distant and near visions and in all cardinal positions of the gaze, with and without spectacles.

Treatment

It consists in correcting the refractory errors, cataracts, etc. If the strabismus persists despite this, occlusion therapy should be instituted. This consists in totally occluding the normal eye for a week or two to allow the affected eye to improve vision by continuous exercise.

Orthoptic treatment involves special visual exercises. Surgery is indicated if the child fails to respond to the aforesaid measures. It involves shortening, lengthening or repositioning of the eye muscles. As and when indicated, surgery must not be delayed.

REFRACTIVE ERRORS

A state of refractive error(s) is termed *ametropia* against the ideal optical state, *emmetropia*, in which the parallel rays of light come to focus on the retina with the eye in a state of rest.

Hypermetropia (Hyperopia)

Farsightedness occurs when the parallel rays of light are focussed behind the retina on account of too short anteroposterior diameter of the eye, subnormal refractive power of the cornea or lens, or posterior dislocation of the lens.

If the error is severe, greater accommodative effort may cause blurring of vision, eye strain, headache, fatigue, convergent strabismus, eye-rubbing and lid inflammation. Convex lenses correct the error.

Myopia

Shortsightedness occurs when the parallel rays of light come to focus in front of the retina on account of the too long anteroposterior diameter of the eye, higher refractive power of the cornea or lens, or anterior dislocation of the lens.

The major symptom is blurred vision for distant objects. The myopic child has difficulty in reading the blackboard and pursuing the distant activities. He tends to keep the book and other reading/writing matter close to his eyes. Frowning and squinting result from child's inclination to improve the visual activity by reducing the lid aperture. Concave lenses correct the error.

Astigmatism

It means there is difference in the refractive power of different meridians of the eye, usually because of the irregularity in the curvature of the cornea or lens. As a result, parallel rays of light fail to come to focus at a point. Astigmatism may be complicated by amblyopia.

Significant astigmatism leads to distortion of images, frowning, squinting, eyestrain, headache, fatigue, eye-rubbing, lid hyperemia, indifference to schoolwork, and holding reading matter close.

Conditions predisposing to astigmatism are ocular trauma, periorbital and eyelid hemangioma and ptosis.

Cylindrical or spherocylindrical lenses correct the error.

Anisometropia

Difference in the refractive states of the two eyes may cause amblyopia or "lazy eye". Early correction is warranted.

Impairment/Paralysis of Accommodation

It may result from premature presbyopia, overuse of cycloplegic substances (anticholinergics, poisons), 3rd cranial nerve lesions, botulism, diphtheria, Wilson disease, diabetes mellitus, syphilis, viral infections, feigning (psychogenic), etc. Congenital inability to accommodate, though rare, is known.

VISUAL DISORDERS

Amblyopia means subnormal vision in one or both eyes in spite of correction of significant refractive error. The

most important cause is sensory stimulation deprivation during the early developmental life (sensory deprivation amblyopia).

Amaurosis means partial or total loss of vision in the form of profound impairment, near-blindness, or blindness. It may follow developmental malformations, gestational/perinatal infections, anoxia/hypoxia, perinatal trauma, and certain genetic disorders. If it develops in a child who once had good vision, the etiologic factors may be an ocular disease, encephalopathy, vasculitis, migraine, leukemia, toxins, trauma, infectious or postinfectious processes, demyelinating diseases, rapidly rising intracranial pressure, dysfunction of a shunt, craniopharyngioma, neurodegenerative disease, tumors, gliomas of optic nerve or chiasm, etc. Accompanying manifestations include strabismus, nystagmus, timidity, clumsiness, behavioral changes, deterioration in school performance and shirking participation in school activities.

Night blindness (nyctalopia) may be congenital or acquired (xerophthalmia, quinine and other retinotoxic drugs, retinal, choroidal or vitrioretinal degeneration).

Diplopia, meaning double vision, usually occurs in strabismus and in proptosis. It may be a warning sign for the ensuing raised ICP, a brain tumor, an orbital mass or myasthenia gravis. Monocular diplopia points to existence of dislocated lens, or a defect in the media or the macule.

Psychogenic vision problems, both malingering and conversion reaction, may be complained of by the schoolgoing children.

Dyslexia means a specific reading disability due to a primary or developmental defect in the higher cortical processing of graphic symbols. The associated symptoms include letter or word reversal and mirror writing. An ophthalmologic evaluation is warranted. Treatment is directed at remedial instruction and counseling of the child and the family.

DISEASES OF THE RETINA AND VITREOUS

Retinopathy of Prematurity (Retrolental Fibroplasia)

Etiopathogenesis

Prematurity (< 33 weeks), retinal immaturity and hyperoxia are the major etiologic factors.

Sickness of the neonate (respiratory distress, apnea, bradycardia, infection, anemia, heart disease, hypoxia, hypercarbia, acidosis, need for transfusion) is a contributory factor.

The first landmark in its pathogenesis is cessation of vasculogenesis. A line marks the abrupt termination of vascularized to the avascular retina. The line changes into a ridge and vascularization of retina may proceed. Or, an abnormal proliferation of vessels out of the plane of the retina into the vitreous, over surface of retina, ciliary body and lens. Finally, cicatrization and traction on retina may cause retinal detachment.

Classification

Five stages of ROP are now recognized (Table 37.4).

Table 37.4: International classification of retinopathy of prematurity (ROP)

Stage I	A demarcation line between the vascularized and avascular retina.
Stage II	A ridge in place of the line.
Stage III	A ridge plus extraretinal fibrovascular tissue.
Stage IV	A subtotal retinal detachment. <i>Phase I</i> when macula is spared. <i>Phase II</i> when macula is involved.
Stage V	Total retinal detachment

Treatment

Early diagnosis followed by cryotherapy to the avascular retina prevents further progression of retinopathy. In advanced cases (stage V), sophisticated vitreoretinal surgery may successfully reattach the retina.

Prevention

This lies in prevention of prematurity, judicious use of oxygen, and supplemental vitamin E as an antioxidant in high-risk infants.

RETINOBLASTOMA

Refer Chapter 28 (Pediatric Oncology).

Retinitis Pigmentosa

This is a type of progressive retinal degeneration characterized by pigmentary changes, narrowing of retinal arteries, optic atrophy and impaired visual function.

It may be primary or secondary to intrauterine infections (TORCH, STORCH), mucopolysaccharidosis, late-onset gangliosidosis, abetalipoproteinemia, progressive retinal ophthalmoplegia, drugs (Chloroquine, phenothiazines), Laurence-Moon-Biedl syndrome, Usher syndrome, Refsum syndrome, hereditary ataxia and Alport syndrome.

Manifestations include difficulty in dark adaptation, progressive loss of peripheral followed by central vision, and reduced retinal function as measured by electroretinography.

Retinal Detachment

It means separation of outer layer of retina from the underlying retinal pigment epithelium. It may be primary or secondary.

Secondary retinal detachment is of three types. Rhegmatogenous detachment (trauma as in child abuse, myopia, ROP, congenital cataract surgery) is the result of a break in the retina that allows fluid to enter the subretinal space. Tractional detachment (diabetes mellitus, sickle-cell disease, retinopathy) follows pull of the vitreoretinal membrane on the retina. Exudative detachment (retinoblastoma, ocular inflammation, Coats' disease) results from exudation exceeding absorption.

Manifestations include loss of vision, strabismus, nystagmus, white pupillary reflex (leukocoria).

Diagnosis is established by ultrasonography, CT scan, and MRI.

Hypertensive Retinopathy

Detection of hypertensive retinal changes is a clue to existence of renal disease, pheochromocytoma, cardiovascular disease (coarctation of aorta in particular) or collagen disorder.

Diabetic Retinopathy

Early (nonproliferative) diabetic retinopathy is characterized by microaneurysms, venous dilation and hemorrhages and exudates.

Late or more advanced (proliferative) diabetic retinopathy is characterized by neovascularization and proliferation of fibrovascular tissue extending on to the vitreous and vision-threatening complications like vitreous hemorrhages, cicatrization, traction, and retinal detachment, and rubeosis of the iris and secondary glaucoma.

It occurs in only 20 to 25% diabetic children before 10 years and in as high as 50 to 60% after 20 years of known disease.

Adequate control of the diabetic state helps in postponing diabetic retinopathy. Ocular therapy in the form of retinal photocoagulation and vitrectomy contributes to reduce morbidity.

OPTIC NERVE DISEASES (Figs 37.5 to 37.9)

Papilledema (*Choked Disk*)

The term denotes the noninflammatory passive edema of the optic disk secondary to increased intracranial pressure (ICP) from such causes as intracranial space-occupying lesion (ICSOL) like tumors, obstructive hydrocephalus, intracranial hemorrhage, meningoencephalitis, toxic encephalopathy, conditions with early closure of sutures and fontanel (craniosynostosis) and pseudotumor cerebri.

The disc changes include edematous blurring of the disk margins, fullness of the nerve head, partial or complete obliteration of the physiologic cup, capillary congestion and hyperemia of the nerve head, generalized engorgement of the veins, loss of spontaneous venous pulsation, nerve fiber layer hemorrhages around the disk and peripapillary exudates. Additional features in some cases include extension of edema onto the macula leading to star-shaped or fanshaped figure formation, and concentric peripapillary retinal wrinkling.

Though papilledema resolves following relief of raised ICP, disk takes 6 to 8 weeks to revert to normal. Long-standing papilledema accompanying chronic raised ICP may cause permanent nerve fiber damage, atrophic changes of the disk, nuclear scarring and impairment of vision.

Lumbar puncture in the presence of papilledema must only be done by an expert. Else, it may cause "coning" and death.

Optic Neuritis

The term is applied to inflammation, demyelination or degeneration of the optic nerve with impairment of its function.

When optic neuritis restricts to retrobulbar portion of the nerve without any changes in the fundus, it is termed *retrobulbar neuritis*.

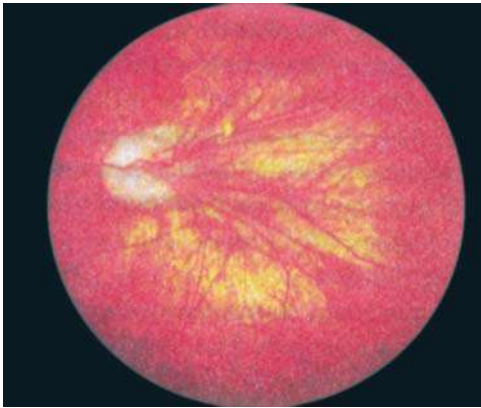

Fig. 37.5: Fundus in ROP. Note beginning of vascular traction of the optic disk towards the temporal periphery

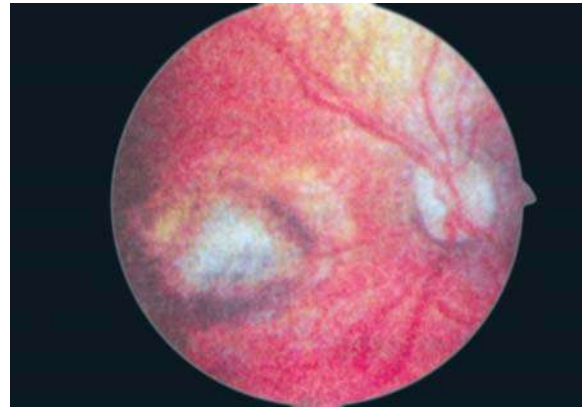

Fig. 37.8: Fundus in congenital toxoplasmosis. Note the large atrophied area of macula with abundant pigmentation at the edges suggesting choroidoretinitis

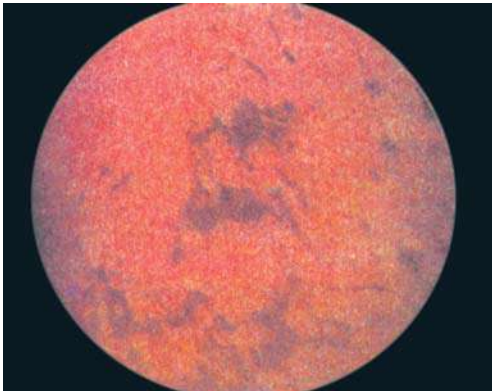

Fig. 37.6: Fundus in ROP. Note the remarkable pigment changes

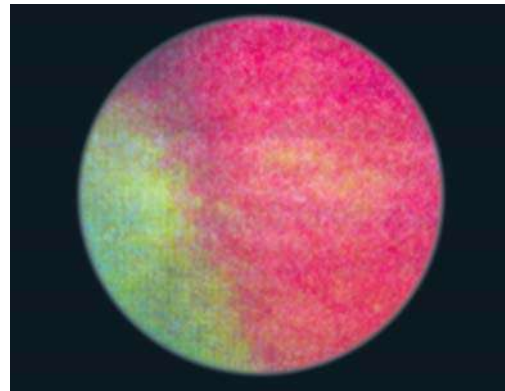

Fig. 37.9: Fundus in ROP. Note fibrovascular proliferation on the margin of retina in the region of temporal periphery

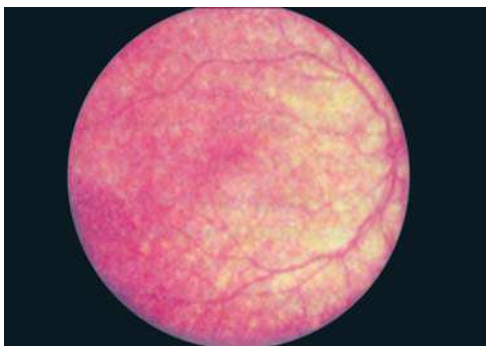

Fig. 37.7: Fundus in congenital rubella. Note finely dispersed dark and light pigmentation, especially in the region of the posterior pole

When the changes are detectable at the fundus ophthalmoscopically, it is termed *papillitis* (intraocular optic neuritis).

When involvement is of both of retina and papilla, it is termed *optic neuroretinitis*.

The etiologic factors include bacterial meningitis, encephalomyelitis following an exanthem, demyelinating diseases, drugs/toxins (chloramphenicol, vincristine, ethambutol, phenothiazines, quinidine, lead).

Treatment is with high doses of systemic steroids. Most cases begin to respond in 1 to 4 weeks, the vision reverting to normal in weeks or months. Permanent impairment of vision may occur in some instances.

Optic Atrophy

This refers to irreversible degeneration of the optic disc which develops remarkable pallor with reduction in number of capillaries below 7 against the normal 10 or more, and the loss of substance of the nerve head.

Primary optic atrophy denotes occurrence of atrophy without previous ophthalmoscopic evidence of

papilledema/papillitis. It follows involvement of neurons proximal to the disk. Disk margins are well defined.

Secondary optic atrophy denotes occurrence of atrophy with previous evidence of papilledema/papillitis. It involves the choked disk. Disk margins are poorly defined.

Etiologic factors include intracranial tumors and traumatic, inflammatory, vascular, and degenerative disorders. At times, progressive optic atrophy is hereditary.

SYSTEMIC MEDICATION AND OCULAR DAMAGE

In this connection, two drugs need a special mention.

Chloramphenicol, when consumed over a prolonged period, may cause optic neuritis, most often retrobulbar neuritis. Withdrawal of the drug usually leads to complete recovery.

Corticosteroids may cause two problems, namely:

- *Subcapsular cataract*, following high doses, say 15-20 mg of prednisone daily over a span of 2 years or so.
- *Glaucoma* (secondary in susceptible children).

OCULAR TRAUMA

- A simple blunt trauma may cause just what is termed *black eye*.
- A *penetrating injury* can be dangerous.
- A detailed history from parents/attendants is important. It is advisable that the pediatrician seeks assistance from an ophthalmologist who may prefer to examine the child in operation theater under mild sedation to ascertain the nature and extent of the damage to the ocular structures.

FURTHER READING

Articles/Chapters

1. Ghose S, Kalra BR. Red eye: A common problem in children. *Indian J Pediatr* 1982;49:751-759.
2. Olitsky SB, Nelson LB. Disorders of the eye. In Behrman RE, Kliegman RM, Jenson HB (Eds): *Nelson Textbook of Pediatrics*, 18th edn. Philadelphia: Saunders 2004;2083-2124.

Books/Monographs

1. Harley RD. *Pediatric Ophthalmology*. Philadelphia: Saunders 1975.
2. Nema HV: *Textbook of Ophthalmology*, (2nd edn). New Delhi: Jaypee 1991.

CHAPTER



Pediatric Ear, Nose and Throat (ENT) Problems

Aniece Chowdhary, Suraj Gupte

INTRODUCTION

Almost 1/3rd of ENT OPD attendance is accounted by the pediatric subjects. In pediatrics *per se*, around 1/5th of the problems are accounted by the ENT disorders. The reasons for this high incidence of ENT problems in pediatric age group include:

- Infections which easily attack immature immune system, anatomy and physiology.
- Shorter, straighter eustachian tube with inadequate opening mechanism in the child than the adult.
- Lymphoid hypertrophy.

THE EAR DISORDERS

The complicated embryology of ear allows for a large variety of developmental malformations of pinna, external meatus, tympanic membrane, middle ear cavity and ossicles. From the point of view of congenital conductive deafness, defects in the external meatus (which prevent sound waves reaching the tympanic membrane) and abnormalities of ossicular chain (which interfere with transmission of sound to inner ear) are most important.

Congenital malformations include accessory skin tags (preauricular tags or pits may be part of such syndromes as Goldenhar, Cri du chat, Wolf or Trisomy 4p), "lop" ear (abnormally prominent ear), auricle that is rudimentary (microtia) or totally absent (anotia), atresia or stenosis of the external auditory canal (usually with sensorineural hearing loss), congenital cholesteatoma which acts as a tumor and a focus of severe infection.

Acquired disorders include otitis externa, furunculosis, acute cellulitis, dermatoses, herpes simplex, herpes zoster oticus (Rasmay-Hunt syndrome) and bullous myringitis, wax, and otitis media.

Otitis externa (swimmer's ear) is characterized by diffusely red and swollen ear canal, resulting in earache accentuated by manipulation of pinna and pressure on the tragus. The common etiologic agents are *Ps. aeruginosa*, *Ps. sp*, *Ent. aerogenes*, *Prot. mirabilis*, *Kl. pneumoniae*, *S. epidermidis*, *Candida* and *Aspergillus*.

Treatment consists in instillation of antibiotic plus steroid drops in most cases.

Wax (cerumen) is a product of glandular secretions and exfoliated keratin. If in excess, when it may block the canal at any age, its removal can usually be accomplished by softening drops, syringing, mechanical means, or a combination of these.

Foreign Bodies in the Ear

Nonliving foreign bodies often inserted into the external auditory canal include pieces of paper, chalk, or eraser, grain seeds which tend to swell with passage of time and get tightly impacted.

Living foreign bodies (say insects) may find their way into the ear canal and cause intense irritation and pain. Before its removal, the insect needs to be killed by instilling spirit or chloroform water.

The foreign body may be removed carefully by forceps, syringing, suction, special instruments or post-aural approach, depending on the merits of the case.

Acute Otitis Media

The term refers to the infection of the middle ear. It is particularly common in infants and young children. First, because the eustachian tube is short, wide and horizontal and the baby tends to lie supine, thereby hindering the drainage. Secondly, upper respiratory infections are quite frequent and result in obstruction by the lymphoid tissue in this age groups. Thirdly, congestion of the gums in babies who are erupting teeth may cause spread of infection through the lymphatics of the eustachian tube to the middle ear.

Etiology

The common etiologic organisms in order of frequency are *S. pneumoniae*, *H. influenzae* and *Moraxella catarrhalis* (these three are responsible for 75% of the cases), *S. aureus*, group A *Streptococcus*, Alpha *Streptococcus*, *P. aeruginosa* and group B *Streptococcus*. In neonates who are hospitalized or who are under 2 weeks, gram-negative pathogens, *S. aureus* and group B *Streptococcus* are most frequent. In a proportion of the cases, viral infection may be the cause.

The condition is usually associated with upper respiratory infection (25% of pediatric URI cases develop it), measles, influenza or rubella.

Clinical Features

Manifestations include pain, restlessness, discharge and fever. Parenteral diarrhea and vomiting may occur.

Ear drum appears lusterless, rough and red initially. Later, collection of pus causes loss of its landmarks and it bulges outwardly (Fig. 38.1). Perforation may occur, resulting in accumulation of pus in the canal.

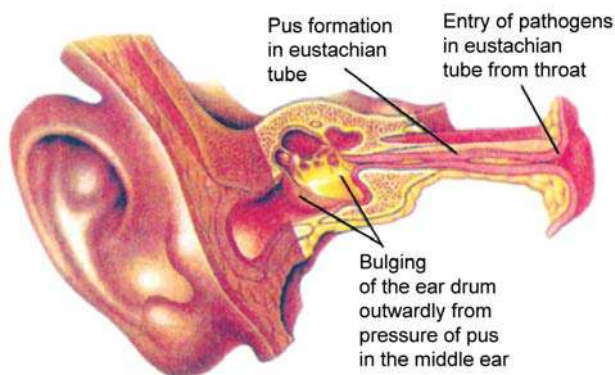

Fig. 38.1: Acute otitis media (an artist's representation)

All infants with unexplained pyrexia and/or screaming should have AOM excluded.

Treatment

Amoxycillin is the drug of choice. In view of high incidence of beta-lactamase-mediated resistance, amoxycillin-clavulanate may be preferred. Alternative recommendations include cefaclor, cefuroxime axetil, ceadroxil, cefixime, erythromycin-sulfa combination, etc. A 10-day to 2-week therapy suffices. A single dose therapy with ceftriaxone (IM) has given equally good results.

Supportive measures include analgesics, decongestants and local heat. If there is considerably bulging of the drum with severe pain that has not responded to conservative measures, the drum may be incised under anesthesia. If the drum has already burst, the ear canal should be swabbed clean and dry repeatedly.

Prognosis

Most cases recover completely. Some may relapse quickly as soon antibiotic is withdrawn. These children often carry a collection of sterile secretions in middle ear between acute attacks and are noted to constantly rub their ears. Treatment comprises of myringotomy and insertion of grommet tubes on a prophylactic basis.

Complications

Complications include, recurrent otitis media, perforation of the drum, acute mastoiditis with or without chronic otitis media, meningitis and cerebral abscess.

The term *otitis media with effusion* refers to the middle ear effusion lacking the clinical manifestations of acute infection like earache and pyrexia. The effusion may be serous, mucoid or purulent. No treatment is usually indicated as in 90% of cases it clears by 3 months after the first episode of otitis media. If the effusion persists beyond 3 months (chronic OME), a trial of antibiotics followed by, if needed, myringotomy with insertion of tympanostomy tubes is indicated.

Chronic otitis media is characterized by perforation of the tympanic membrane with otorrhea and hearing loss (active COM) or only hearing loss (inactive COM).

The first, often termed chronic suppurative otitis media (CSOM), is elimination of the infection from the middle ear and the mastoid followed by surgical repair after the age of 10 years.

Deafness (Hearing Impairment)

Children with profound (>90 dB) loss or total deafness fail to develop speech. They are often labelled “deaf-mute or deaf and dumb. However, they have a normal speech-producing apparatus. Since they have never heard speech, they fail to develop it. In lesser degree of hearing loss, speech develops but is defective. Period from birth to 5 years is critical for development of speech and language. Logically, therefore, early identification and assessment of hearing loss is important.

Hearing loss may be congenital or acquired, temporary or permanent, of varying magnitude (mild, moderate or profound), peripheral or central in origin, and organic or nonorganic.

5 Types

Central hearing deficit denotes auditory deficit originating along central auditory nervous system from the proximal 8th nerve to cortex (seizures, tumors, demyelinating disease. Landau syndrome).

Peripheral hearing deficit denotes dysfunction in the sound transmission through the external or middle ear as also its conversion into neural activity at the inner ear and 8th nerve. It may be *conductive* (impacted wax, foreign body, perforation of tympanic membrane, otitis media with effusion, cholesteatoma, otosclerosis, etc. blocking sound transmission in external and middle ear), *sensorineural* (lesion of acoustic division of 8th nerve, destruction of hair cells in inner ear), or *mixed*.

Etiology

Table 38.1 gives the etiology of hearing loss depending on whether it is congenital or postnatal and genetic or nongenetic.

Table 38.1: Etiology of pediatric deafness

Congenital

Genetic

Familial: Familial deafness (early onset)

Syndromal: Waardenburg syndrome, Pendred syndrome, Usher syndrome, Treacher-Collins syndrome, Pierre Robin syndrome, Crouzon syndrome, Klippel-Feil syndrome

Chromosomal: 13-15 trisomy, 18 trisomy, 21 trisomy,

Nongenetic

Drug teratogenicity: Quinine, streptomycin, thalidomide, irradiation

Intrauterine infections: Rubella, cytomegalovirus

Postnatal

Genetic

Familial: Familial deafness (late onset)

Syndromal: Hunter-Hurler syndrome, von Recklinghausen disease, Alport disease, Alstrom disease

Nongenetic

Mechanical: Blockage of the external auditory meatus

Infections: Meningitis, encephalitis, measles, mumps, syphilis, recurrent otitis media

Drugs: Aminoglycosides, platinum

Toxic: Neonatal hyperbilirubinemia

Brain damage: Cerebral palsy, mental retardation, LBW (under 1500 g), severe respiratory depression prolonged mechanical ventilation

Clinical Effects

Only some 6% of the hearing impaired children have profound hearing loss. The rest retain some hearing. Even mild or unilateral deafness has a detrimental effect on development and performance of the child. Deafness early in life may affect the development of speech, behavior, attention, academic attainment, social development and emotional development.

Evaluation

Identification of hearing impairment is through high index of suspicion (Tables 38.2 and 38.3).

Table 38.2: Signals for hearing loss

- Sleeping though loud noises uninterrupted
- Failure to startle to loud sound
- Failure to develop at 1-2 years
- Defective speech
- Poor school performance

Table 38.3: Risk factors for hearing loss

- Family h/o hearing loss
- Prenatal infections/ototoxic drugs
- Birthweight under 1500 g
- Stigmata of syndromal deafness (deformed pinna, cleft palate, craniofacial anomalies)
- Serum bilirubin exceeding 20 mg/dl in a neonate
- CNS infections (meningitis especially due to *H. influenzae*, encephalitis)
- Hypoxic-ischemic encephalopathy

Assessment of Hearing through Special Techniques

- a. Screening procedures
 1. Arousal test
 2. Audiometry response cradle
- b. Behavior observation audiometry
- c. Distraction techniques
- d. Objective tests
 - Evoked response audiometry
 - Impedance audiometry
 - Otocoustic emissions
 - Heart rate audiometry

Treatment

Evaluation assists in arriving at the type and degree of hearing loss in most of the cases. The objective of treatment is development of speech and language and adjustment in society. Components of treatment are:

1. Parental guidance
2. Hearing aids which help to develop lip reading.
3. Development of speech and language through
 - Auditory oral communication
 - Manual communication
 - Total communication: Use of all modalities of sensory input i.e. auditory, visual, tactile and kinesthetic
 - Education: Radio-hearing aids help the child hear teacher's voice better
 - Vocational guidance.

THE NOSE DISORDERS

Congenital anomalies, usually associated with cleft palate, include choanal atresia which, if bilateral, is a neonatal emergency.

Acquired nose problems include rhinitis, sinusitis, trauma, foreign body, epistaxis.

Acute rhinitis, the commonest disorder of nose, manifests with mucopurulent discharge, often accompanied by sneezing, malaise and headache. It is usually viral but bacterial rhinitis may be severe and accompanied by infection of sinuses, ear or throat. Treatment is with oral and/or local decongestants and analgesics. An antibiotic is indicated if bacterial infection is suspected as judged from its severity and persistence despite symptomatic therapy.

Upper respiratory infections are discussed in Chapter 21 (Pediatric Pulmonology).

Trauma may be followed by nasal obstruction, implying that either deviated nasal septum (DNS) or a septal hematoma has developed.

Foreign Body in Nose

Inanimate foreign bodies found in the nose include beads, buttons, paper, peas, erasers and metal and plastic components of toys. When retained for a long time, they produce granulation tissue.

Animate foreign bodies include maggots, leeches and other insects.

Most often, history clinches the diagnosis. Else, a foul-smelling and blood-stained discharge should arouse suspicion.

For its removal of inanimate foreign body, a curved hook (say, Eustachian catheter) is passed beyond the foreign body which is then pulled out.

Leeches can be removed by putting a pinch of salt or a few drops of oxalic acid on their body. Maggots can be asphyxiated with turpentine oil and then removed as they crawl out for want of oxygen.

Epistaxis (Nosebleeds)

Nosebleeds are common after first year and up to puberty. About 10% of children suffer from this symptom, a vast majority of the bleeds being minor and transient, stopping spontaneously *or with* little pressure.

Location of epistaxis usually is the anterior inferior part of the cartilaginous nasal septum with rich blood supply (Kiesselbach plexus, area or triangle) followed by mucosa lining the anterior portion of the turbinates.

Etiology

Etiologic factors include trauma (nose picking being the most common cause of epistaxis in childhood), upper respiratory infection/allergy, physical and emotional stress and strain (forceful cough, sneezing, exertion, excitement), foreign body, solar radiation, polyp, congenital vascular defects (telangiectasias, varicosities), systemic disease (hypertension, uremia, cirrhosis, nephritis, rheumatic fever, enteric fever) and bleeding disorders (leukemias, purpuras, DIC).

Tuberculosis, syphilis, leprosy, fungal infections, tumors, puberty (menarche), high altitude, scurvy, vitamin K deficiency, sickle-cell disease, brucellosis, etc. may also be accompanied by nosebleeds.

Treatment

Isolated episodes of nosebleeds, especially when minor and restricted to the anterior nares, do not need any diagnostic evaluation.

For severe and repeated episodes originating from posterior nares, especially in association with bleeding from other sites, a complete ENT and hematologic workup is indicated to find out the primary cause of bleeding.

First-aid measure for stopping bleeding consists in compressing the nares with two fingers with the head tilted forward.

If this maneuver fails, local application of epinephrine, 1 in 1,000 solution, preferably with thrombin, is indicated.

Nasal packing (anterior, or combined anterior and posterior) may be needed in some cases.

Cauterization with silver nitrate of the bleeding site to prevent further bleeding may be done after the bleeding has stopped.

Blood transfusion may be indicated in certain subjects with severe or recurrent epistaxis.

Sinusitis

Frontal sinus begins to grow after birth as nasofrontal ducts whereas maxillary, ethmoidal and sphenoidal sinuses are present right at birth. As the primary and secondary teeth move towards alveolar margin, maxillary sinuses grow into the body of maxilla. After 6th year, floor of antrum lies at the level of the floor of nasal cavity.

Acute purulent sinusitis may occur either secondary to acute rhinitis or as an acute empyema. *S. pneumoniae*, *M. catarrhalis*, and *H. influenzae* are the usual etiologic agents.

Manifestations include severe or prolonged "cold", pyrexia, headache, facial pain, daytime cough and tenderness over the sinuses. Postnatal discharge may cause sore throat or a persistent cough at night. Periorbital cellulitis points to involvement of ethmoid sinuses. Complications include periorbital or orbital cellulitis, cavernous sinus thrombosis, meningitis, optic neuritis, subdural abscess and osteomyelitis.

Diagnosis is by demonstration of air-fluid levels and complete opacification and a mucosal width of 4 mm or more on X-ray/CT scan.

Treatment is with an effective antibiotic therapy (amoxicillin as such or in combination with potassium clavulanate in case of beta-lactamase producing organisms, cephalosporins, cotrimoxazole, erythromycin, etc.).

Chronic sinusitis suggests existence of a predisposing disorder such as DNS, polyps, adenoids, septic tooth, allergy, cystic fibrosis, dyskinetic cilia or an immunodeficiency state. *Alpha-hemolytic streptococci*, *S. aureus* and *anaerobes* plus the organisms responsible for acute sinusitis are the causative agents. Manifestations include persistent or recurrent attacks of nasal and postnasal discharge, low-grade fever, malaise, anorexia and easy fatigability. When it occurs in association with lower respiratory tract disease, the term, *sinusbronchitis*, may be employed. All complications of acute sinusitis may also occur in chronic sinusitis.

Radiography, especially a lateral view of the nasopharynx, should always be done in suspected sinusitis. An opacity from sinusitis is far more dense than that seen in restricted air entry into sinuses due to swelling of nasal mucous membrane. A fluid level in a sinus is diagnostic.

In the presence of radiographic evidence of sinus disease, aspiration proof puncture is performed. If mucus is obtained, it should be sent for culture and sensitivity.

Treatment is directed at administering suitable antibiotics for up to 6 weeks plus nasal drops of oxymetazoline HCl (0.05%, 0.025%) which are best

administered by laying the child flat on his back with his head hanging over the side.

Radical sinus surgery is usually not required in children.

Nasal Polyps

The benign pedunculated tumors from chronically inflamed and edematous mucosa, manifest with nasal obstruction, hyponasal phonation, mouth breathing, mucoid or mucopurulent rhinorrhea and widening of the bridge of the nose. Their association with cystic fibrosis (CF), asthma, chronic sinusitis, and chronic allergic rhinitis is well known. Treatment is surgical removal.

THE THROAT DISORDERS

Congenital anomalies include cleft palate and laryngomalacia, laryngeal webs, cysts and hemangiomas.

Acquired disorders include pharyngitis, tonsillitis, adenoids, laryngitis, epiglottitis, etc.

Acute Pharyngitis

The term applies to conditions in which principal involvement is of throat. Tonsillitis and pharyngotonsillitis are covered under this caption.

It usually occurs after first year of life.

Etiology

Viruses and group A beta-hemolytic streptococci are responsible for virtually all cases of acute pharyngitis.

Clinical Features

Viral pharyngitis is characterized by fever, malaise and anorexia followed in a day or so by sore throat, hoarseness, cough and rhinitis. Throat examination reveals slight to intense inflammation with exudates and small ulcers over posterior pharyngeal wall, tonsils, soft palate and lymphoid follicles of palate. Lymphadenopathy and laryngeal involvement are common.

Streptococcal pharyngitis is characterized by such complaints as headache, vomiting, abdominal discomfort and fever followed within hours by intense sore throat and mild to severe dysphagia. Throat examination shows diffuse congestion of the tonsils and its pillars with petechiae over the soft palate. Anterior cervical lymphadenopathy is common.

Diagnosis

Clinical diagnosis may be confirmed by culture of the throat swab or by rapid detection method for streptococcal antigens.

Differential diagnosis is from diphtheria, infectious mononucleosis, herpangina, agranulocytosis, tobacco and marijuana smoking, allergic rhinitis with postnasal drip, gonococcal pharyngitis and pharyngoconjunctival fever.

Complications

Viral pharyngitis may cause the following complications:

- Purulent bacterial otitis media
- Large chronic ulcers in the pharynx in debilitated children
- Mesenteric adenitis

Streptococcal pharyngitis may cause the following complications:

- Large chronic ulcers in the throat
- Sinusitis
- Otitis media
- Chronic ulcers in the pharynx
- Acute glomerulonephritis
- Rheumatic fever
- Meningitis
- Mesenteric adenitis.

Treatment

Streptococcal pharyngitis shows dramatic response to penicillin (oral is good enough), erythromycin or amoxicillin for 10 to 14 days. Once daily amoxicillin therapy has been found to be quite effective in group A beta-hemolytic streptococcal pharyngitis.

Symptomatic measures include analgesics/antipyretics/anti-inflammatory agents, bed-rest as far as possible, warm saline gargles, steam inhalation, etc.

A carrier state is an indication for another course of penicillin plus rifampicin 20 mg/kg once daily for 4 days towards the end of the penicillin course.

Antibiotic prophylaxis against streptococcal disease is indicated in only a small proportion of cases.

Tonsillitis

Acute tonsillitis is discussed under "acute pharyngitis" (see above).

Chronic tonsillitis is characterized by recurrent or persistent sore throat, swallowing and breathing difficulties, sense of dryness and irritation in throat, offensive breathing, and rarely, dyspnea, chronic hypoxemia and pulmonary hypertension.

The problems usually regress in the subsequent years without any specific treatment. Tonsillectomy is, therefore, usually not necessary.

The only definite indication for tonsillectomy are:

1. Peritonsillar abscess (quinsy), and
2. Retrotonsillar abscess.

Occurrence of one or more of the following complications following tonsillectomy in some 10% of the children is also a good reason against unnecessary and avoidable surgery.

1. Minor hemorrhage
2. Postoperative throat infection
3. Anesthetic complications
4. Pulmonary edema.

Adenoids (*Adenoidal Hypertrophy; Hypertrophy of Pharyngeal Tonsils*)

5 Like tonsils, the adenoids are part of the lymph tissues that circle the pharynx (Waldeyer ring) and are susceptible to infection and hypertrophy to such a magnitude that almost the whole vault of nasopharynx may be filled.

Clinical Features

Adenoidal hypertrophy may interfere with the passage of air through the nose, resulting in mouth-breathing (more so when the child lies supine during sleep).

With development of gross adenoidal hypertrophy, the child tends to keep the mouth open during day time as well.

Accompanying manifestations include dryness of mouth and lips, persistent rhinitis, pharyngitis, snoring, nasal voice, offensive breath, impaired taste, bad smell, harassing cough, impaired hearing and chronic otitis media. Eventually, the child develops dull expression with open mouth and maloccluded teeth (*adenoid facies*). School performance suffers.

In a few cases, respiratory insufficiency may cause apneic spells, leading to arterial hypertension and, eventually, cor pulmonale.

Diagnosis

Clinical impression of adenosis needs to be confirmed by digital palpation during the first few years of life. Later, indirect visualization with a pharyngeal mirror or fiberoptic bronchoscope, or a lateral pharyngeal X-ray may help in confirming the diagnosis.

Treatment

Adenoidectomy leads to significant relief and in improvement of child's condition.

Stridor

The term denotes noisy breathing resulting from obstruction to the free flow of air through the larynx or trachea.

In *supraglottic stridor*, the noise is inspiratory and characterized by a low pitch flutter. Voice may remain normal.

In *glottic stridor*, noise is inspiratory and expiratory, exhibiting a phonatory quality. Dyspnea is present.

In *subglottic stridor*, noise is mainly expiratory. Brassy, barking cough is characteristic. Voice may remain normal.

Etiology of stridor is summarized in Table 38.4. In an overwhelming majority (75%) of infants with stridor, the cause is laryngomalacia (*vide infra*).

Laryngomalacia refers to congenital thickness and flabiness of structures surrounding the laryngeal aperture, particularly the aryepiglottic folds. During inspiration, they collapse into the laryngeal inlet, causing narrowing and inspiratory noise.

Table 38.4: Causes of stridor

<i>Congenital:</i>	Pierre Robin syndrome, laryngomalacia, laryngeal web, stenosis, papilloma, vascular ring, tracheoesophageal fistula, cystic hygroma, retrosternal goiter.
<i>Infection:</i>	Laryngitis, epiglottitis, laryngotracheobronchitis, diphtheria, peritonsillar or retropharyngeal abscess.
<i>Trauma:</i>	Intubation, inhalation burn.
<i>Mechanical:</i>	Foreign body, enlarged tonsils and adenoids, cysts or tumors of vocal cord, goiter,
<i>Vocal cord paralysis:</i>	Local—Birth trauma, PDA.
<i>Nutritional:</i>	Central—Cerebral palsy, hydrocephalus.
<i>Allergic:</i>	Tetany Angioneurotic edema.

It manifests as inspiratory stridor within a few weeks of birth. The stridor becomes more pronounced on crying or when the infant lies supine (i.e. on his back).

Direct laryngoscopy shows indrawing of the aryepiglottic folds. When laryngoscopy is passed in between these folds, stridor disappears.

Treatment revolves around reassurance. It gradually decreases in severity, usually subsiding by 6-12 months age. Often, it may persist for 2-3 years.

Croup (*Acute Laryngotracheobronchitis*)

Croup refers to inflammation of the larynx, characterized by croaking cough, stridor, hoarseness, cold, and fever. With increasing dyspnea, cyanosis and restlessness develop.

Generally, it is due to infection with *Hemophilus influenzae* or parainfluenzae/respiratory syncytial virus. Apparently the condition seems quite alarming. Fortunately, in a large majority of the cases, it resolves well. It may, however, spread lower down leading to laryngotracheobronchitis.

Differential diagnosis is primarily from diphtheria, foreign body, angioneurotic edema, and retropharyngeal abscess.

Treatment consists in administering oxygen and appropriate antibiotic cover in humidified room or by face mask together with the symptomatic measures depending on the merits of the case. Since some subjects may require tracheostomy, it is advisable to hospitalize the patient, especially if there is much respiratory distress.

Racemic epinephrine (0.5 ml of 2% solution diluted with sterile water to a total volume of 3.5 ml), delivered by a face mask by intermittent positive pressure breathing for 15 minutes, has now emerged as an effective therapy. This therapy may be of benefit in patients ill enough to need hospitalization. It is claimed to reduce the necessity of subsequent tracheostomy, to reduce subglottic edema and potentiate effect of racemic epinephrine.

The role of steroids in its management is doubtful.

Acute Epiglottitis

It is a rare disease seen in children of 3-6 year age group. In most cases, the causative pathogen is *Hemophilus influenzae type B* (HIB).

Manifestations include sore throat and dysphagia which soon progress to marked respiratory distress, prostration and even shock.

In order to relieve the obstruction causing respiratory difficulty, tracheostomy is warranted. Steroids may be of help. For HIB infection, ampicillin is the drug of choice.

DIPHTHERIA

Refer Chapter 19 (Pediatric Bacterial Infections).

INTUBATION AND TRACHEOSTOMY

Intubation and tracheostomy are performed for relieving the airway obstruction, facilitating bronchial toilet and assisting ventilation so that respiratory distress is either prevented or overcome. Table 38.5 gives indications for intubation and tracheostomy.

Table 38.5: Indications for intubation and tracheostomy

Bronchial Toilet

Respiratory Distress

Acute obstruction in the region of larynx: Acute epiglottitis, foreign body

Acute lower respiratory tract infection: Acute laryngotracheobronchitis, bronchitis, Staphylococcal, pneumonia

Edema from inflammatory causes

Intubation is preferred if the natural course of disease is expected to be short, usually when the cause of obstruction lies in the neighborhood of larynx. Intubation tubes are either of polyvinyl or silastic material. Silastic tubes are preferred as they are inert and cause very little tissue damage and become malleable at body temperature, thereby conforming to various contours they traverse. Usually no sedation is required.

Tracheostomy is the procedure of choice for relief of airway obstruction when intubation is not workable or when such relief is required for periods extending the safe upper limit of intubation. Usually it is performed under general anesthesia. The incision made is a short transverse one midway between lower border of thyroid cartilage and suprasternal notch.

The child with tracheostomy should be nursed in an atmosphere of moist air because warming and moistening functions of nasal mucosa have been bypassed.

Complications of tracheostomy include:

- Subcutaneous emphysema from a leak around tube
- Mediastinal emphysema and pneumothorax due to exit of the tube from trachea or extensive dissection in lower neck
- Death due to complication of operation, blockage of tube, crusts in bronchi, duplication of tube and improperly inserted tube.

In case of a tracheostomy performed for an acute condition, extubation is done within a week. In case of tracheostomy which has been there for quite sometime, intubation should be done after a soft tissue lateral radiograph to ensure that alignment of airway is not distorted.

FURTHER READING

Articles/Chapters

1. Deka SK. Otitis media. In Gupte S (Ed): *Recent Advances in Pediatrics-8*. New Delhi: Jaypee 1998.
2. Haddal J Jr. Hearing loss. In Kliegman RM, Behrman EA, Jenson HB, Stanton (Eds): *Nelson Textbook of Pediatrics*, (18th edn). Philadelphia: Saunders 2008;2129-2134.
2. Kacker SK, Kumar S. Pediatric otolaryngology. In Gupte S (Ed): *Recent Advances in Pediatrics-4*. New Delhi: Jaypee 1994:324-336.

Book/Monograph

1. Dhingra PL. *Diseases of Ear, Nose and Throat*. New Delhi: BI Churchill Livingstone 1997.



Pediatric Dental Problems

NK Nagpal, Suraj Gupte

NORMAL DENTITION

Initiation of primary dentition occurs *in utero* round about 7th week of gestation when primary teeth take root in dental crypts, the latter arising from a band of epithelial cells incorporated into each developing jaw. Tooth formation in case of permanent teeth begins around 15th week of intrauterine life, the incisors being the first ones to appear followed by molars.

After the formation of matrix, it takes another two months for the commencement of calcification. The color, texture or thickness of the tooth surface may be influenced by disturbance of matrix formation, under- or nonavailability of one of the minerals involved, or the incorporation of foreign materials.

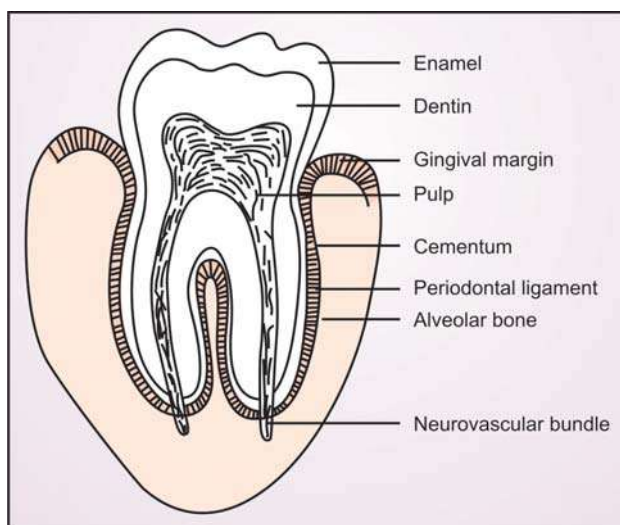

Fig. 39.1: Diagrammatic representation of the structure of the normal tooth

For time of eruption of primary and permanent teeth and anomalies of development, see Chapter 3 (Growth and Development).

DENTAL MALOCCLUSION

The term, *malocclusion*, implies malposition and imperfect contact of the mandibular and maxillary teeth. Lack of proper relationship between upper and lower dental arches result in:

1. Cosmetic disfigurement of the face
2. Erroneous mastication
3. Loss of teeth as the masticating/biting force is distributed from bone to tooth attachment over a much smaller area when the teeth of the upper jaw and the lower jaw fail to meet simultaneously.

Normally, the teeth of the upper jaw are in a position just inside those of the lower jaw. This contributes to a state when the outside mandibular cusps (incisal edges) meet the central portion of the opposing maxillary teeth. If this relation is reversed, the condition is termed *cross bite*.

In another situation, the posterior mandibular and opposing maxillary teeth make good contact with each other. However, the anterior teeth of the two jaws are still apart. This is termed *open bite*.

In yet another situation, the posterior teeth of the two jaws are together but the mandibular anterior teeth occlude inside the maxillary anterior teeth in an overclosed position. This situation is termed *closed bite*.

Ideally, moderate spacing of primary incisors is desirable so that the subsequent teeth are adequately aligned. If there is lack of spacing between primary

incisors, or these show overlap, *dental crowding* involving the permanent incisors at 7 or 8 years of age is likely to result.

Thumb-sucking when vigorous may cause an “open bite”.

If it continues beyond the time of eruption of permanent teeth, maxillary arch and the incisor teeth may well be distorted.

Malocclusion requires orthodontic treatment, including bracing.

DENTAL CARIES

The term refers to a progressive dental decay comprising decalcification of the enamel and dentin, resulting in formation of a cavity that, if left untreated, spreads into the pulp and gives way to inflammation and abscess.

Etiopathogenesis

Three cardinal factors and the interrelationship between them play major role in causation of dental caries. These factors are:

1. Tooth surface,
2. Dietary carbohydrates and sugars, primarily sucrose, and
3. Specific oral bacteria.

The decay process starts following demineralization of the outer tooth surface (enamel) from the effect of organic acids produced by the bacterial fermentation of dietary carbohydrates. Incipient lesions first make their appearance as opaque white spots. With progress loss of dentine, cavitation occurs. The cavity, if not treated, spreads into the pulp. This may cause inflammation and an abscess. At this stage, it becomes very difficult to save the tooth.

The cariogenic microorganisms, grouped as *Streptococcus mutans*, are believed to initiate most dental caries of enamel surfaces. The *Lactobacillus* and other oral bacteria invade the underlying dentin after the enamel surface has cavitated, causing further destruction through a mixed bacterial infection.

A noteworthy point is that, rather than the quantity of carbohydrates consumed, frequency and the longevity of retention in the oral cavity is more important for the cariogenic effect.

High-risk conditions for dental caries include faulty salivary gland function (drugs that cause xerostomia,

Sjögren syndrome, Mikulicz disease, chronic graft-versus-host disease), GER, bulimia, rumination, mental retardation, Prader-Willi syndrome, dystrophic epidermolysis bullosa, sleeping with the feeding bottle, very high frequency breastfeeding, use of dummy or pacifiers which have honey or some other sweetening agents, etc.

Clinical Features

Early dental caries are, as a rule asymptomatic. These begin in the pits and fissures of biting surfaces of the molars. These are detected by the dentist by probing. The pit and fissure caries of long duration, can easily be detected as extensive cavities.

The second commonest site of caries is contact surfaces between teeth. It is usually detected by intraoral X-rays.

Caries involving necks of the teeth is uncommon in children, except those with *nursing bottle caries* (NBC), also termed baby bottle tooth decay (BBTD).

Significant toothache occurs when the dental caries spread to involve the pulp and contiguous tissues. Pulpitis may be complicated by dental/periapical abscess which is very painful (Fig. 39.2). Sepsis may complicate the picture.



Fig. 39.2: Nursing bottle caries (NBC). Involvement of the neck of the tooth is the characteristic feature of NBC, also termed “baby bottle tooth decay” (BBTD)

Treatment

Pain and inflammation with caries involving only the dentoalveolar unit needs analgesic (paracetamol or a NSAID) together with local measures like extraction, pulpectomy, etc. minus antibiotics.

Pain and inflammation from caries involving structures outside the dentoalveolar unit, antibiotics must routinely be administered.

Parenteral antibiotics are indicated in the following situations:

1. Infection involving vital area such as submandibular space, facial triangle, periorbital space.
2. Oral antibiotics are not effective.
3. Susceptibility to endocarditis.
4. Immunocompromized status.

Prevention

1. *Fluoride* It protects the tooth enamel from decay. Fluoridation of water supply dietary, fluoride supplements and topical application of fluoride agents either professionally or by the child (fluoride toothpaste) are beneficial in prevention of caries.
2. *Dietary modification* Reducing the frequency of carbohydrate ingestion, avoiding oral retaining of carbohydrate-containing food products (chewing gum containing sucrose) for a long time, and discouraging bottle feeding and use of dummies (pacifiers) prevents dental caries.
3. *Oral hygiene* Correct tooth brushing and flossing (even though it needs greater parental involvement) is vital in caries prevention.
4. *Dental sealants and plastics* Development pits and fissures on occlusal surfaces of teeth should be sealed by the application of photocured bis-GMA resin film for preventing caries.
5. *Identification of high-risk children* Appropriate preventive measure can safeguard against caries in them.

FLUOROSIS

The caries preventive role of fluoride is well established. Nevertheless, high serum levels of fluoride (usually from drinking water or toothpaste having very high content of fluoride) may cause high serum levels of fluoride. The result is developmental

anomalies of enamel in the form of white flecking or linear opacity of the enamel. This condition is termed fluorosis. The disease is rampant in several parts of India where drinking water contains over 2 parts/million of fluoride. Extradental manifestations of fluorosis such as involvement of the vertebral column and spinal cord with paraplegia take decades to manifest.

GUIDELINES FOR PREVENTION OF DENTAL DISEASE

Dental/Oral Hygiene

Good orodental hygiene, involving cleanliness after each and every meal and correct brushing, ensure removal of the food particles that may form focal points for tooth decay, contribute to healthy teeth. Application of the fissure “sealants” is found highly effective in safe-guarding against dental caries.

Diet

Added sugars in the form of sweet drinks, biscuits, cakes, candies, sweets, etc. especially when consumed frequently, are the main culprit for dental caries. The practice of consuming these substances frequently must be cut down and proper cleansing of the teeth of their intake ensured.

Fluoride and Fluoridation

In areas where fluoride content of water is inadequate (under 1 part/million or 1 mg/l) and fluoridation of water is yet not done, the following measures may be adopted.

- Self application through use of fluoride toothpaste, making sure that young children are not exposed to excessive consumption.
- Topical application of fluoride solution or gel by the dentist.
- Fluoride tablets or drops given from an early age so that both temporary and permanent teeth are protected.
- Fluoridized salt.

Regular Dental Check-ups

Regular and frequent dental check-ups, which may involve professional cleaning, removal of plaques and polishing contributes to prevention of dental disease.

CLEFT LIP AND PALATE (Figs 39.3 to 39.6)

Cleft lip may be unilateral or bilatera, the extent varying from a notch in the vermilion border to a large cleft reaching the floor of the nose. Accompanying anomalies include cleft palate, and supernumerary, deformed or absent teeth.

Cleft palate, when occurring in isolation, is in the midline. It involves only the uvula or reaches the incisive foramen through soft palate. When occurring in association with cleft lip, it involves the

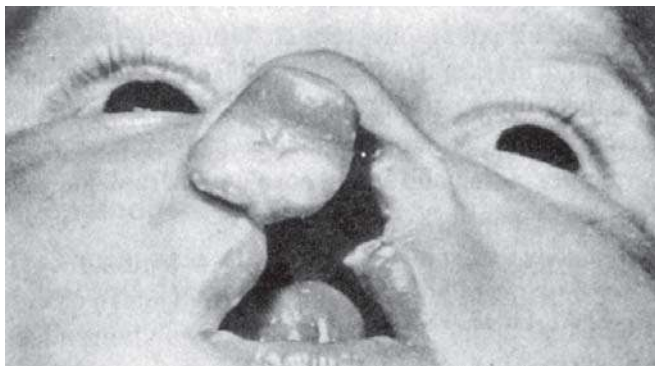

Fig. 39.3: Advanced dental caries in a child with thalassemia major



Fig. 39.5: Cleft lip and palate. Note the accompanying umbilical hernia



Fig. 39.6: Bilateral cleft lip and cleft palate



Fig. 39.4: Cleft lip (unilateral) extending into the right nostril

soft palate and exposes the nasal cavity on one or both sides depending upon whether the defect is unilateral or bilateral.

Complications include aspiration, recurrent otitis media, dental caries, dental malocclusion, and speech defects.

Treatment is surgical closure at 1 to 2 months for cleft lip and 6 months to 5 years for cleft palate. Pending surgical correction, the baby should be fed in an upright position, employing softened nipples

with somewhat bigger holes, so that aspiration does not occur.

FURTHER READING

Articles/Chapters

1. Gupte S. Feeding bottle caries: Risk factors. *Scientific Abstracts, 8th Asian Congress of Pediatrics* New Delhi, 1994; Abs No FD19/22:141.
2. Singh G, Joshi JL. Dental problems of the handicapped child. In Gupte S (Ed): *Recent Advances in Pediatrics-7*. New Delhi: Jaypee 1997:265-280.

Books/Monographs

1. Sidney BF. *Clinical Pedodontics*. Philadelphia: Saunders 1991.
2. Waterhouse, E. *Pediatric Dentistry*. London: Smith and Smith 2001.



GASTROINTESTINAL PROBLEMS

CONGENITAL HYPERTROPHIC PYLORIC STENOSIS

This classical and common syndrome of obstructing pyloric circular muscular hypertrophy was initially considered to be developmental in origin but now is thought to be acquired. There is some evidence of genetic predisposition and variability among different races. This disorder is certainly more common in western world as compared to India. The incidence is significantly higher in the first male babies.

Clinical Features

The typical presentation is with onset of non-bilious vomiting starting anytime between 1-8 weeks of age and which progressively becomes forceful and "projectile". The peak age of presentation is between 3-5 weeks, though it may occur at birth and has been reported on prenatal ultrasonogram also. In general premature infants present 1-2 weeks later as compared to term infants. The vomiting typically occurs within 30 minutes of feeding and may contain coffee grounds also as a result of gastritis or esophagitis. Other features are constant hunger and failure to thrive.

Occasionally, greenish stools (starvation diarrhea), gastric hemorrhage or jaundice may be present.

Dehydration, electrolyte imbalance—especially metabolic alkalosis, hypokalemia and hyponatremia—and tetanic spasms may complicate the picture.

The important clinical findings include epigastric fullness, gastric waves moving from left to right and a

palpable lump (olive-shaped) in the right upper quadrant. The palpation of lump requires diligence and clinical skill. The use of a pacifier or a small feed, covering the infant and examining while in mother's lap are all helpful maneuvers. Failure to palpate pylorus necessitates further work-up to rule out severe gastroesophageal reflux, antropyloric webs, pyloric atresia and duplication anomalies.

Diagnosis

Clinical impression is confirmed by ultrasound and, if still in doubt, by a barium meal study. On ultrasonogram—pyloric channel longer than 16 mm, pyloric muscle thickness more than 4 mm and pyloric diameter more than 14 mm are considered to be diagnostic. On barium study the stomach is markedly distended with abnormal retention of barium, and there is increased intensity of peristaltic waves and gross narrowing and elongation of pylorus with indentation of antral outline by hypertrophied pyloric muscle (Fig. 40.1).

Treatment

The treatment of choice is surgical division of hypertrophied muscle bundles of pylorus (*Ramstedt pyloromyotomy*). But before resorting to surgery, infant should be rehydrated and all the metabolic corrections should be done. The oral feedings should be discontinued and adequate sodium, chloride and potassium replacement should be given. As pyloric obstruction is partial, most infants will be able to tolerate their gastric secretions and a nasogastric tube is not routinely required.

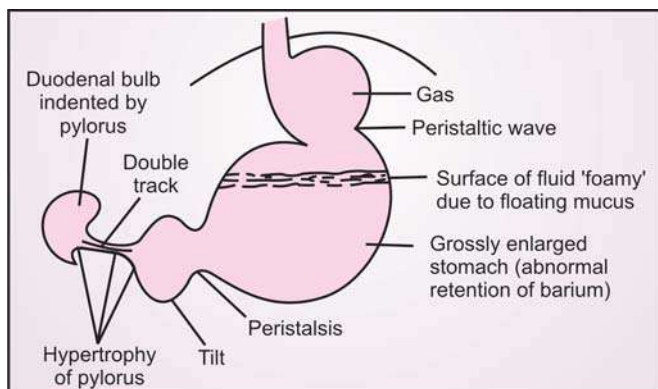

Fig. 40.1: Diagrammatic representation of the radiologic appearance of congenital hypertrophic pyloric stenosis. At times, classical X-ray signs may not be demonstrable

Atropine-like drugs act by relaxing the circular muscles and recently there has been an interest in this type of management. But due to disadvantages of prolonged hospitalization, incomplete response and risk of atropine related cardiac side effects coupled with uniformly good results of surgery, medical management of pyloric hypertrophy is not in vogue.

HIATAL HERNIA (*Partial Thoracic Stomach*)

In the commonest type of hiatal hernia in infants, cardiac end of stomach slides high up above the diaphragm and then back into the abdomen.

Manifestations include regurgitation or vomiting (often projectile), failure to thrive and anemia. Aspiration may cause pneumonia.

Differential diagnosis is from pyloric stenosis and esophageal reflux resulting from brain damage and gross scoliosis.

- Indications for surgical repair are:
- persistent vomiting,
 - esophagitis,
 - frequent aspiration, and
 - impending stricture.

ESOPHAGEAL ATRESIA AND TRACHEOESOPHAGEAL FISTULA

Esophageal atresia and tracheoesophageal fistula (EA+TEF) group of disorders (Fig. 40.2) comprise anomalies ranging from classical proximal esophageal atresia with distal tracheoesophageal fistula (85%) to just a H-type communication between esophagus and trachea (4%). The in-between shades include pure EA without TEF (8%), EA with both proximal and distal TEF (1.4%) and EA with only proximal TEF (<1%). Associated common anomalies are congenital heart disease (20-40%, VSD, TOF, PDA, ASD and PS), genitourinary anomalies (20-25%, hypospadias, undescended testes, hydronephrosis) and Gastrointestinal (20%, anorectal malformation, bowel atresias and malrotation) and skeletal defects (15%, vertebral defects, accessory ribs and sacral defects). The incidence of polyhydramnios in the mothers of such infant is high.

Clinical Features

The findings include excessive salivation (“blowing bubbles”), coughing, gagging and even choking, respiratory distress and cyanosis on the very first feed. Aspiration pneumonia may occur. Careful attention must be paid to a thorough examination of such baby to rule out associated anomalies.

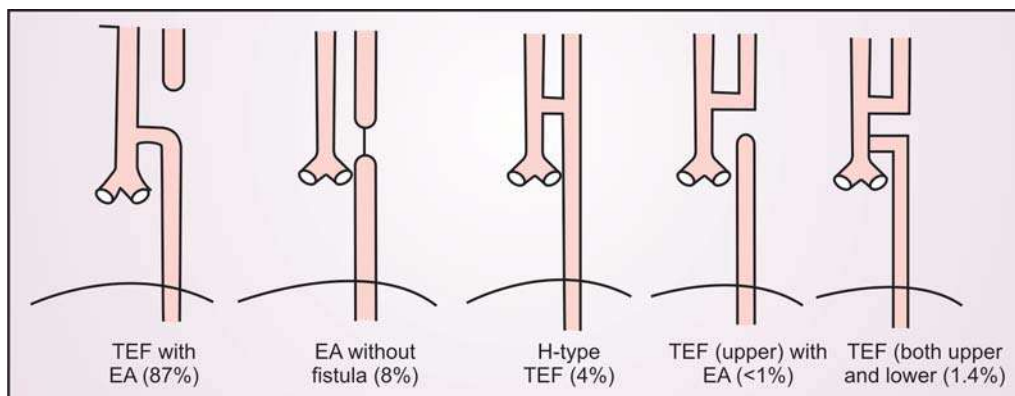

Fig. 40.2: Tracheoesophageal fistula and esophageal atresia

Diagnosis

Choking, cyanosis and regurgitation after the first feed, more so in a baby born to a mother suffering from polyhydramnios, must arouse a strong suspicion.

On suspecting the condition, oral suction should be done to clear the pooled oral secretions before an attempt to pass a catheter is done. Then a stiff radioopaque catheter 8-10 french size (like a commonly available red rubber catheter) is passed into the upper esophagus till a hitch is felt, and is secured. Chest and abdominal X-rays are taken in anterior-posterior and lateral views. The distal extent of upper pouch can thus be evaluated. Presence of gas in stomach indicates communication of the distal esophagus with the trachea. A note should be made of associated pneumonitis, any cardiac anomaly, skeletal defects and intestinal abnormalities. An echocardiogram and a renal USG is a part of the work-up of such a child.

If H-type TEF is suspected, a prone lateral view of chest with instillation of water-soluble contrast by a tube placed in the esophagus as it is withdrawn is recommended for demonstration of fistula. If the suspicion is strong and contrast study equivocal, bronchoscopy remains the gold standard for diagnosis.

5

Treatment

Early diagnosis, adequate preoperative preparation and surgical repair may prove life saving. The usual repair is primary end-to-end anastomosis with ligation of the fistula. If it is not possible to do anastomosis or the baby has moderate or severe pneumonitis, gastrostomy is performed. The repair of the esophageal pouch is done when the baby is clinically stable.

After surgery, the baby is given intravenous fluids for 48 hours. On third postoperative day, feeding through gastrostomy or transanastomotic tube is started. By tenth day, oral feeding may be begun provided the general condition of the baby is good and a contrast esophagogram reveals adequate healing.

Babies with H-type fistula require division of fistula by cervical approach with repair of both trachea and esophagus.

Most babies with pure esophageal atresia have a long gap, which is not amenable to anastomosis. Either a delayed primary repair or esophageal replacement is required for such babies.

During follow-up an eye is kept, as these babies are prone to develop anastomotic strictures. Evalua-

tion is done by barium studies and then esophageal dilatations may be required.

CONGENITAL DIAPHRAGMATIC HERNIA (CDH)

Etiopathogenesis

This condition is characterized by herniation of abdominal contents into thoracic cavity as a result of a developmental defect in the diaphragm (usually through the posterolateral foramen of Bochdalek on left side), pulmonary hypoplasia and malrotation of gut. Associated anomalies include esophageal atresia, omphalocele, CNS lesions, cardiovascular lesions and syndromes as trisomy 21, trisomy 13, trisomy 18.

Clinical Features

In the present era, a reliable diagnosis can often be made by an antenatal ultrasonogram performed at any time beyond 14 weeks as routine or later for evaluation of polyhydramnios. All such mothers should be referred to higher tertiary care centers for immediate neonatal care and surgery.

80-90% of the affected infants have neonatal respiratory decompensation within the first hour of life with tachypnea, retractions, cyanosis and gasping. Clinically these neonates have asymmetric funnel chest with shift of the mediastinum, absent breath sounds and presence of peristaltic sounds on the affected side. Heart sounds are displaced and abdomen is scaphoid.

10-20% of children who present later do so with recurrent chest infections, abdominal pain or features suggestive of gastric volvulus.

Diagnosis

A plain X-ray of abdomen and chest in a suspected case shows intestinal loops in the chest cavity, a finding diagnostic of CDH (Fig. 40.3). It is appropriate to do blood gas analysis to assess the extent of hypoxia and acidosis.

Treatment

After confirmation of diagnosis all efforts are made to stabilize the cardiorespiratory system. As the respiratory distress in an infant with CDH results from interplay of two factors—uncorrectable pulmonary hypoplasia and potentially controllable pulmonary

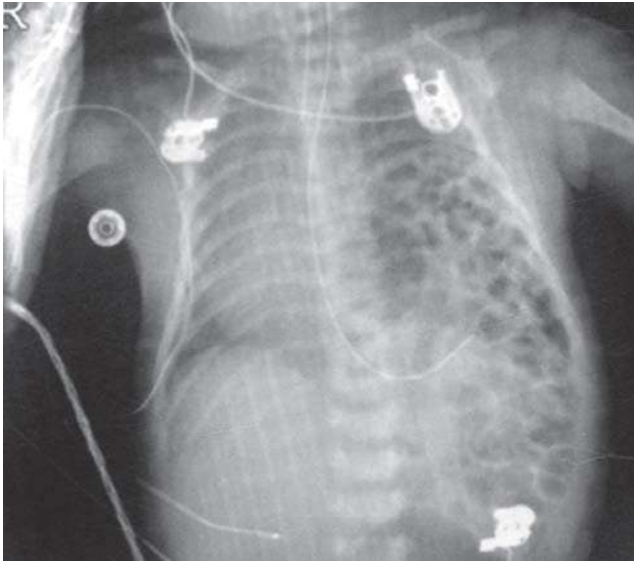

Fig. 40.3: Congenital diaphragmatic hernia (CDH). Multiple loops of bowel in the chest and a nasogastric tube courses into the chest cavity

hypertension, all efforts are made to decrease the pulmonary arterial pressures to decrease the right to left shunting.

A nasogastric tube is placed and a rectal syringing given to deflate the stomach and colon respectively. Ventilation by bag and mask is contraindicated and if required an endotracheal tube is placed. The infant is sedated and metabolic acidosis and hypoxia is corrected.

CDH is no longer considered a surgical emergency; instead it is a physiological emergency to control the hypoxia by adequate preoperative stabilization. Once stable the child is taken up for laparotomy and reduction of viscera with repair of the diaphragm.

Good results can be expected if the pulmonary hypoplasia is not very severe.

DUODENAL AND OTHER INTESTINAL ATRESIAS

Partial or complete occlusion of the intestinal lumen may occur congenitally in any part of the intestine commonly in duodenum (especially in Down's syndrome) followed by ileum, jejunum and colon. These children present with bilious vomiting and abdominal distension, which starts on day 1 of life. In general, lower the site of atresia more the abdominal distension and later the onset of vomiting (distension

is not seen in duodenal obstruction due to proximal obstruction). Plain abdomen X-ray film shows 'double bubble' sign in duodenal atresia. In jejunal atresias, 3 bubbles may be seen—'triple bubble sign' while in lower more air-fluid levels are seen.

Adequate hydration is ensured and the child is taken up for surgery. The procedure entails excision of the atretic segment and end-to-end anastomosis. Postoperatively resumption of bowel function is often delayed and these children require nutritional support in the form of total parenteral nutrition.

INTESTINAL MALROTATION

In the intrauterine life, the embryologic midgut undergoes a counterclockwise rotation by 270 degrees as it returns into the developing peritoneal cavity. As a result of this duodenojejunal flexure crosses over and lies to the left of spine and colon crosses over the small bowel mesentery and cecum assumes a position in the right lower quadrant. The term malrotation refers to incomplete rotation of the gut during intrauterine life so that cecum comes to lie below pylorus, root of mesentery becomes very narrow, ascending and transverse colon become mobile and vulnerable to twisting in a clockwise direction. This anatomical position predisposes to twisting to whole of the midgut on its narrow base—midgut volvulus which is an extreme surgical emergency as practically the whole of the small bowel may be lost. The other cause of obstruction in this scenario is due to Ladd's bands which course from abnormally located cecum across the second and third part of duodenum and cause external compression on duodenum.

Manifestations include:

1. *Acute midgut volvulus:* Sudden onset bilious vomiting, rectal bleeding, abdominal distention and feeble or absent bowel sounds and shock. Most of these patients present in the first month of life.
2. *Chronic midgut volvulus:* Recurrent abdominal pain and chronic malabsorption are the manifestations.
3. *Duodenal obstruction:* It may occur secondary to Ladd's bands leading to acute upper GI obstruction. More common in neonates and infants, the clinical picture includes recurrent forceful bilious vomitings without abdominal distension.

Diagnosis is from a plain abdominal film showing a large stomach bubble with few distal gas shadows.

Barium meal studies show that the duodenojejunal junction lies over or to the right of spine and cecum is higher up. The small bowel loops are predominantly on the left side of the abdominal cavity.

Ultrasound may show abnormal orientation of the superior mesenteric artery and veins establishing the diagnosis.

Treatment is exploratory laparotomy followed by lysis of the Ladd's bands and widening of the base of the mesentery. A delay in surgery may result in bowel compromise and gangrene.

INTUSSUSCEPTION

The disorder is characterized by telescoping of one of the portions of the intestine into a more distal portion, leading to impairment of the blood supply and necrosis of the involved segment. Of the three forms (ileocolic, ileoileal and colocolic), ileocolic is the most common. It is the most frequent cause of intestinal obstruction during the first 2 years of life.

5 *Etiologic considerations* The most common form is idiopathic and occurs classically between 4 and 7 months of age. A pathologic lead point may be found in only 2-8% of the cases, especially after 2 years of age. The predisposing factors include Henoch-Schoenlein purpura, Meckel's diverticulum, parasites, constipation, inspissated fecal matter in cystic fibrosis, foreign body, lymphoma and infection with rotavirus or adenovirus.

Clinical Features

These include episodic abdominal pain, vomiting and rectal passage of bloody mucus. Fever and prostration are usually appear 24 hours after the onset of intussusception and signify transmural migration across congested serosa. A sausage-shaped lump may be palpable in the upper abdomen in early stages. Rectal examination may show a cervix-like mass and blood on the examining finger (Fig. 40.4).

Diagnosis

Plain X-ray abdomen may reveal absence of bowel gas in the right lower quadrant and dilated loops of small bowel.

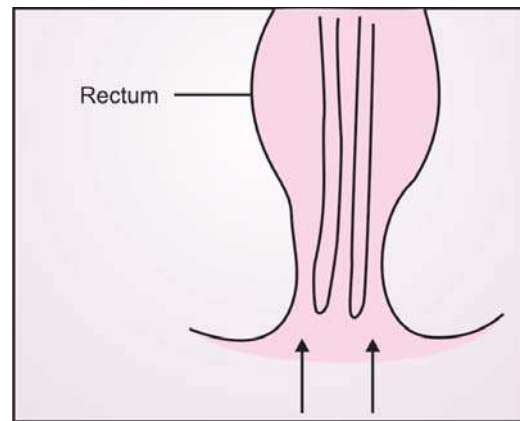

Fig. 40.4: Intussusception. Note that finger can be inserted into the rectum past the intussusceptum

Ultrasound will show a target sign in upper abdomen or in left iliac fossa due to presence of intussusceptum within the bowel.

Barium enema may show the intussusception as an inverted cap or a claw sign may be seen. There is an obstruction to the retrograde progression of barium into ascending colon and cecum. In the area of intussusception, there may be a ceiling-spring appearance to the column of barium.

Treatment

Conservative hydrostatic reduction gives good results in a large majority of the cases, provided that there is no evidence of strangulation, perforation or severe toxicity. It is performed by insertion of an unlubricated balloon catheter into the rectum. The balloon is then inflated and pulled down against the levator ani muscles. Thereafter, buttocks are strapped together. From a height of 90 cm, barium is allowed to flow into the rectum. Under fluoroscopy, the progress of barium is noticed. Total reduction is judged from:

- Free flow of barium into the cecum and reflux into the terminal ileum.
- Disappearance of the lump,
- Passage of flatus and/or stools per rectum,
- Improvement in the patient's general condition
- Passage of charcoal, placed in child's stomach by the nasogastric tube, per rectum.

Surgical/ reduction is indicated in patients who are unfit for hydrostatic reduction or who fail to respond to hydrostatic reduction after 2 attempts.

Prognosis

Left unreduced, intussusception is invariably fatal. Spontaneous reduction with recurrent episodes is known in older children.

HIRSCHSPRUNG'S DISEASE

Also called *congenital megacolon*, this disorder results from absence of parasympathetic ganglion cells in both Meissner and Auerbach plexuses at rectosigmoid segment with or without involvement of some additional part of the distal large bowel. The patients with *Down syndrome*, show far higher incidence. In males, it is about five times more frequent.

Constipation (persistent, not responding to various measures,) abdominal distention, vomiting and growth failure may begin soon after birth. Often, constipation may alternate with paradoxical diarrhea. The patient is generally grossly malnourished with multiple nutritional deficiencies. The loops of bowel may be palpable.

On rectal examination, no stool is found. But, as soon as the finger is removed, the child may pass lots of flatus and watery stool. This observation is in sharp contrast with the loaded rectum of *psychogenic megacolon*.

Any child in whom a strong clinical suspicion of congenital megacolon is there should have.

X-rays studies An upright plain film shows remarkably distended bowel with gas and stools. At times, air-fluid levels and air in the wall of the gut may be present.

Barium enema in a newborn may show prolonged retention of barium for over 24 hours. In later age group, it shows that the involved segment is constricted and has irregular outline. The colon proximal to this spastic segment is grossly distended. In between the distended and the constricted segment there is so called "transition zone" which is considered diagnostic for Hirschsprung's disease. In a less classical case the only finding may be rectosigmoid inversion, i.e. sigmoid has a larger diameter than the rectum.

Rectal biopsy This is the gold standard for making the diagnosis. The best site for obtaining rectal biopsy in such a child is about 5 cm above mucocutaneous junction. Absence of ganglion cells in the plexuses confirms the diagnosis.

Treatment

Medical treatment with stool softeners and repeated enemas with isotonic saline are recommended only while waiting for surgery. During this period attempts should be made to maintain fluid and electrolyte balance and to build up the nutritional status. Antibiotics are indicated in the presence of enterocolitis, which is quite common and a continued threat to life in this disorder.

The *treatment of choice is surgery*, involving resection of the involved (aganglionic) segment and end-to-end anastomosis to establish continuity between the rectum and the proximal segment. Various types of pull through operations namely Soave's, Duhamel's and Swenson's pull through have been devised, but all of them essentially achieve the same abovesaid goal. It is advisable to perform colostomy prior to this operation, more so in poor-risk cases. The best time to perform the main operation is at or soon after the infant has attained the age of 6 months.

Prognosis

Unoperated cases are always at risk of enterocolitis, obstruction or perforation, which may prove fatal.

Following surgery, outlook for life is excellent. Over 90% of them recover completely with normal growth and normal bowel habit. Occasionally fecal incontinence due to damage caused during surgery may become troublesome.

MECONIUM PLUG SYNDROME

The term refers to impaction of a thick plug of meconium in the distal colon leading to manifestations of intestinal obstruction. It usually responds to a rectal wash, which brings out the obstructing meconium plug. It has a broad whitish head and a greenish meconium tail followed by a light-colored meconium. Some neonates may need another wash before proper defecation pattern develops.

MECONIUM ILEUS

This condition occurs in neonates with cystic fibrosis. Refer Chapter 24 (Pediatric Gastroenterology). The viscid mucus tends to choke the lumen of the intestine, causing manifestations of distal intestinal obstruction notably pellets of meconium are found in terminal

ileum. At times, meconium may be palpable in the right lower quadrant of abdomen as a doughy and rubbery mass.

A plain abdominal X-ray reveals dilated intestine without fluid levels and a gastrograffin enema highlights the microcolon.

Treatment is surgery, provided that the enema has failed to relieve the obstruction by dissolving the inspissated mucus. Surgery involves either a tube enterostomy to facilitate the wash outs directly from the terminal ileum or creation of a double barrel or a Y stoma.

MECKEL'S DIVERTICULUM

Abnormal persistence of embryologic vitellointestinal duct results in Meckel's diverticulum. It is seen in 2% of population, 2 ft (60 cm) from the ileocecal junction, is generally 2 inch (5 cm) long, containing heterotopic pancreatic tissue in 2% cases and is often symptomatic before 2 years of age.

Presentation is with painless lower gastrointestinal bleed or obstruction due to a band going up to umbilicus or perforation secondary to ulceration due to ectopic gastric mucosa. Some cases may present with right lower quadrant pain presumably due to inflammation of the diverticulum.

Most important diagnostic tool is high index of suspicion. Confirmation of diagnosis is by a barium meal study or, better, a technetium-99m-labeled radionuclide scan.

Treatment is surgical excision of the diverticulum - diverticulectomy.

NECROTIZING ENTEROCOLITIS (NEC)

This is the most common and most serious gastrointestinal condition encountered in the neonatal intensive care unit (NICU). It is discussed in details in Chapter 17 (Neonatology). Table 40.1 lists the indications of surgery in NEC.

Table 40.1: Indications of surgical intervention in NEC

Definite indications	Probable indications
A palpable abdominal lump	Abdominal tenderness
Pneumoperitoneum	Severe hemorrhage
Abdominal wall erythema	Clinical deterioration
Positive abdominal tap (paracentesis)	Platelets <100,000 /mm ³
X-ray abdomen: dilated loops, gasless with ascites	

APPENDICITIS

This is the most common surgical emergency of childhood. It manifests initially with the classical triad of periumbilical pain followed by vomiting and fever. Later, pain shifts to right lower quadrant due to irritation of the adjacent peritoneum. Untreated cases go on to develop perforation peritonitis. The pain becomes generalized, fever and tachycardia increase and the abdomen becomes tender and distended. In a fortunate circumstance omentum seals off and localizes the peritonitis and an abscess is formed in the right lower quadrant or pelvis.

A persistent direct tenderness over McBurney's point and rigidity of the overlying rectus muscle is highly suggestive of acute appendicitis. In doubtful cases, imaging studies like ultrasonogram or a non-contrast enhanced thin cut CT scan may be helpful.

The appropriate treatment for acute appendicitis is surgical appendectomy within a few hours of diagnosis. In the event of a localized appendicular abscess, it should be drained by open or percutaneous technique and appendectomy performed in 4-6 weeks.

ANORECTAL PROBLEMS

IMPERFORATE ANUS AND OTHER MALFORMATIONS

Imperforate anus with fistula may be of high, intermediate or low variety.

In the high variety, the defect is situated above the levator ani funnel and the fistula opens into the urinary bladder (rectovesical fistula) at the level of the bladder neck in males and vagina (rectovaginal fistula) in females,

In the intermediate variety, the defect lies below the levator ani funnel and is associated with fistula into the posterior urethra (rectourethral fistula).

In the low variety, the defect is below the levator ani funnel and the fistulas open at the site of anus, perineal raphe or scrotal raphe in males and vestibule or vulva in females.

For determining the level of the defect, it is useful to perform a radiograph with the infant held upside down (suspended by legs). In this procedure, termed "invertogram", air passes down the blind rectum and rises up in this position to demonstrate the level of rectal pouch.

Treatment of low variety (primarily perineal fistulas) is a simple anoplasty without a protective colostomy. Two weeks following operation anal dilatations are started and gradually increased to the size of a normal anus. Prognosis is excellent.

The currently recommended approach for high and intermediate varieties is a colostomy during the neonatal period followed by corrective surgical repair later in the first year of life *per se*, prognosis is good in imperforate anus without fistula with 80% subjects attaining good bowel control between 3 to 4 years of age. Minimal soiling may continue in the rest.

ANAL FISSURE (*Fissure-in-ano*)

Anal fissure is the most frequent cause of fresh rectal bleeding and usually follows a tear or small laceration of the mucocutaneous junction of the anus during passage of a hard fecal matter in a severely constipated child. A vicious cycle of constipation—painful defecation—stool retention constipation sets in. A simple anal examination demonstrates the fissure. Treatment aims at softening stools by dietary correction and use of stool softeners so that the healing area is not stretched. Surgical intervention in the form of excision of the fissure, anal sphincterotomy or stretching of anus is in actuality not required.

PERIANAL ABSCESS AND FISTULA

Two types are known:

1. A self-limiting benign form, which occurs in infants with no particular predisposition and requires no treatment.
2. A serious form which occurs after the age of 2 years and has such predisposing factors as neutropenia, leu-kemia, diabetes mellitus, acquired immunodeficiency syndrome, Crohn disease, peri-or rectal surgery (imperforate anus, Hirschsprung's disease) or use of immunosuppressants.

Manifestations in the benign type include fever, rectal pain and perianal cellulitis. In the benign type, a pustule forms and the abscess is drained out. Occasionally it may need drainage under local anesthesia. If a fistula has been formed, a fistulectomy is required.

In the serious type, cellulitis becomes more fulminant and spreads upward into the ischioanal fossa, leading to toxemia and even septicemia. In addition to aggressive treatment with broad-spectrum

antibiotics, wide excision and drainage become mandatory. Fistulas in these cases are difficult to treat.

PILONOIDAL SINUS AND ABSCESS

The term, pilonidal sinus, denotes a depression or dimple in the intergluteal cleft at the level of the coccyx in otherwise normal infants. Some of these children may develop pilonidal abscess, which may need incision and drainage followed by an en bloc resection of the tract.

ANOMALIES RELATED TO THE UMBILICUS

VITELLOINTESTINAL FISTULA

This is persistence of the entire vitellointestinal tract duct. The infant presents with an umbilical sinus that keeps discharging either mucus or even stools.

Probing shows a tract that leads down from the umbilicus and passage of tube into the tract causes exit of a greenish intestinal fluid. The fistula may be complicated by kinking or internal herniation. Treatment is surgery.

UMBILICAL POLYP

It is a intestinal mucosa lined patch in the umbilicus that presents with discharging umbilicus. Treatment is surgical excision.

UMBILICAL HERNIA

Refer Chapters 17 and 42.

EXOMPHALOS (OMPHALOCELE) AND GASTROSCHISIS

Exomphalos is characterized by herniation of the abdominal viscera through a wide-open umbilicus, the magnitude of herniation varying with the size of the umbilical patency. The exomphalos has a sac lined by a translucent membrane that merges with the skin. It may be seen as a component of Beckwith syndrome (exomphalos, macroglossia, gigantism). More than 1/3 of the cases have major cardiac anomaly warranting an echocardiogram.

Gastroschisis is characterized by herniation of the abdominal viscera through a defect in the abdominal

wall, the umbilicus remaining well-formed without any opening. Unlike in exomphalos, there is no sac in gastroschisis. Intestinal atresia is associated in upto 20% of the cases the most frequent association.

Surgical treatment aims at reduction of the abdominal viscera back to the abdominal cavity and closure of the abdominal wall. Due to exposure of the intestine these infants are at risk of evaporative fluid losses and requires aggressive fluid therapy and proper coverage of sac and viscera with sterile plastic bag till surgery. Other life threatening issues are infection and hypothermia.

Post surgery babies often take time to resume bowel activity and in this regard TPN has improved the outcome in last 2 decades. Ventilation may be required for giant omphaloceles, which are managed with staged repair.

ANOMALIES OF THE HEPATOBILIARY SYSTEM

EXTRAHEPATIC BILIARY ATRESIA (EHBA)

5

The obliterative disorder of extrahepatic bile ducts, an important cause of prolonged obstructive jaundice, usually manifests during neonatal period.

Etiopathogenesis

It is, by no means, a developmental defect. Three hypotheses have been put forward about its etiology. First, it may well result from intrauterine viral infection which, when severe enough, causes inflammatory degeneration of the bile ducts and their replacement by fibrous tissue. Secondly, intrauterine ischemia of bile ducts has been incriminated as the cause of degeneration, disappearance and replacement with fibrous tissue of bile ducts. Thirdly, an unknown autoimmune reaction, could be responsible for damage of bile ducts.

Currently, three anatomic types are recognized.

Type I Atresia of common bile duct, *Type II* Atresia of common hepatic duc.

Type III Atresia at porta hepatis.

Type III is the most common type, accounting for over 85% of the cases and is also labeled as the uncorrectable variety.

It must be appreciated that the obliterative process is of a progressive nature. Delay in corrective surgery beyond 3 months of age significantly reduces chances

of finding patent ductules at porta hepatis. Liver biopsy at this stage may show intracellular and intracanalicular cholestasis, inflammatory cell infiltration, intestinal fibrosis, degeneration and proliferation of ducts and even giant cell formation. This picture is very much similar to that seen in neonatal hepatitis.

Clinical Features

The earliest manifestation is jaundice appearing round about the seventh day after birth (even days and weeks later). Jaundice, which is of obstructive type, is mild to begin with but progressively becomes severe. Stools are clay-colored (even white) and putty-like. Urine is heavily bile-stained. Skin in due course becomes bronze, olivegreen in color. Hepatosplenomegaly (Fig. 40.5) and vitamin deficiencies, especially hemorrhages due to vitamin K deficiency, may occur.

Diagnosis

Main differential diagnosis is from neonatal hepatitis (Chapter 25). However, at times, no single or battery of testes may conclusively differentiate the two. Such cases should have operative cholangiogram before 8 weeks age to demonstrate the patency or obliteration of bile ducts at a specialized center.



Fig. 40.5: Extrahepatic biliary atresia. Besides hepatosplenomegaly, the infant had gross obstructive jaundice and hemorrhages

Treatment

The surgical procedure of choice is Kasai hepatoportoenterostomy. The basis of this procedure is that, although extrahepatic bile ducts are fibrosed and obliterated, a good number of patent ductules converge at porta hepatis and when transected, discharge the pentup bile. In this operation, a loop of jejunum is anastomosed to the transected porta hepatis. In due course, ductal epithelium grows circumferentially and unites with the jejunal epithelium.

Prognosis

With early surgery, 40 to 50% long-term survival is reported. Most of the survivors may however, show disturbed liver function, esophageal varices and hepatosplenomegaly.

Recent advances include liver transplant if the Kasai's procedure fails to result in adequate drainage. Good results have been reported from the USA and Japan.

CHOLEDOCHAL CYSTS

No longer considered rare, choledochal cysts are congenital dilatation of the common bile duct that may end up in progressive biliary obstruction and biliary cirrhosis.

Varieties

Five types of choledochal cysts are currently recognized:

- Type 1 : Saccular or fusiform dilatation of the extrahepatic biliary tree.
- Type 2 : Diverticulum of the extrahepatic duct.
- Type 3 : Choledochocele
- Type 4 : Multiple cysts, intra or extrahepatic, or both
- Type 5 : Single or multiple intra or extrahepatic cyst. The most common types are the cylindrical and spherical cysts. Around 90% are situated in the extrahepatic region.

Etiopathogenesis

The etiopathogenesis remains speculative. The following explanations have been put forward:

1. Persistence of hepatic antrum from embryonal stage.

2. Unequal growth during the solid stage of development.
3. Congenital localized weakness of the duct wall.
4. Distal obstruction due to abnormal choledocho-pancreatic junction with a long common excretory duct and a wide angle.

The possible mechanisms involved in the development of these cysts are:

1. Increased intraluminal pressure due to:
 - a. Abnormal choledochus sphincter inferior.
 - b. Fibrosis of sphincter of Oddi.
 - c. Post-inflammatory ductal stenosis.
2. Weakness of the duct wall due to:
 - a. Congenital cause.
 - b. Pancreatic enzymes.
 - c. Chemical substances (bile plus pancreatic juice).

Clinical Features

The disease affects females 4 times more than males. In the infantile variety that accounts for 75% of the cases, presentation is with cholestatic jaundice (acholuric stools, dark-colored urine), smooth hepatomegaly, and severe liver dysfunction. Rarely, gallbladder may be palpable as a lump.

In the adult variety, the older child presents with classic triad of abdominal pain, jaundice and abdominal lump. Evidence of acute cholangitis in the form of pyrexia, right upper quadrant tenderness, leukocytosis, etc. may be present.

Diagnosis

Ultrasound is the best diagnostic tool for detecting both the intra- and extrahepatic choledochal cysts. This modality may identify such cysts even prenatally.

A HIDA scan may also prove useful by delineating the cyst and provides some information about the liver function also.

MRCP (Magnetic resonance cholangio-pancreatography) is very accurate and gives high resolution information about the exact ductal anatomy. Disadvantages are its cost and availability.

Treatment

Primary excision of the cyst and Roux-en-Y choledochojejunostomy is the treatment of choice. This procedure has uniformly good results. Postoperatively,

rarely there is risk of suffering from such complications as anastomotic stricture, which leads to recurrent cholangitis.

CHOLECYSTITIS (CALCULUS TYPE)

See Chapter 25 (Pediatric Hepatology).

GENITOURINARY PROBLEMS

OBSTRUCTIVE UROPATHY

Congenital Ureteropelvic Junction (UPJ) Obstruction

This is the most frequent site of obstruction in the upper urinary tract and is the most common underlying disorder leading to a diagnosis of antenatally detected hydronephrosis. Most of the time obstruction is due to improperly developed musculature at UPJ. Other causes are from aberrant vessels (abnormal lower polar renal arteries crossing the UPJ), bands, kinks, valves, polyps, intrinsic anomalies or vesicoureteral reflux. It is bilateral in 20% cases. It can be diagnosed antenatally by ultrasonography at 20 weeks or postnatally by IVU, diuretic renal scan and VCU. Antenatal intervention is indicated in bilateral obstruction with equivocal function diagnosed early in intrauterine life. Indications of postnatal surgery are symptomatic obstruction, especially with compromised renal function and presence of caliectasis, decreasing function on follow-up nuclear scans or thinning of cortex on USG.

Posterior Urethral Valve (PUV)

This is the most severe of the obstructive uropathies and can be diagnosed antenatally by ultrasonography. Anatomically there is obstructing membrane of valve leaflets in the posterior urethra just distal to verumontanum. Manifestations result from the severe bladder outflow obstruction that accrues. Postnatally, manifestations include failure to thrive (FTT), dehydration with dyselectrolytemia and acidosis, dribbling, straining to pass urine, UTI, and a persistently palpable urinary bladder.

Diagnosis is confirmed by ultrasonography and voiding cystourethrogram (VCU).

Surgical intervention is in the form of decompression of the bladder followed by transurethral

ablation of the valves. Rarely, if the child does not respond favorably to this procedure or cystoscopy is not feasible, vesicostomy or even ureterostomy may be required.

RENAL STONE

As a rule, renal stones are far less common in childhood than in adults. Incidence in boys is higher than in girls.

Etiology

The causes of urolithiasis in pediatric age group are:

1. Metabolic
 - a. Idiopathic calcium oxalate stones because of absorptive or renal hyperoxaluria, hyperuricosuria, hypocitruria or most commonly hypercalciuria.
 - b. Primary hyperoxaluria
 - c. Orotic aciduria
 - d. Enteric urolithiasis
 - e. Hypercalcemic states: hyperparathyroidism and immobilization
2. Renal disorders
 - a. Cystinuria
 - b. Renal tubular acidosis
3. Secondary
 - a. Infection
 - b. Obstruction, commonly with PUJ obstruction
 - c. Structural or functional bladder anomalies
 - d. Post urinary diversion procedures
4. Endemic bladder and renal stone disease

Clinical Features

These include recurrent infections, renal colic (colicky abdominal or flank pain), hematuria and passage of gravel in urine. The signs and symptoms of the underlying disease may also be present. In an infant the features are often non-specific.

Diagnosis

It is imperative to conduct a full metabolic work-up to rule out the above-mentioned causes otherwise a recurrence is likely. The work-up thus includes—renal function test, serum calcium and phosphorus, uric acid and hemogram. Fresh urine sediment should be examined under microscope for presence of crystals. It

is equally important to measure the pH and to do the rest of the routine exam for RBCs and casts. 24-hour urine collection is done and excretion rates for calcium, phosphorus, uric acid, cystine and magnesium are estimated.

X-ray and ultrasonography of abdomen confirm the diagnosis of urolithiasis and rule out associated structural abnormalities. For planning of therapy, an IVP may be required if some anatomical variation is expected.

Treatment

Treatment is directed at controlling the urinary tract infection if present, and assuring high fluid intake, which may reduce the concentration of precipitate crystalloids and *per se* dissolve the calculus or push it out.

In case an underlying metabolic cause is discovered, proper preventive measures should be instituted accordingly.

Options for removal include extracorporeal shock wave lithotripsy (ESWL), percutaneous techniques and open surgery.

PRIMARY BLADDER STONE DISEASE

The occurrence of bladder stone despite the absence of any obstructive uropathy, local predisposing cause in the bladder itself or infection among children tropical regions has aroused considerable interest. Besides India, it has been endemic in North Africa, Syria, Saudi Arabia, Iran, Burma, Pakistan, Thailand, Afghanistan and Indonesia. In India, the disease is common in northeast states, Andhra Pradesh and Rajasthan followed by Delhi, Uttar Pradesh, Haryana, Punjab and Jammu and Kashmir. A large majority of the patients are under 10 years age. Males are affected more often than females. The socioeconomic status of the families is usually poor.

Etiology

The exact etiology of primary bladder stone disease is not clear. The evidence condemning malnutrition is convincing though equivocal. Among the nutritional factors, borderline deficiency of phosphate appears to play a major role. High oxalate diet also contributes to this condition. It has been postulated that recurrent

attacks of diarrhea may contribute to the problem by causing dehydration and concentrated urine. Likewise, recurrent febrile illnesses have also been incriminated in its etiology. Diet rich only in cereals without any milk or animal protein results in high urinary ammonium concentrations. Coupled with high urates, this leads to ammonium urate stones, the most common type in this scenario.

Clinical Features

Manifestations include dribbling of urine, painful micturition (pain over tip of penis is typical) and abdominal discomfort. Hematuria occurs occasionally. Superimposed urinary tract infection may complicate the clinical picture. In some children, genital handling, masturbation and rectal prolapse may also be noticed. In a vast majority of the cases suffering from this disorder, there are no associated renal stones. Furthermore, recurrence rate following surgery is low. The stones are composed of mainly urates and oxalates.

Treatment

Surgical removal is the sole treatment of bladder stone.

PRIAPISM

Rarely, children may suffer from nonerotic erection of penis for sustained periods which may be longer than 24 to 36 hours.

Etiology

The etiologic factors include leukemias, sickle-cell disease and perineal trauma.

Treatment

Spontaneous resolution may occur.

Treatment of leukemia with chemotherapy and local irradiation, of sickle cell disease with rapid hypertransfusion using packed red cells, of perineal trauma with surgical drainage of affected areas and creation of vascular shunt between corpus spongiosum and corpora cavernosa so as to produce detumescence leads to resolution of priapism.

Sequelae include impotence, especially following posttraumatic priapism.

TIGHT EXTERNAL URETHRAL MEATUS (Meatal Stenosis)

A tight meatus with thin stream and, perhaps, some dysuria, on micturition may follow a healed meatal trauma, inflammation or ulcer, or an inappropriately timed circumcision. A generous meatotomy may be carried out.

PHIMOSIS AND PARAPHIMOSIS

Inability to retract the prepuce after the age of 3 years only should be regarded as *true phimosis*. As a rule, prepuce is unretractable at birth (*Physiologic phimosis*) but in 90% instances it becomes retractable by the age of 3 years. By adolescent, only 1% have phimosis. Phimosis may be congenital or secondary to inflammatory condition(s) of the glans or prepuce.

Physiologic phimosis requires no intervention. Standard treatment for pathologic or true phimosis is surgical circumcision.

Alternatively, betamethasone cream may be applied to the narrowed preputial skin twice daily for 4 weeks. After 2 weeks, the foreskin becomes soft and elastic and is retracted gently and gradually in increments. In a vast majority, this treatment proves successful.

Paraphimosis means that once the prepuce (phimotic) is retracted behind coronal sulcus, it cannot be reduced. Causing venous stasis and edema with severe pain. Advanced cases need circumcision. In others, reduction can be attained by application of lubricants under cover of heavy sedation.

HYPOSPADIAS AND EPISPADIAS

The term, *hypospadias*, denotes abnormal placement of the external urethral meatus on the ventral aspect of the phalus. The abnormal placement of the external urethral meatus on the dorsal aspect of the phalus. These cases need full evaluation for ambiguous sex and surgery .

AMBIGUOUS GENITALIA

Refer Chapter 34 (Pediatric Endocrinology).

INGUINOSCROTAL PROBLEMS

INGUINAL HERNIA

It results from persistence of the patency of processus vaginalis accompanying the spermatic cord. An



Fig. 40.6: *Inguinal hernia*. Note the obvious swelling in the left inguinal region on crying. In view of the potential risk of strangulation, it must be operated as early as possible. Also note the umbilical polyp in this subject

intermittent swelling in the inguinal or inguinoscrotal area appears, particularly on crying or straining (Fig. 40.6). It is reducible. Rolling of the cord between two fingers gives a feeling of crepitation. This is called “silk-glove sign”. It is helpful but not really diagnostic of inguinal hernia.

Inguinal hernia requires operative treatment as early as possible in view of high incidence of obstruction and strangulation. The complications may manifest as red, irreducible swelling with abdominal distention, vomiting and constipation (obstructed or strangulated hernia). Incidence of complications is higher in preterm infants.

HYDROCELE

The term, *hydrocele*, implies presence of peritoneal fluid within the tunica vaginalis.

Noncommunicating hydrocele is quite common in newborns and infants. It disappears spontaneously by the age of 6 months. Right side is involved more frequently though bilateral involvement also occurs. The scrotal swelling is nontender and well-transilluminated.

Communicating hydrocele is characterized by rapid change in size in the subsequent months. There is a communication with the peritoneal cavity through the patent processus vaginalis. Hernia may accompany it. Surgical intervention is indicated only when

hydrocele persists beyond one year of age. The operation involves ligation and division of patent processus vaginalis through a small inguinal incision.

UNDESCENDED TESTES (*Cryptorchidism*)

Refer Chapter 34 (Pediatric Endocrinology). If cryptorchidism is left as such, diminished spermatogenesis may follow in adult life.

EPIDIDYMO-ORCHITIS

Inflammation of epididymus (epididymitis) testes (orchitis) or both (epididymo-orchitis) usually occurs following infection with mumps and coxsackie B viruses.

In case of mumps, orchitis usually follows parotitis within 8 days and subsides in 4-5 days. The testis becomes tender and swollen with red and edematous adjacent skin. One in 3 affected testes show atrophy in the long run. Nevertheless, infertility is infrequent.

In case of coxsackie B viruses, orchitis (usually with epididymitis) follows recovery from illness characterized by fever and pleurodynia or meningitis.

ACUTE SCROTUM

Acute scrotal swelling may result from epididymo-orchitis, torsion of testis or its appendages, testicular trauma or idiopathic scrotal edema. It is of paramount importance to differentiate between testicular torsion and the other causes, as torsion is a surgical emergency. Uncorrected torsion leads to testicular necrosis. Treatment is immediate surgical intervention, correcting the torsion and fixing the involved testis to the scrotum to safeguard against future torsion.

HEAD AND NECK PROBLEMS

CLEFT LIP AND CLEFT PALATE

Refer Chapter 39 (Dental Problems).

CYSTIC HYGROMA (*Lymphangioma*)

These are massive, nontender, unilocular or multicystic tumors with semitransparent walls and thinning of the overlying skin. They make their appearance early in life—often at birth and occur in the head and neck region (Figs 40.7 and 40.8) in 75% of the cases.



Figs 40.7 and 40.8: Cystic hygromas. Also called “lymphangiomas”, these tumors are capable of causing complications by their extension into the thorax and compression. Prognosis following early surgical resection is excellent

With progression in growth, hygromas may cause tracheal compression and respiratory distress. In some cases, associated enlargement of the tongue may occur.

Complications are bleeding and infection. Presence of erythema over the tumor is a sign of superimposed infection.

Spontaneous regression does not occur. Treatment is surgical removal as early as possible. A large unilocular cyst may respond to intralesional sclerotherapy in the form of bleomycin, OK432 (extracted from strepto-coccus) or sodium tetradecyl sulphate.

THYROGLOSSAL CYST

It is a smooth rounded midline neck swelling which is connected by a tract to the base of the tongue, representing the persistence of the thyroglossal tract postnatally. It is likely to get repeatedly infected and burst. It should be differentiated from submental or pretracheal lymph nodes and ectopic thyroid gland, which, unlike the cyst, is always present at birth. Treatment is removal of the cyst along with the total tract by Sistrunk procedure. Excision of the body of the hyoid bone is a part and parcel of this procedure otherwise recurrence as likely.

BRACHIAL CYST

It presents late in childhood as a lateral fluctuating cystic swelling, full of a fluid with high cholesterol content, in the anterior triangle of the neck protruding from anterior border of sternocleidomastoid muscle. Treatment is excision.

BRACHIAL SINUS AND FISTULA

Branchial sinus is a discharging sinus at the anterior border of sternocleidomastoid (the junction of its middle and lower thirds) and extends to external auditory canal above as branchial fistula. Treatment is careful excision as the tract passes in between the external and internal carotid arteries.

STERNOMASTOID TUMOR (Sternocleidomastoid Tumor)

The term refers to a hard, immobile, fusiform and well-circumscribed mass, around 2 cm in diameter, which may be felt in the middle of the sternomastoid muscle, usually 10 to 14 days after birth. There are no inflammatory signs but the child has torticollis due to muscle shortening. In a large majority of cases, it slowly disappears by the age of about 6 months.

The cause appears to be a birth trauma, usually from a difficult breech delivery.

The condition must be differentiated from other causes of torticollis (Table 40.2).

Treatment consists in stretching the affected muscle to the overcorrected position by gentle manipulation several times daily. If response to conservative treatment continues to be discouraging by 6-12 months of age, surgical lengthening and division of the sternal portion of the muscle or from mastoid process at its origin followed by exercise program should be carried out. Else, the infant may develop asymmetry of the skull and face, cervicodorsal scoliosis and calcification in the involved muscle.

Table 40.2: Differential diagnosis of torticollis

<i>Muscular</i>	Sternocleidomastoid (sternocleidomastoid) tumor, neck muscle inflammation/trauma
<i>Congenital anomalies</i>	Malformations of atlas, congenital cervical scoliosis, occipitocervical invagination
<i>Rotatory fixation between C1 and C2</i>	Cervical adenitis, trauma, URI
<i>Neurogenic</i>	Posterior fossa (cerebellar) or spinal cord tumor in older infants and children.
<i>Gastrointestinal</i>	GER, Sandifer syndrome

MISCELLANEOUS PROBLEMS

ABSCESS

Abscess is a common pediatric surgery problem and signifies pus under pressure. Clinically there is painful swelling with redness of overlying skin, fever and fluctuation on palpation. Abscess can occur virtually in any body part. Examples are breast abscess, abdominal wall abscess, psoas abscess, liver abscess, etc. Treatment entails surgical drainage and appropriate antibiotics. As the most common organisms are gram positive cocci (staphylococcus and streptococcus penicillin group of drugs which also cover the penicillin-resistant strains, i.e. cloxacillin) are effective. Abscess in the dangerous area of the face requires energetic and prompt therapy.

FURTHER READING

Articles/Chapters

1. Jageer Hussain M. Congenital malformations. In Gupte S (Ed): *Recent Advances in Pediatrics (Special Vol. 5: Neonatology-2)*. New Delhi: Jaypee 2000;327-346.
2. Goswamy HL, Digra NC, Mengi Y. Congenital diaphragmatic hernia. In Gupte S (Ed): *Recent Advances in Pediatrics-13*. New Delhi: Jaypee 2003;293-315.
3. Gupta DK, Srinivas M. Intestinal obstruction. In Gupte S (Ed): *Recent Advances in Pediatrics-13*. New Delhi: Jaypee 2003;281-292.
4. Parekh BR, Parekh P. Common neonatal surgical emergencies. In Gupte S (Ed): *Recent Advances in Pediatrics (Special Vol 12: Neonatal emergencies)*. New Delhi: Jaypee 2003;393-421.

Book/Monograph

1. Huston JM, Woodward AA, Beasley SW. *Jones' Clinical Pediatric Surgery*. Victoria: Blackwell 1999.



CONGENITAL DEFICIENCY OF LONG BONES

Phocomelia is a reduction deformity (congenital amputation) in which there is gross reduction in the proximal part of the extremity so that distal part seems to be approaching the trunk.

Hemimelia refers to absence of forearm and hand, or leg and foot (Fig. 41.1).

Amelia means complete absence of limbs.

Treatment in most cases revolves around amputation and orthotic rehabilitation.

CLUB FOOT

The commonest type of congenital club foot is *congenital talipes equinovarus* (CTEV) in which foot is in plantar flexion and deviated medially.

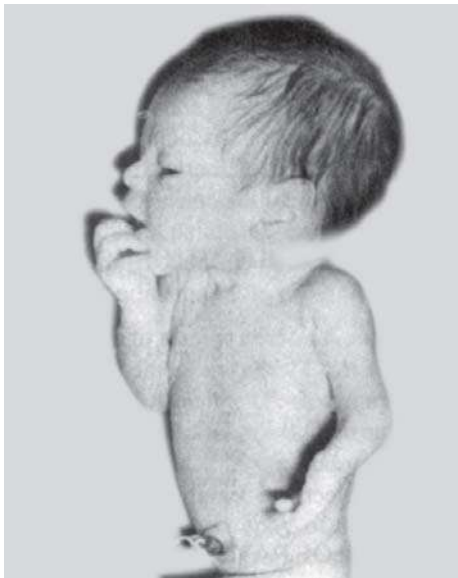

Fig. 41.1: Hemimelia

In the calcaneovalgus deformity, foot is dorsiflexed and deviated laterally.

Association of club foot and spina bifida is well-known.

Orthopedic treatment in the form of corrective manipulation with adhesive tapes, splints or casts and wedging is helpful, provided it is done as early as possible.

FLAT FOOT

The term, *flat foot*, denotes loss of medial longitudinal arch of the foot. Clinically, flat foot is recognized when the arch touches the ground on weight bearing or is close to the ground. Until age 2-3 years, foot normally appears flat because of absence of the medial longitudinal arch.

Flat foot may be congenital (calcaneovalgus deformity, hypermobility, rigidity with tarsal anomalies) or acquired (fracture of talus or calcaneus, tear of plantar ligaments, muscle imbalance, postural, bad gait, faulty shoes).

Treatment consists of conservative measures such as arch support, shoe modification and exercise. If this treatment fails, orthopedic intervention in the form of removal of calcaneus or, after age 10 years, arthodesis.

RADIAL CLUB HAND

The hand is deviated laterally because of partial or total absence of radius. Absence of thumb, congenital heart defect and a bleeding diathesis are frequent accompaniments. Orthopedic treatment is centralization of ulna in relation to hand and reconstruction of thumb by pollicization of index finger.

TRIGGER THUMB

In this condition, the thumb cannot be straightened since it is locked in flexion because of a nodular swelling of the long flexor tendon at the base of the thumb. Treatment is surgical incision of the constricting mouth of the tendon sheath.

POLYDACTYLY

An extra finger/toe, usually close to the metacarpophalangeal joint of the little finger/5th toe or the thumb, may occur as an isolated trait or as a component of such syndromes as Laurence-Moon-Biedl syndrome, Carpenter syndrome, Meckel-Gruber syndrome and trisomy 13. It may be rudimentary or articulated. Orthopedic intervention is in the form of ligation or excision at birth or amputation at about 1 year of age.

SYNDACTYLY

Fusion of digits/toes varies from a cutaneous web to a synostosis and may occur as an isolated trait or as a component of certain syndromes like Apert syndrome, Carpenter syndrome, de Lange syndrome, Holt-Oram syndrome, orofacial digital syndrome, fetal hydantoin syndrome, Laurence-Moon-Biedl syndrome, Fanconi pancytopenia, trisomies 21, 13 and 18, and polysyndactyly syndrome.

CONGENITAL CONSTRICTION BANDS/ RINGS

These are circumferential constrictions in the soft tissues, more frequently in legs and feet than arms and hands. Depending on magnitude of constriction, they cause obstruction in the circulatory and lymphatic channels, leading to localized edema. Associated foot deformities and superadded fractures of tibia and fibula are common. Treatment is excision of the constriction band.

CONGENITAL PSEUDOARTHROSIS OF THE TIBIA

In this condition, there is an aplasia of a portion (usually distal half) of the tibia, giving the impression of a nonhealing fracture in the neonate. It may

accompany neurofibromatosis. Orthopedic intervention is in the form of intermedullary nailing with bone grafting, vascularized fibular graft and electrical stimulation. Prognosis is poor.

DISLOCATION OF PATELLA

It may be congenital (ligamentous laxity on medial side of the joint, small lateral condyle of the femur, short quadriceps muscle) or posttraumatic. Two types are known: recurrent (occurring at intervals) and habitual (occurring whenever knee is flexed). Treatment is orthopedic correction.

KNOCK KNEE (*Genu Valgum*)

The term denotes medial angulation of knees because of outward deviation of the longitudinal axis of both tibia and femur. The concurrent finding is abnormally divergent ankles (intermalleolar distance >8 cm). Physiological knock knee is common in toddlers but it always disappears by age 7 years.

Treatment of a persistent knock knee is stapling or osteotomy.

The most common variety is idiopathic. It may also be secondary to bone softening (rickets, bone dysplasia, JRA), post-traumatic (fractures), paralytic (PPRP, CP), postinfective or neoplastic.

BOW LEG (*Genu Varum*)

The term denotes lateral angulation of knee joints because of inward deviation of longitudinal axis of tibia and femur. As a result, knees are abnormally divergent ("bow-like") whereas ankles are abnormally convergent.

Physiological bow leg, when the child begins to walk, is quite common. It resolves in due course. Other causes include rickets, postural, traumatic, developmental and endocrinal.

A persistent deformity warrants orthopedic intervention in the form of corrective osteotomy.

CLEIDOCRANIAL DYSOSTOSIS

It is characterized by absence of the outer third of each clavicle so that the patient can make his shoulders meet in front, high-arched palate, absent paranasal sinuses, defective teething and poorly developed spinal bones. No treatment is indicated.

HEMIHYPERTROPHY

In this congenital disease, one side of the body is significantly larger than the other. The hypertrophy is usually of the whole one side, including face, tongue, teeth and genitalia.

Associated with hypertrophy of one side may be malformations like neurofibromatosis, hemangioma, nevi, polydactyly, cryptorchidism, hypospadias, tumors and calcification of adrenals and ichthyosis (CHILD syndrome comprising congenital hypertrophy, ichthyosis and limb defects).

With gain in age, difference between the two sides often becomes less conspicuous.

SLIPPED CAPITAL FEMORAL EPIPHYSIS (SCFE)

This condition usually occurs in obese adolescents with delayed skeletal maturation or in tall and thin individuals with a recent growth spurt or in such endocrinal disorders as hypopituitarism, hypothyroidism or pseudohypoparathyroidism.

An endocrinal origin is suspected. Four clearcut groups are recognized: preslip, acute SCFE, acute on chronic SCFE and chronic SCFE.

Manifestations include a painful limp and pain in the anterior aspect of thigh with radiation to the knee. External rotation of the hips on flexion is a pathognomonic sign.

Radiographs (anteroposterior and lateral/frogleg view) are diagnostic. Orthopedic treatment is *in situ*.

Complications are osteonecrosis and chondrolysis.

DEVELOPMENTAL DYSPLASIA OF THE HIP (DDH)

Also termed *congenital dislocation of the hip (CDH)*, the global incidence of this condition varies from 0.7-15.5/1000 livebirths. It is rather uncommon in India.

Etiology

In breech presentation and other difficult deliveries, the head of the infant's femur may get dislocated upward and backward. Its constant pressure over the dorsal aspect of the ileum may cause development of a false acetabulum.

The defect occurs more frequently in females and is often hereditary.

Clinical Features

Every newborn must have an examination of the hips to rule out this disorder (Fig. 41.2). Asymmetry of the thigh, gluteal and knee creases, inability to abduct the hip fully, shortness of the affected leg, reduced spontaneous movements and a bulge of the femoral head must arouse suspicion. A good screening test (*Ortolani sign*) consists in abducting the hip passively. A clicking sound is heard from the hip at the end of the maneuver. It results from the jerking of the subluxated head as it reduces back into the acetabulum.

The *Barlow test* is the most important maneuver and consists in stabilizing the pelvis with one hand. Then, the opposite hip is adducted and a posterior force is applied. When the hip is dislocatable, it is readily appreciated.

Diagnosis

It is confirmed by X-ray and/or ultrasound of the hip.

Differential diagnosis in older children is from dislocation of hip seen in hypothyroidism, cerebral palsy and spastic paraplegia.

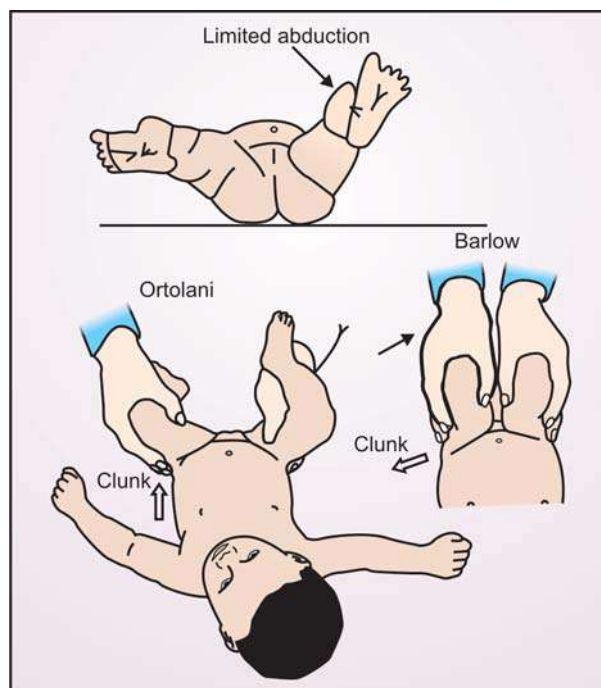

Fig. 41.2: Developmental dysplasia of the hip (DDH). Note asymmetrical abduction due to limited abduction of the infant's left hip (top), demonstration of the Ortolani maneuver (left) and Barlow maneuver (right)

Treatment

Treatment is close reduction and maintenance of the correction in position of abduction and flexion. Open reduction may become necessary if diagnosis is made late or if closed reduction has yielded unsatisfactory result.

Prognosis

Without treatment, delay in learning to walk may occur. If dislocation is bilateral, significant lordosis and waddling gait result. Complications include avascular necrosis, redislocation, acetabular dysplasia or residual subluxation and wound infection and other postoperative complications.

SCOLIOSIS

The term denotes alteration in normal spinal alignment occurring in the anteroposterior or frontal plane. It may be idiopathic (majority), congenital (hemivertebra, wedge vertebra, unsegmented bars, mixed), neuromuscular (CP, polio, myopathies), syndromal (neurofibromatosis, Marfan syndrome) and compensatory (leg-length discrepancy). Both clinical and radiologic evaluation (both PA and lateral standing films of whole spine, CT scan, MRI, myelography, tomography) is required. Treatment of progressive scoliosis is orthotic or surgical (posterior spinal fusion). Compensatory scoliosis warrants correction of the primary disease such as limb inequality.

KYPHOSIS

The term, *kyphosis*, refers to an enhanced angulation in the thoracic or thoracolumbar spine in the sagittal plane or a roundback deformity. It may be postural (roundback), congenital or idiopathic (Scheuermann disease). Clinical and radiologic evaluation is necessary. Treatment is orthotic and/or operative.

GENETIC SKELETAL DYSPLASIAS

OSTEOGENESIS IMPERFECTA (OI)

This is the most common hereditary osteoporotic syndromes and is characterized by fractures and skeletal deformities. At least 4 types are recognized.

OI type I is an autosomal dominant disorder characterized by osteoporosis and excessive bone fragility with fractures (Fig. 41.3), blue sclerae and conductive deafness (in adolescence/adulthood).

OI type II, a lethal syndrome, is characterized by low birthweight and length, hypotelorism with beaking of the nose, extremely short, deformed and bent limbs, broad thighs that are fixed at right angles to the trunk (Fig. 41.4), and crumpled long bones and

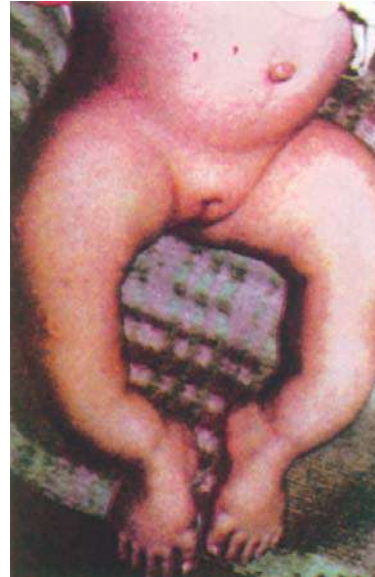

Fig. 41.3: *Osteogenesis imperfecta tarda*. Note the deformities secondary to multiple fractures. Blue sclera and deafness develop later



Fig. 41.4: *Osteogenesis imperfecta type II*



Fig. 41.5: Osteogenesis imperfecta type III



Fig. 41.6: Osteogenesis imperfecta: Radiologic picture depicting fractures

fractured and beaded ribs in X-ray studies. Whereas 50% are born dead (stillbirths), the remaining 50% die soon after birth due to respiratory insufficiency as a result of defective thoracic cage. Though a small proportion have autosomal recessive inheritance, most cases represent new autosomal dominant mutations. Prenatal diagnosis is through a combination of ultrasonography, X-rays and biochemical studies.

OI type III, an autosomal recessive disorder, is characterized by multiple fractures and blue sclerae which tend to become less blue with age (Fig. 41.5).

OI type IV, an autosomal dominant disorder, manifests any time from birth to adult life with fractures and deformities. The sclerae show a tendency to become less blue with age. Deafness is less frequent. In some cases, opalescent dentin may be observed.

Radiologic skeletal survey is mandatory for delineation of fractures and deformities (Fig. 41.6).

Management of *OI* type I, III and IV consists of careful nursing on a firm mattress or pillows (for neonates) and prompt splinting of fractures and correction of deformities.

MARFAN SYNDROME

It is characterized by arachnodactyly (abnormally long limbs, fingers and toes) as seen in (Figs 41.7 and 41.8), subluxation of the lens, hypotonia and hyperextensible

joints, cardiovascular disease such as aortic aneurysm, mitral valve prolapse (MVP) and other anomalies. Intelligence remains normal.

Upper/lower segment ratio after maturity is remarkably low. Length of middle finger is more than 1.5 times of its metacarpal. Fifth finger may show clinodactyly. Great toe is typically long. Ask the

5



Fig. 41.7: Marfan syndrome



Fig. 41.8: Note the arachnodactyly in Marfan syndrome

patient to close his fist and try to enclose the thumb within it. You would find that it protrudes beyond the medial edge of the hand. This is called *Sternberg sign*. In the so-called *wrist sign*, thumb and the little finger clearly overlap when encircling the wrist.

Homocystinuria is an important differential diagnosis and must be ruled out by demonstrating a negative urinary cyanide nitroprusside test or specific amino acid studies.

It is a generalized mesodermal dystrophy and may be inherited as a dominant trait. Around 15 to 30% cases are sporadic with new mutation. Each child of an affected individuals runs 50% risk of inheriting the number 15 chromosome with the Marfan mutation and thus being affected.

Marfan syndrome has an adverse effect on the sufferer's longevity.

ARTHROGRYPOSIS MULTIPLEX CONGENITA (AMC)

It refers to the congenital contractures of multiple joints (Fig. 41.9). Fibrous tissue replaces the affected muscles, partially or completely. Skin is usually thickened and other deformities like club foot may be there.

Besides the major form, *amyoplasia*, which is considered the classical syndrome, there are several other mild or incomplete forms of the disease. Familial occurrence is reported.

Etiologic hypothesis include a neuropathic origin supported by reduced number of anterior horn cells and a myopathic origin supported by diminution of movements *in utero*.

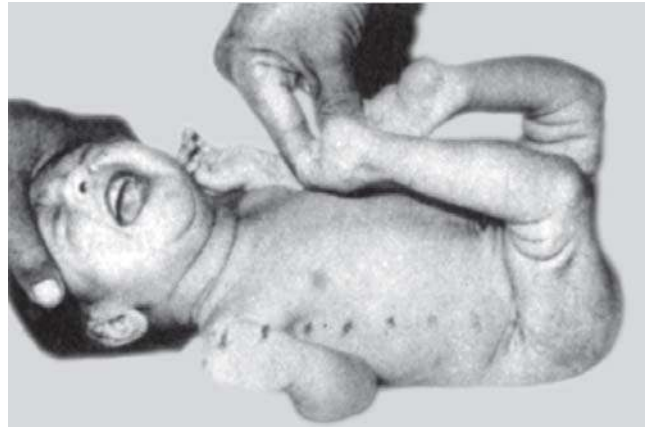

Fig. 41.9: Arthrogyposis multiplex congenita

Treatment is correction of orthopedic deformities followed by rehabilitation.

ACHONDROPLASIA

Achondroplasia, an autosomal dominant disorder, is characterized by severe short stature, short trunk and extremities with dominant shortening of the proximal segment (rhizomelia) (Fig. 41.10). Intelligence is normal. Bow legs, waddling gait, short and stubby fingers of nearly same size, large head with prominent forehead, and depressed bridge of nose, hypoplasia of the maxilla with relative mandibular prognathism, dental malocclusion with anterior open bite and lumbar gibbus which is replaced in the second year



Fig. 41.10: Achondroplasia

by a lumbar lordosis, recurrent otitis media, conductive hearing loss, sleep apnea and SIDS are other common associations.

The thickness of the bones and presence of irregular epiphyseal ends in X-ray is a characteristic feature of achondroplasia.

Complications include hydrocephalus, advanced bowing of legs, severe lumbar kyphosis or lordosis cervi-cal or lumbar spinal cord compression.

Physiotherapy and bracing in early childhood may ameliorate severe deformities of spine. Severe progressive leg bowing may be corrected by osteotomies in preadolescence or adolescence.

PSEUDOACHONDROPLASIA

This condition is a spondylometaphyseal dysplasia and has 4 types. It has a striking peripheral similarity to achondroplasia, a spondylometaphyseal dysplasia.

OSTEOPETROSIS (*Marble Bone Disease*)

This familial disease is characterized by excessive deposition of calcium in the medullary cavity of the bones which are weak and brittle. At least, nine forms are recognized, the most prominent being:

- Osteopetrosis with precocious manifestations
- Osteopetrosis with renal tubular acidosis
- Osteopetrosis tarda (Albers-Schoenberg disease)
- Pyknodysostosis
- Dysosteosclerosis

Infantile cortical hyperostosis (Caffey disease).

Clinical manifestations include myelopathic anemia, hepatosplenomegaly, lymphadenopathy, dwarfism, impaired vision and hearing, and bony fractures and deformities.

Diagnosis is confirmed by radiology which shows remarkably increased density of the skeleton with vertical striations of long bones and transverse bands in shafts, and soft tissue opacities due to calcification. This radiologic picture needs to be differentiated from that seen in fluorosis, lead poisoning and idiopathic hypercalcemia.

No specific treatment is indicated. Yet, prognosis is fairly good.

OSTEOCHONDRITIS

The term refers to a group of noninfective and noninflammatory bony lesions in which a vascular disturbance in epiphyses or ossifying centers appears to be the likely cause (Table 41.1).

Table 41.1: Important osteochondritis

<i>Osteochondritis</i>	<i>Bone involved</i>
Perthes' disease	Upper femoral epiphysis
Johannesson-Larsen disease	Patella
Osgood-Schlatter disease	Tibial tubercle
Scheuermann disease	Vertebral bodies
Kienboch disease	Lunate
Sever disease	Calcaneum
Kohler disease	Tarsal navicular

Perthes' disease is an osteochondritis secondary to a self-limiting avascular necrosis (AVN) of the head of the femur and causing painful limp in children aged 5-10 years. Major differential diagnosis is tuberculosis of the hip joint though bilateral disease needs to be differentiated from congenital hypothyroidism, sickle cell anemia, mucopolysaccharidosis and multiple epiphyseal dysplasia. Orthopedic treatment is osteotomy (femoral or innominate) for improvement of containment of head in acetabulum.

LIMB LENGTH DISCREPANCY

Etiology

Table 41.2 lists the important causes of limb (usually leg) length discrepancy.

Table 41.2: Leading causes of limb (usually leg) length discrepancy

<i>Congenital</i> Developmental dysplasia of the hip, hemiatrophy / hemihypertrophy, congenital skeletal limb deficiency (phocomelia), coxa vara
<i>Developmental</i> Perthes' disease
<i>Neuromuscular</i> Poliomyelitis, hemiplegic cerebral palsy
<i>Infections</i> Acute pyogenic osteomyelitis
<i>Trauma</i> Premature epiphyseal closure following physical injury, malunion of fracture with gross overlapping, angulation and shortening, overgrowth

Evaluation

Determination of bone age is important for a relatively accurate assessment of remaining growth of the affected limb. The ultimate discrepancy at maturity can be determined from scanographic and bone age data employing one of the *growth remaining tables*, the most widely used being *Moseley straight line graph*. In addition, radiographic evaluation using orthoroentgenogram, scanogram and CT scan can be done.

Treatment

A shortening between 1 cm to 2.5 cm needs compensatory shoes with raised heel and sole.

For a shortening exceeding 15 cm, an extension prosthesis is the choice. In cases with a shortening varying between 3 cm and 15 cm, surgical equalization by osteotomy and distraction is today preferred over periosteal stripping which has much less predictability.

CHILD ABUSE AND NEGLECT (CAN)

Refer Chapter 42 (Miscellaneous and Unclassified Issues).

INFECTIONS/INFLAMMATIONS OF BONES AND JOINTS

ACUTE SEPTIC (PYOGENIC) ARTHRITIS

Etiopathogenesis

5 It may result from a host of pathogens. *Staph. aureus* (the most predominant), *Streptococcus*, *Pneumococcus*, *Gonococcus*, *Meningococcus*, *E. coli* and *H. influenzae* or as a part of acute infectious disease such as septicemia, enteric fever, pneumonia or influenza.

Route of entry of pathogens may be hematogenous from a primary focus, an infection in the joint *per se* (especially in case of intraarticular metaphysis as in hip and shoulder joints) or a puncture wound.

Clinical Features

Joints involved in order of frequency are knee, hip, elbow and shoulder. Usual presenting features are painful swollen joint with marked restriction of movements of the limb which is held in a position of flexion.

Diagnosis

In the early stage, X-ray of the affected joint may be normal or show a soft tissue swelling and increase in the joint space compared to the corresponding other joint. In later stage, there is definite diminution in joint space, destruction of cartilage, new bone formation and, finally, full bony ankylosis.

Aspirated fluid from the affected joint is consistent with features of pyogenic arthritis.

Differential diagnosis is mainly from acute osteomyelitis, acute rheumatic fever, acute rheumatoid arthritis and tuberculous arthritis.

Treatment

It consists in promptly administering appropriate broadspectrum antibiotics, including penicillinase-resistant, parenterally, joint aspiration, open drainage of the joint (arthrotomy) and immobilization of the limb by POP or traction. As soon as pain and fever subside and the joint appears quiescent, mobilization of the joint should be initiated.

OSTEOMYELITIS

Etiopathogenesis

The commonest etiologic agent is *Staphylococcus aureus*. Additional organisms are group B streptococci and coliforms in neonates, *H. influenzae type B* in infants and children under 5 years (more so under 3 years), *Pseudomonas aeruginosa* in osteomyelitis following puncture wound of the foot, *Salmonella spp* in osteomyelitis associated with sickle-cell disease, *Serratia spp* and *Aspergillus spp* in chronic osteomyelitis, anaerobes in osteomyelitis complicating infections following injury, human bite and decubitus ulcers, and fungal infections in osteomyelitis in penetrating wounds, in immuno-suppression and in neonates.

Acute osteomyelitis occurs as a result of hematogenous spread from a distant focus such as umbilicus, skin or throat, or direct spread from a nearby septic focus. Metaphysis is the most susceptible site on account of sluggish circulation and lack of phagocytic cells. Following bacterial infection, an inflammatory exudate collects under pressure in bone marrow and cortex. What ensues is ischemic infarction of the bone because of septic thrombosis and compromised vascular supply. Formation of periosteal pus elevates the intact periosteum. Serious depletion of blood supply leads to infarction and necrosis of cortical bone, the so-called "sequestrum". The subperiosteal abscess may even burst through the periosteum into the soft tissues and skin *via* sinus tracts. Simultaneously, inflammatory reaction in the overlying soft tissues leads to signs of inflammation near the location of osteomyelitis. In infants, inflammatory process has a tendency to extend to epiphysis as well, causing septic arthritis.

Chronic osteomyelitis follows inadequately treated acute osteomyelitis. It has ischemia and poor host defenses as compared to the high virulence of the pathogens, more so in the presence of a foreign body or necrotic tissue, as predisposing factors.

Clinical Features

Acute osteomyelitis manifests with fever, toxemia, pain, local signs of inflammation (warmth, tenderness and swelling), and pseudoparalysis. In neonates, there is a greater tendency to have multifocal disease with involvement of the adjacent joints. Often, signs are nonspecific or few. Vertebral osteomyelitis is characterized by referred pain to abdomen, thigh or hip.

Chronic osteomyelitis is characterized by local manifestations including sinus tract. The discharging sinus is fixed to the underlying bone. Adjacent joints may be stiff because of secondary arthritis.

Diagnosis

Isolation of the etiologic agent by blood culture, or culture of material obtained by bone aspiration or biopsy is the most important diagnostic tool. Culture must include anaerobes.

Plain X-ray shows characteristic changes in the form of periosteal elevation, subperiosteal new bone formation, rarefaction of bone in second week only (usually 10 to 14 days). In the first week, a deep soft tissue swelling with obscuring of fat lines between muscles do suggest osteomyelitis.

A 3-phase bone scan, radionuclide scan, CT scan or MRI may be reserved for difficult case.

Other investigations include acute phase reactions like TLC/DLC, ESR and CRP, and tests for tuberculosis in case tuberculous etiology is on the card.

Differential Diagnosis

Osteomyelitis needs to be differentiated from a multitude of conditions, say cellulitis, abscess, bursitis, pyomyositis, septic arthritis, hemophilia, acute rheumatism, trauma, diskitis, malignancy, etc.

Treatment

As soon as a clinical diagnosis of acute osteomyelitis is made, intravenous antibiotic therapy must be started. A strong antistaphylococcal antibiotic

(cloxacillin, nafcillin, oxacillin, vancomycin in case of organisms resistant to former agents) should be administered. In neonates, it should be supplemented with an aminoglycoside (gentamicin) to cover gram-negative organisms. Alternatively, cefotaxime may be given.

In children under 5 years, especially when osteomyelitis is accompanied by septic arthritis suggesting *H. influenzae* type B infection, antistaphylococcal antibiotic should be given in combination with an anti-*H. influenzae* type B antibiotic (chloramphenicol). Alternatively, cephalosporins such as cefuroxime or ceftriaxone which cover both these organisms may be employed.

In osteomyelitis following puncture wound of foot, antistaphylococcal penicillin should be supplemented with antipseudomonal penicillin (ceftazidime) and an aminoglycoside.

Osteomyelitis with sickle-cell disease should be treated with antistaphylococcal antibiotic with a cephalosporine (cefatoxime) or an aminoglycoside.

For anaerobic organisms, the recommended drug is clindamycin.

In uncomplicated cases showing encouraging response, IV antibiotic should be given for 6 weeks followed by oral antibiotics in high doses for 12 weeks.

Adjuvant therapy includes analgesic/antiinflammatory agents, nutrition, hydration and immobilization.

TUBERCULOSIS OF BONES AND JOINTS

Tuberculous involvement of bones and joints usually occurs following hematogenous spread from the primary focus which is generally in the lungs.

In tuberculous osteomyelitis, the bones frequently involved are short long bones (metacarpals, metatarsals, phalanges) and short bones (calcaneum, carpals). Involvement of long bones is very infrequent.

In tuberculous arthritis, commonly affected joints are hip, knee and elbow, the infection being either synovial or osseous. Tuberculosis of spine (Pott's spine) usually involves thoracolumbar spine because of excessive mobility of the region and proximity of cisterna chyli which may bring tuberculous foci from the mesenteric lymph nodes. Site of vertebral involvement in order of frequency is metaphyseal, central, appendiceal and anterior. Most common deformity is kyphosis (knuckle, angular or rounded).

Locally a prevertebral or paravertebral abscess may be present. Or, else, it may present elsewhere (psoas abscess, lumbar abscess, chest wall abscess, gluteal abscess). For paraplegia secondary to Pott's spine, see Chapter 23 (Pediatric Neurology).

Besides ATT (Chapter 21), orthopedic treatment consists in immobilization, drainage of the abscess (preferably by surgical procedures like costotransversectomy, anterolateral decompression, radical operation or laminectomy) and arthrodesis (fusion) of the joint.

TRANSIENT SYNOVITIS OF THE HIP

(Observation Hip)

It is sterile inflammation and effusion of the hip joint, often preceding septic arthritis or Perthes' disease, characterized by painful hip with restriction of movements (especially internal rotation). Unlike septic arthritis, it does not cause toxemia. Diagnosis is from ultrasonography and, at times, aspiration of the hip joint. Treatment is immobilization of the joint. Within a week, it resolves.

5

RHEUMATOID ARTHRITIS

Refer Chapter 30 (Pediatric Collagenosis).

BONE TUMORS

Table 41.3 presents classification of benign growths and true tumors in relation to bones.

Table 41.3: Classification of bone growths/tumors

Benign Tumor-like Lesions

Reactive: Benign osteoblastoma, osteoid osteoma, nonosteogenic fibroma

Cystic: Solitary cyst, aneurysmal cyst

Hamartoma: Osteoma, osteochondroma (solitary exostosis), enchondroma

True Tumors

Primary: Osteosarcoma, chondroblastoma, chondrosarcoma, chondromyxoid fibroma, fibrosarcoma, malignant fibrous histiocytoma, plasma cell myeloma, Ewing tumor, lymphomas, osteoclastoma

Secondary: From primary malignancy of other sites

PEDIATRIC SPORTS MEDICINE

Participation in games and sports is vital for physical fitness, psychosocial development, decision-making, self-confidence and overall health and personality of

the child. At times and in some children, specific advice from the pediatrician becomes mandatory regarding the magnitude of restriction, type of recommended sport activity, and fitness for return to normal activity and participation in sports.

Indications for Restriction

The pediatrician must use a balanced restraint in advancing advice for restriction of sports activity. The major indications for such a restriction are:

1. A definite need, e.g. fracture, major illness in which physical exercise may worsen the patient's condition.
2. A relative need, e.g. atlantoaxial instability in which contact (collision) sports are not permitted but non-contact sports are allowed.

Categorization of Sports

- i. *Contact/Collision:* Hockey (both field and ice), football, wrestling, boxing, judo, karate.
- ii. *Limited Contact/Collision:* Basketball, baseball, gymnastic, skating (both roller and ice), squash, handball, volleyball, skiing, horseback riding, bicycling, driving, high jump.
- iii. *Noncontact/Strenuous:* Swimming, running, lawn tennis, weight lifting, aerobic dancing, discus, javelin, shotput.
- iv. *Noncontact/Moderately Strenuous:* Badminton, table tennis.
- v. *Noncontact/Nonstrenuous:* Archery, golf, riflery.

Areas of Concern

These are categorized as under:

- i. *Orthopedic* Knee or ankle injury, subluxing patella, scoliosis, cervical spine abnormality, chondromalacia patella.
- ii. *CVS* Murmur, hypertension, rheumatic heart disease, congenital heart disease, arrhythmias.
- iii. *Pulmonary* Exerciseinduced asthma, obstructive lung disease.
- iv. *Anatomic* Absence of eye, kidney, testis, organomegaly.
- v. *Hematologic* Anemias (including thalassemia major and sickle cell disease, bleeding disorder.
- vi. *Dermatologic* Contagious disease like herpes simplex, chickenpox, etc.
- vii. *Neurologic* Mental retardation, seizures, syncope, repeated head injury.

Disqualifications and Limitations

Every child has a right to participate in sports. The parents need to be advised by the attending doctor with this fundamental principle in mind. Too stringent and confining restrictions often do “harm” to the child, especially to his psyche. Attempts must always be made to find out appropriate alternatives for an unavoidable restriction. For instance, a child may have to be “off” from strenuous and contact sport such as boxing for an unavoidable reason. But, then, he can be shifted to noncontact but moderately strenuous badminton.

Pediatric Evaluation

Every child ought to have a good pediatric checkup before he takes up a regular sport. The objective of such a preparticipation health examination is to identify specific conditions which are likely to place the child at risk for injury, exacerbation of his condition, or even death. Such an examination needs to be conducted every 3 to 4 years or as and when there is a change in the level of competition, e.g. change from a junior group to a senior group.

Pediatric examination should also include psychologic assessment with a spotlight on determining attitudes and behaviors pointing to risks of “burnout” or “overuse” injuries. Pediatrician’s advice for rest, rehabilitation, and returning to the field after a reasonable gap of time must be sought.

The Pediatric Sports Medicine Program and the Pediatrician’s Responsibilities

1. To assess the frequency, type and duration of physical activities during health supervision visit.
2. To develop the capacity to perform body composition analysis by skinfold testing. Obese children who require to lose weight should be monitored.
3. To teach the importance of regular physical activity (moderate to vigorous) as a means of safeguarding against illness during adulthood.
4. To encourage parents to serve as role models by participating in regular physical activity along with the child.
5. To work with community schools, to support daily physical education in these schools and to promote

moderate to vigorous activity tasks in physical education classes.

PEDIATRIC FRACTURES

Fractures account for 1/6th of pediatric injuries, the common ones being clavicular, distal radius and ulna, humerus, phalangeal, lateral malleolar, metatarsal, toe phalanges and toddler fractures.

Special Features

Their distinct peculiarities compared to adult fractures on account of major anatomic, physiologic and biochemical differences.

Fracture remodelling occurs by a combined action of periosteal reabsorption and new bone formation.

Overgrowth by 1-3 cm, especially in femur, in children under 10 years warrants bayonet apposition.

Angular deformities, shortening or both occur because of closure of physes.

Fracture healing is more rapid owing to high growth potential and thicker and more active periosteum.

Patterns

These may be complete (most common), greenstick, buckle (torus), plastic deformation (bend), and epiphyseal which are further subdivided into five groups for prognostic predictions.

Management Highlights

Immobilization (simple, splint, POP cast, figure of eight strap in clavicular fractures) is central to treatment of pediatric fractures. A close reduction may be warranted in some cases.

Indications for *operative stabilization* include:

- Displaced epiphyseal fractures
- Displaced intra-articular fractures
- Unstable fractures
- Fractures in the multiply injured child
- Open fractures.

FURTHER READING

Articles/ Chapters

1. Hergenroeder AC, Chorley JN. Sports medicine. In Kliegman RM, Behrman RE, Jenson HB, Stanton BF (Eds): *Nelson Textbook of Pediatrics* (18th edn). Philadelphia: Saunders 2008;2302.

2. Kasser JR. Orthopedic problems. In Cloherty JP, Stark AR (Eds): *Manual of Neonatal Care* (4th edn). Philadelphia: Lippincott Raven 1998;541-544.
3. Schwend RM, Geiger J. Outpatient pediatric orthopedics: common and important conditions. *Pediatr Clin North Am* 1998;45:943-971.
4. Sharma S, Singh M. Orthopedic problems of the neonate. In Gupte S (Ed): *Recent Advances in Pediatrics (Special Vol. 5: Neonatology- 2)*. New Delhi: Jaypee 2000:347-357.
5. Singh T. Pediatric sports medicine. In Gupte S (Ed): *Recent Advances in Pediatrics- 6*, New Delhi: Jaypee 1996;41.

Books/Monographs

1. Tacholjian M. *Pediatric Orthopedics*. Philadelphia: JB Lippincott 1990.
2. Morrissy RT. *Lovell and Winter's Pediatric Orthopedics*. Philadelphia: JB Lippincott 1990.

PART SIX



Miscellaneous and Unclassified Issues



Miscellaneous and Unclassified Pediatric Issues

Suraj Gupte

CHILD ADOPTION

The term, *adoption*, is employed to an act of affiliation by virtue of which a child is removed from the biological parents and is placed in the adoptive family. The adoptive parents become responsible for his care and welfare.

Why Adoption?

The most common reason for adoption is “a viable alternative means for attaining parenthood by a childless couple”. Other reasons could be eagerness of a couple to provide home to a homeless child, a noncurable genetic disorder in couple’s biologic child, a desire for a child of the other sex, advanced age of the mother/parents. The parents are expected to adopt a child because they love to take his care and not because they see a support in him for their old age.

Most children that are available for adoption come from young unwed mothers who fail to keep such children with them because of the stigma attached to out-of-wedlock issues. Remaining reasons for giving the child away for adoption include desertion by one parent, death of a parent, birth of an unwanted child (usually a girl or a handicapped child).

Source of Adoption: A Relative or An Agency?

Though most often adoption is restricted to the couple’s relatives, this is, by no means the recommend means of adoption. Neither taking resort to private adoptions through hospitals and medical practitioners

without completing the legal formalities is in order. Such an adoption can never guarantee confidentiality. Today, moreover, biologic parents can anytime contest the adoptive parents right to continue with the custody of the child.

The best way to adopt a child is through the reputed adoption agencies, children’s homes and other institutions that have children for adoption. These agencies make available to the adopting couple the requisite details about the exact procedure for adoption. The agencies make sure that the adopted child is smoothly placed with the adopting parents.

Adoption Laws

The well-known *Hindu Adoption and Maintenance Act 1956* governs adoption among the majority community in India. In case of minority communities whose personal laws fail to permit adoption, the parents can only be guardians to the adopted children. Here, the adopted child does not automatically get the status of a biologic child. Some other notable features of the adoption law are summarized in Table 42.1.

The adoption laws have been criticized for some glaring deficiencies which leave a room for violation of the laws by various quarters including the Apex Court. For instance, a married Hindu woman is not entitled to adopt a child notwithstanding a consent from her husband. Secondly, an adult orphan cannot be adopted because he has no guardian. Thirdly, an adopted child has got to break all relations with biologic parents and can never return to them even when he opts for this course as he grows up.

Table 42.1: Highlights of the adoption law

- A. In respect of the child**
- A prospective child for adoption must not have completed 15 years.
 - An adopted child cannot be readopted by another person even though the latter is the child's natural (biologic) parent.
 - A married child cannot be adopted.
- B. In respect of the adopting parent**
- A Hindu cannot adopt more than one male or a female child.
 - The adopting parent must be a "major" (has completed age of 18 years) and of sound mind.
 - It is obligatory for a married Hindu male to obtain consent of his wife for adopting a child.
 - A married Hindu woman cannot adopt even with the consent of her husband.
- C. In respect of parent who give in adoption**
- The father cannot give his child in adoption without the consent of the mother.
 - The mother of an illegitimate child is entitled to give the child for adoption.
- D. In respect of the guardian**
- The guardian is entitled to give the child in adoption under special circumstances such as when the parentage is not known, e.g. abandoned children in hospital, nursing home or refugee camp.

Adoption and the Pediatrician

6

The role of the pediatrician both before and after adoption remains important. He must encourage adoption from an approved agency only. He should appropriately assess the psychosocial settings of the adopting couple. Secondly, he should provide adequate safeguard to the adopting couple by providing correct information about the health status of the child to be adopted. Thirdly, he should make available to the family benefit of his advice for the emotional problems of the adopted child as a consequence of overindulgence of the parents.

CHILD ABUSE AND NEGLECT (CAN) (Nonaccidental Injury, Battered Baby Syndrome)

The term refers to maltreatment (physical, sexual or emotional) of children by the parents, guardians or other caretakers. The entity has other semantics such as *nonaccidental injury*, *battered baby syndrome*, etc.

Almost 75% of the CAN recognized in hospitals is physical, 20% sexual and 5% emotional/nutritional deprivation leading to nonorganic failure to thrive.

Etiology

Battering is generally encountered in unhappy homes. These families have gross stresses such as monetary instability, unwanted pregnancy, arrival of a more precious newborn and mental illness. The last-named applies to both, parents as well as babies. The latter may be mentally-retarded social rejects.

A substantial proportion of the parents who batter their children are the ones who had experienced physical or other abuse as children. They are neither criminals nor psychopaths but just unhappy adults living under tremendous stress and strain.

The child most likely to be battered has the following predispositions:

- Negativism
- Difficult temperament
- Enuresis
- Soiling
- Habitual crying
- Spilling
- Mental subnormality

It has been suggested that child labor should be regarded as a form of child abuse.

A peculiar form of CAN, the so-called *Munchausen syndrome by proxy*, is characterized by a fabricated or falsified illness courtesy one of the parents, usually the mother who is connected with the medical profession (say a nurse). The following 4 criteria must be satisfied for this diagnosis:

1. Illness in a child is fabricated by a parent
2. The child is presented for medical assessment and care, usually persistently, often resulting in a multitude of medical procedures;
3. The perpetrator denies the etiology of the child's illness; and
4. Acute manifestations of illness disappear when the child is separated from the perpetrator, invariably the mother.

Notably in a family where parental behavior of fabricating illness is evident, the risk of a variety of abuses and neglect in the siblings is high.

Clinical Features

Physical abuse Usually a battered baby is less than one year of age, sometime less than 4 years but uncommonly beyond this age.

He is brought with painful swellings, restriction of movements and some contusions over areas corres-

ponding to the ends of the long bones. The arms may reveal finger and thumb impressions of the abuser. Thrashing with a belt, stick or ruler may leave lash marks on the body. Bite marks are seen as crescent-shaped bruises. Slap marks are seen as two or three parallel bruises, usually over the cheeks. The neck may reveal choke marks. Strings or ropes tied around ankle or wrists leave circumscribed marks. The presence of "black eye" and contusions over face or sides of the head often clicks the diagnosis.

Burn marks (Fig. 42.1) may be characteristic of the modus operandi. Punched out circular lesions of nearly the same size suggest cigarette burns. A circular type of burn involving only the buttocks or thighs and waist points to hot water injury.

Physical abuse may result in as dangerous an injury as subdural hematoma, manifesting with convulsions and coma.

A blow injury over the abdomen may cause tearing/rupturing of liver or spleen.

Clinical manifestations out of proportion and/ or in discrepancy with parent's story, abnormal attitude of parents and a gap of some days between onset of symptoms and signs and parents seeking medical advice should arouse suspicion.



Fig. 42.1: CAN: Note the old scalds in burns inflicted by battering father in a mentally challenged girl

Sexual abuse Molestation, intercourse and rape are the three types of sexual abuse seen in practice. Skin, mouth, rectum and external genitalia may show evidence of trauma. A hymenal opening of over 5 mm should be considered abnormal in a prepubertal girl. *Pedophilia* refers to sexual abuse (attack) on children under 10 years of age.

Nonorganic failure-to-thrive (FTT) An unwanted child may be deprived of emotional stimulus and/or nutrition. Manifestations include signs of nutritional deficiencies, and stark hygienic neglect (nappy rash, impetigo, scabies, unwa-shed skin, uncut nails, dirty clothing).

Diagnosis

Physical abuse Whenever battering is suspected a complete radiologic survey of the skeleton should be done. Soon after injury, X-ray shows soft tissue swelling and detachment of thin bone fragments from the metaphysis. Deposition of new bone in and beneath stripped periosteum in several days may lead to visible hyperostosis. At times, direct injury of epiphyseal cartilage can cause shortening of shaft with cupping of the **shortened** end. Linear fractures of skull and fractures of ribs may also be present. Subdural hematoma is found in some cases. In such cases, presence of retinal hemorrhages should be looked for.

Differential diagnosis is from scurvy, leukemia, Caffey disease, suppurative arthritis, congenital syphilis, osteogenesis imperfecta, etc. Lack of familiarity with CAN may lead to initiation of irrelevant, unnecessary and expensive investigations.

Sexual abuse Since there may be no definite physical evidence of sexual abuse, physician should employ dolls and pictures to clarify body parts and to build up the story rung by rung.

Nonorganic failure-to-thrive (FTT) Dramatic improvement following hospitalization and feeding trial establishes the diagnosis.

Treatment

Child battering always indicates serious underlying family disturbances. The handling of the problem, therefore, needs clinical manifestations out of proportion and/or in discrepancy with parent's story, abnormal attitude of parents assistance from a

psychiatrist, a social worker and sometimes the police. It is a "must" to hospitalize such a child, not for sheer diagnosis but for his safety as well. Infrequently, the abused child may need to be permanently kept away from his home if parents are guilty of dangerously aggressive tendencies.

INFANTILE TREMOR SYNDROME (ITS)

An obscure entity, characterized by tremors, anemia and regression of milestones in Indian infants and young children, is termed *infantile tremor syndrome*. It was first described in 1957 by Dikshit who called it *nutritional dystrophy and anemia*. In the subsequent years, it has been reported from various parts of the country, more so from south India, Jabalpur, Lucknow, Punjab, Chan-digarh, Simla and Jammu. A few cases were seen among Bangladesh refugees during 1971-72.

"Infantile meningoencephalitis", "tremor syndrome", "nutritional tremor syndrome", "syndrome of tremors, mental regression and anemia in infants", and "syndrome of tremors in infants" rank among the other nomenclatures employed for this disease in the literature.

Epidemiologic Considerations

6 *Incidence* It accounts for 1 to 2% of pediatric admissions in the hospitals that have started recognizing this condition. In our experience, it formed 1.9% of the admissions to the pediatric inpatient department of the Snowdon Hospital, Simla, during 1971-74. At Jammu, recently, at one time, 6 of our 200 hospitalized children happened to suffer from infantile tremor syndrome. This may be little exceptional. But, then, nearly always we have at least one or two such patient around.

Age The vast majority of the cases fall in 6 months to 1½ years age group. A few children may be up to 2 years of age. It is unusual to see cases outside this age range. This author has seen a 3 years old and another aged 5 years with characteristic features of this syndrome.

Sex Males suffer more frequently than females.

Nutritional background These infants come from poor families. Most of them are breastfed and have concomitant malnutrition, especially anemia, though they look plump.

Seasonal variation The peak incidence is noticed during summer.

Etiology

Three hypotheses have been put forward:

1. *Nutritional* Earlier reports suggested that ITS appeared to result from megaloblastic anemia which responded well to vitamin B₁₂. This hypothesis received support from the following:

- Megaloblastic anemia was always associated with ITS.
- These infants had low levels of vitamin B₁₂.
- The administration of vitamin B₁₂ to these patients led to regression of the major manifestations of ITS.
- The syndrome resembled cases of megaloblastic anemia with neurologic manifestations seen in Italy and America.

During recent past, it has been observed that not all infants with ITS suffer from megaloblastic anemia. In fact, some do not have it at all while others show dimorphic anemia. There are cases seen by us as well as others who have purely iron-deficiency anemia. Moreover, even those suffering from megaloblastic anemia may need folic acid alone or in combination with vitamin B₁₂ for adequate response. At the same time, infants without megaloblastic anemia, may not need vitamin B₁₂ and folic acid and yet evince cure with correction of iron-deficiency anemia and improvement in the overall nutritional status.

Even magnesium deficiency has been blamed as another possible etiologic factor. In fact, some workers have found reduced magnesium in CSF of infants suffering from ITS. Tremors and rigidity, among other neurologic manifestations, are known to result from such deficiency. How far magnesium lack contributes to the development of ITS is difficult to say.

Zinc reduction in body tissues and fluids is documented by us and others. In view of presence of anemia, pigmentation, hair changes, tremors and mental lethargy, role of zinc deficiency in its etiology appears quite probable.

2. *Viral encephalitic* It has been suggested that ITS may well be a sort of viral encephalitis. Acute onset of

tremors and their occurrence following intravenous drip or blood transfusion in certain instances are often cited in support of this hypothesis. However, no virus has so far been isolated. Also, absence of any consistent CSF change and course of illness do not lend support to this speculation.

3. *Degenerative* Recently, brain biopsies and pneumoencephalographic studies have revealed cortical atrophy in majority of the cases investigated in Lucknow and Patiala. The Patiala workers have found patchy fibrosis of muscle tissue and demyelination and swelling of the myelin sheath of nerves. Similar brain, muscle and nerve alterations have been seen by us on autopsy material.

Clinical Features

A typical infant with ITS is plump (though underweight for his chronologic age), apathetic and anemic with hair and skin changes (Fig. 42.2).

Hair is light-colored (*hypochromotrichia*) and sparse as in kwashiorkor. There is a brownish *reticular pigmentation of skin*. This is more remarkable over dorsal aspect of hands (especially over terminal phalanges),



Fig. 42.2: *Infantile tremor syndrome.* Note the hair changes, vacant look, chubby appearance despite malnutrition, and tremors

feet, knees, ankles, axillae, buttocks, lower abdomen and medial aspect of thighs. There is history of *regression* of motor and mental milestones in the recent past. The onset of tremors is preceded or accompanied by some stress in the form of acute lower respiratory infection (ALRI) or gastroenteritis. These tremors usually disappear during sleep in most cases; in others their intensity remarkably diminishes.

Tremors resemble those seen in parkinsonism and appear to originate from cortical neurons. These may be generalized but are more prominent in distal parts of the limbs (especially upper limbs), head, face and tongue. Even trunk may be involved. Some infants produce *tremulous cry* like that of a lamb. They keep tossing their head from side to side with the saliva drooling from mouth and have dull, expressionless look. Mental and motor development is impaired in all.

Hypotonia, particularly of thigh muscles, is common though hypertonia may be found in an occasional patient.

Anemia is generally moderate and may be macrocytic/megaloblastic, normocytic-normochromic, iron-deficiency or dimorphic type.

Incidence of variable *nutritional deficiencies* and superadded infestations/infections, including tuberculosis, is high.

Incomplete forms, say the so-called *pretremor state*, with all the features of the syndrome minus tremors, are also known. We have observed development of tremors in such untreated infants in due course.

Course

Three phases are recognized, namely pretremor, tremor and post-tremor.

Pretremor (prodromal) phase is characterized by regression of attained milestones, motor and/or mental slowness with vacant expressionless facies, anemia, pigmentation, hair changes, plumpy look despite malnutrition, and drooling. Tremors are absent.

Tremor or classical phase is characterized by appearance of tremors on top of clinical features of pretremor state. Initially, the tremors are seen only on crying or feeding and involve fingers, face and tongue. Subsequently, these become generalized.

Post-tremor or recovery phase is characterized by regression of tremors and other features of the syndrome. The mental dullness continues for several months.

Diagnosis

The familiarity with the clinical picture, described above, together with high index of suspicion should enable a clinician to recognize an infant suffering from this syndrome.

Investigations should be aimed at finding the extent and morphologic type of anemia, determining the nutritional status, and detecting coexisting infections and infestations.

EEG in cases with gross tremors shows changes that are no different from those encountered in seizure disorder. The changes are in the form of high voltage sharp waves and spikes with a slow background activity of delta range which are by and large consistent with those encountered in advanced malnutrition. Interestingly, the EEG changes do not revert to normal after the tremors are fully controlled. We are yet to ascertain if these show disappearance during a longer follow-up.

Treatment

6 Since anemia and malnutrition are always present (though cause and effect relationship between these and ITS is not as yet definitely established), it is desirable to treat these as discussed elsewhere in this book. We do not favor administration of vitamin B₁₂ to every child with ITS. Zinc in therapeutic doses is strongly recommended.

Administration of phenobarbital orally in the initial stage is advantageous. It reduces the intensity of tremors and may even control these, protects the child from continued exhaustion, and provides much needed psychologic relief to the worried parents. Furthermore, it may well help in cutting down the period required for control of tremors. Some workers have reported encouraging response to chlorpromazine, propranolol, carbamazepine, etc. (Box 42.1) in cases showing poor results with phenobarbital.

Along with these measures, the child should receive adequate treatment for his other associated problems like intestinal parasites, respiratory infection or tuberculosis.

Box 42.1: Drugs employed for controlling tremors

Drugs	Doses
Phenobarbital	3-5 mg/kg/day (O) in one or two doses
Chlorpromazine	2-3 mg/kg/day (O) in 3 divided doses
Carbamazepine	10-20 mg/kg/day (O) in 2 divided doses
Propranolol	0.1-1 mg/kg/day (O) in 3 divided doses

Prognosis

With the above measures, response is encouraging. As the nutritional status (including hemoglobin) improves, tremors gradually cease. This generally takes approximately 1 to 4 weeks. The children continue to be mentally dull and sluggish for quite some months to come.

EEG changes seen in advanced cases perhaps take much longer time to regress even though the tremors may be over.

ITS *per se* does not cause death. But, fatalities as a result of a coexisting illness are not uncommon.

SUDDEN INFANT DEATH SYNDROME (SIDS)

This term refers to the sudden, unexpected death of an apparently healthy infant, usually 2 to 3 months of age, who had been put to the bed without any suspicion of such an occurrence. A conventional autopsy fails to reveal the cause of death.

When an apparently healthy infant suffers from an episode in which his breathing ceases, cyanosis or pallor develops, and he becomes unresponsive but is successfully revived (resuscitated), the term, *apparent life-threatening event* (ALTE), is employed. This state is also called *near-miss* or *aborted SIDS*. In this state, there is a considerable risk of SIDS subsequently. In the event of a SIDS in a family, risk for the next or subsequent infant is 5 times higher than the usual risk.

Etiopathogenesis

Etiology remains obscure. Allergy to cow milk, enlargement of thymus, suffocation, deficiency of parathyroids or adrenals, hypernatremia and fulminant respiratory infection causing laryngeal obstruction and/or spasm figure among the large number of conditions/factors that are incriminated in its etiology. Such states as prolonged sleep, apnea, (associated with CNS disorders), vascular rings, familial prolongation

of QT interval (Ramano Ward and Jervell and Lange-Nielsen syndrome), accidental suffocation and child abuse and neglect (CAN) at times camouflage as SIDS. An abnormality of cardiorespiratory control, in which state of consciousness or CNS activity plays a modulating role, appears to be shared by all cases of true SIDS. Prone sleeping position is an important risk factor for SIDS.

Though the pathologic findings, taken in totality, suggest occurrence of hypoxia preceding the tragic event, autopsy shows no hyperplasia of the carotid bodies.

Diagnosis

In case of infants at risk (LBW, near-miss, or ALTE, siblings of SIDS cases), history should include information on physiologic handicaps before birth such as low Apgar score, abnormality in control of respiration, heart rate and temperature, and postnatal growth retardation. The parents must be questioned about the infant's feeding, medications, etc.

Physical examination should concentrate on infant's nutritional status, hydration, evidence of infection, CAN and neurologic handicaps. Respiratory system should be particularly evaluated. The infant needs to be observed while he is being fed. Investigations include:

- Blood analysis for glucose, sodium, potassium, calcium, phosphorus, magnesium, BUN, pH and blood-gas analysis
- Urinalysis
- Microbiologic tests
- ECG monitoring
- EEC
- Radiology: Barium swallow, chest X-ray, skeletal survey
- Esophageal pH studies
- 4 to 8 hours sleep studies

Currently, home monitoring technologies utilizing event recordings (respiratory pattern, heart rate, ECG, oxygenation) are being evaluated for prospective identification of risk of SIDS.

Treatment

The parents distressed with "guilt" feeling need to be assured that they were not the cause of the sudden death of the infant. They also need to be counselled on anticipatory guidance.

Use of caffeine and theophylline in apnea of prematurity and infancy may indirectly cut down the incidence of SIDS by improving respiratory pattern in these subjects.

PROGERIA (*Hutchinson-Gilford Syndrome, Plucked Bird Disease, Premature Senility*)

First described in 1886 by Hutchinson and Gilford, this is an extremely rare disorder (incidence 1 in 8 million) of unknown etiology though believed to be due to a genetic mutation. The characteristic features include infantilism, remarkable absence or diminution of subcutaneous fat, generalized alopecia (including missing eye-brows) and other manifestations of premature onset of senility (Fig. 42.3). Physical development in infancy is not significantly affected. Mental development is fair enough even when full-blown picture has developed.

Manifestations such as scleroderma, midfacial cyanosis and sculpted nose in early infancy may suggest the existence of the syndrome.

Median lifespan is around 13 years, death usually occurring from complications of cardiac or cerebral vascular disease.

Since the patients don't become sexually mature, parent-to-child transmission is not noticed.

Prognosis is usually fair. With persistence of lymphedema, subcutaneous tissue undergoes fibrotic changes. Some disfigurement may result.



Fig. 42.3: Progeria. Note the classical features of premature senility

CHRONIC FATIGUE SYNDROME

(Chronic Mononucleosis, Chronic Epstein-Barr Virus Infection, Immune Dysfunction Syndrome)

The term is applied to a state of easy fatigability accompanied by mild to moderate severe (debilitating) somatic symptoms.

Etiopathogenesis

Most pediatric subjects are adolescents, from both sexes with predominance of girls. The probable cause is an infection with replication of a known or new virus, including EBV, influenza virus, varicella, rubella as the inciting factor or nonspecific symptoms of a sore throat, fever, myalgia, diarrhea, etc.

Clinical Features

Chronic fatigue, varying from mild (subtle) to severe (debilitating) is the most predominant manifestation. This is often accompanied by deterioration in work or school performance, activities of daily living, exercise tolerance and interpersonal relationship. There may be a multitude of psychologic or neuropsychiatric complaints.

Physical examination hardly shows any abnormal findings.

Diagnosis

6 It is primarily by exclusion. It is important to have a psychologic evaluation for depression or anxiety. A complete blood count (CBC) with ESR, electrolytes, BUN, creatinine, serum alanine transaminase and aspartate transaminase, thyroid function test and urinalysis and stool microscopy are in order to exclude treatable diseases and to reassure the patient.

Treatment

Therapy of CFS is directed towards emotional support for the child and his parents/family and symptomatic measures.

Prognosis

CBC is an illness of a prolonged duration with waxing and waning of symptoms. There is no mortality though significant morbidity is a rule.

GROWING PAINS

This poorly understood entity is characterized by vague, deep aching bodily pains (nonarticular)

especially in calves, thighs, behind knees and occasionally in upper limbs. They may be mild or severe. In one-third cases, there may be associated headache and abdominal pain.

The pains are usually complained of towards the late evening and during night. Excessive fatigue and activity precipitate them.

The affected subjects usually belong to adolescent or preadolescent age group. In a significant proportion, there is a family history of such pains.

It is wrong to believe that the pains have any thing to do with physical growth, epiphyseal closure or hormonal changes. There is good deal of consensus that these may well be "a reaction to emotional disturbances, family pain predisposition or environmental stress". Excessive fatigue, nutritional deficiency state, and orthopedic defects may also contribute to their development.

The cornerstone of treatment is reassurance to the parents as well as the child that the problem is not organic and will be over in due course. Child's emotional needs must receive adequate attention. His general health may need improvement. Intestinal parasite(s), and anemia, if present, should be treated. Intolerable pains may warrant use of analgesics and local massage.

HISTIOCYTOSIS

The term is applied to a group of rare but severe disorders having significant proliferation or accumulation of cells of the monocyte-macrophage system of bone marrow origin.

Based on *histopathological* findings, a diagnostic classification is now available (Table 42.2).

The best known histiocytoses, eosinophilic granuloma, Hand-Schuller-Christian disease and Letterer-Siwe disease are included in Class I or Langerhans cell histiocytosis (LCH). Single or multiple bone lesions constitute hallmark of this histiocytosis, followed by skin lesions, exophthalmos, pituitary dysfunction and systemic manifestations like fever, weight loss, malaise, failure to thrive (FTT), irritability, anemia and thrombocytopenia secondary to bone marrow infiltration.

In Class II histiocytosis, manifestations include fever, weight loss and irritability, hepatosplenomegaly, aseptic meningitis, CSF invasion with macrophages, hyperlipidemia, hypofibrinogenemias, high he-

Table 42.2: Classification with prominent features of pediatric histiocytosis

<i>Classes</i>	<i>Histologic findings</i>	<i>Therapies</i>
Class I (Langerhans cell histiocytosis)	Langerhans cells with Birbeck granules	Local therapy for isolated lesions; chemotherapy
Class II (Familial erythrocytic lymphohistiocytosis; infection-associated hemophagocytic syndrome)	Normal reactive macrophages with prominent erythrophagocytosis	Chemotherapy; bone marrow transplantation
Class III (Malignant histiocytosis, acute monocytic leukemia)	Neoplastic proliferation of cells with characteristics of monocytes/macrophages or their precursors	Antineoplastic chemotherapy (including anthracyclin)

patric enzymes, very high levels of circulating soluble interleukin-2 receptors.

SARCOIDOSIS

This multisystem chronic granulomatous disorder of adults may infrequently be encountered in childhood.

Etiopathogenesis

The etiology is unknown. The granulomatous lesions may involve any organ or system though lung is the most commonly affected organ with parenchymal infiltrates, milary nodules and hilar and paratracheal lymphadenopathy. Typically a granuloma contain epithelioid cells, macrophages and giant cells in the center surrounded by a mixture of monocytes, lymphocytes and fibroblasts. A large proportion of the granulomas heals with complete preservation of the parenchyma. Nevertheless, some 20-25% of the lesions may end up as fibrotic scar tissue.

Clinical Features

These include chronic cough, easy fatigability, weight loss, anemia, lymphadenopathy and liver involvement. In older children, predominant manifestations may be ophthalmic (uveitis, iritis), dermatologic (maculopapular erythematous rash), and arthritic (large but painless effusions with minimal limitation of movements).

Diagnosis

Screening tests include a high ESR, eosinophilia, hyperproteinemia, hypercalcemia, hypercalciuria, a high ACE level and an intradermal injection of material from a sarcoid lesion (Kveim test).

Definitive diagnosis is from a biopsy of the granulomatous lesion.

Differential Diagnosis

It is from tuberculosis, pulmonary fungal infection (mycosis), lymphoma, inflammatory bowel disease and phlyctenular conjunctivitis.

Treatment

It is primarily symptomatic and supportive, at times warranting the use of steroids to suppress acute manifestations.

Prognosis

Those who fail to have spontaneous recovery, after months to years, may develop a progressive pulmonary disease and blindness.

SOME MINOR PROBLEMS OF THE NEWBORN, THE INFANT AND THE YOUNG CHILD

It is not infrequent for the parents to demonstrate undue anxiety over certain minor and basically benign problems. The attending doctor is required to provide proper guidance, reassurance and support to the parents, the mothers in particular, in allaying their concern and running from pillar to post. In this way, many unnecessary investigations and irrational therapies are avoided.

Neonatal Period

The benign problems that cause undue parental anxiety include physiologic jaundice, vomiting, transitional stools, constipation, toxic erythema, milia,

Mongolian spots, salmon patches, benign neonatal hemangiomas, harlequin color change, epstein pearls, sucking callosities, subconjunctival hemorrhages, physiologic mastitis, vaginal bleeding, natal teeth, cephalhematoma, caput succedaneum, umbilical hernia, hydrocele, hiccup, nasolacrimal duct blockade, physiologic phimosis and hymental tags. For details, see Chapter 17 (Neonatology).

Later Infancy and Childhood

Tongue-tie (Ankyloglossia)

A true tongue-tie is characterized by a very short frenulum which may manifest as a prominent midline groove at the tip of the tongue as a result of traction and/or failure on the part of the child to lick his upper lip. This is not only infrequent but also of no known functional significance. At worst, it may cause little dyslalia but never delayed speech. Only rarely it needs a surgical "cut" at 2 to 3 years of age.

In practice, tongue-tie is an overdiagnosed condition.

Delayed Speech

Frequently, the parents are worried about some delay in intelligible speech even though the child is normal in all other ways including hearing. The child is in need of a greater "sensory stimulation". Rather than talking to him in baby language and through gestures, they must spend more time in talking to him in clear speech. They need to be told that some normal children do take 3 years or longer to develop intelligible speech.

Eating Problem

Many otherwise normal and healthy-looking children (some may be rather thin), according to the parents, are fussy about their food habits. As a result, the mothers are always running after them with food bowls. They indulge in forcible feeding which is often resented by the child.

Such parents need to be told, after examination and certain limited investigations, that their "anxiety" about the child's disinclination to eat is rather not well founded. They must forthwith stop forcible feeding or any kind of cajoling or bribing in which they may be indulging to make the child eat in accordance with their wishes.

Bedwetting

Bedwetting is not pathologic until the age of 5 years. The parents should be made to understand this physiologic fact and unnecessary interventions, including investigations, avoided.

Umbilical Hernia

A proportion of the babies (say 1 in 4) have umbilical hernia (1 to 5 cm diameter) in association with diastasis recti (divertication of abdominal recti muscles) as a result of imperfect closure or weakness of the umbilical ring. Most such hernias disappear by 1 year, practically all by 3 to 5 years of age.

Strapping with a coin and a bandage is of no significance. Indications of surgery are as follows:

- Persistence beyond 3 to 5 years
- Rather than reduction, further increase in size after the age of 1 year
- Rarely when it gets strangulated.

Protuberant Abdomen

A protuberant abdomen, the so-called *pot-belly*, is a normal finding in the neonates as well as between 6 months to 3 years of age despite absence of any abnormality. The parents need to be reassured about its normalcy.

Irregular/Asymmetrical Skull

Some otherwise normal babies have an asymmetrical head. If craniosynostosis is excluded, the parents should be advised to properly position the head. With this, it assumes proper rounding by 3 to 4 months age.

Bowlegs (Genu Varum)/Knock Knees (Genu Valgum)

Physiologic bowlegs (a wide space between knees when feet are placed close together) is a normal observation in the first 2 years of life. If all else is fine, it warrants no treatment.

With the child's growth, during the third and fourth year, bowlegs are replaced by physiologic knock-knees which are more pronounced in obese children. Spontaneous improvement results during 4 to 10 years of age.

Flat Feet (*Pes Planovalgus*)

The flat feet, meaning increased area of ground contact with weight bearing because of imperfect longitudinal arch, are typically a common finding in normal children. It is normal for the arch to develop after toddler age. Physiologic flat foot, as a rule, is flexible. No treatment is needed.

MODERN IMAGING TECHNIQUES

During the last two decades, there has been a remarkable revolution in the diagnostic imaging techniques in the form of ultrasonography (US), computed tomography (CT) scan, magnetic resonance imaging (MRI) and modern nuclear medicine procedures. With these techniques, diagnostic precision has considerably enhanced, often allowing bypass of the exploratory techniques.

However, these new techniques are relatively expensive. Moreover, there is a growing tendency to use these as a convenient substitute for clinical workup, and simple investigations.

Ultrasonography

Pediatric ultrasonography is by and large the most frequently employed noninvasive imaging technique in childhood. It consists in the transducer translating the reflection of sound waves from interfaces in tissues into cross-sectional images of the normal and abnormal anatomy. There is no risk of ionising radiation.

Despite the presence of gas and bones, the well-known barriers to sound waves of high frequency and thus obstacles in the production of a useful image, it is possible to evaluate a child from head to foot by ultrasonography. For example, the anterior fontanel may serve as a “window” to the brain of an infant with hydrocephalus, intracranial anomalies, intracranial hemorrhage, or meningomyelocele. Even patent posterior fontanel can be employed to assess the intracranial structures. The postcraniotomy skull defects can also be used as “windows” for assessing the residual pathology or complications.

Cervical adenitis is a good ultrasound material. It can confirm the diagnosis, identify suppuration and guide the needle aspiration of pus.

Cardiac ultrasonography (echocardiography, Fig. 42.4) gives images of the highest precision and is

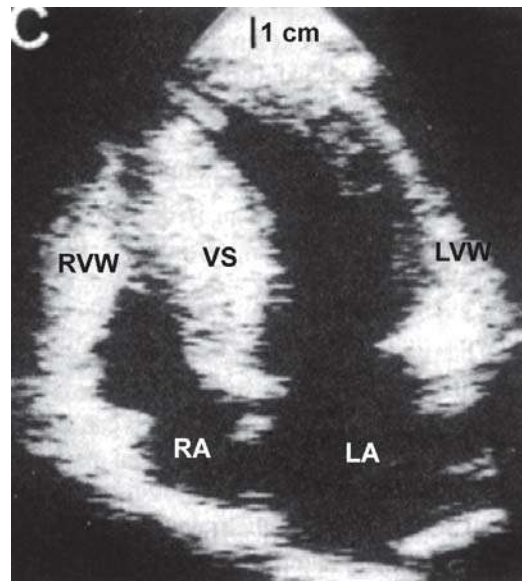

Fig. 42.4: 2-D echocardiography (apical 4-chamber view) showing gross hypertrophy of the interventricular septum (VS) that measures 4 cm as also remarkable hypertrophy of the free walls of the ventricles (LVW, RVW), each measuring 3 cm. *Diagnosis:* hypertrophic cardiomyopathy

a very useful procedure in the diagnosis of congenital and acquired heart diseases. It can also be employed to determine the effect of cardiotonic and cardiotoxic drugs as also performance of pericardiocentesis. M-mode echocardiography can identify movements of intracardiac structures, anatomy of valves and vegetations of endocarditis larger than 2 to 3 mm. It can also define cardiac function. Two-dimensional (2-D) echocardiography provides yet better images of cardiac anatomy. It is the imaging technique of choice for diagnosing structural heart disease. Doppler echocardiography provides physiologic information in addition to the anatomic findings. Pulsed Doppler and color Doppler echocardiography show the direction of flow in the vessels. Transesophageal echocardiography is best for obtaining clear view of vegetations of endocarditis and visualizing the atria, aortic root dissection, mitral valve disease and dysfunction of the prosthetic valve.

Abdominal ultrasonography (Fig. 42.5) has a unique place. Each and every solid abdominal organ is accessible by ultrasound. The most frequently scanned system in the abdomen is the urinary tract where urine, like other liquids, serves as a valuable

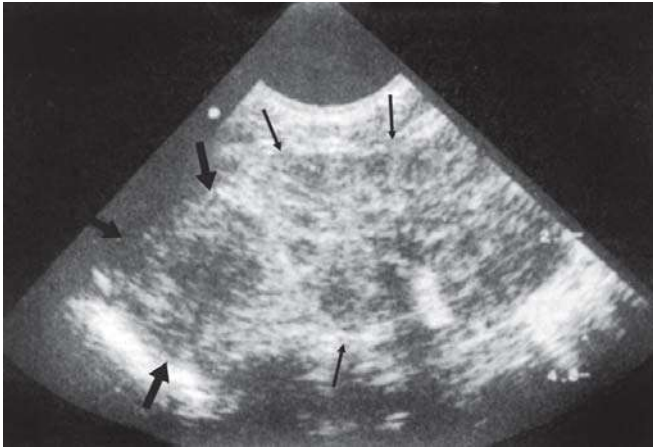

Fig. 42.5: *Ultrasound of abdomen.* Note the right adrenal hemorrhage (thick arrows) and displacement of the right kidney downward (thin arrows)

acoustic window. Some abdominal conditions usefully displayed by ultrasound are pyloric stenosis, intussusception, appendicitis, necrotizing enterocolitis, Wilms' tumor, scrotal mass, polycystic kidney, cholelithiasis, etc.

Recently, ultrasonography has come to occupy pride of place as the investigation of choice (superior to X-ray) in the diagnosis of congenital dislocation of the hip in neonates. The procedure bares open the effects of movements on the hip.

Prenatal ultrasonography is a promising technique for evaluation of the fetus with regard to growth and development as also presence of congenital malformations. If indicated, it can make intrauterine treatment feasible.

CT Scan

CT scan (Figs 42.6 and 42.7) consists in obtaining digitalized cross-sectional images by rapid bursts of X-rays during one revolution of both the tube and detectors which are on opposite sides of the child to be scanned. If IV injection of contrast material is made, the enhanced images can show opacified vessels and extracellular spaces. It can also distinguish among structures and permit deductions to be made about vascularity.

CT scan is particularly useful in evaluation of recent trauma to head and neck, hydrocephalus, in planning reconstructive craniofacial surgery, and detecting pulmonary metastases, bronchiectasis, and subtle interstitial disorders, abdominal trauma effects on viscera, Wilms' tumor, neuroblastoma, and in displaying tarsal coalition, femoral anteversion, and demonstration of adequate reduction of dislocated hip through a cast and tumorous destruction of cortical bone.

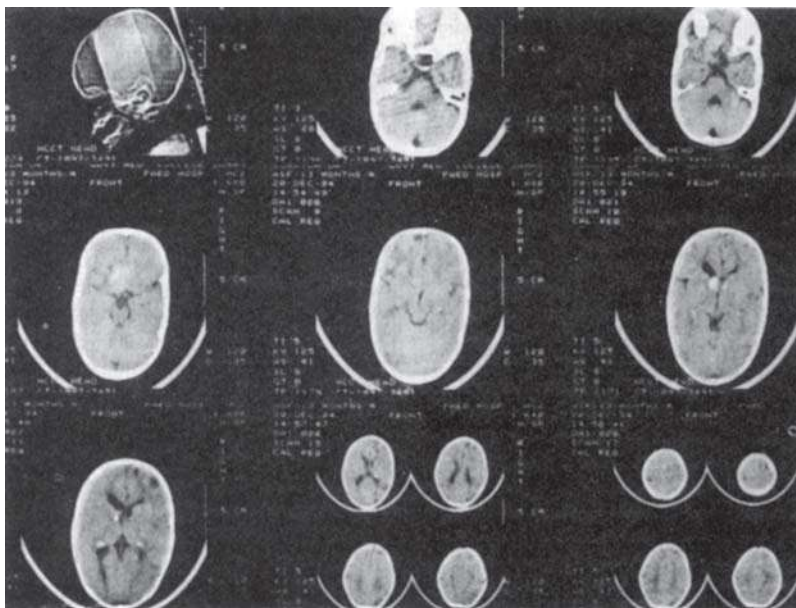

Fig. 42.6: *Computed tomography (CT) scan of skull.* Note the findings suggestive of multiple sclerosis and the large space-occupying lesion in the left frontal area

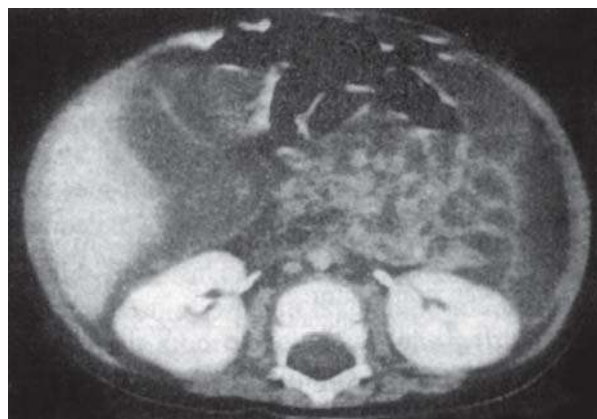

Fig. 42.7: CT scan abdomen. Note the gross thickness of the intestinal wall with retention of a large amount of fluid

In infants and children under 4 years age, sedation is usually needed for carrying out this procedure.

Magnetic Resonance Imaging (MRI)

Unlike CT scan, MRI yields images reflecting magnetic differences in body tissue rather than difference in X-ray absorption or acoustic reflection. The images are obtained in the sagittal, coronal and axial planes.

MRI is established as an excellent procedure for imaging fat, bone marrow, CSF, white and gray matter, blood vessels, ligaments, tendons, muscles and solid abdominal viscera. It is especially of value in displaying brain tumors and demyelinating diseases for which CT scan is less suitable. For spinal cord and canal, MRI is the imaging procedure of choice (Fig. 42.8). Extra-CNS indications include CHD, abnormalities of great blood vessels, masses involving mediastinum, chest wall and pleura, hilar and mediastinal adenopathy, liver masses, hemosiderosis, neuroblastoma, pelvic tumors, tumors of soft tissues and bones, abnormalities of joints, growth plate injuries, slipped capital femoral epiphysis, aseptic necrosis and vascular anomalies.

Currently, 3/4th of MRI in pediatric practice is accounted by CNS.

Nuclear Medicine (Radionuclide Scintigraphy)

Whereas ultrasonography, CT scan and MRI give principally anatomic information, nuclear medicine procedures are used to obtain functional information about various organ systems. Special imaging devices

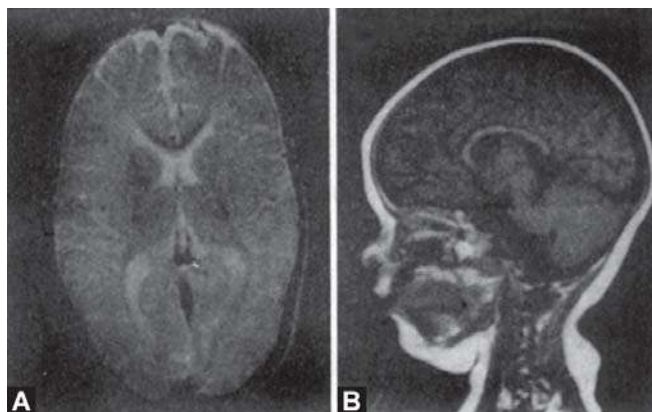

Fig. 42.8: MRI of an 18-month-old. Picture on left shows a mild cerebral atrophy with little dilatation of the interhemisphere fissure, reduction of cerebral mass in frontotemporal region and in fissura Sylvii area. Picture on right shows hypodensity of centrum semi-ovale and rarefaction of the internal capsule (T2-weighted image)

like gamma cameras and computer system give static or dynamic images.

Sedation and immobilization are essential prerequisites for nuclear medicine procedures.

Different compounds labelled with the isotope, ^{99m}Tc , are utilized to evaluate various organ systems. For instance, the radionuclide used for GIT is ^{99m}Tc -sulfur colloid or phytate (oral), for musculoskeletal system, it is ^{99m}Tc -MDP, for CVS, it is ^{99m}Tc -labelled RBC, for GUS, it is ^{99m}Tc -DTPA, and for oncology, it is ^{131}I -MIBG, ^{99m}Tc -MDP or ^{201}Tl thallium chloride.

Nuclear medicine procedures are safe, reproducible and cost-effective.

COMPUTERS: APPLICATIONS IN PEDIATRICS

- A. *Hospital information system:* Communication (store and display), and advice (decision and monitoring guidelines).
- B. *Patient database management:* Clinical data management.
- C. *Clinical laboratory:* Autoanalyzer leukocyte automatic recognition computer (LARC), chromosomal analysis, ECG, EEG, EMG.
- D. *Decision making:* Algorithmic methods.
- E. *Medical imaging:* CT Scan, PET, SPECT, MRI, US, NM imaging.
- F. *Critically ill:* Closed loop ICU

- G. *Therapeutics*: Digital therapy
- H. *Handicapped*: Devices for deaf and dumb.
- I. *Research*: Model building and simulation.
- J. *Literature search*: Medical database-MEDLINE
- K. *Testing and instructions*: Simulation of clinical encounters, drill and practice.
- L. *Pediatric education*: Interactive learning.

HEAT INJURY

Exposure to excessive heat, raising the body temperature beyond the acceptable limits, may adversely affect the child in a number of ways.

Heat syncope refers to a situation in which a child standing in the sun for prolonged periods becomes pale with fall in blood pressure and sudden collapse/fainting. It results from lack of blood supply to brain because of reduced return of blood to the heart as a consequence of vasodilatation and pooling of blood in the lower extremities. Interestingly, body temperature may not be raised. Response to shifting the child to a shady neighborhood and making him lie comfortably with his head slightly tilted down is gratifying. As a rule, he recovers in a matter of 5 to 10 minutes.

Heat cramps manifested by painful and spasmodic contractions exercise in hot and humid environment due to excessive loss of sodium and chlorides from body.

Heat hyperpyrexia, manifesting with body temperature of 106°F, is usually the result of disturbed heat-regulating centre/mechanism.

Heat stroke, manifesting with as high a body temperature as 110°F, dry and hot skin delirium, seizures and significant change in sensorium, results from failure of temperature regulating mechanism leading to hyperpotassemia which may even prove fatal.

Treatment consists in lowering the body temperature by ice-water baths until it falls to 102°F.

For heat injury in case of newborn, see Chapter 17.

SHOCK

The term, shock, denotes a clinical state of poor perfusion to the extent that the body demands are not suitably met from a great increase in metabolic demands (oxygen consumption) and/or decrease in metabolic supply (oxygen delivery).

Types

Two major types are recognized: intravascular hypovolemia and intravascular normo- or hypervolemia.

Intravascular hypovolemia is caused by loss of volume in the form of loss of blood (severe hemorrhage), protein-rich fluid (nephrotic syndrome, burns), or protein-poor fluid (acute gastroenteritis), or decrease in vascular resistance (anaphylactic shock, drugs, denervation injuries and early “warm” septic shock).

Intravascular normo- or hypervolemia is caused by cardiac dysfunction (coronary artery disease, myocarditis, cardiomyopathy, hypoxemia, metabolic insult), inflow obstruction (pericardial tamponade, intracardiac tumors), outflow obstruction (malignant hypertension, congenital heart disease in the form of severe aortic stenosis or coarctation, or hypoplastic left heart syndrome), and arrhythmias (supraventricular tachycardia).

Clinical Manifestations

These are by and large similar in the two types and include tachycardia, normal or low blood pressure, cool peripheral extremities due to profound vasoconstriction and hypoperfusion with the increasing severity of volume loss, there is tendency for the cooling to extent to the proximal parts. In shock due to loss of resistance, patients extremities are unduly warm due to vasodilatation. In addition, postural hypotension may be remarkable. An important example of this type of shock is septic shock associated with septicemia. As the vascular epithelium in this shock loses its integrity, it starts leaking fluid into the perivascular space, patient may develop adult respiratory distress syndrome (ARDS). With further progression, myocardial function decreases with reduced cardiac output together with secondary severe vasoconstriction. This is the stage of cold shock.

Diagnosis

It is based on a good history, physical examination and laboratory support.

As the laboratory results are likely to take time, resuscitation of the patient with cardiorespiratory collapse and rest of the initial treatment must never

be delayed, especially his oxygenation, ventilation and access to the vascular system through IV line or intraosseous line.

Among laboratory tests of special importance are or packed cell volume (PCV), serum calcium, glucose, potassium, urea-nitrogen, creatinine, LFT, coagulation screen, blood culture, etc. Capillary refill time is a useful parameter of peripheral perfusion.

Swan-Ganz catheterization of pulmonary artery is of value to demonstrate a reduced cardiac output/index central venous pressure (CVP) and left atrial pressure (LAP), and very high systemic vascular resistance (SVR).

Cardiac evaluation in nonvolemic shock should further include an ECG, a chest X-ray and echocardiography.

Treatment

Treatment of hypovolemic shock due to loss of intravascular of volume is replacement of volume which is initially carried out by using isotonic solutions such as normal saline or lactated Ringer's solution. Whole blood, fresh frozen plasma or 5% albumin is administered in specific etiologic situations.

Treatment of hypovolemic shock due to decrease in vascular resistance is volume resuscitation and administration of a vasoconstrictor.

Treatment of septic shock depends on it stage. In the initial "warm" stage, volume resuscitation and vaso-constrictors are needed. In the subsequent "cold" stage, therapy should include positive inotropes and afterload reduction. Broad-spectrum antibiotics are strongly recommended. Steroids are indicated only when Waterhouse-Friderichsen syndrome is suspected.

Treatment of normovolemic/hypovolemic shock due to myocardial failure is volume resuscitation, antiarrhythmic, inotropic and afterload-reducing agents, and correction of hypoxemia and metabolic abnormalities.

EMERGING AND RE-EMERGING INFECTIONS

Definitions

The term, *emerging infections*, denotes newly identified and previously unknown infections that cause public health problems either locally or globally.

The term, *re-emerging infections*, refer to reappearance of infections that had practically disappeared or previously minor infections that have assumed a public health magnitude, or known infections whose multidrug-resistant strains (MDRS) have appeared causing problems in effective treatment.

Classification

Table 42.3 gives a classification of emerging and reemerging infections.

Table 42.3: Classification of emerging and re-emerging infections

- Newly-recognized infectious diseases with identified or unidentified causative pathogen: AIDS, nipah virus disease
- Previously-recognized infectious disease with a newly identified causative pathogen: Whipple disease (microorganism *Trophe-rema whippleii*)
- Previously known disease now identified as being of infectious origin: Peptic ulcer disease (microorganism *H. pylori*)
- Known infectious diseases that are developing resistant strains: Multidrug-resistant strains (MDRS of typhoid fever, tuberculosis, Staphylococcus, *Streptococcus pneumoniae*).

Noteworthy Emerging and Re-emerging Infections

Table 42.4 gives the list of emerging and re-emerging infections important in pediatric practice.

Contributing Factors

These are summarized in Table 42.5.

Control Measures

These include surveillance on outbreaks globally, newer vaccines as also vaccines with easier mode of administration, applied research, public health measures aimed at awareness and prevention, judicious use of antibiotics and MDR-resistant drugs.

EVIDENCE BASED MEDICINE (EBM)

EBM may be defined as "the process of systematically finding, apprising and using contemporaneous research findings as the basis for clinical decisions".

Table 42.4: Important emerging and re-emerging infections

Emerging Infections
HIV
SARS*
Bird flu**
<i>H. pylori</i>
<i>Chlamydia pneumoniae</i>
<i>Ehrlichia chaffeensis</i>
<i>Legionella pneumophili</i>
<i>Bartonella burgdoferi</i>
MDRS <i>M. tuberculosis</i>
MDRS <i>S. typhi</i>
MDRS <i>Staphylococcus aureus</i>
<i>Enterococcus</i> species
<i>E.coli</i> 0157.H7
<i>Vibrio cholerae</i> 0139
Hepatitis C
Hepatitis E
Re-emerging infections
<i>Leishmania donovani</i>
Malaria
Leptospirosis
Plague
Filariasis
Dengue
Japanese B encephalitis

* Severe acute respiratory syndrome

** Avian influenza

Table 42.5: Factors contributing to emerging and re-emerging infections

- Advanced diagnostic modalities
- Behavioral and cultural changes
- Population growth shifts
- Sanitation
- Environmental changes
- Genetic changes
- Antibiotic resistance
- Immunosuppression
- Globalization
- Enhanced childcare facilities

In other words, it is the judicious use of current best evidence in making decisions about the care of individual patients. Thus, the systematically developed statements help in patient care in specific clinical circumstances. It is believed that such an approach makes clinical decision-making easy and improve quality of health care.

Need for the EBM

Certain changes in the health care scenario have brought about an increased accountability on the part of doctors.

- The increased access to medical information has increased patient awareness.
- The consumer protection act and similar movements in other countries where non-medical persons can question the medical management has led to stress on accountability on part of clinicians.

Essential Steps in EBM

- Identifying a clinical problem that needs a solution.
- Finding the evidence.
- Apprising the evidence for its credibility.
- Applying it in clinical situations.

Sources of EBM

These include

- Systemic reviews such as Cochrane Database of Systematic Reviews
- Journals and software such as Journal of Evidence-based Health
- Websites such as Evidence-based Pediatrics University of Michigan (<http://www.med.umich.edu/pediatrics/ebm>)
- Organizations such as Cochrane Collaboration School of Health and Related Research (SchHARR).

Cochrane collaboration is the largest collection of evidence-based resources. It is named after Dr AL Cochrane who founded it in 1993, thereby pioneering the use of EBM. Its components are

- Cochrane Database of Systematic Reviews
- Database of Abstracts of Reviews of Effectiveness (DARE)
- Cochrane Controlled Trials Register
- Cochrane Review Methodology Database
- Reviewers Handbook on the Science of Reviewing Research
- A Glossary of Methodological Terms and Cochrane journal.

Limitations of EBM

- EBM practice needs new skills which are difficult to be developed by a busy practitioner

- It boosts the cost of health care
- Rather than taking advantage of clinician's experience and judgement, it promotes the so-called "cookbook medicine"
- Whether it has indeed helped in clinical circumstances remains unclear
- It fails to provide answers to all clinical controversies since evidence is based on primarily randomized controlled trials and systematic reviews.

FURTHER READING

Articles/Chapters

1. Banerjee SR, Banerjee S. Adoption. In Banerjee SR (Ed): *Community and Social Pediatrics*. New Delhi: Jaypee 1995;313-324.
2. Dikshit AK. Nutritional dystrophy and anemia. *Indian J Child Health* 1957;6:132.
3. Gupte S. Infantile tremor syndrome: a growing Asian problem, *5th Intern Child Neurology Congr*, Tokyo 1990.
7. Gupte S. Infantile tremor syndrome Revisited. In *Recent Advances in Pediatrics (Special Vol 18: Pediatric Neurology)*. New Delhi: Jaypee 2007.
6. Jenson HB. Chronic fatigue syndrome. In Jenson HB, Stanton BF, Kliegman RM, Behrman RE (Eds): *Nelson Textbook of Pediatrics* (18th edn). Philadelphia: Saunders 2008;863-866.
9. Sharda B. Infantile tremor syndrome. In Gupte S (Ed): *Recent Advances in Pediatrics - 3*. New Delhi: Jaypee 1993;55.

Book/Monograph

1. Henry EW. *Chronic fatigue Syndrome*. Boston: Academic 2006.

PART SEVEN

Pediatric Procedures

Pediatric Practical Procedures

Vasudev Vatwani, Suraj Gupte

INTRODUCTION

Each and every pediatric scholar must learn the technique and develop skill in actually carrying out the frequently employed practical procedures, some therapeutic and others diagnostic, in pediatric practice. Most of these procedures can be performed bedside in addition to the procedure room.

GENERAL RULES/PRECAUTIONS

These are summarized in Box 43.1.

Box 43.1: Vital general rules in pediatric practical procedures

- Before actually carrying out a procedure, salient features of the procedure should be explained to the attendants and to the grown-up child to ensure their cooperation. For all major procedures such as lumbar puncture, liver biopsy or bone marrow aspiration, it is obligatory to obtain a written and signed consent from the parents.
- All necessary equipments, including local anesthesia, requisite needles, containers, test tubes, syringes, etc. should be readily available near the procedure table to avoid last minute confusion and panick.
- The chamber in which the procedure is carried out should be well lit, tidy, noise-free and neither too cold nor too hot.
- The procedure should be performed under aseptic condition, including scrubbing and handwashing.
- A reasonable number of observers/assistants should be around to keep a check on the cardiorespiratory status as also for help in the procedure.
- Adequate positioning and restraint of the child during the procedure are vital for the successful outcome of the procedure.

RESTRAINT AND POSITIONING

In order that a technical procedure is carried out successfully, particularly in infants, it is necessary to have the patient properly restrained and positioned. A struggling child will only lead to failure and disappointment.

Some centers may have the so-called “infant immobilization boards” which are quite useful. A commonly employed and a simple method of restraint, however, consists in mummifying the infant in a rectangular sheet. The infant is placed in the center of the sheet that is spread on a table. Only infant’s head and neck should remain projecting beyond the upper border of the sheet. The infant’s right arm is then straightened and adducted by the side of his trunk. The short edge of the sheet is passed in front of the arm, through the axilla and then behind the trunk. This end is then pulled and taken close to the short border of the sheet on infant’s left side. The same procedure is repeated for the left arm. The edges should be secured firmly with adhesive tape or safety-pins. An additional sheet may be wrapped around infant’s legs to achieve still better restraint.

Remember to examine the digits for color, temperature and capillary pressure (indicating proper circulation) after restraining a limb. Also, make sure that cardiorespiratory function is not impaired.

INTRAMUSCULAR INJECTION

Usual Sites

- In infants and young children, anterolateral aspect of mid thigh

- In older children, in whom gluteal muscles are well developed, upper and outer quadrant of buttocks (gluteal region).
- In children and adolescents, mid-deltoid areas

Method

- Hold the child securely to prevent movement of extremity.
- Thoroughly clean the skin with an antiseptic sponge, moving circularly from center outwardly.
- Hold skin taut and then insert the needle quickly.
- Check that needle is not in a blood vessel by a slight aspiration.
- Inject the material completely and then withdraw.

Special Note

- Size of needle varies (22-24 gauge size) with the viscosity of the drug being injected and the age of the child. It should not be more than 2.5 cm in length.
- In case of anterolateral aspect of thigh, needle should be inserted at an angle of 45 degree, pointing toward the knee.
- In case of gluteal region, the child should lie in prone position in the bed and the needle inserted perpendicular to the surface on which child is lying and not to his skin.
- Immediate massage and subsequent use of the muscle aids in absorption of the drug.

SUBCUTANEOUS INJECTION

This is a common mode of administering such vaccines as measles and MMR and a few drugs. It is preferable to use the outer aspect of child's upper arm.

Method

- Clean the area using appropriate agent (variable for different vaccines).
- Pinch up the skin with your fingers.
- Push a subcutaneous needle into the skin at an angle of about 60 degrees.
- Draw on the plunger to check if the needle is not in a blood vessel.
- Administer the drug.

Special Note

Do not rub vigorously over the injection site.

INTRADERMAL INJECTION

This route is most often used for administering BCG vaccine and tuberculin (Mantoux) test.

Method

- Clean the area of skin appropriately.
- Support child's arm with your nondominant hand and use finger to stretch the skin.
- Holding the syringe in your dominant hand almost flat on patient's skin, insert the needle into the skin with bevel of needle facing up, taking care that only the needle tip enters skin.
- Hold your nondominant thumb to hold the syringe close to skin while you inject the material.

Special Note

- Don't rub the site.
- After the injection, a clear flat raised wheal at the site should develop.

VENIPUNCTURE

For venipuncture, the choice is a visible vein in the antecubital fossa, back of the hand, dorsum of the foot or scalp. If not easily available, one may puncture the femoral, external jugular or internal jugular vein.

Femoral vein puncture consists in holding the hip fully abducted and the knee flexed to 90 degrees and then palpating the femoral artery below the inguinal ligament (Fig. 43.1). The femoral vein is then entered by introducing the needle, perpendicular to the skin, just medially to the artery. The needle is allowed to pin the vein against the femur. After the needle has

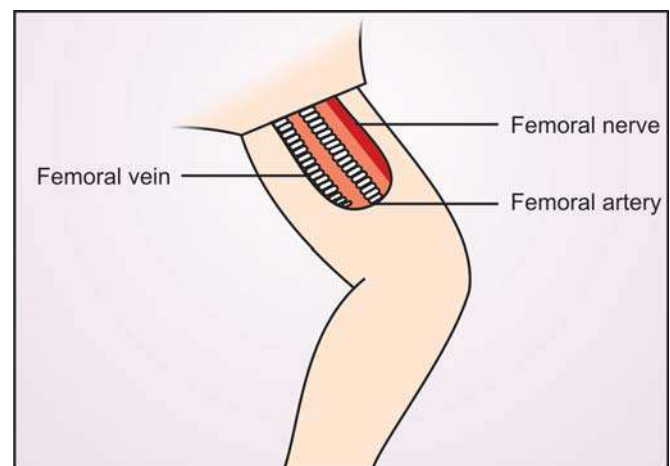

Fig. 43.1: Femoral vein puncture. Note that the vein lies medial to the artery

touched the bone, it is slowly withdrawn using negative pressure on the syringe. While this is being done, blood starts gushing into the syringe when the needle enters the lumen of the vein. After obtaining the blood, the needle is gently removed. Thereafter, firm and steady pressure should be applied over the vein for at least 2 minutes and preferably for 3 to 5 minutes.

Femoral puncture is a risky procedure. Accidental puncture of the artery may cause hematoma, transient cyanosis or even ischemia and gangrene of the foot if the artery goes into prolonged spasm. Osteitis of the femur and arthritis of the hip may occur in occasional instances.

External jugular vein puncture consists in placing the child on a table so that his shoulders are touching the table and the head is lying at a lower level than that of the trunk. The head is then turned through 90 degree to one side so that the external jugular vein is stretched and becomes visible crossing the sternomastoid muscle. It is at this point that the vein is punctured, especially when it gets distended while the child is crying. It is wise to exert pressure over the puncture side for 3 to 5 minutes after the needle has been withdrawn.

Internal jugular vein puncture is done by inserting the needle half way down the posterior border of the sternomastoid. The needle is directed beneath the muscle towards the suprasternal notch. The blood flows freely as the vein is entered, provided that a gentle but constant suction is maintained through the procedure. Sometimes, blood may be obtained only when the needle is being withdrawn. After removing the needle, firm pressure should be exerted over the puncture site for 3 to 5 minutes so as to reduce pressure in the vein. The child should be in his sitting position while this is done.

The complications of the procedure include hematoma, and damage to lungs (especially upper pleural space) and the trachea.

Collection of repeated blood samples, as in glucose tolerance test, may be done from a single venipuncture. A scalp vein needle is inserted in an antecubital or hand vein. A 2 to 3-way stopcock is inserted into the catheter end. The dead space of the scalp vein catheter is filled with heparinized saline. When blood sample is required, the stop-cock is removed and the solution filling the catheter is withdrawn and discarded. A second syringe is then employed to obtain the desired

quantity of blood. The catheter is again filled with heparinized saline solution and closed with stopcock until next sample is required. Remember that the samples obtained in this way are somewhat heparinized and are a source of plasma and not serum.

INTRAVENOUS INFUSION

In older children, an antecubital or wrist vein is usually good enough for intravenous infusion.

Upto the age of 4 or 5 years, scalp vein infusion serves well. In a newborn, umbilical vein may be handy for exchange transfusion. As and when peripheral veins are not available in an emergency situation such as shock leading to collapsed peripheral veins, it may become necessary to use saphenous or femoral vein as such or by venesection (cutdown or cutopen). Figure 43.2 highlights various sites for IV infusion.

Scalp Vein Infusion

Advantages of scalp vein infusion include rapidity of insertion, minimal trauma, steadiness and stability, and preservation of veins for future needs. Its difficulty lies in as much as that it is essential to have the said area of scalp shaved which is often resented by the parents in India.

The veins most frequently employed are branches of temporal vein, posterior auricular vein and those on the forehead. When a suitable vein is detected, the hair over the area should be shaved. The skin is sterilized with iodine and spirit or ethanol. The vein is then distended by such stimuli as tapping it sharply

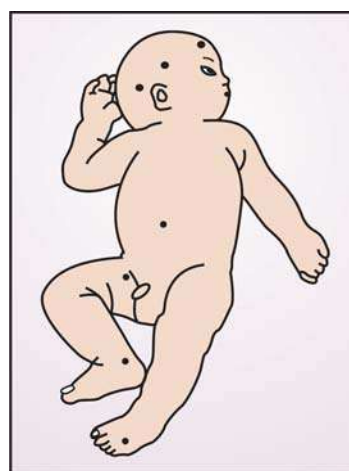

Fig. 43.2: Sites for intravenous infusion

with a finger and by obstructing the venous return by pressing a finger against a proximal segment (Fig. 43.3). Once the vein is fixed by stretching the skin taut with fingers, the needle is made to pierce the skin beside the vein and inserted beneath the skin for a short distance before actually puncturing the vein. As the needle enters the vein, blood begins to flow into the polythene tubing. If the vein is collapsed, blood may not come in the tubing. A small quantity of saline is injected from the syringe into the tubing. If the needle is not in the vein, there appears a subcutaneous swelling. Once the needle is *in situ* (it is good to push it as far as possible into the vein), it should be fixed at an angle of 30 degrees to the scalp with strips of adhesive plaster (Fig. 43.4). It is useful to tape a loop of the tubing also to the adjacent scalp.

Now is the time to connect the scalp vein needle to the drip set. In small infants, the gravity method of administering fluids from a bottle suspended at an elevation may fail because of the very small veins. In such instances, fluids may be administered slowly by a syringe.

Venesection (Cutdown or Cutopen)

In a seriously sick child, if fluids are urgently to be administered intravenously but no peripheral vein is available for venipuncture, cutdown may become necessary.

The recommended site is anterior to the medial malleolus where the internal saphenous vein runs. However, the same vein can be used at any site along its route.

The whole procedure should be done with full aseptic technique as in any surgery. After the leg is bound to padded splint in a position of external rotation, 1% procaine or xylocaine is infiltrated into the overlying skin of the prepared area. With a scalpel, a full thickness skin incision, 1 cm long, is made right angle to the vein. The incision is spread wide enough to expose the vein which is dissected free of fascia and subcutaneous fat. A careful observation about the flow of blood would confirm that it is a vein and not a tendon or nerve. A ligature is then tied distally round the vein to occlude venous return. Through a small incision on the upper surface of the vein, a polythene catheter is inserted for a distance of 2 cm up the vein. As the blood begins to flow, a second ligature just above the site of insertion is tied firmly round the vein

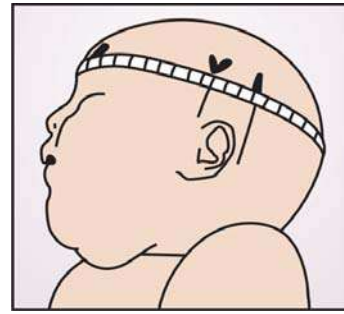

Fig. 43.3: Scalp vein infusion. Note the elastic band round the head. It acts as a tourniquet. The thumb may also be used to occlude the vein



Fig. 43.4: Scalp vein infusion. Note that the needle is *in situ*. It should be fixed with adhesive at an angle of 30 degrees to the scalp

and catheter to secure the latter in place. The catheter is then connected to the intravenous drip set gently, avoiding pulling and tearing the vein or withdrawal of the catheter from it.

The wound is then closed with fine stitches (just two are fair enough), which are removed in 3 to 4 days, and covered with gauze and roller bandage. It is unwise to restrain the foot. That only boosts the risk of pressure sores and interference with circulation. Figure 43.5 shows the steps of venesection.

Umbilical Vein Catheterization

Umbilical vein may come in handy for exchange transfusion during the first week of life or for intravenous infusion, during this period of life, when other veins may not be available.

The procedure consists in sterilization of the cord area and then cutting the cord 2 cm from the skin junction, i.e. close to the base of the stump. With the

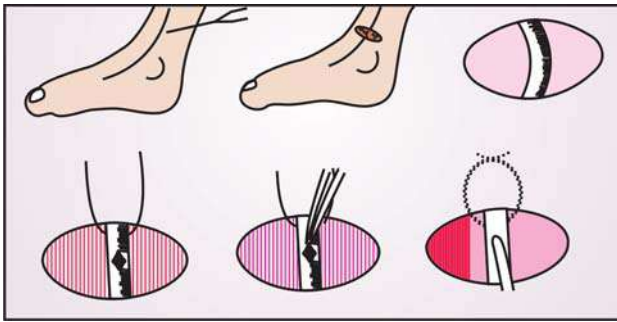

Fig. 43.5: Venesection. Note the steps

edge gripped with mosquito forceps, three blood vessels are seen at the base. Two are umbilical arteries with regular outline and thick wall. The umbilical vein has irregular outline and thin collapsed wall. After clearing the vein of any clot, etc. the catheter is advanced gently into its lumen for 5 to 7 cm. As soon as blood begins to flow freely into the catheter and then fills it completely, the catheter should be connected to the drip set or the syringe.

At the end of the procedure, a sterile polyvinyl marker is required to be inserted in the orifice of the umbilical vein. It should be tied into facilitate a subsequent catheterization. Also, it is a wise policy to send the tip of the catheter for culture. It may be a potential source for septic embolization.

ARTERIAL PUNCTURE

It is particularly indicated for blood gas analysis and invasive blood pressure monitoring.

The recommended sites are radial artery, branchial artery and temporal artery. The radial artery can be palpated in the center of the lateral third of the anterior aspect of wrist. Precisely speaking, it lies immediately lateral to the tendon of the muscle flexor carpi radialis. Branchial artery is the continuation of the axillary artery on the medial aspect of the arm and can be palpated with some difficulty. Temporal artery lies just anterior to the tragus of the ear. It is both palpable and visible once hair over the temporal region is shaved.

For the arterial puncture, the selected site is prepared aseptically, employing spirit, iodine and spirit in that order. A heparinized syringe with 21-23 gauge needle is employed for the puncture. In case of a radial puncture, the wrist is kept extended and the radial artery palpated and left hand fingers kept on it. Then, with the bevel facing upward, the needle is

inserted little superior to the proximal skin crease inclined at an angle of 45° to the artery. At this stage, the needle should be gradually withdrawn as gentle suction is maintained. If blood fails to flow into the syringe, another attempt should be made by pushing the needle again in either direction without withdrawing it from the skin.

Once the sample of blood has been collected, the puncture site should be kept pressed for 5 minutes or more to safeguard against bleeding.

The syringe (heparinized) containing blood sample is sealed and preserved in ice. It must be carried to the laboratory for immediate blood gas analysis.

Since an arterial puncture is often painful and may cause hyperventilation, it may well be in order to employ a local anesthesia.

In case multiple samples of arterial blood are needed over a relatively shorter time, it is advisable to place an indwelling arterial line. Such a line would require to be continuously heparinized (1 unit/ml saline; 3 to 5 ml/hour) to safeguard against thrombosis.

An alternative to arterial blood is arterialized capillary blood which may be obtained from a puncture over finger, heel or earlobe, provided that patient's tissue perfusion is good.

INTRASOSEOUS INFUSION

In emergency situations when intravenous approach cannot be established, intraosseous infusion may be ideal as a "tideover" temporary measure. Fracture, osteo-genesis imperfecta, osteoporosis, cellulitis, infected burns, etc. are its contraindications.

The flat anteromedial surface of proximal tibia, 1 to 2 cm below the tubercle, is the best site. Alternatively, distal tibia and distal femur may be employed (Fig. 43.6).

The prepared part of the restrained leg is first injected with local anesthesia. Then, a standard bone marrow needle or 14 to 18 gauge spinal needle is inserted perpendicularly to the skin. As soon as it reaches the periosteum, it is directed at a 60 degree angle inferiorly. Make sure that the bevel points away from the epiphyseal plate and the joint space. It is advanced further, using fair pressure. Arrival at the marrow is indicated by a loss of resistance. Usually, an insertion of the depth of 1 cm of the needle is sufficient for this purpose.

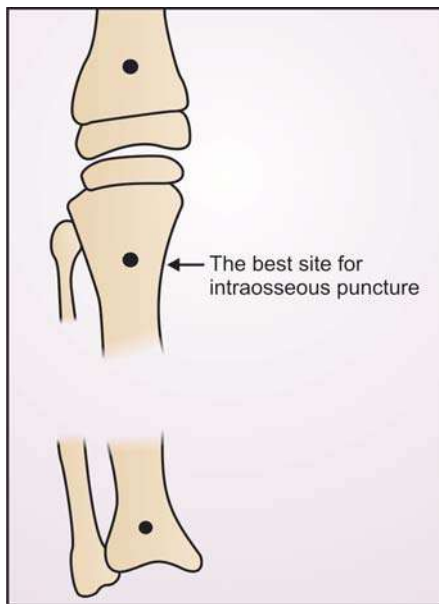

Fig. 43.6: *Intraosseous infusion.* Note the three sites recommended for insertion of the needle. Upper tibia is by and large the best site

Once the needle is in the marrow, blood or marrow content can be freely aspirated by a saline-filled syringe. If a block of the needle with marrow contents is suspected, a couple of ml of saline may be infused slowly to remove the block.

Once free flow of blood is ensured, the needle is connected to a standard intravenous drip. As in an intravenous drip, intraosseous infusion is run by gravity with the fluid bottle suspended 4 to 6 feet above the level of the patient.

The procedure is fairly safe. Nevertheless, occasional complications include extravasation of fluid into subcutaneous tissues causing skin necrosis, local infection, cellulitis, osteomyelitis, epiphyseal insult causing tibial fracture and fat embolism. It must be reserved for emergency situations and as a short-term measure.

SUBCUTANEOUS INFUSION

The old regimen of subcutaneous infusion (hypodermoclysis) may be employed under very pressing circumstances when a vein cannot be entered and it is not possible to do a cutdown either. A drawback of this method is that it may cause remarkable shift in the body fluids. Also, it is difficult to give large amount of fluid by this route.

The sites of choice are the subcutaneous tissues of axilla, upper back (interscapular area), thigh and flank.

A sterile fluid is run under the skin with a syringe or through a drip-set, using 20 gauge needle, until a tense swelling is produced and it is difficult to inject any more. Then an ampoule of hyaluronidase is injected straight into the needle or into the plastic tubing. This together with gentle massage diffuses the fluid into the tissues. By this technique 30 to 40 ml fluid/kg body weight can be injected at one sitting.

Remember to avoid giving glucose saline over a long period by this method. It is advisable to restrict the method for only isotonic solutions.

INTRAPERITONEAL INFUSION

Though not a preferred method, blood and isotonic fluids may be administered by intraperitoneal route.

A short bevelled needle is introduced through sterilized skin at the junction of upper one-third and lower two-third between the umbilicus and pubic symphysis. The drip set is connected to the needle. If the infusion starts running rapidly, the needle is in the peritoneal cavity.

By this method, about 30 ml/kg body weight of fluid can be administered. An important precaution is that the bladder must be voided while performing this procedure.

RECTAL INFUSION

If a soft catheter is introduced into the rectum and then connected to drip-set, saline may be administered slowly at a rate of 30 ml/hour. The method is simple and can be carried out by nursing staff. It is, however, no match for the intravenous infusion as far as the reliability of the infusion in the presence of dehydration is concerned.

BONE MARROW ASPIRATION

For marrow puncture, the usual site and the method of choice for children is the iliac crest. In children less than 2 years of age, more so in the first 3 months of life, a point on the anteromedial aspect of tibia, about 2.5 cm below the tibial tubercle, is the recommended site. Sternal puncture is hardly required in children.

The procedure is carried out with full surgical precautions in a well-sedated child. The skin is infiltrated with 1% procaine or xylocaine up to the

periosteum. With a rotating action, the marrow trocar and cannula are inserted through the skin down to the periosteum and then through the cortex into the marrow cavity. As soon as the needle enters the cavity, some “give” is felt and there is sudden lack of resistance. With the needle firmly fixed *in situ*, trocar is removed. A fleck of marrow on the tip of the trocar confirms that the needle is in the marrow cavity.

The time is now ripe for fitting a dry 20 ml syringe to the needle. With strong suction for a few seconds, about 0.2 ml of marrow is aspirated into the syringe. After the aspiration, trocar is replaced and the needle withdrawn. The puncture site is pressed with a finger for 3 to 5 minutes. A sterile dry dressing is applied over the site.

The aspirate is smeared in equal amounts on 8 to 10 clean glass slides which are waved in the air to accomplish fast drying.

BONE MARROW TREPINE

The child is placed in lumbar puncture position. At the lower end of the iliac crest, posterior superior iliac supine is located. The point for puncture is 1 cm above the spine in a young child and 2 cm above it in an older one (as is the case in marrow aspiration).

After local anesthesia, the skin is incised with a sharp scalpel. The stylet of the Tamshidi-Swain trephine needle is locked and the handle inserted through the incision so that it touches the iliac crest. With steady pressure, it is rotated clockwise and anticlockwise down into the bone. As it cuts into the bone, making the operator feel the “give”, the stylet is removed. The needle is then little withdrawn and pushed about 2.5 cm in a different direction. This breaks the bone specimen at the distal edge of the needle.

After gently removing the needle, the chip of bone is extruded from it into a suitable histologic fixative.

LUMBAR PUNCTURE (LP)

This procedure is best avoided in the presence of papilledema in which case herniation of the medullary cone may prove dangerous. In local diseases of the lumbar spine and skin sepsis also, it is advisable not to do it.

The child is restrained either in lateral recumbant position with the neck flexed to the chest and the knees

drawn to the abdomen, or in a sitting position. An imaginary line joining the two iliac crests passes through the 4th lumbar vertebra. A space above (3rd intervertebral space) or below (4th intervertebral space) this line may be chosen as the site of the lumbar puncture.

The chosen site is prepared aseptically and then preferably infiltrated with 1% procaine, even in neonates. The lumbar puncture needle with stylet in position is introduced into the said space, pointing somewhat towards the head. As the needle pierces the dura, a distinct “give” is felt. At this point, stylet may be withdrawn to watch for the fluid. The latter is collected in sterile vials. At the beginning and end of collection, the pressure may be measured employing a 3-way stopcock and manometer.

After this, the stylet is replaced and the needle is withdrawn. The puncture site is sealed with tincture benzoin.

The details of CSF examination are given in Chapter 44 (Pediatric Laboratory Procedures).

SUBDURAL PUNCTURE OR TAP

Though not as safe as lumbar puncture, it is indeed indicated when subdural effusion or hematoma is suspected.

The well-sedated child is restrained adequately, the head being held by the nurse. The shaved scalp in the region of the anterior fontanel is prepared aseptically. A fine bevelled needle with stylet is employed to puncture the lateral angle of the fontanel. It should enter at an angle of 90 degree to the scalp. The operator feels a “give” as the needle pierces the dura. At this point the stylet is withdrawn. The subdural fluid flows out as proteinaceous, cloudy, yellow, brown or red material. It is collected in sterile vials, remembering that not more than 10 to 15 ml of it is to be removed per side at one sitting.

After the needle is withdrawn, firm pressure is exerted with a cotton wool ball. The puncture is sealed with tincture benzoin.

The procedure is always to be repeated on the opposite side, irrespective whether the first tap is negative or positive (Fig. 43.7).

The subdural fluid is subjected to usual laboratory investigations. Its protein content should be at least 40 mg% more than that of CSF obtained by lumbar puncture.

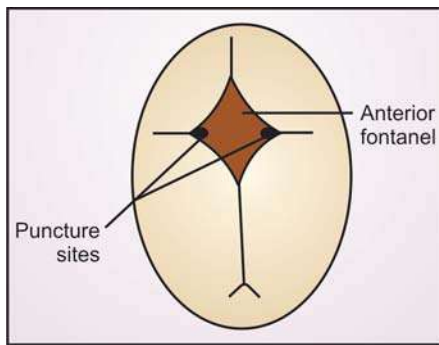

Fig. 43.7: *Subdural tap.* Note the two sites of puncture. The procedure must always be done on the other side but with a separate needle. No suction with the syringe must ever be applied

A frequent observation is that after the tap some leakage of the fluid occurs under the scalp, leading to false positive transillumination.

Its complications include hemorrhage, persisting effusion, and, infrequently, porencephaly, if the brain is punctured.

VENTRICULAR TAP

Its technique is more or less the same as that of subdural tap. Here the needle is, however, much longer (Fig. 43.8). Secondly, it is required to be advanced towards the inner canthus of the ipsilateral eye and not 90 degrees (perpendicular) to the skull.

THORACENTESIS

The procedure is employed to remove pleural fluid or air (both for diagnostic and therapeutic purposes), to induce pneumothorax, or to inject antibiotics in cases of empyema.

In order to know the exact position of effusion, an X-ray chest should always be done before undertaking thoracentesis.

The chosen area (8th, or 9th intercostal space in the posterior axillary line, or the area of maximum dullness) is prepared aseptically while the child sits back on the bed and leans forward against a stool, bed, stand or chair back. The area is infiltrated with 1% procaine down to the pleura.

A large-bore needle with a syringe is inserted in the space along the upper edge of the lower rib. This is important to avoid injury to the intercostal nerves and blood vessels. Entry into the pleural cavity is

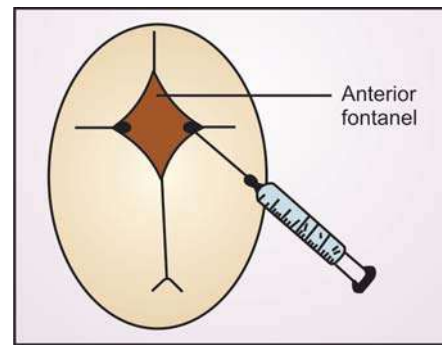

Fig. 43.8: *Ventricular tap.* A relatively longer needle must be advanced forwards and inwards towards the inner canthus on the same side. Suction with the syringe is contraindicated

indicated by a feeling of “give”. With suction, the fluid begins to flow into the syringe. Not more than 100 to 500 ml should be removed at a time. Since the risk of introducing air (pneumothorax) is considerable, it is advisable to employ a 3-way stopcock between the needle and the syringe.

When the needle is withdrawn, the skin puncture should be sealed with tincture benzoin.

PERICARDIAL PUNCTURE

The procedure is indicated in suspected pericardial effusion and for relieving cardiac embarrassment in cardiac tamponade due to collection of large amount of fluid or blood.

The child is made to sit at 60-degree angle. The chosen site (5th left intercostal space, 1 to 2 cm within the left outer border to the cardiac dullness, or just outside the apex) is prepared aseptically and then infiltrated with 1% procaine. A large-bore needle, connected to a 3-way stopcock and 50 ml syringe, is inserted into the intercostal space at the upper border of the rib. The direction of the needle should be posterior and towards the spine. As soon as the needle edge is in the pericardial space, fluid begins to come on aspiration.

ABDOMINAL PARACENTESIS

After voiding, the patient lies in semi-sitting position in the bed or on a table. The skin below the umbilicus is prepared aseptically and 1% procaine infiltrated at the site of puncture, usually midway between the umbilicus and pubic symphysis (in the lower quadrant

or in the midline). A large-bore needle or trocar is then pushed into the abdominal cavity. Its direction should be rather oblique so that leakage of fluid may be prevented.

After sufficient fluid is aspirated, the puncture site is sealed with tincture benzoin to prevent oozing.

SUPRAPUBIC BLADDER ASPIRATION

When collection of urine without contamination becomes difficult in infants and young children, this procedure comes in hand.

Method

- Make sure that bladder is full, i.e it should be palpably enlarged above pubis.
- Sterile the overlying skin carefully.
- Place the infant in a supine position on a flat surface with proper restraint in frog-leg position.
- Firmly and swiftly introduce a 21 or 22 gauge size needle attached to a syringe at a point 1-2 cm above pubis with needle, almost perpendicular to skin with a slight tilt (about 10 degree) downward.
- As the bladder is penetrated, change in resistance to the needle movement is felt.
- At this stage, aspirate the urine applying light pressure on the syringe.
- After urine has been collected, withdraw the needle with a single swift motion and apply pressure over the spot for some time.

HEEL PUNCTURE

It is useful for collecting capillary blood sample in neonates and young children for various hematologic, biochemical and blood gas analysis.

Method

- Heel is warmed by applying a warm towel to it for 5 minutes.
- Puncture the area (most medial or lateral aspect) with a needle perpendicular to the surface, the puncture not exceeding 2.5 mm depth.
- First drop of blood is wiped off and subsequent flow is collected in a capillary tube.

Special Note

Heel should never be milked to increase sample over flow.

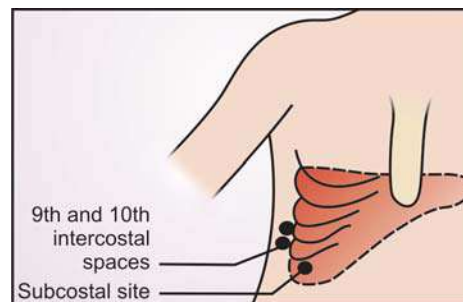

Fig. 23.9: Liver biopsy. Note the sites

LIVER BIOPSY

Liver biopsy may provide valuable information in primary diseases of the liver such as Indian childhood cirrhosis, other cirrhosis, hepatitis, unexplained hepatomegaly as well as diseases like tuberculosis in which liver involvement may be secondary.

Before doing a liver biopsy, it is important to ensure that the prothrombin time of the patient is within normal limits. The blood group should also be ascertained. In the presence of a bleeding diathesis, the procedure is best not done.

The well-sedated child is made to lie on the edge of the table with his hands kept behind the head. In the midaxillary line, at the level of the tenth intercostal space, local anesthesia is infiltrated after proper cleansing of the skin with iodine and spirit. The liver biopsy needle (Tru-cut needle or Vim-Silverman needle) with the stylet is inserted through the ninth or tenth space or through subcostal approach into the liver tissue (Fig. 43.9). Then the stylet is withdrawn and the split portion is pushed inside the hollow needle. It is advanced further into the liver. At this stage, the outer needle too is advanced into the liver fully. Thereafter, the whole needle is rotated through a full circle. This breaks the liver chip (that is attached to the needle) from the rest of the liver. The entire apparatus is withdrawn. The skin wound is sealed with tincture benzoin and the child watched for the next 24 hours.

Alternatively, one may use the Mengheni needle. The advantages of this needle include (i) no rotation of the needle is required, and (ii) the procedure takes less time (just half a minute).

KIDNEY BIOPSY

Kidney biopsy is of value in evaluation of cases of nephrotic syndrome not responsive to usual therapy

with corticosteroids, progressive renal failure of obscure cause, undiagnosed hematuria, and such conditions as systemic lupus erythematosus (SLE). For evaluation of response to therapy and prognosis of the disease, periodic biopsies are of greater value.

Every child fixed for kidney biopsy must have a plain X-ray abdomen, ultrasound, and an IVP for ascertaining the position and the size of the kidneys prior to the procedure. It is dangerous to conduct this procedure in the presence of a bleeding diathesis, polycystic disease, solitary kidney, severe systemic hypertension, hydronephrosis and tumors of kidney or adrenal.

Following an adequate sedation, the child is made to lie prone with head turned to a side, arms abducted and forearms by the side of the head. A pillow or a rolled-up towel is placed under his abdomen.

The usual site for biopsy is 2 cm below and medial to the tip of the 12th rib (lower border). After the aseptic preparation of the site, 1% procaine is infiltrated locally. Then a 20 gauge long needle (about 8 cm) is inserted gradually in a sagittal plane parallel to the spine until it hits the kidney. The later moves up and down with respiration, provided that it is in. The depth to which it has entered is marked and it is withdrawn. The track is anesthetized.

Then, Tru-cut or Vim-Silverman needle with stylet is introduced along the anesthetized tract, while the patients takes deep breath, till it pierces the kidney capsule. The position is confirmed by to-and-fro movement of the needle with respiration. The stylet is removed and the forked cutting needle is inserted to its full length. The patient is asked to hold breath and the outer needle is pushed deeper so that it covers fully the forked needle. The whole apparatus is now rotated a full circle (360 degrees), leading to cutting in of the biopsy material from the kidney. Finally, the apparatus is withdrawn and the puncture site sealed with tincture benzoin.

The child is kept in supine position and observed for 24 hours. He should be encouraged to take enough of fluids and normal diet after he is out of the sedation.

If carefully done by an expert, kidney biopsy is a fairly safe procedure. Microscopic hematuria is usually seen in a large majority of the cases. It is transient and disappears in 2 to 3 days. Massive hemorrhage, pain abdomen, hematoma, intrarenal arteriovenous fistula, etc. may occasionally complicate the procedure.

INTUBATION

For technique of passing the tube into the stomach and tube feeding, see Chapter 12 (Infant Feeding).

For the purpose of obtaining gastric aspirate (lavage) for AFB, the child needs to be fasted overnight. When he wakes up in the morning, a 10 ml syringe is employed to aspirate all the gastric contents. The lavage thus obtained is collected into a sterile bottle. Then, 10 ml of distilled water is instilled into the stomach which is washed by frequent movements of syringe piston. The washing is aspirated and shifted to the same bottle. The material is sent to the laboratory for AFB (both direct smear and culture).

ENDOTRACHEAL INTUBATION

Refer Chapters 17 and 38.

PHOTOTHERAPY

Refer Chapter 17.

EXCHANGE TRANSFUSION

Refer Chapter 17.

LYMPH NODE BIOPSY

After making the skin incision directly over the lymph node proposed to be biopsied in line with the natural skin creases, blunt dissection should be done all around and under the node so that it is completely free. Then, the capsule is held with a forceps, making sure that the node itself is in no way held and traumatized, and removed.

After the lymph node is removed, it is cut in half. The cut section is inspected. Then the pieces are placed in formalin and transported to the pathology laboratory.

FINE NEEDLE ASPIRATION

Being minimally invasive, requiring no sedation It is very useful for cytological and bacteriological examination of a mass or a lymph node. It aids in tissue diagnosis and in determining what the course of management should be.

Requirements

- 2.5-4 cm (20-25 gauge) needle (a small bore needle causes less shearing force on tissues but obtain a very small sample)

- 10-20 ml plastic disposable syringe.
- Clean glass slides
- 70-90% ethanol for routine wet fixation.
- Containers with specific culture media whenever required.

Method

- Sterilize the site.
- Local anesthesia, though usually not required, may be employed in anxious children.
- Immobilize the lump or the skin over the area to be biopsied between your thumb and finger with one hand.
- Hold the syringe in the other hand and insert needle into assigned area, perpendicular to skin surface and position the needle within target tissues.
- Pull the syringe plunger to apply negative pressure.
- As pressure is maintained, make several punctures through the lump.
- Release the negative pressure.
- While needle remains in target tissue, withdraw the needle.
- Detach the needle, clear some air, 2-3 ml into syringe.
- Reattach the needle and blow aspirate on to the slide.

Special Role

As the sample tissue is very small, it gets suck into syringe lumen and is hard to remove. So, you may need to repeat the procedure.

Deep biopsies can be obtained with the assistance of radiologic and imaging techniques such as ultrasonography.

Caution

The following factors may contribute to an unsatisfactory yield during fine needle aspiration cytology (FNAC):

- When the needle misses the lesion tangentially
- When the central area is cystic/necrotic/hemorrhagic and devoid of diagnostic material
- When there is a small malignant lesion close to a dominant benign mass
- When the target tissue is fibrosclerotic and poor in cells.

GASTRIC LAVAGE

It is a very useful procedure in accidental poisoning (except corrosives and hydrocarbons), in managing upper gastrointestinal bleeding and for collecting samples of gastric juice for diagnosis of acid-fast bacilli.

Method

- Have all the equipment ready (Ryle's tube, suction apparatus, liquid paraffinmouth gag and saline)
- Place the child supine with head hyperextended and supported underneath by a hand.
- Open the mouth and use the mouth gag.
- After lubricating the tube with liquid paraffin (avoid it in a neonate), advance the tube over the tongue towards the back of throat. Keep advancing the tube until the mark on the tube reaches the tip. Make sure tube has not entered trachea. Passage into trachea causes sudden apnea and obstruction to insertion of tube.
- Confirm that tube is in the stomach by pushing air through the tube and auscultating over stomach. Bubbling of air when the outer end is placed in a cup of water indicates that tube is in trachea rather than stomach.
- Fix the tube securely on the face with adhesive tape.
- Gently suction out the gastric contents. Perform lavage of stomach using aliquots of normal saline (10-100 ml/kg/cycle). Keep repeating the cycle till the color of the returning fluid is the same as the lavage fluid.
- While removing the tube, always pinch it end to prevent spilling of the contents into trachea.

Special Note

- The tube may well be inserted through the nostril.
- Don't use excessive force while passing the tube.
- Watch out for laryngospasm and bradycardia during the procedure.

MANUAL REMOVAL OF FOREIGN BODY FROM AIRWAY

Foreign body should be seriously suspected in case of spontaneous respiratory distress associated with coughing, gagging, stridor, cyanosis or wheezing. Don't try to remove it by finger sweep which may push it back and deep into the airway.

Removal in an Infant

Back Blow Chest Thrust

- Hold the infant face down on your forearm which in turn should rest on your thigh.
- Support head of your hand between the shoulder blades of the infant.
- Now turn the infant around as a unit to a supine position while firmly supporting the head and neck. Administer up to 5 quick chest thrusts in a similar method and location as used for chest compression.
- The whole process may be repeated until the foreign body is expelled out.

Removal in a Child Older than 1 Year

Subdiaphragmatic abdominal thrusts (Helmich's maneuver) increases the intrathoracic pressure and creates an artificial bout of cough which forces foreign body out of the airway. This maneuver is not employed in infants because of the risk of liver injury.

Helmich's Maneuver in Conscious Child

- Stand behind the child and encircle his torso by putting both arms directly under his axillae.
- Place the thumb side of one fist against the child's abdomen in midline, slightly above naval and well below xiphoid.
With the other hand, grasp the first and exert quick upward thrust taking care not to touch the xiphoid process or lower rib margin.
- Each thrust should be forceful enough and intended to relieve obstruction.

7 Helmich's Maneuver in Unconscious Child

- Position the child in a supine position and kneel at his feet.
- Place the heel of one hand on child's abdomen in the midline, slightly above the naval and well below the rib cage.
- Place the second hand on top of the first and press into the abdomen with quick upward thrust.

CARDIAC RESUSCITATION

As soon as cardiac arrest is suspected, the following steps should be taken:

1. At once clear the airway and administer mouth-to-mouth breathing for as long as necessary.

2. For closed cardiac massage, while the patient is supine on a firm surface such as a table or floor, place the heel of the hand over the lower part of the sternum. Press down firmly so as to depress the sternum by 1 to 5 cm. This needs to be repeated very fast, 90 to 120 times per minute. Palpability of a good femoral pulse is a reasonable sign of the adequacy of the force applied for the massage.
3. Check the size of the pupils from time to time. Good response to light is a sensitive indicator of the adequacy of the massage.
4. If, in spite of a good external cardiac massage, the patient fails to be resuscitated, obtain an ECG, and resort to such measures as improvement in oxygenation, replacement of blood volume deficit, intra-cardiac adrenaline, calcium or bicarbonate.
5. A fibrillating patient can often be made to have normal rhythm by employing an external defibrillator.
Finally, it may be clarified that the ultimate outcome of cardiac arrest depends on the etiologic factors(s). However, increasing number of infants and children can be successfully resuscitated if external cardiac massage is begun immediately on detection.

ASSISTED VENTILATION

The term, *assisted ventilation*, implies mechanical provision of oxygenation of circulation in order to maintain gaseous concentration and pH of blood at an optimal level in the event of respiratory failure (Table 43.1).

A *ventilator* is defined as a mechanical device for providing artificial ventilation of the lungs. It may be hand-operated or machinedriven. The machine-driven ventilator may be automatic and very sophisticated as regards its ability to control and monitor flow of air to the lungs. Ventilation may be of two types:

1. *Intermittent positive pressure* in which pulmonary ventilation is provided by administering oxygen for the inflation of lungs under positive pressure.
2. *Continuous positive pressure* in which pulmonary ventilation is provided by administering oxygen for inflation of the lungs under a continuous positive pressure that is never allowed to return to zero.

A. Bag and Mask Ventilation

This life-saving procedure usually employs self-inflating Ambu bag and is capable of delivering 90% oxygen if a corrugated tube is attached to the bag as a

Table 43.1: Etiology of respiratory failure needing ventilatory support

Systems	Neonates	Infants and children
Pulmonary	RDS, bronchopulmonary dysplasia, meconium aspiration, bronchopneumonia, PFC, pulmonary hemorrhage, congenital malformations	FB, epiglottitis, diphtheria, croup, angioneurotic edema, pneumonia, bronchiolitis, severe acute asthma, near-drowning, shock lung
Cardiovascular	CCF, cardiac arrest, shock, PDA	CCF, cardiac arrest, shock, post-cardiac surgery
Neurologic	HIE, severe apneic attacks, IVH, congenital polio, heavy maternal sedation, myopathy (WH disease)	Acute polio, GB syndrome, CNS infections, head injury, status epilepticus, ICSOL, uncal herniation.

reservoir. This kind of ventilation is most suitable for resuscitating an asphyxiated/apneic neonate (Chapter 17) in spite of reasonable suctioning, clearing of the airway plus tactile stimulation.

B. Continuous Positive Airway Pressure (CPAP)

CPAP consists in providing a continuous supply of humidified oxygen-air mixture. The patient exhales against a water column kept at a level to maintain the required pressure resistance in relation to the magnitude of the PEEP that is aimed at. It may be administered by a tight-fitting face mask, nasal prongs, nasopharyngeal catheter or endotracheal tube. CPAP is of particular benefit in RDS (HMD), inflammatory disorders, atelectasis, etc.

Mechanical Ventilation

When 100% oxygen or CPAP fails to revert apnea or acute respiratory failure, mechanical ventilation is indicated so that arterial pH and blood gases are maintained at the optimal level, i.e. within normal range. It is best suited in acute respiratory failure accompanying polio, Guillain-Barré syndrome, tetanus, accidental poisoning or other self-limited neurologic conditions.

Mechanical ventilation invariably needs intubation of the trachea. Some degree of hypercarbia and hypoxemia is quite acceptable if oxygen-induced or stretch-induced injury to lung is to be avoided. Moderate hypercarbia with PCO₂ 60 to 80 mmHg and moderate hypoxemia with oxygen saturation 85 to 95% are well tolerated.

Mechanical ventilation is, as a rule, started with conventional volume driven ventilators. If conventional ventilators fail to bring about improvement in oxygenation, high frequency jet or oscillator ventilators are used as rescue therapy.

Monitoring of ventilation by clinical and investigative measures is vital. In adequate ventilation, the subject shows pink color, adequate air entry and chest expansion with absence of retraction, prompt

capillary filling in just 2 seconds or less and normal BP. Pulse oximetry indicates oxygen saturation of 90 to 95%. Blood gas analyses shows paO₂ 60 to 90 mm Hg, paCO₂ 40 to 45 mm Hg and even up to 60 mm Hg in chronic situation, and pH 7.35 to 7.45.

During ventilation, a supportive care of high magnitude is warranted to ensure fluid and electrolyte homeostasis, thermoneutral environment and optimal functioning of CVS. Fluids are, as a rule, restricted since there is little insensible loss and high incidence of inappropriate secretion of ADH.

Weaning from the ventilator is guided by the clinical status, natural history of the underlying condition and status of blood gases, and is carried out in a set manner, stepping down the settings of the ventilator by increments. Before extubation, he is attached to CPAP mode and placed in oxygen hood.

Complications of ventilation are related to intubation, or barotrauma (Table 43.2).

Refractory life-threatening respiratory failure (not responsive to mechanical ventilation) is an indication for extracorporeal membrane oxygenation (ECMO).

Table 43.2: Complications of mechanical ventilation

<i>From endotracheal intubation</i>
Atelectasis, perforation of trachea/esophagus, avulsion of vocal cords, subglottic stenosis, superimposed infection
<i>From barotrauma</i>
Interstitial emphysema, pneumothorax, mediastinum, pericardium, peritoneum; subcutaneous emphysema

FURTHER READING

Article/Chapter

1. Singhi SC. *Intraosseous infusion Indian Pediatr* 1992;29:253.

Books/Monographs

1. Graeffe R. *Practical Pediatric Procedures*. New York: Hobel 1997
2. Henretig FM, King C. *Practical Emergency Procedures*. Hong Kong: Williams and Wilkins 1997.

Pediatric Laboratory Procedures

Suraj Gupte, Bhavna B Chowdhary

BLOOD EXAMINATION

Collection

For investigations needing small amount of blood such as hemoglobin estimation, peripheral smear and counts, finger or heel prick method of obtaining blood suffices, unless the investigations are to be actually done at a later stage and it is desirable to have the blood collected. In the latter situation and when larger amount of blood is required, a venipuncture, preferably from an antecubital vein, is indicated. Femoral puncture should, as far as possible, be avoided in view of its potential hazards.

For hemoglobin estimation, cell count, etc. 1 ml blood is collected in a 5 ml glass vial with 0.04 ml of the 10% EDTA disodium salt solution. The tests must be carried out within 12 hours of collection of blood.

Blood grouping and cross-matching requires 5 ml of blood in a 5 ml glass vial without any anticoagulant. The tests need to be done within 12 hours.

Such biochemical investigations as serum bilirubin, urea, proteins, cholesterol, LFT and electrolytes require 5 ml of blood in a 5 ml glass vial without any anticoagulant. Maximum preservation time is just 48 hours.

In case of prothrombin time, 4.5 ml blood is required to be collected in a glass tube containing 0.5 ml trisodium citrate. Maximum preservation time is sheer 2 hours.

For glucose, 5 ml blood is collected in a glass vial with 5 mg sodium fluoride. Maximum preservation time once again is 2 hours.

For enzymes (transaminases, phosphatase), 5 ml blood in a glass vial without any anticoagulant suffices. Maximum preservation time here too is just 2 hours.

Iron and its binding capacity need 5 ml of blood in acid washed tubes. The tests must be carried out as early as feasible.

For blood culture, 5 ml of blood is required for each of the two tubes, one with meat broth and the other nutrient broth with bile salts.

Hemoglobin

The most accurate method of estimating hemoglobin is photoelectric method.

The most popular method is, however, what is known as *acid-hematin method* which employs the Sahil hemoglobinometer. This method employs acid-hematin in a glass tube as a standard of comparison. The hemoglobin in the diluting tube is converted to acid-hematin by addition of N/10 HCl.

The method consists in placing N/10 HCl in the hemoglobinometer diluting tube up to the mark 10% (the lowermost mark). Blood is drawn in a hemoglobin pipette up to 20 cm mark and transferred into the diluting tube. The mixture is rinsed well.

After 10 to 20 minutes, distilled water is added drop by drop. Mixing is attained either by inverting the tube or with a glass rod. Addition of water is continued until the color of the diluting tube matches that of the standard provided with the hemoglobinometer.

The hemoglobin level (g/dl) is denoted by the reading against the lower level of the meniscus of the fluid in the diluting tube.

Hematocrit

Using a capillary pipette, the Wintrobe tube (the same employed for ESR) is filled up to the 100 mm mark with blood already treated with an anticoagulant and

centrifuged for 30 minutes at 2,500 rpm in a 15 cm radius centrifuge.

The hematocrit or packed cell volume (PCV) is denoted by the upper level of the red cell column in percentage.

Red Cell Count

Blood is drawn upto the 0.5 mark in the RBC pipette. This is followed by drawing in upto 101 mark the RBC diluting fluid. Taking care that the fluid does not spill out, the material is mixed well by rotating the pipette in a horizontal position:

Having discarded the first few drops of the mixture, charge the Neubauer counting chamber with it, ensuring that it does not overflow into the bigger grooves.

Count RBC in 80 smallest squares in the 4 comers and one central big square.

$$\begin{aligned} \text{RBC count} &= \frac{200}{0.02} \times \text{No. of cells counted} \\ &= 10,000 \times \text{"/cmm} \end{aligned}$$

Having dealt with hemoglobin, red cell count and PCV, let us summarize the erythrocyte indices:

1. Mean corpuscular volume (MCV)

$$\frac{\text{PVC liter}}{\text{RBC millions/cmm}} \text{ in cubic microns}$$

Normal value	78 to 94 cubic microns
High	macrocytic anemia
Low	microcytic anemia

2. Mean corpuscular hemoglobin (MCH)

$$= \frac{\text{Hemoglobin g/dl}}{\text{RBC millions/cmm}} \text{ micro micro g}$$

Normal value	27 to 32 micro g
High	macrocytic anemia
Low	microcytic anemia

3. Mean corpuscular hemoglobin concentration (MCHC)

$$= \frac{\text{Hemoglobin g/dl}}{\text{PCV}} \times 100\%$$

Normal	32 to 38%
Low (below 32%)	iron deficiency
It cannot exceed	38%.

4. Color index

$$\begin{aligned} &\text{Hemoglobin expressed as percentage} \\ &= \frac{\text{of normal (14.5 g\% as 100\%)}}{\text{RBC expressed as percentage of}} \\ &\quad \text{normal (5 million as 100\%)} \end{aligned}$$

Normal value	0.9 to 1.1
About unity	recent hemorrhage
Low	iron deficiency
Raised	megaloblastic anemia

Peripheral Blood Film

A clean dry slide is touched to a newly formed drop of blood from finger prick. One edge of a spreader slide is placed over the drop of blood smearing across the first slide should be done as shown in Figure 44.1. The smear is allowed to dry.

For malarial parasite both thick and thin smears should be prepared. Staining is done by Giemsa stain; thin smear needs earlier fixation with methanol for a couple of minutes.

For information concerning white and red cells, staining is done either with Leishman stain or Wright stain.

Total Leukocyte Count (TLC)

Blood is drawn into the WBC pipette up to the 0.5 mark. To make a dilution of 1:20, WBC fluid is drawn up to the 11 mark. These are mixed well.

Then, after discarding first 2 or 3 drops, WBC counting chamber is charged with this fluid in the same way as in case of the RBC count. Leukocytes are counted in 4 large corner squares.

$$\text{TLC} = 50 \times \text{No. of cells counted/cmm}$$

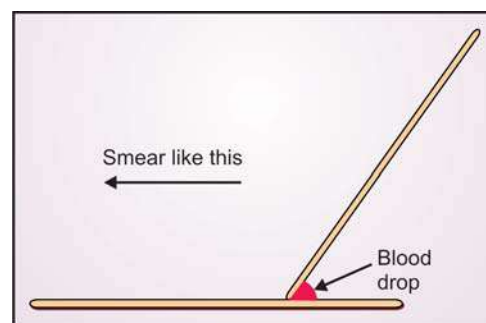

Fig. 44.1: Technique of preparing a peripheral blood film

Differential Leukocyte Count (DLC)

A well-stained peripheral blood film is examined under the oil immersion lens. At least 100 white cells with individual identification are counted proceeding from one side to the other. The individual cell types are expressed as a percentage.

Erythrocyte Sedimentation Rate (ESR)

ESR is a measure of the distance (mm) covered by the upper level of the red cell column in first hour.

Westergreen method consists in drawing into Westergreen pipette 0.5 ml of 3.8% sodium citrate solution upto the 200 mark. The pipette is then fixed in a stand and sealed to a cork at the bottom. ESR is read directly from the tube after 1 hour.

Wintrobe method consists in filling the Wintrobe tube up to the 100 mark with double oxalated blood. It is allowed to stand vertically in a stand for 1 hour. ESR is denoted by the reading on the tube.

Reticulocyte Count

In a glass test tube is poured a drop of cresyl blue solution followed by 2 drops of blood to be tested. These are mixed. After allowing to stand for 15 minutes, the tube is shaken gently.

Out of this stuff, one drop is taken on a glass slide and a smear is prepared. On microscopic examination under oil immersion lens, you would see reticulocytes as red cells with fine deep yellow granules in a network against pale blue RBC.

At least 100 red cells need to be counted to ascertain the number of reticulocytes which should be expressed as percentage of red cells.

Platelet Count

Rapid method consists in putting a drop of 14% magnesium sulfate solution over the finger puncture that has been earlier wiped dry and then touching a glass slide to the finger. The blood on slide is allowed to be smeared and then dried. It is stained with Wright stain*. Platelets are counted per 1000 red cells and platelet count is calculated from red cells.

* Wright stain for blood is prepared by grinding 100 mg of powdered stain in mortar. To the material is added 60 ml of alcohol. Evaporation of alcohol may cause precipitate formation on slide. In that case, 2 ml of methyl alcohol/10 ml of staining solution should be added

Direct method consists in drawing freshly prepared platelet solution* to the 0.5 mark in red cell pipette. Tip of the pipette is wiped and blood to 0.5 mark is drawn so that the platelet solution reaches the 1.0 mark. The tip is again wiped and the pipette is filled with platelet solution to the 101 mark. After mixing, count is conducted in hemacytometer as for red cell count.

URINE EXAMINATION

Collection

Make sure that collection of urine is made in a container that is chemically clear. Else, the results can be misleading. Medicine bottles which are not adequately washed may carry traces of syrup and be responsible for erroneous results.

Extra-care needs to be exercised in collecting urine in females, especially at puberty when contamination with vaginal discharge or menstrual blood may affect the results. Contamination with feces also needs to be avoided.

For collection of urine for culture, a clean catch mid-stream specimen in a sterile container with no preservative at all is a must.

Occasionally, a suprapubic puncture may be needed in sick neonates and small infants. Such a puncture is done under aseptic conditions 1 to 2 hours after the feed. The infant is placed in a supine position with hips and knees flexed to 90° and the thighs abducted. A 21 gauge needle attached to a 10 ml syringe is introduced vertically 1 to 2 cm above the symphysis pubis in the midline. Once the urinary bladder is pierced at a depth of 1.5 to 2 cm, you may aspirate urine in the syringe, and collect in the appropriate container.

Suprapubic puncture is safe. Occasionally, slight hematuria may occur.

Physical Examination

Color: Normal urine is yellow amber in appearance due to presence of urochrome. A fresh sample is clear but may become cloudy or turbid on standing. Presence of phosphates may render even a freshly-voided sample cloudy.

* Platelet solution is prepared by mixing 3.8 g sodium citrate, 0.2 ml neutral 40% solution of formaldehyde, and 0.05 g brilliant green cresyl blue in 100 ml of water

The change in color may point to the cause as clarified below:

Orange: restricted fluid intake leading to concentrated urine; fever; urobilin; drugs such as pyridium

Dark-brown: altered blood as in methemoglobinuria; porphyrin;

Red blood: beetroot, aniline dyes, drugs such as pyridium

Purple red: phenol; phenolphthalein

Portwine: porphyrin

Brownish black: Alkaptonuria

Greenish: Biliverdin, carbolic acid

Blue: Methylene blue, indigo blue

Reaction In order to find the pH of urine, one end of a indicator paper is dipped in a fresh sample of urine. The pH is indicated by noting the reading on standard scale against the resultant color.

Specific gravity A minimum of 40 ml of urine is put into a 50 ml measuring cylinder. The specific gravity is read from the urinometer which is gradually lowered into the container and allowed to be steady, ensuring that it is not in contact with the bottom or sides of the container.

Chemical Examination

Albumin For the conventional *boiling test*, test tube is filled 3/4th with the urine sample (filtered/centrifuged, if cloudy). If, on boiling the upper part of the tube content, a turbidity appears, protein or phosphates are present. In case of protein, the turbidity persists despite addition of a few drops of 10% acetic acid.

The presence of albumin can be further confirmed by warming equal amounts of urine and Exbon's sulfosalicylic acid, resulting in white cloudiness.

Grading of amount of proteinuria may be done as under:

Slight cloudiness	Traces	(0.005 to 0.01 g%)
Definite cloudiness	1+	(0.01 to 0.05g%)
Cloudiness along with flocculation	2+	(0.05 to 0.2g%)
Cloudiness along with remarkable flocculation	3+	(0.2 to 0.5g%)
Cloudiness along with precipitation	4+	(0.5 g% or more)

Another method of detecting proteinuria in the so-called, *dipstick test* (Uristix, Albustix), a very

sensitive tool that detects primarily albumin. It is reported as:

Negative traces

1+ closest to 30 mg/dl

2+ closest to 100 mg/dl

3+ closest to 300 mg/dl

4+ greater than 2 g/dl

False negative results may be because of highly concentrated urine sample, gross hematuria or contamination with chlorhexidine or benzalkonium.

For measuring *24-hour urinary protein*, having measured the total volume of the 24-hour collection, filtered it and brought the specific gravity below 1010 (if it is more) and added 10% acetic acid (if it is alkaline), fill the Esbach albuminometer tube with the sample up to the mark "U". To this, add Esbach reagent up to the "R". Having closed the tube with a rubber stopper, let the urine and reagent mix by inverting it a few times. After allowing the albumometer stay as such for 24 hours, note the level of the precipitate on the scale. This gives the 24-hour protein loss per liter of urine in grams. False negative results may be because of radiographic contrast medium or drug therapy with cephalosporin, penicillin, sulfonamide or tolbutamide.

Sugar To 5 ml of Benedict qualitative reagent in a test tube, add 0.5 ml (8 drops) of urine and shake well. Then, boil over naked spirit lamp flame for 2 minutes and allow to cool for 5 to 10 minutes. Blue coloration means no sugar. Clear green to brick-red indicates varying amount of sugar as shown below:

Clear green	Negligible
Green with precipitate	traces
Yellow with precipitate	0.5%
Orange with precipitate	1.0%
Brick-red with precipitate	2.0%

Remember, such drugs as aspirin, morphia, chloral hydrate, paraldehyde and PAS may reduce the Benedict agent even when there is no glycosuria.

Ketones Identification of ketones in urine is done by the Rothera test. About 10 ml of freshly voided urine in a test tube is saturated with Rothera mixture consisting of 99 parts of ammonium sulfate and 1 part of sodium nitroprusside. Pour 2 ml of strong ammonia gently along the side of the tube. Let it stand for 5 minutes. A purple color at the junction of urine and ammonia solution indicates positive reaction of ketone bodies.

Bile salts To a 8 to 15 cm column of fresh urine in a beaker, add finely powdered dry sulfur. If bile salts are present, the sulfur particles would sink. Else, these would float on the surface.

Bile pigments Fouchet test is the most sensitive for this purpose. It consists in adding 2.5 to 5 ml of barium chloride solution to 5 to 10 ml of fresh urine (if it is alkaline or neutral, acidify it with few drops of acetic acid). All this is mixed well and then filtered. To the precipitate (residue) on the filter paper add a drop or two of Fouchet reagent. A green color or a blue color indicates bilirubin—the former, the biliverdin, and the latter, the cholecyamin.

Occult blood Addition of 1 ml benzidine reagent (made by dissolving 4 g benzidine in 100 ml glacial acetic acid) and 1 ml hydrogen peroxide in 1 ml urine sample leads to blue coloration in case hemoglobin is present.

Porphyryns Addition of 0.5 ml Ehrlich reagent to 5 ml urine in a test tube may cause a distinct red color, indicating that either urobilinogen or porphobilinogen is present.

To this add 2 ml chloroform, mix and let the chloroform form the lower layer. If the chloroform layer remains colorless, urine contains only porphobilinogen. If, on the other hand, it becomes pink, urobilinogen is present in the urine sample.

Phenylpyruvic acid A drop of 10% ferric chloride is poured on a filter paper which had been made wet with urine and then allowed to dry. The resultant green color denotes increased urinary level of phenylpyruvic acid and thereby phenylketonuria (PKU).

Ferric chloride test may be negative in some cases of PKU. Also, it may be positive in other types of aminoaciduria and when such drugs as aspirin, phenothiazines, etc. have been administered.

Urine Microscopy

For microscopic examination, 10 to 12 ml urine is centrifuged for 5 minutes at 800 to 1,000 rpm. The supernatant is poured off, leaving behind 0.5 ml stuff in which sediment is resuspended by brisk agitation. Drops of sediment are placed on a slide and examined under the microscope with or without coverslip for RBC, WBC, epithelial cells, casts (red cell, white cell, mixed, granular, semigranular, hyaline), crystals (calcium oxalate, uric acid, cystine, urate, triple

phosphate, sulfonamide), bacteria, protozoa and yeasts. The results are expressed in terms of number per high power field.

Generally speaking, more than 5 red or white cells per high power field are considered abnormal. Whereas hyaline and granular casts may occasionally be a normal finding, the detection of tubular casts, especially in the presence of an abnormal number of red or white cells, certainly points to the existence of a renal disorder.

STOOL EXAMINATION

Collection

For routine examination (gross naked eye and microscopic for ova, cysts and trophozoites), stools need to be collected in a clean, dry and covered container, ensuring that there is no contamination with urine and the container is not sterilized by chemical disinfectants. If delay is anticipated in transporting the sample to the laboratory, it is a good idea to collect the sample in 3% neutral glycerol in 0.6% sodium chloride solution using phenolred as an indicator. The sample deserves to be discarded if the indicator color turns yellow.

Enterobius vermicularis is best detected by examination of the scappings of the anal and perianal region.

For stool culture, you must collect a rather large sample of mucus-containing stuff, preferably in a medium which not only stabilizes the pH but also prevents the death and dehydration of the bacteria before culture. Buffered glycerol saline broth is most suitable for this purpose. The composition of this broth is NaCl 4.2 g, K_2NHO_4 3.1 g, KH_2PO_4 1.2 g, glycerol 300 ml, water 700 ml, and phenol-red as the coloring agent.

Microscopy

Direct: Place a drop of sodium chloride solution at one end of a clean slide and a drop of Lugol iodine at the other end. To each, add a small portion of the stool sample. Each separation is covered with a cover slip carefully, ensuring there is no entry of the air bubbles.

Microscopic examination needs to be done under high as well as low power, shutting down the light to a great extent.

Concentration Since direct microscopy may miss ova and cysts when infection is not severe, it is often

necessary to employ one of the concentration techniques.

Formalin-ether sedimentation technique consists in emulsifying a portion of stools measuring 2 to 3 cm in diameter in 30 to 50 ml of saline. About 10 ml of emulsion is strained through two layers of wet gauze into a 15 ml centrifuge tube with a conical tip. This is centrifuged at a moderate speed for a few minutes and the supernatant decanted. The sediment is resuspended in fresh saline, centrifuged and decanted as before. The process may be repeated if necessary, especially in case supernatant is still cloudy. To the sediment is added 10 ml of 10% formalin. After mixing thoroughly, it is allowed to stand for 5 minutes. Then, 3 ml of ether is added. The tube is sealed and shaken vigorously.

Following centrifuging at low speed, 4 layers result. At the bottom is a small amount of sediment containing most of the parasites. Above that is a layer of formalin. On top of formalin layer is a plug of fecal debris. At top is a layer of ether.

The plug of debris from the sides of tube is freed by ringing with an applicator stick. The top three layers are decanted.

The remaining sediment is mixed with the small amount of fluid draining back from the sides of the tube. Finally, iodine or unstained mounts may be prepared in the usual manner for microscopic examination

Zinc sulfate centrifugal floatation technique consists in emulsifying 1 ml of stool sample in 10 ml of tap water. The emulsified sample is filtered through two layers of gauze. The mixture is centrifuged for 1 minute at 26000 rpm and the supernatant fluid poured off.

Then fresh water is added and the stuff mixed well and centrifuged again. This process is repeated 3 to 4 times, remembering that for the final emulsification 33% zinc sulfate solution is substituted for the saline. The suspension is centrifuged at top speed for 1 minute.

This way eggs and cysts rise to surface whereas trophozoites get destroyed.

Disturbing the supernatant as little as possible, several loopsful of the surface film are transferred to a glass slide. After adding a drop of iodine, mixing and covering with a coverslip, microscopic examination is carried out.

Figure 44.2 depicts microscopic appearance of ova/eggs/cysts of select protozoa and helminths in stool samples.

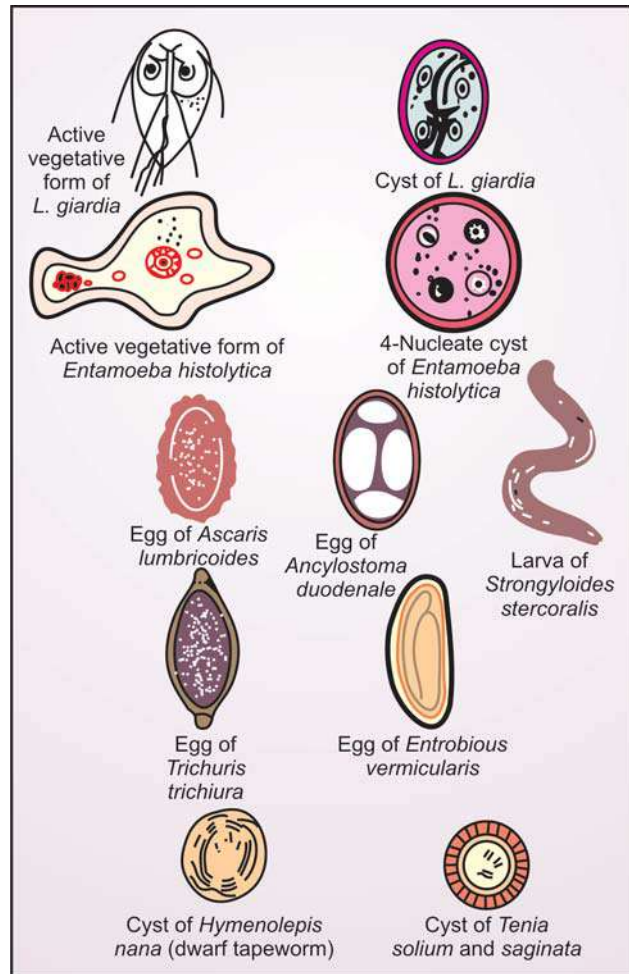

Fig. 44.2: Microscopic appearance of important protozoa and helminths in stool samples

Occult Blood

This may be detected by the benzidine test which consists in emulsifying 1 ml of stool sample in 10 ml of water containing 5 drops of glacial acetic acid and centrifuging for 1 minute to separate large stool particles. To 1 ml benzidine solution in a clean test tube is added 0.5 ml 0.6% hydrogen peroxide.

Allow it to stand for at least 5 minutes and preferably for 15 minutes for development of maximal color. Appearance of blue color denotes a positive reaction which should be categorized as below:

Faint blue	Traces
Blue green (slowly)	+
Green blue (rapidly)	++
Blue	+++

(immediately)
 Dark blue +++++
 (immediately)

Fat Globules

To a 1 to 2 ml pellet of stool sample on a glass slide, alcoholic solution of the dye, Sudan III or IV is added and mixed well with an applicator stick. Then is added 1 drop of 0.9% saline solution. The preparation is covered with a coverslip and examined under the microscope. Flat globules appear pink.

This rough method of testing for steatorrhea may be expressed as under:

0 to 2 globules	0 to +
3 to 5	+
Intermediate amount	+ to +++
Half of visible material	++++

Reducing Substances

In order to test for reducing substances (sugar) in suspected carbohydrate intolerance/malabsorption, a small amount of stool sample is taken in a clean test tube and to it four times the volume of water is added. The two are mixed well. The mixture is centrifuged.

The supernatant fluid is transferred to a test tube and to it is added 5 ml of Benedict qualitative reagent. Having shaken well, the mixture is boiled over a naked spirit lamp flame for a couple of minutes. Changes in color varying from green with precipitate to brick-red with precipitate denote presence of sugar between traces to +++.

7 Stool pH

Acidic pH is a hallmark of lactose intolerance. The test may be conducted by employing a wide range pH paper strip.

CSF EXAMINATION

The technique of obtaining cerebrospinal fluid (CSF) from the spine lumbar puncture (LP) is detailed in Chapter 43 (Pediatric Practical Procedures).

Collection

Make sure you collect the CSF in sterile capped vials and transport the vials quickly to the laboratory to safeguard against lysis of cells.

Examination

Pressure For this, employ the special manometer. The reading is most accurate when the child is relaxed with the neck and legs being extended. Normal range is 60 to 160 or even 200 mm of water.

Appearance Compare the color with that of distilled water against a white background. Note if it is clear (normal), turbid, purulent, xanthochromic (always abnormal after the neonatal period), or frankly hemorrhagic (traumatic tap, subarachnoid hemorrhage).

Microscopy To 4 drops of CSF, add 4 drops of CSF diluting fluid in a test tube. Wait for 10 to 15 minutes.

Charge the well-cleaned Neubauer counting chamber with stained fluid and cover with the coverslip. Focus the lines of the chamber under the microscope, first under low power and thereafter high power. Count the white cells, both polymorphs and lymphocytes, in the 4 large squares. It is advisable to count the cells thrice and take mean of the three readings so that technical error is minimized. The mean, thus obtained, multiplied by 5 gives the number of white cells/cu mm. Express also the percentage of polymorphs and lymphocytes.

For red cell count, the procedure is same except that (i) CSF is not diluted before charging the counting chamber, and (ii) Only one chamber may suffice for counting unless a very large number of red cells are present; in the latter situation counting may be done in 4 or 8 small squares. The number of red cells counted in a large square gives the number of red cells/cu mm in the CSF.

Protein To 2 ml of Pandy reagent in a test tube, add one drop of CSF. The line of CSF drop is followed by cloudiness which varies depending on the amount of globulins present. It may be graded from 0 to 4.

Sugar To 5 test tubes containing 1 ml of Benedict qualitative reagent, add 0.05 ml, 0.1 ml, 0.15 ml, 0.2 ml and 0.25 ml of CSF serially. Notice the green reduction after boiling each tube for 5 minutes. Occurrence of such a reduction in tube 1 means 50 mg% sugar, in tube 2 means 40 to 50 mg% sugar, in tube 3 means 30 to 40 mg% sugar, in tube 4 means 20 to 30 mg% sugar and in tube 5 means 10 to 20 mg% sugar. When none of the tubes shows any green reduction, it means the sugar content is less than 10 mg%.

The CSF sugar is normally about half of the blood sugar.

Culture It is advisable to always send a sample of CSF for culture for bacteria and, if indicated, for acid-fast bacilli (*Myc. tuberculosis*) or fungi.

Gram-staining When meningitis is on the card, CSF is centrifuged and a smear of the fluid made. It is allowed to dry and then subjected to Gram staining. gram-positive bacteria appear dark whereas gram-negative ones appear pink.

Ziehl-Neelsen Staining In suspected tuberculous meningitis (TBM), it is important also to micros-

copically examine a Ziehl-Neelsen stained preparation for AFB.

FURTHER READING

Articles/Chapters

1. King AWE. Pediatric laboratory tests in developing countries. *Asian J Lab Invest* 2000;8:234-242.
2. Morley JKS. *Pediatric Laboratory Techniques* (6th edn). Tokyo: United Publishers, 2003.

PART EIGHT

Pediatric Syndromes

Pediatric Syndromes

Suraj Gupte

- Aagenaes Syndrome:** A form of idiopathic familial intrahepatic cholestasis in which cholestasis is accompanied by lymphedema of the lower extremities.
- Abetalipoproteinemia (Acanthocytosis):** Progressive ataxia, retinitis pigmentosa, malabsorption, hypocholesterolemia, abetalipoproteinemia, thorny red cells (acanthocytes); autosomal recessive.
- Acanthocytosis:** See abetalipoproteinemia.
- Acrodermatitis Enteropathica (Brandt Syndrome):** Chronic diarrhea (frequently steatorrheic), dermatosis usually around body openings, alopecia, paronychia; frequently conjunctivitis and blepharitis; zinc deficiency; familial; autosomal recessive.
- Adenosine-deaminase Deficiency:** Severe combined immunodeficiency (SCID), low enzyme levels in red cells; autosomal recessive.
- Alagille Syndrome (Arteriohepatic Dysplasia):** Unusual facial features like broad forehead, deeply-set, widely-spaced eyes, long, straight nose, underdeveloped mandible; ocular abnormalities (posterior embryotoxin), cardiovascular abnormalities (pulmonary stenosis, tetralogy of Fallot), vertebral arch defects (peripheral butterfly vertebra), tubulointerstitial nephropathy, growth retardation, defective spermatogenesis; complications include neurologic evidence of vitamin E deficiency, pruritus, xanthomata.
- Albright Syndrome (Fibrous Dysplasia of Bone):** Skin pigmentation, short stature, precocious puberty, areas of osseous rarefaction resembling cysts, advanced bone age, fractures.
- Alice-in-Wonderland Syndrome:** Perceptual distortion of shape, size, color and reciprocal position of objects; seen in EBV infection, epilepsy, hallucinogenic drugs, schizophrenia, migraine, etc.
- Alpha1-antitrypsin Deficiency:** Persistent jaundice (obstructive) in a newborn, cirrhosis, adult emphysema; autosomal recessive.
- Ataxia Telangiectasia:** Progressive ataxia, choreo-athetosis, telangiectasia of conjunctiva, face, elbows and knees; autosomal recessive.
- Beckwith Syndrome (Beckwith-Wiedemann Syndrome):** Macroglossia, macrosomia, omphalocele, hyperplasia of kidneys and pancreas, proneness to Wilms' tumor; hypoglycemia, prominent facial nevus flammeus.
- Berger Disease:** Gross hematuria (intermittent), benign focal glomerular lesion.
- Blackfan-Diamond Anemia:** Congenital pure red cell hypoplastic anemia.
- Bloom Syndrome:** Dwarfism, congenital telangiectatic erythema over malar area of face, nose and lips, photosensitivity, small narrow face, high-pitched voice, protruding ears; diminished immunoglobulins; high frequency of chromosomal breakage.
- Blue Diaper Syndrome:** Failure to thrive (FTT), blue discoloration of diaper right from early infancy, irritability, constipation, infections, recurrent fever of unknown etiology, high blood urea, hypercalcemia, extensive nephrocalcinosis.
- Brandt Syndrome:** See acrodermatitis enteropathica.
- Caffey Disease (Infantile Cortical Hyperostosis):** Nonsuppurative, tender, painful swellings over the flat and tubular bones, (subcutaneous tissue and joints are spared), irritability, fever, anemia,

leukocytosis, high ESR and alkaline phosphatase; X-ray of bones reveals cortical hyperostosis; self-limited; corticosteroids indicated in advanced cases.

Caudal-Regression Syndrome: Anorectal malformations, urogenital anomalies, varying degrees of lumbosacrococcygeal agenesis; most extreme form is represented by mermaid fetus (sirenomelia); supposed to be an embryonal defect dating back to the primitive streak stage during third week of intrauterine life; recently diabetes mellitus has been incriminated as a possible cause.

Chédiak-Higashi Syndrome: Semialbinism, photophobia, nystagmus, excessive sweating, generalized lymphadenopathy, hepatosplenomegaly, pale optic fundi, pyogenic infections, progressive neurologic manifestations; grey-green granules in the cytoplasm of neutrophils and extremely large red granules in the eosinophils and myelocytic cells of the marrow; familial, autosomal recessive; fatal.

Chotzen Syndrome (Cranio-oculodental Syndrome): Characteristic facies with asymmetry, low hairline, ptosis parrot-beaked nose, partial craniosynostosis (specially involving coronal or sphenobasilar sutures).

Chronic Granulomatous Disease: Frequent pyogenic infections; nitroblue tetrazolium test; X-linked recessive.

Cleidocranial Dysostosis: Absent clavicles, delayed closure of fontanelles; autosomal dominant.

Cockayne Syndrome: Dwarfism, ankylosis, kyphosis, pinched facies, thin nose, sunken eyes, prognathism, mental retardation, partial deafness, ataxia, photosensitivity, optic atrophy, attenuation of retinal vessels; hereditary.

Congenital Chloridiarrhea: Neonatal diarrhea, low serum chloride and potassium, metabolic alkalosis; autosomal recessive.

Crigler-Najjar Syndrome: Type 1-severe neonatal jaundice, autosomal recessive. Type 2-mild neonatal jaundice, autosomal dominant, responds to phenobarbital. **Cause:** glucuronyl transferase deficiency.

Cystinosis: Failure to thrive, cystine crystal deposits in eyes, marrow and reticuloendothelial system; autosomal recessive.

Dermatitis Herpetiformis: Skin eruptions (vesicular and itching), malabsorption consistent with celiac

disease. Skin lesions show slow response to elimination of gluten from diet.

Dermochondrocorneal Dystrophy of Francois: Xanthoma-like skin nodules, abnormal ossification of cartilage of hands and feet, reduced visual acuity due to white, irregular corneal opacities.

Diastematomyelia: Progressive paralysis, anesthesia, neurogenic bowel and bladder due to the traction caused by the bony spur through the lower spinal cord.

DiGeorge Syndrome: Defects of heart and face, repeated infections, neonatal tetany; absent thymus and parathyroids; normal immunoglobulins.

Donohue Syndrome (Leprechaunism): Hairy old-man's appearance, wrinkled skin, hypertelorism, prominent eyes, broad and protruding nose, large and lowset ears; in females nipples, labia minora and clitoris are hyperplastic.

Dubin-Johnson Syndrome: Intermittent obstructive jaundice, black pigment in liver biopsy; autosomal recessive.

Ebstein Anomaly: Tricuspid valve set in right ventricle, large square cardiac shadow, abnormal ECG and rhythms.

Ehlers-Danlos Syndrome: Hyperelastic and easily scarred skin, easy bruising; hypermobility and recurrent dislocation of joints; of 10 types, autosomal dominant is commonest.

Evans Syndrome: Hemolytic anemia, thrombocytopenia.

Fabry Syndrome: Cutaneous papules and macules, hyperkeratotic skin particularly in areas of genitalia and thighs.

Familial Dysautonomia (Riley-Day Syndrome): Absence of tears, poor perception of painful stimuli, excessive drooling, sweating, skin blotching, paroxysmal hypertension; autosomal recessive.

Fanconi Anemia: Congenital malformation of bones of forearm, dwarfism, mental retardation, aplastic anemia developing in toddler; autosomal recessive.

Fetal-alcohol Syndrome: Prenatal onset and persistence of growth deficiency for length, weight and head circumference, facial abnormalities (short palpebral fissure, epicanthal fold, maxillary hypoplasia, micrognathia, thin upper lip), cardiac defects (septal), minor limb and joint abnormalities, growth and mental deficiency. **Cause:** High level of alcohol ingestion during pregnancy.

- Fetal Caffeine Syndrome:** Low birth weight, developmental delay, multiple congenital malformations. **Cause:** Daily/consumption of over 8 to 10 cups of caffeine drink during pregnancy, providing over 1,000 mg caffeine/day.
- Fragile X Syndrome:** Long face, prominent forehead, large ears, prominent jaw, macroorchidism; behavioral problems, even mental retardation; **Cause:** a rare folate-sensitive fragile site in band Xq 27.3; dominant X-linked disorder; gene stands isolated.
- Freeman-Sheldon Syndrome (Whistling-face Syndrome, Craniocarpotarsal Dysplasia):** Stiff, mask-like facies with flattened facial bones, ptosis, blepharophimosis, narrow, small nose, high-arched palate, microstomia with small tongue and thin protruding lips.
- Friedreich Ataxia:** Cerebellar ataxia due to spinocerebellar degeneration, pes cavus, myocarditis, followed by scoliosis later, at times diabetes insipidus; autosomal recessive.
- Fröhlich Syndrome:** Obesity, hypogonadism, growth retardation, diabetes insipidus; **Cause:** usually intra-cranial tumor.
- Gilbert Syndrome:** Fluctuating unconjugated hyperbilirubinemia (mild) which is aggravated by administration of nicotinic acid; autosomal dominant.
- Goldenhar Syndrome (Oculoauriculovertebral Dysplasia):** Epibulbar dermoids, preauricular skin appendages, malformations of mandible, sometimes hemivertebrae or fused vertebrae.
- Goltz-Gorlin Syndrome (Focal Dermal Hypoplasia):** Atrophy and linear pigmentation of skin with occasional papillomas, alopecia, dystrophy, malformation of teeth, squint, colobomas of iris, choroid and retina, asymmetry of nasal cartilage, digital anomalies.
- Gulf Syndrome:** Hypervitaminosis A and D resulting from excessive intake of vitamins A and D in fish oil pearls marketed by Gulf countries.
- Gray Baby Syndrome:** Following 2 to 4 days' administration of chloramphenicol may occur such manifestations in the newborn as vomiting or regurgitation, refusal to suck and abdominal distension. In another day or so, the baby develops ashgray color and becomes limp and severely dyspneic. He may die within one to two days of onset of manifestations.
- Hallermann-Streiff Syndrome (Oculomandibulofacial Dyscephaly):** Aged, wrinkled appearance, microphthalmia, bilateral cataract, hypomandibulosis, hypotrichosis, parrot-like facies, microcephaly, dental defects, and motor and mental retardation.
- Hallervorden-Spatz Disease:** Progressive rigidity and dementia beginning in late childhood; **Cause:** deposits of iron-containing pigment in globus pallidus and substantia nigra.
- Hand-Schüller-Christian Disease:** Histiocytic infiltration causing triad of bone lesions, exophthalmos and diabetes insipidus.
- Hartnup Disease:** Intermittent ataxia, photodermatitis, psychosis, generalized neutral aminoaciduria; autosomal recessive.
- Hyper-IgE Syndrome (Job Syndrome):** Recurrent Staph, abscesses, skin pigmentation, chronic eczema, red hair; occurs exclusively in boys; IgE levels remarkably high; a cell-mediated immunity defect.
- Jervell-Lange-Nielsen Syndrome (Cardioauditory Syndrome):** Congenital perceptive deafness (symmetrical), cardiac conduction defects, syncopal attacks, sudden death; autosomal recessive.
- Job Syndrome:** See hyper IgE syndrome.
- Kallmann Syndrome:** Anosmia, gonadotrophin lack; X-linked recessive.
- Kartagener Syndrome:** Dextrocardia (usually situs inversus totalis), chronic sinusitis, chronic bronchitis/bronchiectasis.
- Kasabach-Merritt Syndrome:** Giant hemangioma, platelet trapping and consumption.
- Kawasaki Disease (Mucocutaneous Lymph Node Syndrome):** Prolonged high pyrexia, skin and mucous membrane lesions. Cervical adenopathy; arthralgia/arthritis, pyuria, proteinuria, mild hepatitis, aseptic meningitis in some; cardiovascular involvement infrequent.
- Larsen Syndrome:** Multiple congenital dislocations, including anterior dislocation of the tibia or the femur, flat facies, frontal bossing, hypertelorism, depressed nasal bridge, talipes equinovarus.
- Laurence-Moon-Biedl Syndrome:** Obesity, hypogonadism, short stature, retinitis pigmentosa, polydactyly, mental retardation: autosomal recessive.
- Lazy leukocyte Syndrome:** Gingival stomatitis, recurrent upper respiratory infection, otitis, skin

infection, intractable persistent pyrexia, leukopenia; a neutrophil defect leading to absence of polymorphonuclear motility from bone marrow.

Leigh Syndrome: Subacute necrotizing encephalopathy with progressive neurologic deterioration; early manifestations: feeding difficulties, feeble or absent cry, floppiness; late manifestations: optic atrophy, seizures; autosomal recessive.

Leiner Disease: Severe seborrheic eczema, chronic diarrhea, failure to thrive, bacterial infections, abnormal C5 complement function.

Léri-Weill Syndrome (Dyschondrosteosis): Short forearms with Madelung deformity and often short lower legs.

Lesch-Nyhan Syndrome: Psychomotor deterioration progressing to choreoathetosis and self-mutilation by 2 to 3 years, abdominal pain, uric acid crystaluria, renal failure, elevated plasma uric acid, absence of an enzyme; X-linked recessive.

Letterer-Siwe Disease: Histiocytic infiltration leading to hepatosplenomegaly, purpuric seborrheic eczema.

Lowe Syndrome: Cataract, buphthalmos, mental retardation, aminoaciduria; X-linked recessive.

Lucey-Driscoll Syndrome: Familial transient unconjugated hyperbilirubinemia: *Cause:* glucuronyle transferase inhibitor in serum of baby and mother.

Maroteaux-Lamy Syndrome (Pyknodysostosis): Dwarfism, delayed closure of fontanel, dysplasia of skull, cortical densities of the bones, short digits with wrinkled skin and nail, parrot-like nose, partial adontia.

McCune-Albright Syndrome: Precocious puberty, fibrous dysplasia of bones, feathery-edged pigmentation.

Meckel Syndrome: Post-axial polydactyly, encephalocele, cystic dysplastic kidneys and hepatic fibrosis; autosomal recessive disorder.

Menkes Kinky Hair Disease/Syndrome: Woolly, curly hair, psychomotor deterioration, seizures, low plasma copper and ceruloplasmin; X-linked recessive.

Mikity-Wilson Syndrome (Bubbly-lung Syndrome): Respiratory distress, expiratory grunting, chest retraction; cyanosis; occurs in premature infants shortly after birth; X-ray chest shows combined segmental collapse and overinflation.

Munchausen Syndrome by proxy: Induced or fabricated symptoms in respect of the child by parents, usually by mother connected with medical profession.

MURC Association: An association of Mullerian duct aplasia/hypoplasia (MU) manifesting as genital anomalies, renal agenesis/ectopy (R), and fusion of cervicothoracic vertebrae (C); probable teratogenic origin.

Myotonic Dystrophy: Infantile hypotonia, feeding difficulties, mental retardation, cataracts, myocarditis, frontal baldness (later): autosomal dominant.

Omenn Syndrome: Profound susceptibility to infection, T-cell infiltration of skin, gut, liver, and spleen leading to exfoliative erythroderma, lymphadenopathy, hepatosplenomegaly, and intractable diarrhea. Remarkable eosinophilia and persistent leukocytosis in association with combined immunodeficiency. It is fatal, autosomal recessive.

Optopalatodigital Syndrome: Small nose, hypertelorism, broad nasal root, frontal and occipital bossing, cleft palate, growth and mental retardation, irregular fingers and toes, limited elbow extension and wrist supination.

Osteopetrosis (Marble Bone Disease): Thickened fragile bones, pancytopenia, splenomegaly; autosomal recessive.

Peutz-Jeghers Syndrome: Melanotic macules on lips and mucous membranes, polyposis of small intestine; autosomal dominant.

Prader-Willi Syndrome: Obesity, mental retardation, hypogonadism, cryptorchidism.

Progeria: Low birthweight, early growth failure, premature senility, remarkable loss of subcutaneous fat, bald head, absence of eyebrows, atrophic nails, osteoarthritis, arteriosclerosis.

Reifenstein Syndrome: Hermaphroditism due to defective virilization from reduced end-organ responsiveness.

Rett Syndrome: A previously normal child begins showing at 7 to 8 months of age early communication dysfunction with autistic features, dementia, loss of purposeful use of hands, typical hand movements, ataxia and seizures; by age 10 to 12 bedridden because of development of hypertonia and flexed posture; occurs exclusively

in females; believed to be a primary abnormality in central monoaminergic system.

Rieger Syndrome: Hypodontia, iris anomalies, synechiae extending from the iris to the cornea.

Right Middle Lobe Syndrome: Subacute or chronic pneumonitis, bronchial obstruction, atelectasis; bronchiectasis may result. In addition to pulmonary suppuration, it may be related to asthma or congenital anomalies of bronchi.

Riley-Day Syndrome: See familial dysautonomia.

Ritter Disease: Bright erythematous eruption over face, neck, axilla and groin changing into a wrinkled appearance with ill-defined flaccid bullae filled with clear fluid; areas of epidermis separate when gently stroked (Nikolsky sign); within 2 to 3 days postinflammatory desquamation; conjunctivitis, pharyngitis, stomatitis; caused by *Staphylococcus aureus*, usually group 1.

Rothmund Syndrome: Poikiloderma, cataracts, small saddle nose, microdontia, hyperkeratosis of palms and soles, mental retardation.

Rotor Syndrome: Neonatal jaundice which persists; autosomal dominant.

Rubinstein-Taybi Syndrome (Broad Thumb-Hallux Syndrome): Growth and mental retardation, characteristic facies with beak-like nose, narrow, high palate, prominent forehead, lowset and slightly anomalous ears, palpebral fissures, showing anti-mon-goloid slant, abnormally wide thumbs and first toes.

Russet-Silver Syndrome: Short stature, asymmetry of the body, triangular face, clinodactyly, early sexual development.

Schmidt Syndrome: Idiopathic adrenal insufficiency, hypothyroidism, insulin-dependent diabetes mellitus, hypoparathyroidism, gonadal failure; and autoimmune endocrinopathy.

Short-rib Polydactyly Syndromes: Hydropic appearance, GIT and CVS anomalies, dysplastic kidneys, genital hypoplasia, narrow thorax; micromelia, polydactyly; uniformly fatal at or shortly after birth; prenatal diagnosis possible by radiography or ultrasound; autosomal recessive inheritance.

Sjögren-Larsson Syndrome: Mental retardation, spastic paralysis, congenital ichthyosis.

Smith-Lemli-Opitz Syndrome: Anteverted nostrils, ptosis, syndactyly of second and third toes, hypospadias and cryptorchidism, growth and mental retardation.

Sotos Syndrome (Cerebral Gigantism): Excessive growth (height and weight are significantly large), mild mental retardation, acromegalic facies.

Spasmus Nutans: Abnormal posture and movements of head, nystagmus.

Subacute Sclerosing Panencephalitis (SSPE): Progressive dementia, spasticity, seizures (especially myoclonic), EEG showing "burst-suppression" pattern; measles antibodies in CSF; supposed to be secondary to an old attack of measles.

Tangier Disease: Large lobulated tonsils with red, orange or yellowish banding, hepatosplenomegaly, lymphadenopathy, peripheral neuropathy, loss of pain and temperature sensation; abnormally low plasma cholesterol and nearly absent alphasipoproteins.

TAR Syndrome: Thrombocytopenia with absent radius, autosomal recessive.

Turner Syndrome: At birth: Characteristic edema of dorsa of hands and feet, loose skin folds at nape of neck, LBW, low length. In childhood: Webbing of neck, low posterior hairline, small mandible, prominent ears, epicanthal folds, high-arched palate, broad chest, cubitum valgum, hyperconvex fingernails, short stature. In adolescents: Sexual infantilism, pigmented nevi, CVS malformations, genitourinary malformations, sensorineural hearing deficit, inflammatory bowel disease and recurrent GI bleeding from telangiectasia become pronounced.

Waardenburg Syndrome: Lateral displacement of the inner canthi, prominence of root of the nose, hyperplasia of the medial portion of the eyebrows, heterochromic iris, white forelock or early graying, congenital sensorineural deafness; autosomal recessive dominance.

WDHA Syndrome: Watery diarrhea, hypokalemia, acidosis; associated with a non-B cell tumor (VI Poma) of pancreas.

Weber-Christian Syndrome: Recurrent episodes of fever nonsuppurative nodules in the subcutaneous tissues.

Williams' Syndrome: Supravalvular aortic stenosis, mental retardation, elfin facies (broad forehead, flat nose, long upper lip, rounded cheeks, hypertelorism); associated with idiopathic hypercalcemia of infancy.

Wilson-Mikity Syndrome: LBW, prematurity, severe apnea on day 2 to 5, atelectasis, reduced functional residual capacity needing therapy with CPAP or mechanical ventilation.

Wiskott-Aldrich Syndrome: Eczema, thrombocytopenic hemorrhage, increased vulnerability to infections due to immunodeficiency; X-linked recessive trait.

Wolff-Parkinson-White (WPW) Syndrome: Short P-R interval, slow uptake of QRS (delta wave). May be associated with Ebstein anomaly, corrected TGV. Mostly present in normal heart.

Wolfram Syndrome: Insulin-dependent diabetes mellitus (IDDM), optic atrophy, deafness, neurogenic bladder; autosomal recessive inheritance.

Wolman Disease: Failure to thrive, vomiting, diarrhea, organomegaly, adrenal calcification, leukocyte acid lipase absent; autosomal recessive.

Wooly Hair Disease: Characteristically curly abnormal hair at birth with (i) other ectodermal structures and hair color are normal (autosomal dominant form), (ii) scalp hair of bleached appearance and body hair short and pale (autosomal recessive form), and (iii) only a portion of scalp hair is fine and light-colored and shows poor growth (wooly hair nevus).

X-linked Severe Combined Immunodeficiency syndrome (XSCID): The infant has point or deletional mutations in IL-2R, Genetic defect affects B- and NK-lineage cells as also T cells.

Yeast syndrome: Fatigue, depression, anorexia, constipation, diarrhea and other GI complaints, lack of concentration. It is believed by some to be related to *Candida* infection.

Yellow Nail Syndrome: Pleural effusion, lymphedema, discolored nails; sometimes bronchiectasis. It is related to pulmonary circulation.

Young Syndrome: Sinusitis, bronchiectasis, azoospermia; rarely clubbing.

Zellweger Syndrome (Cerebrohepatorenal syndrome): Hypotonia, flat facies with high forehead, low birth-weight, jaundice developing in first few days or weeks, psychomotor development delayed; death usually occurs by sixth month of age.

Zellweger-like syndrome: Physical findings resembling Zellweger syndrome plus multiple peroxisomal enzyme deficiencies. Hepatic peroxisomes have normal function.

Zinsser-Cole-Engman Syndrome (Congenital Dyskeratosis): Nail atrophy, poikiloderma-like skin changes with grayish-brown pigmentation and telangiectasis; hyperhidrosis and hyperkeratosis of palms and soles; acrocyanosis and bullae over hands and feet; stomatitis and glossitis; blepharitis, ectropion and watering of eyes; scanty hair; hypoplastic anemia; squamous-cell carcinoma and hematologic defects may prove fatal; X-linked inheritance, affecting only males.

Zollinger-Ellison Syndrome: Peptic ulceration, hypertrophy of gastric mucosa and excessive acid secretion due to non-beta-islet-cell adenoma.

FURTHER READING

Articles/Chapters

1. Tarleton JC, Saul RA. Molecular genetic advances in fragile X syndrome. *J Pediatr* 1993;122:169.
2. Wilson E, Samuel K. New syndromes. *Bull Pediatr Neonatol* 2000;3:122.

Books/Monographs

1. Habel A. *Aids to Pediatrics* (2nd edn). London: Churchill Livingstone 1988.
2. Wilson JF. *Synopsis of Syndromes*, (4th edn). London: Smith & Smith, 2000.

PART NINE

**Pediatric
Drug
Dosages**

Pediatric Drug Dosages

Lalita Bahl, Suraj Gupte

- Acetaminophen (Calpol, Crocin, Metacin)** 40 to 50 mg/kg/ day (O) in 4 divided doses. Single dose 15 mg/kg (O). IM dose 5 mg/kg.
- Acetazolamide (Diamox):** 8 to 30 mg/kg/day (O) in 3 to 4 divided doses in epilepsy, cerebral edema and glaucoma; 5 mg/kg/day as a diuretic in CCF.
- Acetylsalicylic acid (Aspirin):** 65 mg/kg/day (O) in divided dose as an antipyretic; 65 mg/year of age/dose (O) as analgesic; 65 to 130 mg/kg/ day (O) in divided dose for rheumatic fever.
- Actinomycin D:** 15 mcg/kg/day (IV) for 5 days only.
- ACTH:** 1.8 Units/kg/day (SC, IM).
- Adenosine:** 0.05 to 0.25, g/kg dose (IV)
- Acyclovir (Zovirax):** Topical-5% ointment for genital, labial and corneal herpes. Oral - High dose of 800 mg to low dose of 200 mg 5 times daily for 5 days in herpes simplex and varicella (chickenpox). Intravenous-5 to 10 mg/kg/dose every 8 hour in neonatal herpes, varicella pneumonia and immunocompromised states with superadded varicella or herpes simplex for 10 days.
- Adrenaline (Epinephrine, 1 in 1,000):** 0.01 ml/kg/dose (SC) with a maximum of 0.6 ml/dose. Repeat every 10 to 20 minutes for 3 to 4 times or every 3 hours p.r.n.
- Albendazole (Alminth, Zentel):** 200 mg for up to 2 years, 400 mg beyond 2 years. Single dose suffices for most helminths except *Str. stercoralis* and tapeworms which need 3 days course. *Giardia lamblia* needs a 5-days course.
- Albumin:** 2 ml/kg/dose (IV).
- Albuterol:** 0.1 to 2 mg/kg/day (O) in 3 to 4 divided doses.
- Allopurinol (Zyloric, Ciploric):** 10 to 20 mg/kg/ day in 3 divided doses.
- Alprostadiol:** 0.05 to 0.1 µg/kg/min as a continuous IV infusion, may be gradually increased to a max of 0.4 µg/kg/min depending on the response.
- Aluminium hydroxide (Aludrox):** For treatment of peptic ulcer 5 to 15 ml/dose every 3 to 6 hours. For prophylaxis of gastrointestinal bleed 2 to 5 ml every 1 to 2 hour.
- Amikacin (Mikacin, Ivimicin):** Neonates above 7 days: 30 mg/kg/day in 3 divided doses. Neonates under 7 days: 15 mg (weight below 2 kg) and 10 mg (weight above 2 kg)/kg/day, in 2 divided doses.
- Aminophylline:** 4 to 6 mg/kg/dose (IV, IM), 10 mg/kg/dose (O). Repeat every 8 hours.
- Aminosidine sulfate (Gabbramicina):** 10 to 20 mg/kg/day (IM) in 2 to 3 divided doses.
- Amitriptyline (Tryptanol sarotena):** 1.5 mg/kg/ day (O).
- Amodiaquin (Camoquin):** 20 mg/kg/day (O) as single dose. If maintenance dose needed, give 8 mg/kg/day.
- Amoxicillin (Amoxyl, Lamoxy, Novomax, Flemipen, Comoxyl, Wymox):** 20 to 40 mg/kg/day in 3 divided doses. 50 to 100 mg/kg/day (IM, IV) in 3 divided doses in serious infections. For meningitis, 200 to 400 mg/kg/day (IV).
- Amoxicillin with clavulanic acid (Augmentin):** See Amoxicillin for calculation of dose.
- Ampicillin (Roscollin, Campicillin):** 50 to 400 mg/kg/day (O, IM, IV) in 4 divided dose.
- Ascorbic acid (Vitamin C):** 100 to 500 mg/day (O).
- Astemizole (Sterniz):** 0.2 mg/kg (O) as a single dose as first thing in the on empty stomach.
- Atenolol:** 0.8 to 1.5 mg/kg/day to a max of 2 mg/kg/day orally.

- Atropine sulfate:** 0.01 mg/kg/dose (O or SC) with a maximum of 0.4 mg/dose. Repeat every 4 to 6 hours p.r.n.
- Atropine sulphate:** 0.02 to 0.05 mg/kg/dose as antidote to organophosphorous poisoning.
- Azathioprine (Imuran):** 1 to 3 mg/kg/day (O).
- Azithromycin dihydrate (Azithral):** 10 mg/kg (O) once a day for 3 days.
- BAL (Dimercaprol):** 2.5 mg/kg/dose (IM) 1st, 2nd and 3rd dose every 4, 6 and 12 hours respectively. Follow by -a single daily injection for the subsequent 10 days.
- Beclomethasone:** 1 to 2 inhalations 2 to 4 times a day to a max. of 10 puffs (42 µgm/puff).
- Beractant (lung surfactant):** 4 ml/kg via endotracheal tube (slow infusion).
- Betamethasone dipropionate (Vanceril inhaler):** 1 to 2 inhalations 6 to 8 hourly (each inhalation providing about 50 mcg betamethasone).
- Bephenium hydroxynaphthoate (Alcopar):** 2.5 g for children under 5 years, 5 g for children above 5 years (O) on empty stomach.
- Budesonide:** Pulmicort inhaler 1 to 2 puffs a day for children over 6 years.
- Busulfan (Mylelran):** 0.006 mg/kg/day (O).
- Calcitriol:** 0.01-0.05 mcg/kg/day
- Calcium gluconate:** 500 mg/kg/day (O) as 5 to 10% solution; 200 mg/kg/dose (IV) with a maximum of 2 g.
- Calcium lactate:** 500 mg/kg/day in 3 to 6 divided doses.
- Captopril (Aceten, Acezide, Aceten):** 0.1 to 0.4 mg/kg/day in 2 to 4 divided doses. Increase slowly to a maximum of 2.0 mg/kg/day.
- Carbamazepine (Tegretol, Mezetol):** 10 to 20 mg/kg/day (O).
- Carbenicillin (Carbelin):** 50 to 400 mg/kg/day (IM, IV) in 4 to 6 divided doses.
- Carbimazole (Neomercazole):** 1-2 mg/kg/day (O) in 3 divided doses.
- Cefaclor (Keflor):** 20 to 40 mg/kg/day (O) in 3 divided doses.
- Cefadroxil (Cefadrox, Lydroxil):** 30 mg/kg/day in 2 divided doses.
- Cefatoxime (Claforan, Omnatax):** 100 to 200 mg/kg (IM, IV) in 2 to 4 divided doses.
- Cefazolin (Cefamazin, Cefazin, Orizolin):** 25 to 50 mg/kg/day (IM, IV) in 2 to 4 divided doses.
- Cefixime:** 8 mg/kg (O) in 2 divided doses.
- Cefoperazone sodium:** 50 to 200 mg/kg/day (IM IV) in 2 to 3 divided doses.
- Cefpodoxime proxetil:** 8 to 10 mg/kg/day (O) in 2 divided doses.
- Ceftazidime (Fortum):** Under 2 months—25 to 60 mg/kg/day (IM, IV) in 2 divided doses. Above 2 months—30 to 100 mg/kg/day (IM, IV) in 2 or 3 divided doses.
- Ceftibuten (Procadex):** 9 mg/kg once a day.
- Ceftriaxone (Monocef):** 20 to 80 mg/kg/day (IM) in 1 or 2 doses.
- Cefuroxime axetil (Altacef, Cefogen):** 25 to 50 mg/kg/day (IM, IV) in 2 divided doses.
- Cephalexin (Sepexin, Sporidex):** 25 to 100 mg/kg/day (O) in 4 divided doses.
- Cephaloridine (Sporidine, Ceporan):** 15 to 30 mg/kg/day (IM, IV) in 2 to 3 divided doses. In severe infections, especially with Gram-positive organisms, dose is 40 to 60 mg/kg/day; 1 mg/kg/dose (IT).
- Cetirizine (Alerid):** 2-6 years 2.5 to 5 mg, 6 - 12 years 5 to 10 mg (O) as a single dose; 0.2 mg/kg/day (O) as a single dose.
- Chloral hydrate:** 5 mg/kg/dose (O or rectally) for sedation; 50 mg/kg/day for hypnosis with a maximum of 2 g.
- Chlorambucil (Leukeran):** 0.1 to 0.2 mg/kg/day (O).
- Chloramphenicol (Chloromycetin):** 50 to 100 mg/kg/day (O, IM, IV) in divided dose. The dose in newborn, especially in first two weeks of life, should be 25 mg/kg/day.
- Chlordiazepoxide (Librium):** 0.5 mg/kg/day (O).
- Chloroquine (Nivaquine, Lariago, Emquin):** 10 mg/kg/day (O); 5 mg/kg (IM).
- Chlorpromazine (Largactil):** 0.5 to 1 mg/kg/dose (O or IM), 2 to 3 mg/kg/day in 4 to 6 divided doses.
- Chlorthiazide (Diuril):** 7 to 40 mg/kg/day (O or IV) in 2 divided doses.
- Chlorpheniramine:** 0.35 mg/kg/day (O or SC) in 4 divided doses.
- Cimetidine:** 20 to 40 mg/kg/day in divided doses.
- Ciprofloxacin (Cifran, Ciplox, Ciprobid):** 20 to 30 mg/kg/day (O) and 10 to 20 mg/kg/day (IV) in 2 divided doses.
- Cisapride:** 0.8 mg/kg/day (O) in 4 divided doses.
- Clarithromycin:** 10 to 15 mg/kg/day in 2 divided doses.

- Clindamycin (Dalacin, Dalcop):** < 7 days and weight < 2000 g 10 mg/kg/day in 3 divided doses, < 7 days and weight > 2000 g 15 mg/kg/day in 3 divided doses, children 20 to 45 mg/kg/day in 3 to 4 divided doses.
- Clobazam:** 0.1 mg/kg/day initial dose. Usual maintenance dose. 0.3 to 1 mg/kg/day 12 hrly.
- Clonazepam (Rivotril, Clonopin):** 0.01 to 0.03 mg/kg/day to start with. Thereafter 0.3 mg/kg/day every 8 hours, after building up dose by increments of 0.25 mg every 3 days.
- Clonidine HCl (Catapres, Arkamin):** 5 to 10 mcg/kg/day.
- Cloxacillin (Klox):** 50 to 200 mg/kg/day (O or IM) in 4 divided doses.
- Coamoxiclav (Augmentin):** See amoxicillin with clavulanic acid.
- Codeine phosphate/sulfate:** 1 to 1.5 mg/kg/day for suppression of cough; 3 mg/kg/day for sedation or as analgesic.
- Colistin (Walamycin):** 5 to 8 mg/kg/day (O) in divided doses.
- Cortisone acetate (Cortin):** 2.5 to 10 mg/kg/day (O) in 3 divided doses. IM and IV dose is 1/2 of this.
- Cotrimoxazole (Septran, Oripim, Bactrim, Supristal, Synstat):** 4 to 10 mg/kg/day in terms of trimethoprim (O, IV) in 2 divided doses.
- Cromoglycate sodium (Cromal 5, Ifiral):** 20 mg every 6 hours by inhalation.
- Cyanocobalamin:** 30 to 50 µg/day to a total dose of 1000 to 5000 µg and then 100 µg every month in pernicious anemia.
- Cyclizine:** 6 to 12 years 25 mg/dose (O) up to 3 times/day as needed.
- Cyclophosphamide (Endoxan):** 2 to 3 mg/kg/day (O or IV) in divided doses or total of 7 days dose once in a week. For resistant neoplasm, use 4 to 8 mg/kg/day.
- Cycloserine:** 15 to 25 mg/kg/day (O) in 3 to 4 divided doses.
- Cyproheptadine (Peritol, Ciplactin):** 0.25 mg/kg/day (O) in 3 to 4 divided doses.
- Dantrolene:** Initially 0.5 mg/kg/dose twice a day. Build up dose in increments until desired result is obtained.
- Daunorubicin:** 0.5 to 1 mg/kg at one day or more intervals; 2 mg/kg at 4 days or more intervals; 2.5 to 3 mg/kg at 7 to 14 days intervals.
- Deferiprone (Oral chelating agent):** 100 mg/kg/day (O).
- Desferrioxamine (Desferal):** 30 to 70 mg/kg (SC infusion, administered by a special pump) over 5 to 8 hours 6 times a week. For high dose IV therapy, 6 to 12 g/day.
- Desmopressin acetate (DDAVP):** 5 to 30 mcg/day in 1 or 2 divided doses as nasal insufflation.
- Dexamethasone:** 0.25 to 0.6 mg/kg/day in 3 divided doses.
- Dextromethorphan:** 1 mg/kg/day in 2 to 3 divided doses.
- Dextropropoxyphene:** 2 to 4 mg/kg/day in divided doses.
- Diazepam (Calmose, Valium):** 0.1 to 0.5 mg/kg/dose (IM, IV) or 1 mg/year of age to a maximum 10 mg; 0.1 to 0.8 mg/kg/day (O) in 3 to 4 divided doses.
- Diazoxide (Hyperstat):** 5 mg/kg (IV) single dose.
- Dichlorophen (Anthiphen):** 2 to 4 g daily for 2 days.
- Dicyclomine (Colimex):** 5 mg/dose in infants > 6 months, 10 mg/dose in children, 40 mg/dose in adolescents.
- Diethyl carbamazine (Hetrazan):** 15 mg/kg/day (O) as single daily dose for 4 days in ascariasis; 10 to 12 mg/kg/day (O) in divided doses for 5 days, or 6 mg/kg/day (O) in divided doses for 5 days in filariasis and tropical eosinophilia.
- Digoxin:** See chapter 16.
- Diiodohydroxyquin (Diodoquin):** 40 mg/kg/day (O) in 2 to 3 divided doses.
- Diloxanide furoate (Furamide):** 20 mg/kg/day (O) for 10 days.
- Diltiazem:** 1.5 to 2 mg/kg/day (O) in 3 to 4 divided doses.
- Diphenoxylate hydrochloride (Lomotil):** 0.3 mg/kg/day (O) in divided doses.
- Diphenylhydramine (Benadryl):** 4 to 6 mg/kg/day (O) in 3 to 4 divided doses. For its use as antidote in phenothiazine toxicity. See Chapter 32.
- Diphenylhydantoin sodium (Dilantin):** 3 to 8 mg/kg/day (O) as single dose or in 2 divided doses; 10 to 15 mg/kg (IV,IM).
- Domperidone (Gastractiv, Domperon):** 0.2 to 0.4 mg/kg at 4 to 8 hour intervals.
- Dopamine HCl:** Start with 0.002 to 0.005 mg/kg/minute. If needed, increase by increments of 0.005 mg/kg/minute up to 0.05 mg/kg/minute.

- Doxorubicin (Adriamycin):** 1.2 to 2.4 mg/kg/dose (IV) every 3 weeks.
- Doxycycline:** 5 mg/kg/day (O) in 2 divided doses in first day. Then 2.5 mg/kg/day as a single daily dose.
- Enalapril:** 0.1 to 0.5 mg/kg/day (O) in 1 to 2 divided doses. 5 to 10 µg/kg/day (IV) in 1 to 2 divided doses.
- Ephedrine sulfate:** 3 mg/kg/day (O) in 4 to 6 divided doses.
- Epinephrine:** See adrenaline.
- Ergocalciferol:** 75 to 125 µg/day in rickets.
- Erythromycin (Erythrocin, E-mycin):** 40 to 50 mg/kg/day (O). The dose for newborn is 25 to 40 mg/kg/day (O).
- Ethacrynic acid:** 25 mg/dose (O); 0.5 to 1.0 mg/kg/dose (IV).
- Ethambutol:** 15 to 25 mg/kg/day (O) in a single dose.
- Ethionamide:** 10 to 20 mg/kg/day, with a maximum of 750 mg, in divided doses.
- Ethosuccimide (Zarontin):** <6 years—250 mg/day (O); > 6 years—500 mg/day (O), in 2 divided doses; or 15 to 25 mg/kg/day (O).
- Ferrous sulfate (Fersolate):** 1 mg/kg/day (O) for prophylaxis; 6 mg/kg/day (O) for therapeutic use (elemental iron).
- Fluticasone:** Rota disk dose 50 to 1000 µg twice depending upon asthma severity and need for systemic corticosteroids.
- Folic acid:** 5 to 20 mg/day (O), 1 mg/day (IM).
- Frusemide (Laxis):** 1 to 3 mg/kg/dose (O), 0.5 to 1.5 mg/kg/dose (IM).
- Furazolidin (Furoxone):** 8 mg/kg/day in 3 to 4 doses.
- Gentamicin (Garamycin):** 3 to 5 mg/kg/day (IM or IV) in first week of life, later up to 7.5 mg/kg/day in divided doses.
- Griseofulvin:** 10 to 20 mg/kg/day as a single dose in divided doses.
- Growth hormone:** 0.5-1 unit/kg once a week (SCIM). Alternatively, 0.07-0.14 unit/kg OD.
- Guanethidine sulfate (Ismelin):** 0.2 mg/kg/day (O) in 1 or 2 divided doses.
- Haloperidol (Serenace):** 0.05 mg/kg/day (O).
- Heparin:** 50 units/kg followed by 100 units/kg to be added to IV drip.
- Hydralazine (Apresoline):** 0.75 mg/kg/day (O) in 4 to 6 divided doses.
- Hydrochlorothiazide (Esidex):** 1/10th of chlorothiazide dose.
- Hydrocortisone:** In shock 50 mg/kg/dose IV every 4 hrly. Anti-inflammatory dose 1 to 5 mg/kg/day in 1 to 2 divided doses (IV, IM) and 2.5 to 10 mg/kg/day divided every 6 to 8 hrly (O)
- Ibuprofen (Brufen):** 20 mg/kg/day in 3 divided doses.
- Imipramine (Depsonil):** 1.5 mg/kg/day (O) in 3 to 4 divided doses. INH: 5 to 20 mg/kg/day (O) with a maximum of 300 mg/day.
- Indomethacin (Indocap, Ceplacid, Idicid):** 1 to 3 mg/kg/day (O) in 3 to 4 divided doses for anti-inflammatory/analgesic effect. For closure of PDA <48 hour - 0.2 mg/kg for 1 dose, then 2 doses of 0.1 mg/kg; 2 to 7 days - 3 doses of 0.2 mg/kg; > 7 days - 0.2 mg/kg once, then 2 doses of 0.25 mg/kg (IV).
- Insulin:** 0.1 unit/kg/hour (IV infusion) of soluble; 0.5 unit/kg/day in 3 divided doses.
- Iron-Dextran (Imferon):** See Chapter 22.
- Iron sorbitol (Jectofer):** 1.5 mg, (0.33 ml) kg/dose (IM).
- Isoniazid:** See INH.
- Isoproterenol hydrochloride:** 2 to 10 mg/dose sublingually thrice daily.
- Kanamycin (Kancin):** 10 to 15 mg/kg/day (IM).
- Ketotifen:** 0.25 to 0.5 mg (O) BD.
- Lactulose (Livo Luk):** Infants 2.5 to 10 ml/day in 3 to 4 divided doses, children 40 to 90 ml/day in 3 to 4 divided doses (O, PR)
- L-Asparaginase (Leunase):** 50 to 200 units/kg/day (IV infusion).
- Levamisole (Dewormis):** 2.5 to 5 mg/kg as a single dose.
- Levothyroxine:** See "thyroxine".
- Lincomycin HCl (Lincocin):** 30 mg/kg/day (O), 10 mg/kg/day (IM) 10 to 20 mg/kg/day (IV) in 2 to 3 divided doses.
- Loperamide (Lopamide, Imodium, Peloperin):** 0.3 mg/kg/day (O) or 0.1 mg/kg/dose (O).
- Loratadine (Loridin):** 5 mg/day for weight upto 30 kg 10 mg/day for weight > 30 kg.
- Lorazepam (Lorpose):** Sedation 0.05 mg/kg/dose (O), status epilepticus 0.05 mg/kg/dose (IV, IM), to be repeated after 15 to 20 minutes if indicated.
- Magnesium hydroxide (Milk of magnesia):** 0.5 mg/kg/day (O).
- Magnesium sulfate:** 0.1 to 0.4 mg/kg/dose (IM) as anticonvulsant.
- Mannitol:** For cerebral edema 2 g (10 ml)/kg as 20% solution given in 2 to 6 hours (IV). For oliguria/anuria 0.2 g i.e. 1 ml/kg (IV) single dose given in 3 to 5 minutes.

- Mebendazole (Wormin, Mebex, Pentelamin):** 100 mg twice daily for 3 days (O). For tapeworms (*T. saginata*, *T. solium*), the dose is double, i.e. 200 mg. On the contrary, a single dose of 100 mg, given only once, suffices in case of pinworm infestation.
- Mefanemic acid (Meftal):** 6.5 mg/kg/dose (O) or 20 to 30 mg/kg/day in divided doses.
- Mepacrine:** 5 mg/kg/day (O) in 3 divided doses for 5 to 7 days for giardiasis; 15 mg/kg with a maximum of 800 mg as a single dose for tapeworms.
- Mercaptopurine (6-MP, Purinethol):** 2.5 mg/kg/day (O).
- Metakelfin:** See Sulfamethopyrazine.
- Methandienone (Dianabol):** 0.04 mg/kg/day (O).
- Methenamine mandelate (Mandelamine):** 50 to 100 mg/kg/day (O) in 3 divided doses.
- Methicillin (Staphcillin):** Newborn—100 mg/kg/day (IM or IV). Others—100 to 400 mg/kg/day (IM or IV) in 4 to 6 divided doses.
- Methotrexate:** 0.12 mg/day (O); 0.25 to 0.5 mg/kg/day (IT), 3 to 5 mg/kg (IV) as single dose every other week.
- Methyl dopa (Aldomet):** 10 mg/kg/day (O) in 4 divided doses, increasing at 2 days or more intervals to as high as 65 mg/kg/day if needed.
- Methylprednisolone:** 0.4-1.7 mg/kg/day (IM, IV). Pulses; 30 mg/kg/day for 3-5 days. Shock and other emergencies; 30 mg/kg/dose over 10-20 minutes; may need repeat doses 4-6 hrly.
- Metoclopramide (Perinorm, Maxeron Reglan):** 0.5 mg/kg/day (O, IM, IV) in 3 divided doses.
- Metoprolol:** 1 to 5 mg/kg/day in 2 to 3 divided doses.
- Metronidazole (Flagyl, Metrogyl):** 10 to 20 mg/kg/day (O) for 5 to 7 days in divided doses for giardiasis; 20 to 50 mg/kg/day (O) for 10 days in divided doses for amebiasis. IV dose is 21 mg/kg/day.
- Midazolam:** 0.15 mg/kg (IV) followed by continuous infusion of 1 to 2 µg/kg/min in status epilepticus.
- Milk of magnesia:** See magnesium hydroxide.
- Minoxidil:** 0.2 mg/kg/day (O) as a single dose. Follow by stepwise increase to 0.25 to 1 mg/kg/day.
- Mitomycin C:** 0.05 mg/kg/day (IV) for 5 days.
- Morphine:** 0.1 to 0.2 mg/kg/dose (SC).
- Moxiactum (Moxam):** Under 7 days - 100 mg/kg/day in 2 divided doses. Above 7 days - 150 mg/kg/day in 3 divided doses.
- Mupirocin (Bactroban, T-Bact):** The ointment is required to be topically applied to the affected skin area (Gram-positive infections, including methicillin-resistant and beta-lactamase producing strains of staphylococcus) thrice daily.
- Mustine HCl:** 0.1 to 0.4 mg/kg/dose (IV) with a maximum 8 mg for 3 to 4 days.
- Nalidixic acid (NegGram, Gramoneg):** 50 mg/kg/day (O) in 4 divided doses.
- Naloxone:** 0.1 mg/kg/dose (IV) to max dose 2 mg.
- Naproxen (Naxid, Artagen):** 10 mg/kg/day (O) in 2 divided doses.
- Neostigmine:** Myasthenia gravis 0.01 to 0.04 mg/kg/dose (IM, IV, SC) in 5 to 10 minutes every 2 to 4 hours.
- Netilmicin sulfate (Netromycin):** 2.5 to 3.0 mg/kg/dose (IM, IV).
- Neomycin:** 50 to 100 mg/kg/day (O) in 3 to 4 doses.
- Niclosamide (Yomesan, Niclosan):** 40 mg/kg (O) with a maximum of 2 g; for 7 days in *H. nana* and a single dose in *T. solium* and *T. saginata*.
- Nifedipine (Calcigard):** 0.2 to 0.7 mg/dose (SL).
- Nikethamide (Coramine):** 0.1 mg/kg/dose (IV, IM).
- Nimesulide (Nimulid, Nise):** 5 mg/kg/day (O) in 2 or 3 divided doses.
- Nitrazepam (Nitravet):** 0.12 to 0.2 mg/kg/day in single or 2 divided doses.
- Nitrofurantoin (Furadantin):** 5 to 10 mg/kg/day (O) in divided doses.
- Nitrogen mustard (Mustragen):** 0.4 mg/kg (IV) as single dose or in 2 divided doses at intervals of 1 to 2 weeks.
- Nondrone (Durabolin):** Infants: 5 mg once a week or 10 mg once a fortnight (IM); children: 10 to 12.5 mg once every 10 days.
- Norepinephrine:** 0.05 to 0.1 µg/kg/min to max dose 2 µg/kg/min.
- Norfloxacin (Norflox):** 4 to 12 mg/kg/day for 5 days for GI infection; 7 to 21 days for UTI, in single or 2 doses. A single high dose treatment for gonorrhoea suffices.
- Nystatin (Mycostatin):** Newborn: 4 lakh units/day in divided doses (local application); children: 1 to 2 million units/day in divided doses.
- Ofloxacin (Tarvid):** 4 to 16 mg/kg/day as a single dose or in 2 divided doses.
- Omeprazole (Odd):** 20 mg OD before breakfast (only for grown-ups)
- Orciprenaline (Alupent):** 0.02 mg/kg/dose (IM), 2 to 3 mg/kg/day (O) in 4 divided doses.
- Oxacillin (Prostaphilin):** 50 to 200 mg/kg/day in divided doses.

Oxymetholone (Adroyd): 0.1 to 0.8 mg/kg/day (O).

Pancreatin (Pancreatic enzymes): 300 to 600 mg with each main meal.

Paracetamol (Calpol, Crocin, Metacin): See acetaminophen.

Paraldehyde: 0.15 ml/kg/dose (O, IM, IV): 0.3 to 0.6 ml/kg/dose (rectal).

Paromomycin (Humatin): 25 to 50 mg/kg/day in 3 divided doses for 5 to 10 days.

PAS: 200 to 400 mg/kg/day in divided doses.

Pemoline: 1 mg/kg/day orally, as single dose each morning to max dose 3 mg/kg/day.

Penicillamine: Wilson disease 20 mg/kg/day in 2 to 4 divided doses (O), lead poisoning 25 to 40 mg/kg/day in 3 to 4 divided doses, cystinuria 30 mg/kg/day in 4 divided doses, rheumatoid arthritis 3 mg/kg/day (maximum 250 mg/day total dose) in 2 divided doses for 3 months with dose increase to 6 mg/kg/day (maximum 600 mg/day) according to tolerance. In adolescents, dose is 125 to 250 mg/day increased to 1 to 1.5 g/day.

Penicillin

Oral (Pentids): 50 thousand units/kg/day in 3 to 4 divided doses.

Procaine: < 4 years—2 lakh units (IM) once or twice daily, >4 yr—4 lakh units (IM) once or twice daily.

Crytalline: 50 thousand to 4 lakh units/kg/day (IM or IV) in divided doses.

Long acting: see Chapter 22.

Pethidine: 1 to 2 mg/kg/dose (IM).

Pheniramine maleate: 1 to 5 mg/kg/day (O, IM).

Phenobarbital (Luminal): 3 to 5 mg/kg/dose (IM) for acute attack of convulsions, 3 to 5 mg/kg/day (O) for maintenance therapy and sedation.

Phenytoin: See “diphenylhydantoin sodium”.

Piperazine: 100 to 150 mg/kg (O) as a single administration for ascariasis; 50 to 75 mg/kg/day for 7 successive days for pinworm infestation.

Piracetam (Neurocetam): 40 mg/kg in divided doses (O).

Piroxicam: 0.2 to 0.3 mg/kg/day (O) to max dose 15 mg/kg/day.

Potassium chloride: 1 to 3 mEq/kg (IV) for hypokalemia; 3 to 5 mEq/kg/day (O) for advanced PEM.

Praziquantel (PZQ): 50 mg/kg/day (O) in 3 divided doses for 14 days for neurocysticercosis; 50 mg/kg (O) single dose once daily for tapeworms and liver fluke.

Pralidoxime: 20 to 50 mg/kg/dose (IM, IV). Repeat if needed after one hour.

Prednisolone (Wysolone): Generally 1 to 2 mg/kg/day in divided doses (O).

Primaquine: 0.3 mg (base)/kg/day (O) for 14 days. Also see Chapter 14.

Primidone (Mysoline): 125 mg for under 8 years and 250 mg after 8 years, twice or thrice daily; 40 to 50 mg/kg/day in 2 to 3 divided doses.

Probenecid (Procid, Benamid): 250 mg twice daily for one week followed by 500 mg twice daily.

Prochlorperazine (Stemetil): 0.5 mg/kg/day (O) in divided doses.

Promethazine (Phenergan): 0.5 mg/kg/dose (O, IM).

Propranolol (Ciplar Inderal): 0.15 to 0.25 mg/kg/dose (IV) for cyanotic spells; 0.5 to 1 mg/kg/day (O) in divided doses for arrhythmias. For hypertension, dose is far higher.

Pseudoephedrine hydrochloride (Sudafed): 3 to 5 mg/kg/day in 4 divided doses.

Pyrantel (Nemocid, Antiminth): 10 mg/kg (O) as a single dose.

Pyribenzamine: 5 mg/kg/day (O) in 4 to 6 divided doses.

Pyridoxine: 50 to 100 mg/day (O, IM, IV) for pyridoxine dependence.

Pyrazinamide: 15 to 40 mg/kg/day to max dose 2 g/day.

Pyrvinium (Vanquin): 5 mg/kg/day (O).

Quinine: 25 mg/kg/day in 3 divided doses (O) for 10 to 14 days; 10 mg/kg/dose (IV) by slow infusion over 1 to 2 hours, to be repeated at intervals of 12 hours till clinical response occurs.

Ranitidin (Ranitid): 1 to 4 mg/kg/day (O, IM, IV) in 2 to 3 divided doses.

Reserpine (Serpasil): 0.07 mg/kg/dose (IM) every 8 to 24 hours for acute hypertension as in acute nephritis; 0.02 mg/kg/day (O) in 3 to 4 divided doses for chronic hypertension.

Ribavirin (Tribavirin): Continuous aerosolization for 12 to 18 hours daily for 3 to 7 days.

Rifampicin (Rifamycin): 10 to 20 mg/kg/day (O) in single daily dose.

Roxithromycin (Rulide, Ralrox, Roxid, Rokcid, Zerox): 5 mg/kg/day in 2 divided doses.

Salbutamol (Salbetol, Brethmol): 0.2 to 0.4 mg/kg/day.

Salmeterol: 1 to 2 puffs (21 µg) aerosol 12 hrly. Titrate to desired effect.

- Secnidazole (Secnil):** 30 mg/kg with a maximum of 2 g as a single dose once only.
- Sisomicin sulfate (Ensamycin):** Under 2 weeks: 5 mg/kg/day in 3 divided doses; 4 weeks: 6 mg/kg/day in 3 divided doses; 4 weeks to 1 year: 4.5 to 6 mg/kg/day in 3 divided doses; above 1 year: 3 to 4.5 mg/kg/day in 3 divided doses.
- Sodium bicarbonate:** Roughly 1-2 mEq/kg/dose. Also see Chapter 16 (Fluids, Electrolytes and Acid-base Balance and its Disturbances).
- Sodium valproate:** 20 to 30 mg/kg (under 20 kg), 50 mg/kg (over 20 kg) in 2 to 3 divided doses. Start with relatively smaller dose (say 10 mg/kg/day) and increase by increments of 5 to 10 mg at 3 to 7 days intervals to the maximum dose.
- Spiranolactone (Aldactone):** 1.5 to 3 mg/kg/day (O).
- Streptomycin Sulfate:** 20 to 50 mg/kg/day (IM), 1 to 2 mg/kg/day (IT), 100 mg/kg/day (O) in divided doses.
- Sulfadiazine:** 100 to 150 mg/kg/day (O); 100 mg/kg/day (IV) in 4 divided doses.
- Sulfadimethoxine (Madribon):** 0.025 g/kg/day (O).
- Sulfadimidine:** See Sulfadiazine.
- Salfaguanidine:** 150 mg/kg/day (O) in 4 to 6 divided doses.
- Sulfamethopyrazine or SMP (Metakelifin when combined with pyrimethamine):** 25 mg/kg as a single dose.
- Sulfasalazine:** 40 to 75 mg/kg/day in 3 to 4 divided doses, not to exceed 6 g/day. Maintenance dose 30 to 50 mg/kg/day in 3 to 4 divided doses.
- Sulfisoxazole (Gantrisin):** 75 to 150 mg/kg/day (O), 50 to 100 mg/kg/day (IV) in 4 to 6 divided doses.
- Surfactant:** 4 ml/kg/dose (IT); 4 aliquots are administered intratracheally in varying positions.
- Terbutaline sulfate (Brikanyl, Bronkine):** 0.2 mg/kg/day (O), 0.005 mg/kg/dose (SC); IV infusion may be given in difficult cases of bronchial asthma.
- Terfanidine (Terfid):** 2 to 4 mg/kg/day in 2 divided doses. 3 to 6 years 30 mg/day in 2 divided doses, 6 to 12 years 60 mg/kg/day in 2 divided doses, adolescents 120 mg/day in 2 divided doses.
- Tetanus immunoglobulin:** Treatment of tetanus in children. 500 to 3000 units (IM/IV).
- Tetrachlorethylene:** 0.1 ml/kg (O) with a maximum of 3 to 4 ml as a single dose to be given after overnight fast.
- Tetracyclines:** Oxytetracycline (Terramycin), tetracycline hydrochloride (Achromycin) and Chlortetracycline (Aureomycin)—25 to 50 mg/kg/day (O) in 4 divided doses; 10 to 25 mg/kg/day (IM) and 10 to 15 mg/kg/day (IV) in 2 divided doses.
Demethylchlortetracycline (Ledermycin)—10 mg/kg/day in 3 to 4 divided doses.
Rolitetracycline (Reverin): 15 to 20 mg/kg/day (IM, IV) in single or two divided dose.
- Theophylline:** See aminophylline.
- Thiabendazole (Mintezol):** 50 mg/kg/day (O) in 2 divided doses.
- Thiacetazone:** 3 to 5 mg/kg/day (O).
- Thyroid (Desiccated):** Infants 15 mg/day (O), children 30 mg/day (O). Increase by increments of 15 mg every 1 to 3 weeks to 60 to 180 mg single daily dose.
- Thyroxine (Eltroxin):** Start with 50 to 100 mcg. Increase every 3 to 4 week by increments of 25 to 50 mcg to about 200 to 300 mcg.
- Ticarcillin disodium (Ticar):** 75 mg/kg/dose (IV, IM).
- Tinidazole (Tridazole, Tiniba, Probit):** 60 mg/kg/day for 3 days for intestinal amebiasis; 50 mg/kg as a single dose once only for giardiasis.
- Tobramycin sulfate (Nobcin):** Under 7 days - 4 mg/kg/day in 2 doses. Above 7 days - 6 mg/kg/day in 3 doses.
- Trimeprazine tartrate (Vallergan):** 2.5 to 5 mg 3 to 4 times daily for urticaria and pruritus; 2 to 4 mg/kg (O) or 0.6 to 0.9 mg/kg (IM) 1 to 2 hours before surgery as preanesthetic medication.
- Trimethadione (Tridione):** 15 to 50 mg/kg/day in 2 to 3 divided doses.
- Trimethoprim with sulfamethoxazole (Septran, Bactrim):** 4 to 10 mg/kg/day (O) with reference to trimethoprim.
- Valproic Acid:** See sodium valproate.
- Vancomycin HCL (Vancocin):** Children 45 to 60 mg/kg/day (IV infusion) in 2-3 divided doses; adolescents 0.5 g/6 hourly or 1 g every 12 hourly; neonates 15- 45 mg/kg/day in divided doses, the lower dose being for LBW < 1200 g or < 7 days.
- Vasopressin (Pitressin):** Diabetes insipidus; 5-20 units (SC, IM) every 4 hourly. Esophageal variceal bleed; 20 units (IV) over 15 minutes.
- Versenate (EDTA):** 12.5 mg/kg (IM).
- Vinblastine:** 0.1 to 0.2 mg/kg/week (IV).
- Vincristine:** 0.05 to 0.15 mg/kg/week (IV).

Vitamin C: See ascorbic acid.

Vitamin D (Arachitol, Calcirol): A massive dose of 3 (< 1 year) or 6 lakh (> 1 year) units (IM), to be repeated after 3-4 weeks if indicated, or 60,000 units (O) /day for 10 days.

Xantinol nicotinate (Complamina, Xanthomina): 150 to 600 mg twice daily after meals. Inj 300 to 900 mg (IM, IV infusion).

Xylocaine HCl: 1 ml/kg/dose (IV).

Xylometazoline HCl (Otrivin): 1 to 2 drops of 0.05% solution into each nostril once or twice daily.

Zinc (Zincolak, Zinfate): 0.3 mg/kg/day (O) in divided doses.

Zidovudine (Retrovir, Zidovir): 12 to 22 mg/kg/day in 4 divided doses (IV) or 12 mg/kg/day in 4 divided doses (IV) or continuous IV infusion.

Zinc (Zevit, Zincolak): Infants 0.5 mg/kg/day, children 1 mg/kg/day, adolescents 1 mg/kg/day.

Appendices

Appendices

APPENDIX A

USEFUL NORMAL LABORATORY VALUES

BLOOD

Bleeding time (BT) 1 to 3 minutes
Clotting (coagulation) time (CT) 3 to 10 minutes
Erythrocyte sedimentation rate (ESR) 15 mm in first hour
Hemoglobin Birth: 16 to 18 g/dl, 2 weeks: 15 to 16 g/dl, 6 months and after: 12 g/dl later childhood and adults: 14 to 16 g/dl.
Reticulocyte count Birth-3 to 7% Later: 1 to 2% or below
Eosinophil count 2 or 3%
Platelet count Above, 2,00,000/cmm
Prothrombin time 10 to 15 seconds
Vitamin B₁₂ Above 200 micromicro g/dl
Bilirubin Birth and neonatal period: 1 mg% or slightly more
Later: 0.2 to 0.8 mg%
Conjugated bilirubin: 0 to 0.3 mg%
Cholesterol Newborn: 50 to 100 mg%, Infant: 70 to 125 mg%,
1 to 5 years: 100 to 200 mg%, Later: 150 to 250 mg%
Glucose 60 to 100 mg%
Alkaline phosphatase 3 to 13 Bodansky units, 10 to 20 King-Armstrong units
Acid phosphatase 1 to 5 King-Armstrong units
Serum glutamic oxaloacetic transaminase (SGOT) 4 to 40 units
Serum glutamic pyruvate transaminase (SGPT) 5 to 45 units
Iron 0.04 to 0.18 mg%
Iron binding capacity 0.187 to 0.65 mg%
Proteins *Total*—Newborn: 4.5 to 7.7, 1 year: 5.6 to 7.3, *Later* 6.4 to 7.5 g/dl
Albumin—Newborn: 2.5 to 5.0, 1 year: 3.5 to 5.0, *Later* 3.7 to 5.0 g/dl.

URINE

Pus cells Newborn: 0 to 5, Infant: 2 to 4, *Later*: 2 to 4 or less/high power field on a centrifuged sample.
Red cells Newborn: 0 to 1, *Later*: nil/high power field on a centrifuged sample.
Proteins Newborn: traces, *Later*: nil
Casts Nil

CEREBROSPINAL FLUID (CSF)

Pressure 70 to 200 mm of water
Glucose 50 to 75 mg% (usually 20 mg% less than blood glucose level); between 6 months to 10 years, CSF sugar may normally be 70 to 90 mg%
Proteins 20 to 50 mg% (80% is the albumin component); ventricular and cisternal fluids contain far less proteins than in lumbar fluid.
Chlorides 110 to 130 mEq/L (higher range is for grown-up children).
Cell count Below 1 year: 0 to 10, 1 to 4 years: 0 to 8, 5 years and later: 0 to 5 cells/cmm.

APPENDIX B

IMPORTANT CONVERSIONS

Milliequivalents

Milliequivalents (mEq) per liter
$$= \frac{\text{Milligrams percent} \times 10}{\text{Atomic weight}} \times \text{Valency}$$

With this formula, the number of reacting particles in a liter of solution can be determined by dividing the atomic weight of each ion into the total quantity (in milligrams) of that particular ion in one liter of solution. The resulting figure multiplied by the valency of the ion of this basis.

Data for Conversion of Milligrams per 100 ml to Milliequivalents per Liter of Plasma

$$\text{Sodium (Na)} = \frac{\text{mg per } 100 \text{ ml} \times 10}{23 \text{ (atomic weight)}} \times 1 \text{ (valency)} = \text{mEq per liter}$$

$$\text{Potassium (K)} = \frac{\text{mg per } 100 \text{ ml} \times 10}{39} \times 1 \text{ (valency)} = \text{mEq per liter}$$

$$\text{Calcium (Ca)} = \frac{\text{mg per } 100 \text{ ml} \times 10}{40} \times 2 \text{ (valency)} = \text{mEq per liter}$$

$$\text{Chloride (Cl)} = \frac{\text{mg per } 100 \text{ ml} \times 10}{35.5} \times 1 \text{ (valency)} = \text{mEq per liter}$$

Factors for Rapid Conversion of Milligrams per 100 ml to Milliequivalents per Liter

Cations	Factors	Anions	Factors
Sodium (Na)	0.435	Bicarbonate (HCO ₃)	0.455
Potassium (K)	0.257	Chloride (Cl)	0.286
Calcium (Ca)	0.5	Chloride (as NaCl)	0.150
Magnesium (Mg)	0.833	Phosphate (HPO ₄)	0.58
		Sulphate (SO ₄)	0.625

Temperature

Conversion of °C to °F = (9/3X°C) + 32 = °F

Conversion of °F to °C = 5/9 (°F-32) = °C

Inches to Centimeter

1 inch = 2.54 cm
1 cm = 0.39 inch

Minim to Millilit (ml)

1 minim = 0.06 ml
1 ml = 15 minims

Equivalent Imperial and Metric Quantities

1 grain = 65 milligrams
1 ounce = 28 grams
1 pound = 453 g
2.2 pounds = 1 kg

Centigrade to fahrenheit temperature reading

°C	°F	°C	°F	°C	°F	°C	°F
0	= 32	35.5	= 95.9	40	= 104	60	= 140
5	= 41	36	= 96.8	40.5	= 104.9	65	= 149
10	= 50	36.5	= 97.7	41	= 105.8	70	= 158
15	= 59	37	= 98.6	41.5	= 106.7	75	= 167
20	= 68	37.5	= 99.5	42	= 107.6	80	= 176
25	= 77	38	= 100.4	43	= 109.4	85	= 185
30	= 86	38.5	= 101.3	45	= 113	90	= 194
32	= 89.6	39	= 102.2	50	= 122	95	= 203
35	= 95	39.5	= 103.2	55	= 131	100	= 212

Pounds to Kilograms
1 kg = 2.2 lb; 1 lb = 0.4536 kg

lb	kg	lb	kg	lb	kg	lb	kg
5	2.3	60	27.2	115	52.2	170	77.1
10	4.5	65	29.5	120	54.4	175	79.4
15	6.8	70	31.7	125	56.7	180	81.6
20	9.1	75	34.0	130	58.9	185	83.9
25	11.3	80	36.3	135	61.2	190	86.2
30	13.6	85	38.6	140	63.5	195	88.5
35	15.9	90	40.8	145	65.8	200	90.7
40	18.1	95	43.1	150	68.0	205	93.0
45	20.4	100	45.4	155	70.3	210	95.3
50	22.7	105	47.6	160	72.6	215	97.5
55	25.0	110	49.9	165	74.8	220	99.8

Feet and inches to centimeters

ft	in	cm	ft	in	cm	ft	in	cm	ft	in	cm
0	6	15.2	2	7	78.7	10	116.8	5	1	159.4	
1	0	30.5	5	8	81.2	11	119.3	5	2	157.5	
1	6	45.7	2	9	83.8	0	121.9	5	3	160.0	
1	7	48.3	2	10	86.3	1	124.4	5	4	162.6	
1	8	50.8	2	11	88.8	2	127.0	5	5	165.1	
1	9	53.3	3	0	91.4	4	3	129.5	5	6	167.6
1	10	55.9	3	1	93.9	4	4	132.0	5	7	170.2
1	11	58.9	3	1	96.4	4	5	134.6	5	8	172.7
2	0	61.0	3	3	99.0	4	6	137.1	5	9	175.3
2	1	63.5	3	4	101.6	4	7	139.6	5	10	177.8
2	2	66.0	3	5	104.1	4	8	142.2	5	11	180.3
2	3	68.6	3	6	106.6	4	9	144.7	6	0	182.9
2	4	71.1	3	7	109.2	4	10	147.3	6	1	185.4
2	5	73.6	3	8	111.7	4	11	149.8	6	2	188.0
2	6	76.1	3	9	114.2	5	0	152.4	6	3	190.5

SI Unit Conversion

The SI system (System International d' Units) is an international system of units now generally employed in the basic sciences, and it has now been adopted in clinical biochemistry in the United Kingdom and many other countries. It has replaced the somewhat empirical range of units (e.g. mg/100 ml, mEq/l) with which clinicians have long been familiar but which has often varied from one laboratory to another. While international standardization is obviously desirable, the change to the SI unitage will involve clinicians in the task of assimilating quite a new range of normal values with the obvious dangers of misinterpretation of laboratory reports while they adjust to a new and unfamiliar system. In order to avoid such confusion, the following short account of SI unit conversion may be in order.

The new unit for chemical measurement of quantity, where the molecular weight (MW) of the substance being measured is known and expressed in grams, is the mole.

Number of moles (mol) =

The commoner decimal fractions will be millimoles (mmol:10⁻³), micromoles (μmol:10⁻⁶), nanomoles (nmol:10⁻⁹) and picomoles (pmol:10⁻¹²). Although the SI unit of volume is the cubic metre (m³), the liter is accepted as exactly equivalent to one cubic decimeter (dm³) and in clinical biochemistry is the unit of volume. The units of concentration will, therefore, be mmol/l, μmol/l and nmol/l. However, where the molecular weight of the substance being measured is unknown or uncertain the units will be in grams or milligrams per liter, e.g. a total serum protein of 70 g/100 ml becomes 60 g/l.

Example

Results Previously Expressed as mEq/L

$$\begin{aligned} \text{Number of equivalents} &= \frac{\text{wt in g}}{\text{Equivalent wt}} \\ &= \frac{\text{wt in g} \times \text{valency}}{\text{MW}} \end{aligned}$$

In the case of univalent ions such as Na and K, and units will remain the same. A serum Na of 140 mEq/L becomes 140 mmol/l. For polyvalent ions the old units are divided by the valency. For instance, a serum Ca of 5 mEq/L becomes 2.5 mmol/l.

Conversion Factors for SI Units			
	MW	From SI Units	To SI Units
Amino acid nitrogen	14.01		
Plasma		$\text{mmol}/1 \times 1.40 = \text{mg}/\text{dl}$	$\text{mg}/\text{dl} \times 0.714 = \text{mmol}/1$
Urine		$\text{mmol}/24 \text{ hr} \times 14.01 = \text{mg}/24/\text{hr}$	$\text{mg}/24 \text{ hr} \times 0.0714 = \text{mmol}/24 \text{ hr}$
Ammonium	17.03	$\mu\text{mol}/1 \times 1.703 = \mu\text{dl}$	$\mu\text{g}/\text{dl} \times 0.587 = \mu\text{mol}/1$
Barbiturate	184.2	$\mu\text{mol}/1 \times 0.0184 = \text{mg}/\text{dl}$	$\text{mg}/\text{dl} \times 54.20 = \mu\text{mol}/1$
Bilirubin	584.7	$\mu\text{mol}/1 \times 0.015 = \text{mg}/\text{dl}$	$\text{mg}/\text{dl} \times 17.1 = \mu\text{mol}/1$
Calcium	40.08		
Plasma		$\text{mmol}/1 \times 4.008 = \text{ml}/\text{dl}$	$\text{mg}/\text{dl} \times 0.250 = \text{mmol}/1$
Urine		$\text{mmol}/24 \text{ hr} \times 40.08 = \text{mg}/24 \text{ hr}$	$\text{mg}/24 \text{ hr} \times 0.0250 = \text{mmol}/24 \text{ hr}$
Catecholamines (Urine)	183.2	$\mu\text{mol}/24 \text{ hr} \times 183 = \mu\text{g}/24 \text{ hr}$	$\mu\text{g}/24 \text{ hr} \times 0.00546 = \mu\text{mol}/24 \text{ hr}$
Cholesterol	386.7	$\text{mmol}/1 \times 31.7 = \text{mg}/\text{dl}$	$\text{mg}/\text{dl} \times 0.0359 = \text{mmol}/1$
Copper	63.54		
Plasma		$\mu\text{mol}/1 \times 6.35 = \mu\text{g}/\text{dl}$	$\mu\text{g}/\text{dl} \times 0.157 = \mu\text{mol}/1$
Urine		$\mu\text{mol}/24 \text{ hr} \times 63.5 = \mu\text{g}/24 \text{ hr}$	$\mu\text{g}/24 \text{ hr} \times 0.0157 = \mu\text{mol}/24 \text{ hr}$
Cortisol	362.5	$\text{nmol}/1 \times 0.0362 = \mu\text{g}/\text{dl}$	$\mu\text{g}/\text{dl} \times 27.6 = \text{nmol}/24 \text{ hr}$
Creatinine	113.1		
Plasma		$\mu\text{mol}/1 \times 0.0113 = \text{mg}/\text{dl}$	$\text{mg}/\text{dl} \times 88.4 = \mu\text{mol}/1$
Urine		$\text{mmol}/24 \text{ hr} \times 0.113 = \text{g}/24 \text{ hr}$	$\text{g}/24 \text{ hr} \times 88.4 = \text{mmol}/24 \text{ hr}$
Ethanol (Alcohol)	46.07	$\text{mmol}/1 \times 4.607 = \text{mg}/\text{dl}$	$\text{mg}/\text{dl} \times 0.0217 = \text{mmol}/1$
Fat (Fecal)	284.5	$\text{mmol}/24 \text{ hr} \times 0.284 = \text{g}/24 \text{ hr}$	$\text{g}/24 \text{ hr} \times 3.52 = \text{mmol}/24 \text{ hr}$
Fibrinogen	Uncertain	$\text{g}/1 \times 100 = \text{mg}/\text{dl}$	$\text{mg}/\text{dl} \times 0.01 = \text{g}/1$
Glucose	180.2		
Blood or Plasma		$\text{mmol}/1 \times 18.02 = \text{mg}/\text{dl}$	$\text{mg}/\text{dl} \times 0.0555 = \text{mmol}/1$
Urine		$\text{mmol}/1 \times 0.0180 = \text{mg}/\text{dl}$	$\text{g}/\text{dl} \times 55.5 = \text{mmol}/1$
CSF		as for blood or plasma	as for blood or plasma
HMMA or VMA (Urine)	198.2	$\mu\text{mol}/24 \text{ hr} \times 0.198 = \text{mg}/24 \text{ hr}$	$\text{mg}/24 \text{ hr} \times 5.05 = \mu\text{mol}/24 \text{ hr}$
Hydroxyproline (Urine)	131.1	$\text{mmol}/24 \text{ hr} \times 131.1 = \text{mg}/24 \text{ hr}$	$\text{mg}/24 \times 0.00763 = \text{mmol}/24 \text{ hr}$
Iron and TIBC	55.85	$\mu\text{mol}/1 \times 5.59 = \mu\text{g}/\text{dl}$	$\mu\text{g}/\text{dl} \times 0.179 = \mu\text{mol}/1$
Lead	207.2		
Blood		$\mu\text{mol}/\text{L} \times 20.7 = \mu\text{g}/\text{dl}$	$\mu\text{g}/\text{dl} \times 0.0483 = \mu\text{mol}/1$
Urine		$\mu\text{mol}/24 \text{ hr} \times 207 = \mu\text{g}/24 \text{ hr}$	$\mu\text{g}/24 \text{ hr} \times 0.00483 = \mu\text{mol}/24 \text{ hr}$
Magnesium	24.31		
Plasma		$\text{mmol}/1 \times 2.43 = \text{mg}/\text{dl}$	$\text{mg}/\text{dl} \times 0.411 = \text{mmol}/1$
Urine		$\text{mmol}/24 \text{ hr} \times 24.3 = \text{mg}/24 \text{ hr}$	$\text{mg}/24 \text{ hr} \times 0.0411 = \text{mmol}/29 \text{ hr}$
Estriol (Urine)	288.4	$\mu\text{mol}/24 \text{ hr} \times 0.228 = \text{mg}/24 \text{ hr}$	$\text{mg}/24 \text{ hr} \times 3.47 = \mu\text{mol}/24 \text{ hr}$
17-Oxosteroids (Urine)	288.4	$\mu\text{mol}/24 \times 0.288 = \text{mg}/24 \text{ hr}$	$\text{mg}/\text{hr} \times 3.47 = \mu\text{mol}/24 \text{ hr}$
Phenylalanine	165.2	$\mu\text{mol}/1 \times 0.0165 = \text{mg}/\text{dl}$	$\text{mg}/\text{dl} \times 60.5 = \mu\text{mol}/1$
Phosphate	30.97		
Serum		$\text{mmol}/1 \times 3.10 = \text{mg}/\text{dl}$	$\text{mg}/\text{dl} \times 0.323 = \text{mmol}/1$
Urine		$\text{mmol}/24 \text{ hr} \times 0.0310 = \text{g}/24 \text{ hr}$	$\text{g}/24 \text{ hr} \times 32.3 = \text{mmol}/24 \text{ hr}$
Preganediol (Urine)	320.5	$\text{mmol}/24 \text{ hr} \times 0.320 = \text{mg}/24 \text{ hr}$	$\text{mg}/24 \text{ hr} \times 3.12 = \mu\text{mol}/24 \text{ hr}$
Pregnanetriol (Urine)	336.5	$\text{mmol}/24 \text{ hr} \times 0.336 = \text{mg}/24 \text{ hr}$	$\text{mg}/24 \text{ hr} \times 2.97 = \mu\text{mol}/24 \text{ hr}$
Protein	Uncertain	$\text{g}/1 \times 0.1 = \text{g}/\text{dl}$	$\text{g}/\text{dl} \times 10 = \text{g}/1$
Serum albumin	Uncertain	$\text{g}/1 \times 0.1 = \text{g}/\text{dl}$	$\text{g}/\text{dl} \times 10 = \text{g}/1$
CSF Protein	Uncertain	$\text{g}/1 \times 100 = \text{mg}/\text{dl}$	$\text{mg}/\text{dl} \times 0.01 = \text{g}/1$
Protein-bound iodine	126.9	$\text{nmol}/1 \times 0.0127 = \mu\text{g}/\text{dl}$	$\text{mg}/\text{dl} \times 78.8 = \text{mmol}/1$
Salicylate	138.1	$\text{mmol}/1 \times 13.81 = \text{mg}/\text{dl}$	$\text{mg}/\text{dl} \times 0.0724 = 0.0724 = \text{mmol}/1$
Thyroxine	776.9	$\text{nmol}/1 \times 0.0777 = \mu\text{g}/\text{dl}$	$\text{ng}/\text{dl} \times 12.87 = \text{nmol}/1$
Triiodothyronine	651.01	$\text{nmol}/1 \times 0.651 = \text{ng}/\text{dl}$	$\text{ng}/\text{dl} \times 1.54 = \text{nmol}/1$
Triglyceride	885.4	$\text{mmol}/1 \times 88.5 = \text{mg}/\text{dl}$	$\text{mg}/\text{dl} \times 0.0113 = \text{mmol}/1$
Urate (uric acid)	168.1	$\text{mmol}/1 \times 16.81 = \text{mg}/\text{dl}$	$\text{mg}/\text{dl} \times 0.0596 = \text{mmol}/1$
Urea	60.06	$\text{mmol}/1 \times 6.01 = \text{mg}/\text{dl}$	$\text{mg}/\text{dl} \times 0.166 = \text{mmol}/1$
PO ₂	-	kPax 7.52 = mm Hg	mm Hg $\times 0.133 = \text{kPa}$
PCO ₂			
Units of Energy	-	Joules (kJ) $\times 0.238 = \text{calories}$	calories $\times 4.2 = \text{Joules (kJ)}$

Results Previously Expressed as mg/100 ml

The method of conversion to mmol/l is to divide by the molecular weight (to convert from mg to mmol) and to multiply by 10 (to convert from 100 ml to a liter). For example, the molecular weight of urea is 60 and of glucose 180 but concentrations of urea of 60 mg/100 ml and of glucose of 180 mg/100 ml both become 10 mmol/l.

The SI unit of pressure is the pascal (Pa) and in the range at present usually expressed as mm of mercury the appropriate unit is the kilo-pascal (kPa). This unit, however, may not be brought into clinical use for some time.

For some of the more important measurements a ready means of interconversion of the SI unit and the obsolescent unit in two forms, (i) conversion multiplication factors, (ii) nomograms is available. It should be noted that the expression "100 ml" should now be shown as "deciliter (dl)". Certain substances, such as enzyme activities, will continue to be expressed in units of various types and cannot be expressed in SI units.

APPENDIX C INTERNATIONAL DAYS

7th March	Measles Immunization Day
8th March	International Women's Day
15th March	World Handicapped Day
21st March	World Forest Day
7th April	World Health Day
18th April	World Heritage Day
22nd April	Earth Day
30th April	Child Labour Day
3rd May	World Asthma Day
15th May	International Family Day
31st May	World NoTobacco Day
5th June	World Environment Day
26th June	Anti Drug Abuse Day
1st July	Doctors Day
11th July	World Population Day
29th July	World ORS Day
1st-7th August	Breastfeeding Week
8th September	World Literacy Day
27th September	World Tourism Day
1st October	Blood Donation Day
3rd October	World Nature Day
4th October	World Animal Welfare Day
5th October	World Heart Day
8th October	World Senior Citizens Day
16th October	World Food Day
21st October	Global Iodine Deficiency Disorder Prevention Day
24th October	United Nations Day
10th November	World Immunization Day
1st December	World AIDS Day
10th December	Human Rights Day
23rd December	Farmers Day

APPENDIX D WORLD HEALTH DAY (APRIL 7) THEMES

1950	Know your own health services
1951	Health for your child and world's children
1952	Healthy surroundings make healthy people
1953	Health is wealth
1954	The nurse, pioneer of health
1955	Clean water means better health
1956	Destroy disease carrying insects
1957	Food and health
1958	Ten years of health progress
1959	Mental illness and mental health in world today
1960	Malaria eradication, a world challenge
1961	Accidents need not happen
1962	Preserve sight, prevent blindness
1963	Hunger-Disease of millions
1964	No truce for tuberculosis
1965	Smallpox constant alert
1966	Man and his cities
1967	Partners in health
1968	Health in the world of tomorrow
1969	Health, labour and productivity
1970	Early detection of cancer saves lives
1971	A full life despite disabilities
1972	Your heart is your health
1973	Health begins at home
1974	Better food for healthier world
1975	Smallpox: Point of no return
1976	Foresight prevents blindness
1977	Immunize and protect your child
1978	Down with high blood pressure
1979	A healthy child a sure future
1980	Smoking or health, the choice is yours
1981	Health for all by the year 2000 AD
1982	Add life to years
1983	Health for all by 2000 AD: Count down has begun
1984	Children's health tomorrow's wealth
1985	Healthy youth our best resource
1986	Healthy living: Every one a winner
1987	Immunization: A chance for every child
1988	Health for all, all for health
1989	Let us talk health
1990	Our planet, our health: Think globally, act locally
1991	Disaster: Are we prepared?
1992	Heart beat: The rhythm of health
1993	Handle life with care: Prevent Violence and negligence
1994	Oral health for a healthy life
1995	Target 2000: A world without polio
1996	Healthy cities for better life
1997	Emerging infectious diseases: Global alert, global response
1998	Safe motherhood: Pregnancy is special, let's make it safe
1999	Active aging makes the difference
2000	Safe blood starts with me: Blood saves lives
2001	Stop exclusion: "Dare to Care"
2002	Move for health
2003	Shape for future of life
2004	Road safety is no accident
2005	Make every mother and child count
2006	Working together for health
2007	International health security
2008	Protecting health from climate changes

APPENDIX E WORLD BREASTFEEDING WEEK (AUGUST 1 TO 6) THEMES

- 1992 Baby-friendly hospitals
- 1993 Mother-friendly workplace
- 1994 Protect breastfeeding: making the Code work
- 1995 Breastfeeding: Empowering women
- 1996 Breastfeeding: A community responsibility
- 1997 Breastfeeding: Nature's way

- 1998 Breastfeeding: The best investment
- 1999 Breastfeeding and education
- 2000 Breastfeeding: It's your right
- 2001 Breastfeeding in the information age
- 2002 Healthy mothers and healthy babies
- 2003 Breastfeeding in a globalized world for peace and justice
- 2004 Exclusive breastfeeding: Safe, sound and sustainable
- 2005 Breastfeeding and Family foods — Loving and healthy
- 2006 The IMS act: Making it known to people
- 2007 Breastfeeding: The first hour — Save one million babies
- 2008 Mother's support: Babies going for the gold

APPENDIX F THE IMNCI CASE MANAGEMENT PROCESS

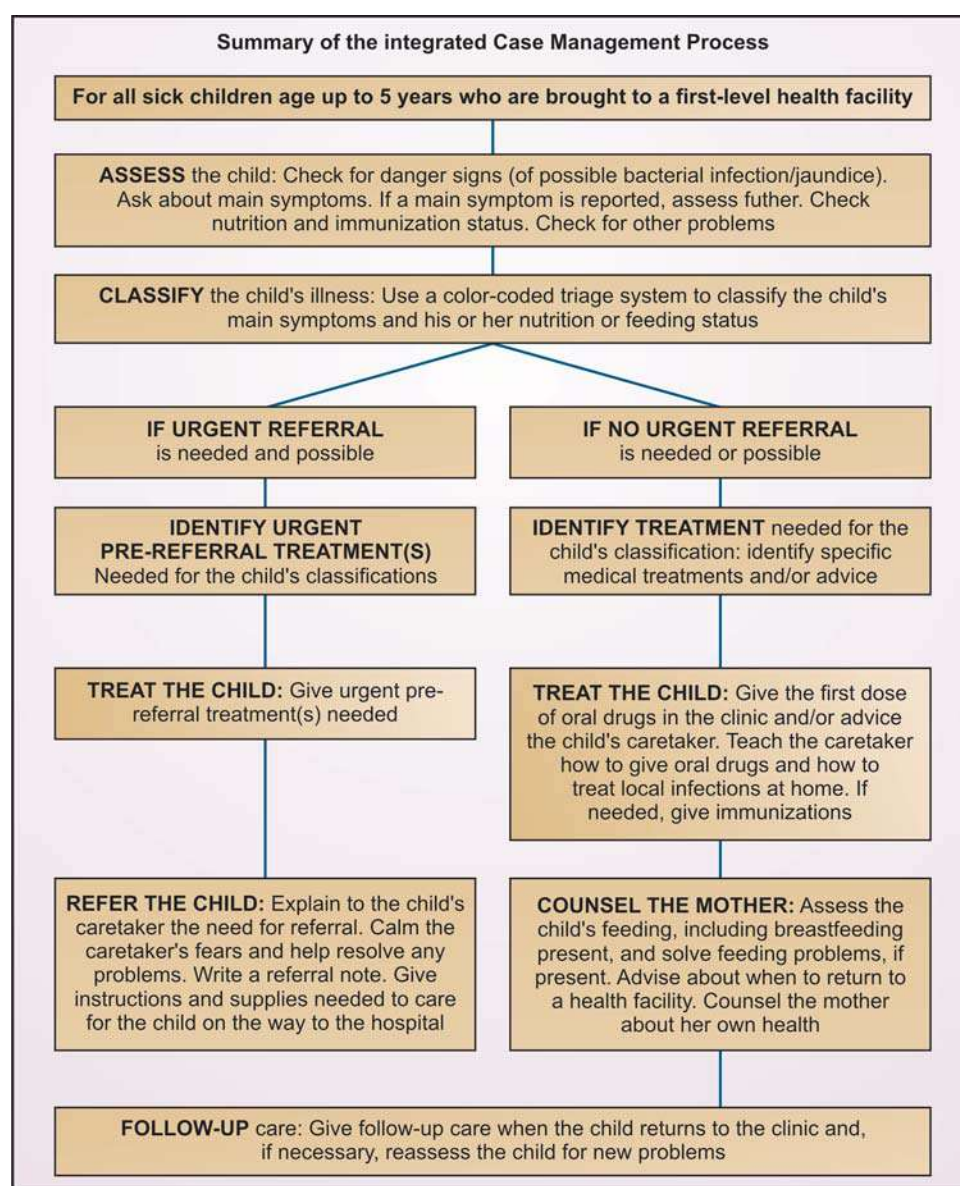

APPENDIX G

IMNCI CASE MANAGEMENT IN THE OUTPATIENT HEALTH FACILITY, FIRST-LEVEL REFERRAL FACILITY AND AT HOME FOR THE SICK YOUNG INFANT UP TO 2 MONTHS AGE

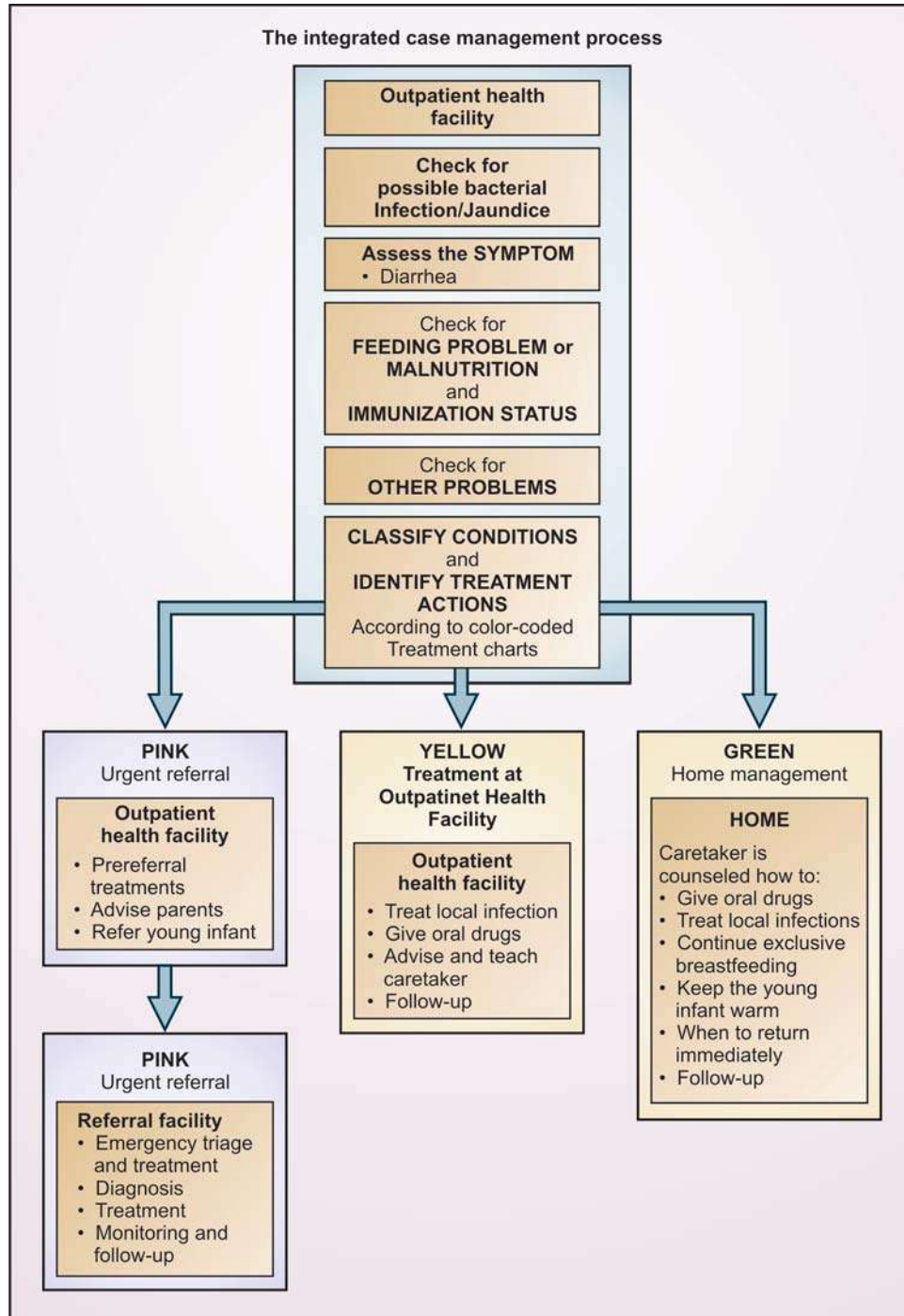

APPENDIX H

IMNCI CASE MANAGEMENT IN THE OUTPATIENT HEALTH FACILITY, FIRST-LEVEL REFERRAL FACILITY AND AT HOME FOR THE SICK CHILD FROM AGE 2 MONTHS UP TO 5 YEARS

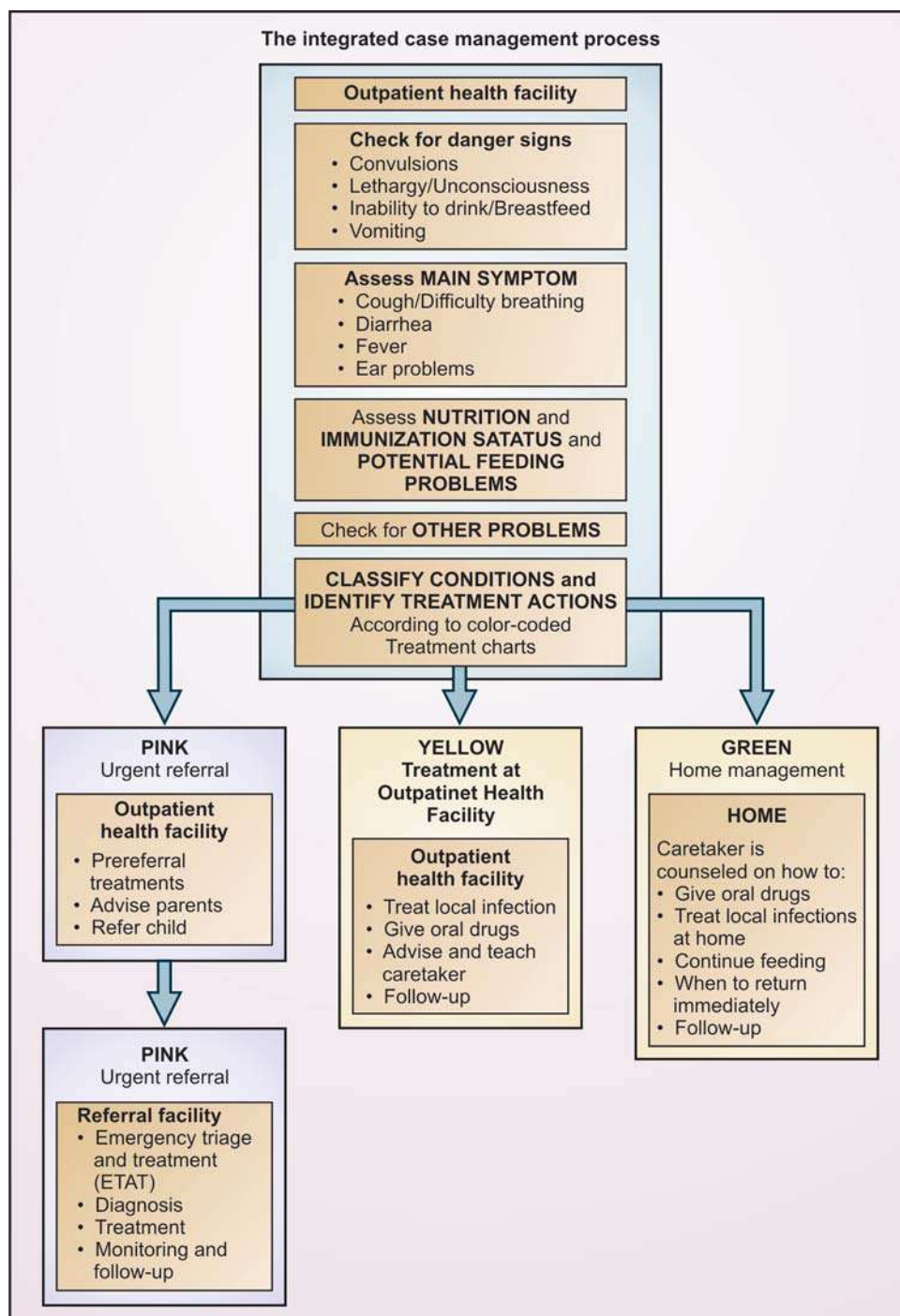

APPENDIX I

SYLLABUS MODULE OF DIDACTIC TEACHING FOR UNDERGRADUATES AS PER RECOMMENDATION OF THE MEDICAL COUNCIL OF INDIA (MCI)

(* Student MUST KNOW all the below listed topics except those marked with an astrisk which they SHOULD KNOW)

1. Introduction to Pediatrics

- 1.1 Importance of child health and its determinants, approach to a child patient and his/her family.
- 1.2 Age distribution of pediatric patients, anatomical and developmental factors affecting childhood illnesses.
- 1.3 Common causes of childhood morbidity and mortality and indices of child health.
- 1.4 First-aid procedures: cardiopulmonary resuscitation, shock, anaphylaxis and common poisonings.
- 1.5 National programs pertaining to child health.

2. Growth and Development

- 2.1 Definitions, determinants of growth, assessment of growth and concept of percentiles.
- 2.2 Growth and sexual development during childhood and adolescence, anthropometry, velocity of growth, growth monitoring and road-to-health card.
- 2.3 Developmental milestones, determinants of normal development and factors affecting development of children.
- 2.4 Assessment of development: gross motor, fine motor, language, social and adaptive, concept of DQ.
- 2.5 Approach to a child with failure to thrive, growth retardation and short stature.

3. Nutrition and Its Disorders

- 3.1 Age-related requirements of calories, nutrients, vitamins, minerals and trace elements.
- 3.2 Infant feeding practices: breastfeeding, artificial/bottle feeding and weaning.
- 3.3 Protein-energy malnutrition: ecology, diagnosis, anthropometry, growth charts and clinical features.
- 3.4 Associated deficiencies and complications of protein-energy malnutrition and its management.
- 3.5 Deficiency disorders related to fat soluble vitamins (vitamins 'A', 'D', 'E' and 'K').
- 3.6 Deficiency disorders related to water soluble vitamins.
- 3.7 Nutritional anemias in infancy and childhood.

4. Immunizations

- 4.1 Introduction, active and passive immunizations, national immunization schedule, contraindications and adverse reactions to vaccines.
- 4.2 UIP, EPI, cold chain, logistics, techniques of vaccinations, etc.

5. Fluid and Electrolytes

- 5.1 Pathophysiology of fluid, electrolytes and acid-base balance and principles of management (2 lectures).

6. Neonatology

- 6.1 Definitions, health indices, classification, identification of high risk newborn baby.
- 6.2 Care of newborn baby at birth including cardiopulmonary resuscitation.
- 6.3 Care of the normal newborn baby including breastfeeding.
- 6.4 Common minor development neonatal problems.
- 6.5 Neonatal infections including superficial infections, septicemia and tetanus neonatorum.
- 6.6 Problems and management of low birth weight babies in the hospital and community.
- 6.7 Common congenital malformations and identification of life threatening surgical emergencies in the newborn.
- 6.8 Neonatal jaundice.
- 6.9 Respiratory distress in a newborn baby.*
- 6.10 Effect of maternal medications on the fetus and suckling infant.

7. Infectious Diseases (I)

- 7.1 Common childhood exanthematous illnesses: measles, rubella, chickenpox
- 7.2 Mumps and whooping cough
- 7.3 Typhoid fever
- 7.4 Diphtheria
- 7.5 Tuberculosis (2 lectures).

8. Infectious Diseases/Parasitic Disorders (II)

- 8.1 Common infections: roundworms, thread-worms, hookworms, etc.
- 8.2 Malaria including cerebral malaria and its management.
- 8.3 Amebic dysentery and giardiasis.

9. Gastrointestinal System

- 9.1 Acute diarrhea and dysentery: epidemiology, etiology, pathophysiology and clinical manifestations.
- 9.2 Acute diarrhea: assessment of dehydration, management, including ORT and nutritional management.
- 9.3 Persistent diarrhea in infants.*
- 9.4 Abdominal pain in children.
- 9.5 Jaundice in a child.
- 9.6 Some common GI symptoms: vomiting, constipation, rectal bleeding.

10. Respiratory System

- 10.1 Acute upper respiratory infections including common cold, acute streptococcal pharyngitis, otitis media and croup.
- 10.2 Acute lower respiratory infections (pneumonias): epidemiology, etiology, clinical features, management, including community-based treatment and prevention.
- 10.3 Bronchial asthma.

11. Cardiovascular System

- 11.1 Congestive heart failure: causes, diagnosis and management.

- 11.2 Congenital heart disease.*
- 11.3 Rheumatic fever and rheumatic heart disease.

12. Genitourinary System

- 12.1 Acute glomerulonephritis, hematuria and related problems.
- 12.2 Nephrotic syndrome.
- 12.3 Urinary tract infections: acute and recurrent.

13. Hemato-oncology

- 13.1 Hemolytic anemias in children.*
- 13.2 Acute leukemias and lymphomas.*
- 13.3 Solid tumors in children.*

14. Central Nervous System and Neuromuscular Disorders

- 14.1 Epilepsy including febrile convulsions.
- 14.2 Pyogenic meningitis.
- 14.3 Tuberculous meningitis.
- 14.4 Cerebral palsy: etiology, classification, clinical features, management.
- 14.5 Mental retardation: etiology, clinical diagnosis and classification, preventable/treatable causes, simple laboratory screening and management.
- 14.6 Hydrocephalus and microcephaly.*
- 14.7 Myopathies.*
- 14.8 Acute poliomyelitis and its sequelae.

15. Endocrine System

- 15.1 Cretinism: causes, early diagnosis and management.*
- 15.2 Juvenile diabetes mellitus.*

APPENDIX J FINAL MBBS PART II (PEDIATRIC) EXAMINATION

Break-up

Theory	40 marks
Clinical	30 marks
Viva (theory)	10 marks
Internal assessment	20 marks
	(10 each for theory and practical)
Total	100 marks

Guidelines/Classifications

- Clinical
 - 2 Cases : Long case (1 hour) 15 marks
 - Short case (15 minutes) 10 marks
 - 2 Spotters : 5 marks
- Viva marks (5) are to be added to the theory marks
- After addition of the respective internal assessment marks, total theory marks come to 60 and practical marks to 50.

- The examiners are expected to conduct the examination in two pairs for two batches of candidates.
- Criteria for passing the examination are 50% in aggregate with a minimum of 50% in theory and 50% in clinicals/practicals.

APPENDIX K IMPORTANT WEBSITES ON PEDIATRICS AND ALLIED FIELDS

- INDIAN PEDIATRICS: www.indianpediatrics.net: This free site offers full text electronic version of the journal "Indian Pediatrics" and should be of particular interest to the pediatric postgraduates, residents and other scholars and practitioners eager to remain abreast of the pediatric scenario in India.
- INDIAN JOURNAL OF PEDIATRICS: www.ijppediatric-sindia.org: This website hosts the electronic version of the oldest Indian journal in the field of child health. The journal is now published every month. The site provides original articles, special articles, symposia, clinical briefs, letters to the editor and abstracts.
- SYNOPSIS: www.pedsynopsis.com: This free site hosts the electronic version of the periodical, "Synopsis", a current survey of world literature in pediatrics, published quarterly from Detroit, USA. Each issue offers an indepth review article and summaries of articles on topical issues published in the world pediatric and allied literature with critical comments. Also incorporated is the "Morning Report at Children's Hospital at Michigan" which usually makes a very productive reading.
- AMERICAN ACADEMY OF CHILD AND ADOLESCENT PSYCHIATRY: www.aacap.org: This website hosts summaries of AACAP practice parameters. More importantly, it provides the full text of more than 50 "Facts for Families" that are fact sheets on latest and comprehensive information concerning children, adolescents and their families. An extension of this (website www.aacap.org/journal/journal.htm) takes you to the abstracts and table of contents (not the full articles) of Journal of the American Academy of Child and Adolescent Psychiatry.
- BRITISH PEDIATRIC SURVEILLANCE UNIT: <http://bpsu.repch.ac.uk>. The site, sponsored by the Royal College of Pediatrics and Child Health of United Kingdom, provides important details about uncommon as well as new childhood diseases. Through the site, the newsletter is also accessible.
- KIDS HEALTH: www.ama-assn.org/insight/h_focus/numerous/index.htm. The American Medical Association (AMA) and the Nemours Foundation have developed "The Kids Health" which is a useful source of information on children's health, primarily addressed to the parents and caregivers, even pediatricians would find it useful from the angle of education of their clients. The section on accident prevention is particularly remarkable.
- CLINICAL NOTEBOOK: NUTRITION LAB VALUES: <http://W3.uokhsc.edu/uguild/CN2Case/notebook.html>. This is an excellent site for lab values, formulas for energy requirements and notes on clinical nutrition course.
- UNDERSTANDING VITAMINS: <http://www.critpath.org/eric/library/altern03.htm>. Balanced and referenced articles

on vitamin supplementation are available in this site, especially in context of HIV / AIDS.

- **THE CRUSADE AGAINST MALARIA:** <http://www.malaria-ipca.com/> This is a valuable site for upto date information on malaria worldwide, including its types, classification, clinical presentation, diagnosis, treatment and guidelines for the travellers to the endemic areas.
- **PEDIATRIC INTERACTIVE DIALOGUE: WWW.JJPED.COM:** This fine website is hosted by the Department of Pediatrics, Institute of Child Health, Grant Medical College and JJ Group of Hospitals, Mumbai, India. For participation in interactive discussion, compulsory registration is a prerequisite.
- **PARASITIC DISEASES: www.dpd.cdc.gov/dpdx/:** This website is hosted by the Centre for Disease Control and provides, among other information, reviews of parasitic diseases globally. Health professional may seek answers related to digital images of specimens sent by them. No fee is involved.
- **CLINICAL INFECTIOUS DISEASES: www.journals.uchicago.edu/CID/:** This site incorporates issues from 1997 onwards of the journal. No charges are taken for access to abstracts and table of contents. However, full text is accessible to only subscribers on nominal payment.
- **DOCTOR SPEAK/ CONSUMER SPEAK:** This free site is hosted by the Indian Medical Portals, Mumbai, India. The "Doctor speak" section offers a prescription guide related to over 200 drugs, daily health news from the agency, Reuters, a journal containing case reports from various specialists and a medical library on diseases. The "Consumer speak" section offers a family medical reference library and a drug index for patients, including children.
- **LEARN ABOUT HEALTH: http://members.rediff.com/mededu/fle.htm:** This free but useful site, targeted at teenaged girls, is hosted by Dr. Tejinder Singh, Professor of Pediatrics, Christian Medical College and Hospital, Ludhiana, India. With the inclusion of adolescence in "pediatrics", it can assist the practising pediatricians in their zest to create awareness among young girls about their health, development and minor problems.
- **AMERICAN JOURNAL OF PERINATOLOGY: www.thieme.com/onGILJMAEEGDH/display/755:** This very useful site is free only as far as access to the table of contents and abstracts is concerned. For access to the contents, registration is required.
- **FREE MEDICAL JOURNALS.COM: www.freemedicaljournal.com:** This highly recommended site, hosted by Amedeo.com, the company famous for the noted "Vaccine Weekly", offers free access to the full contents of over a score of important journals.
- **REUTERS HEALTH: HTTP://WWW.REUTEURS HEALTH.COM/ :** This very important site, hosted by the reputed Reuters News Agency, offers news stories and summaries of articles from most international pediatric and other journals as also a searchable drug database. Except for the latest news and news of last 10 days. A nominal subscription is compulsory.
- **INTERNATIONAL CENTER FOR DIARRHEAL DISEASE RESEARCH (ICDDR): http://www.icddr.org.sg:** This site offers information on the activities of the ICDDR, Dhaka, Bangladesh, which is reputed for excellent work on diarrheal diseases with special reference to ORS, the most spectacular medical advance of the 20th century.
- **ATLAS OF GASTROINTESTINAL ENDOSCOPY: www.mindspring.com/-atlsouthgastro/atlas_1.html:** This indeed is a very fine website for those interested in endoscopic profiles. The clarity of the graphics and the effective commentary adds to its value.
- **EMERGING INFECTIOUS DISEASES: www.cde.gov/ncidod/EID/index.htm:** This free site is hosted by the Center for Disease Control and aims at combating emerging infectious diseases with special reference to emerging infections.
- **CHILDREN WITH DIABETES: www.childrenwithdiabetes.com/:** This site provides useful information for children with diabetes mellitus and their families. Pediatricians can recommend it to the interested parties.
- **ACTION FOR AUTISM: www.autism.india.org:** This fine site is hosted by an Indian charitable organization, Action for Autism that offers support and services to autistic children and those working for such children in South Asia. The site offers information about the activities of the organization as also information about various aspects of autism in India.
- **CHILDREN'S VACCINE PROGRAM: www.childrensvaccine.org:** This website is sponsored by the Microsoft giant, Bill Gate. It deals with the gigantic vaccination coverage in the developing world.
- **INTERNET RESOURCES FOR SPECIAL CHILDREN: www.irsc.org/:** This is a very useful website for obtaining information on needs of the special children (those with one or the other disability). Its prime aim is to boost public awareness in relation to disabled children.
- **NEONATOLOGY AND GENETICS LINKS FROM KAROLINSKA INSTITUTE: www.mic.ki.se/Diseases/c16.html:** This excellent site hosted by the Karolinska Institute Library, Sweden, provides an exhaustive collection of links to the internet resources related to genetic disorders and neonatology.
- **MIMS INDIA: www.mims-India.com:** This site provides the electronic version of the MIMS India, an upto date index of ethical preparations (concerning all medical fields, including pediatrics) available for prescription in India. It is updated every month.
- **NEONATAL MEDICINE: http://www.cs.nsw.gov.au/rpa/neonatal/default1.htm:** This excellent website from the Royal Prince Alfred Hospital, Sydney, Australia, is a spotlight on various protocols in the management of neonatal problems. Over and above this, you shall find information on clinical aids, drugs, procedures and links to resources in neonatology. It is available free of charge.
- **CELIAC DISEASE: www.celiac.org:** Straight from the famous Celiac Disease Foundation, provides patient information on various aspects of celiac disease. Besides a newsletter, you shall find useful information on screening, support groups and recent advances concerning celiac disease.

APPENDIX L
NEW (2006) WHO CHILD GROWTH STANDARDS

Weight-for-age GIRLS

Birth to 5 years (percentiles)

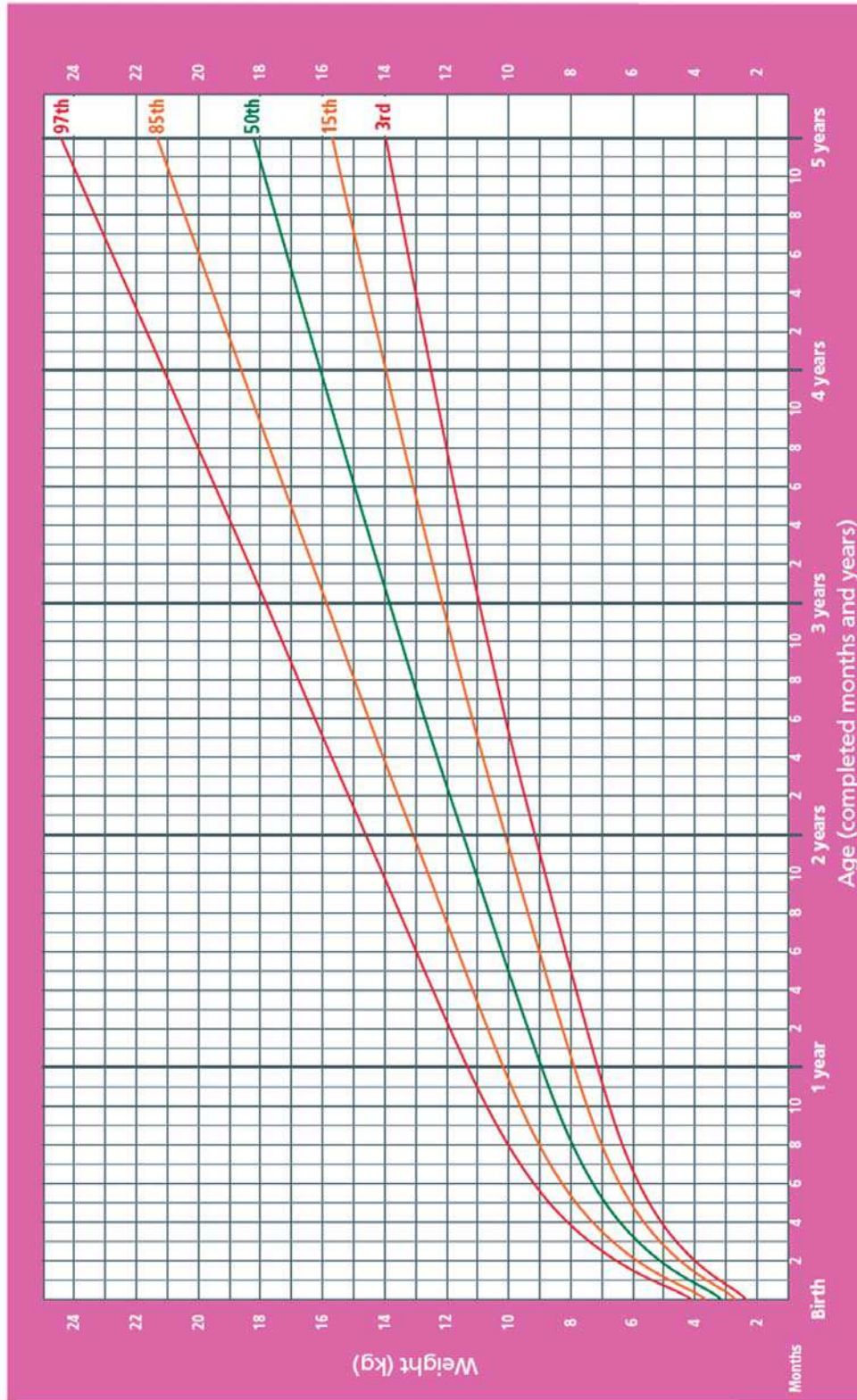

WHO Child Growth Standards

Weight-for-age GIRLS

Birth to 5 years (z-scores)

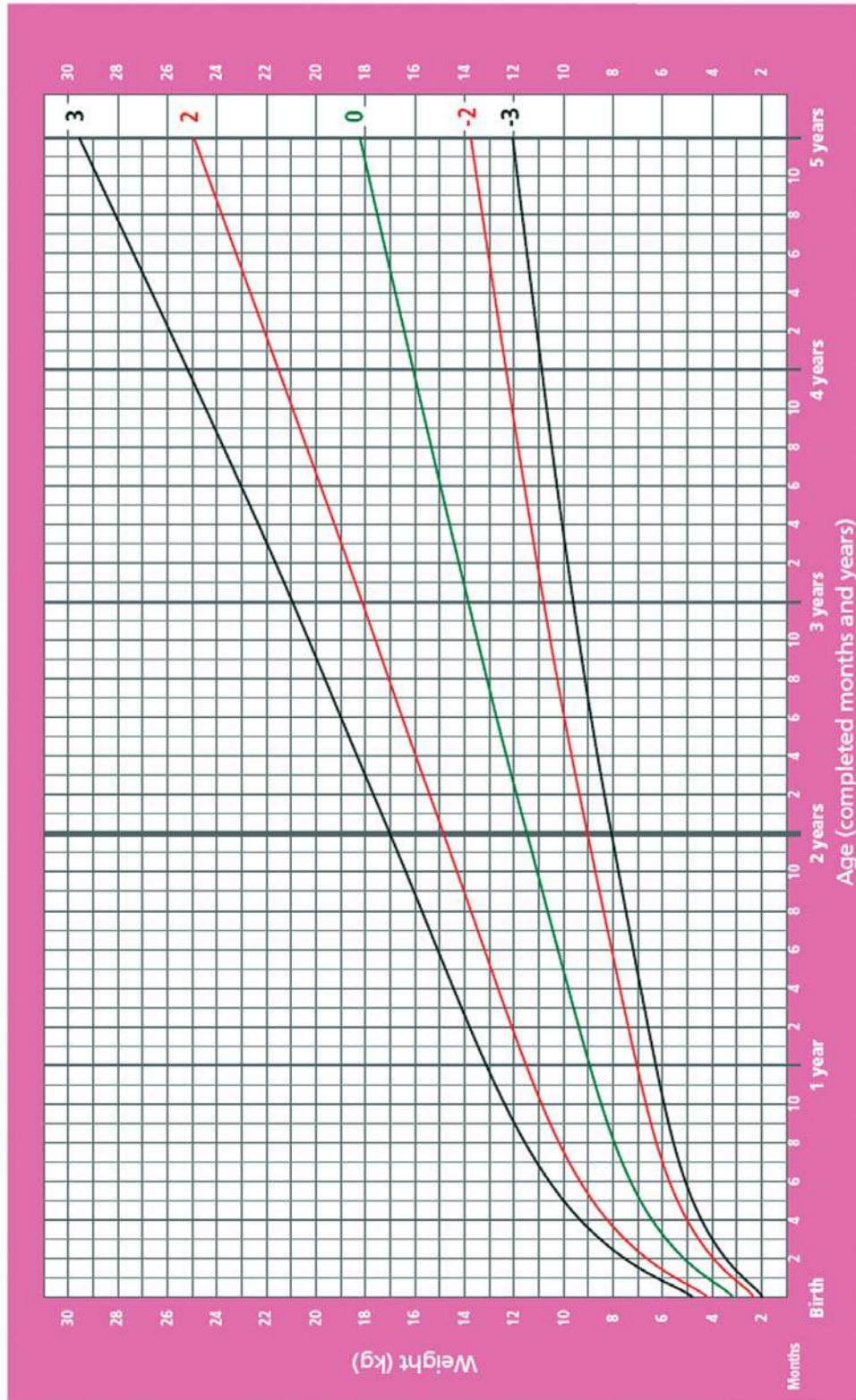

WHO Child Growth Standards

Weight-for-age BOYS

Birth to 5 years (percentiles)

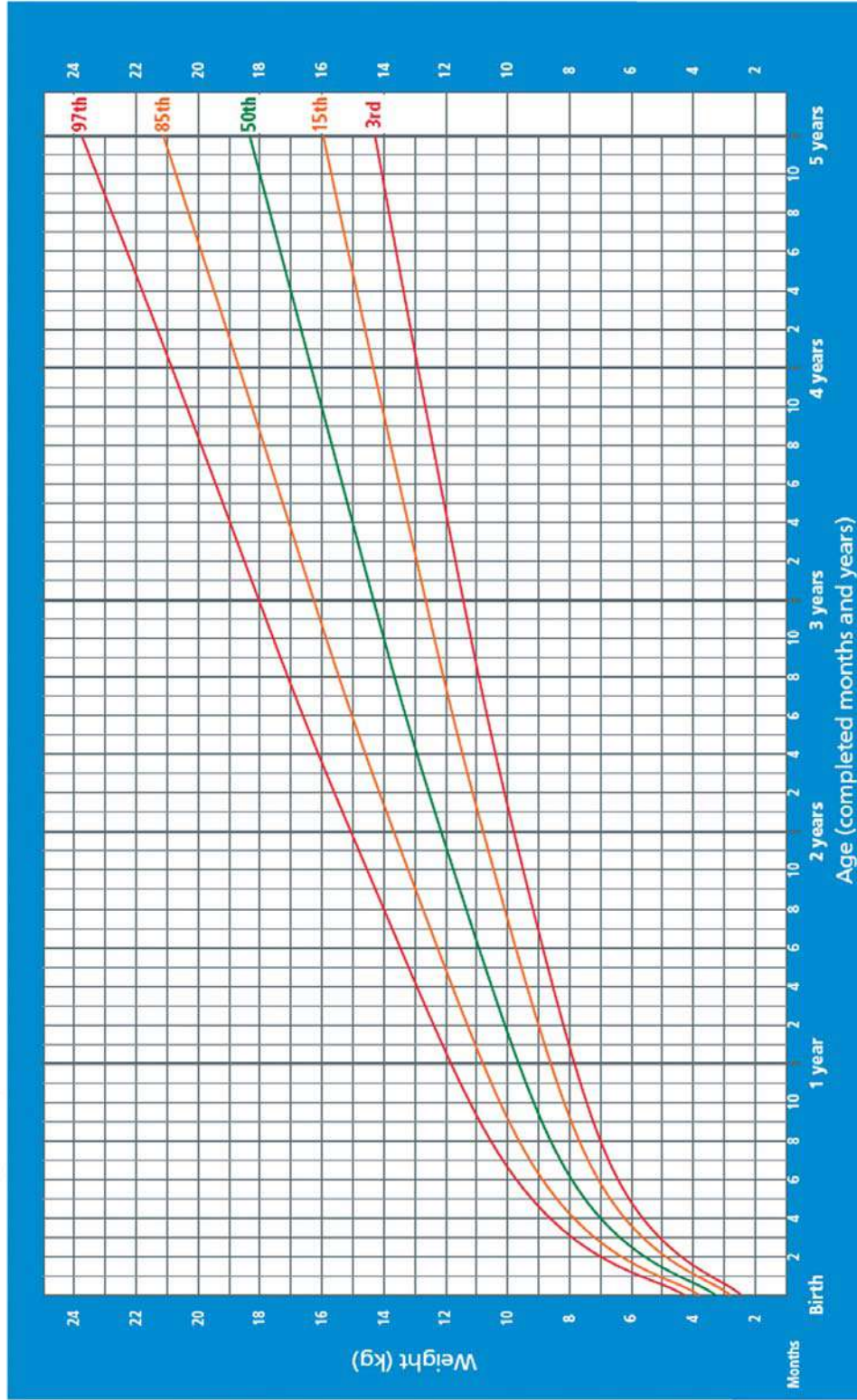

WHO Child Growth Standards

Weight-for-age BOYS



Birth to 5 years (z-scores)

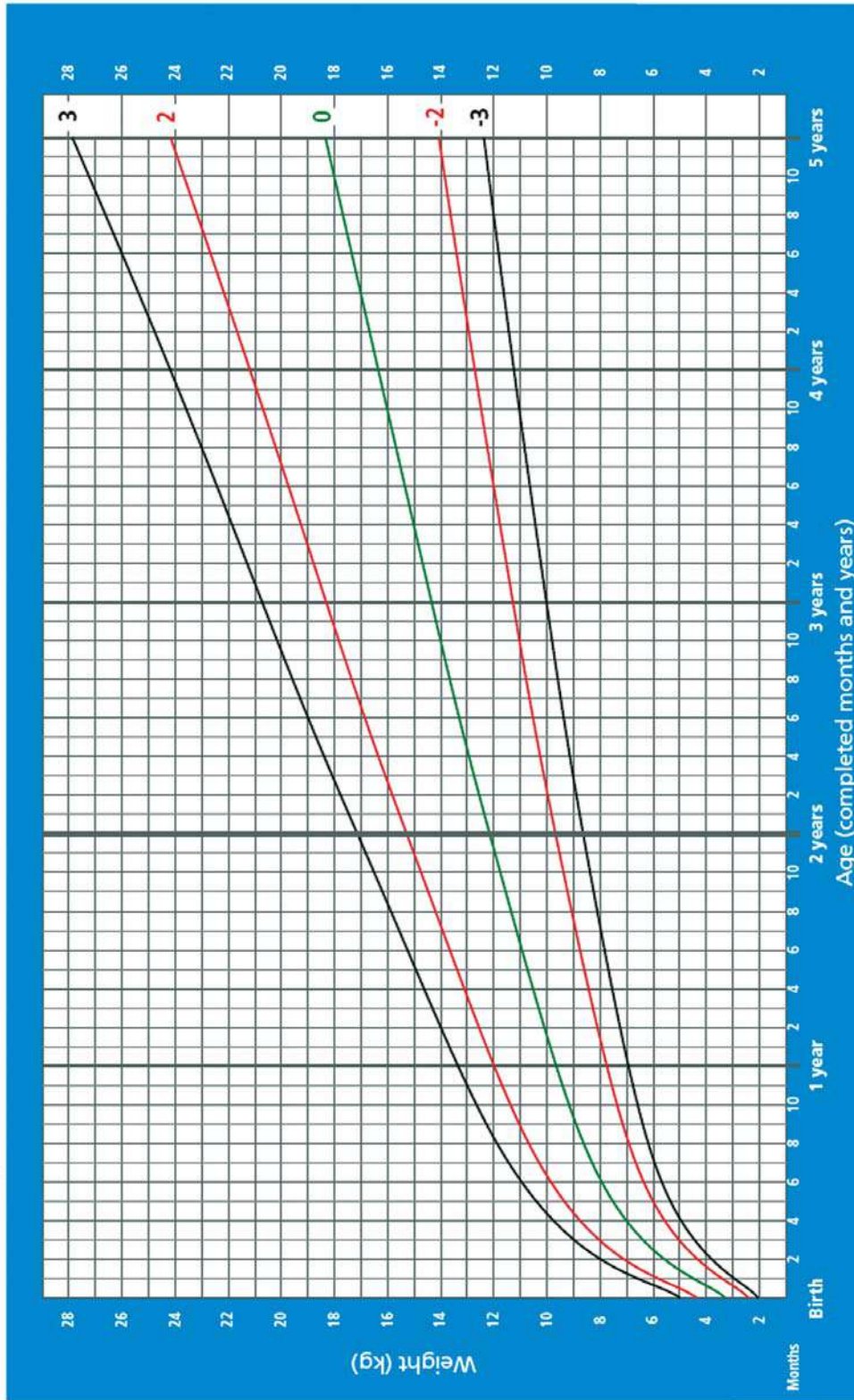

WHO Child Growth Standards

Length/height-for-age GIRLS



Birth to 5 years (percentiles)



WHO Child Growth Standards

Length/height-for-age GIRLS



Birth to 5 years (z-scores)

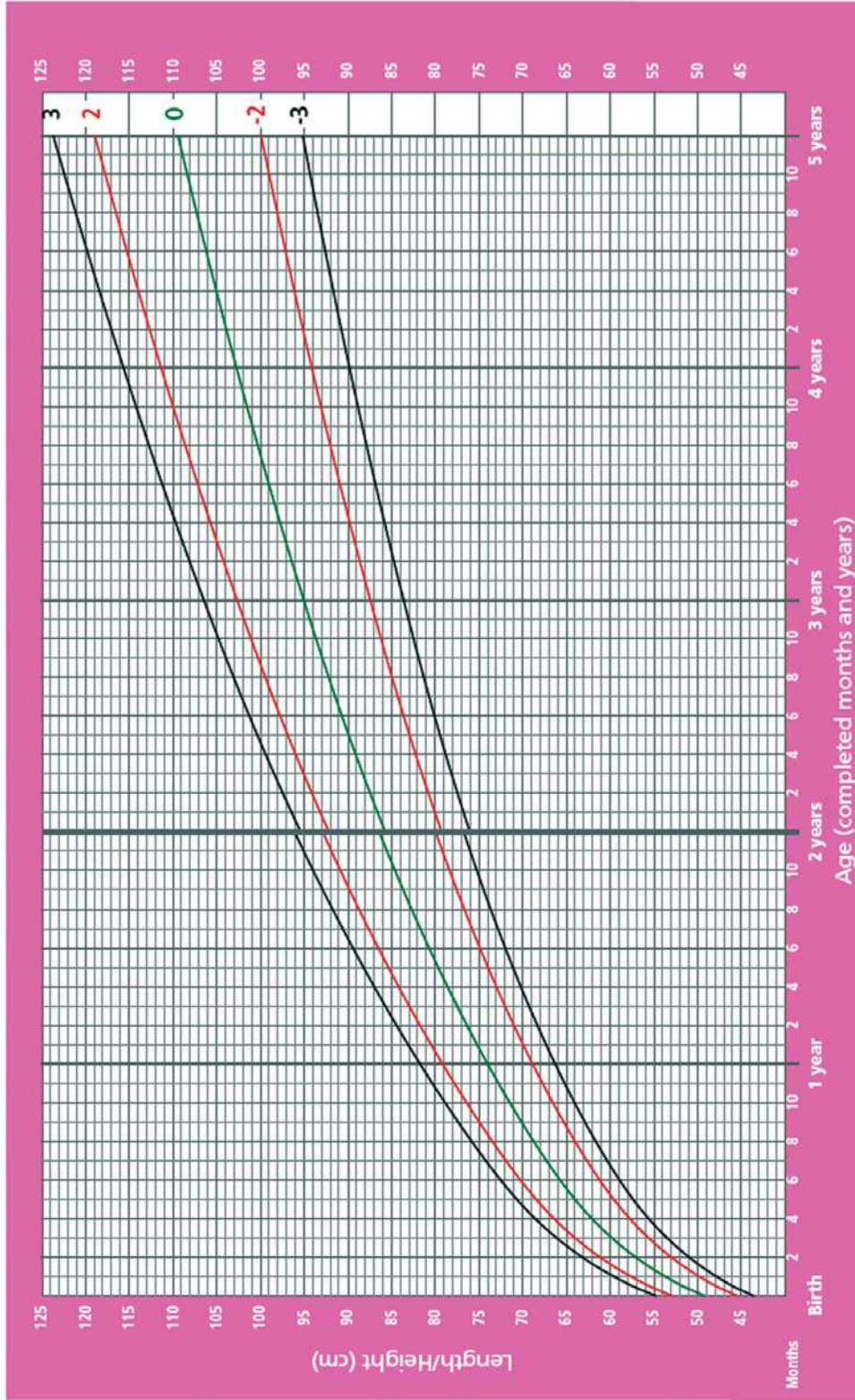

WHO Child Growth Standards

Length/height-for-age BOYS

Birth to 5 years (percentiles)

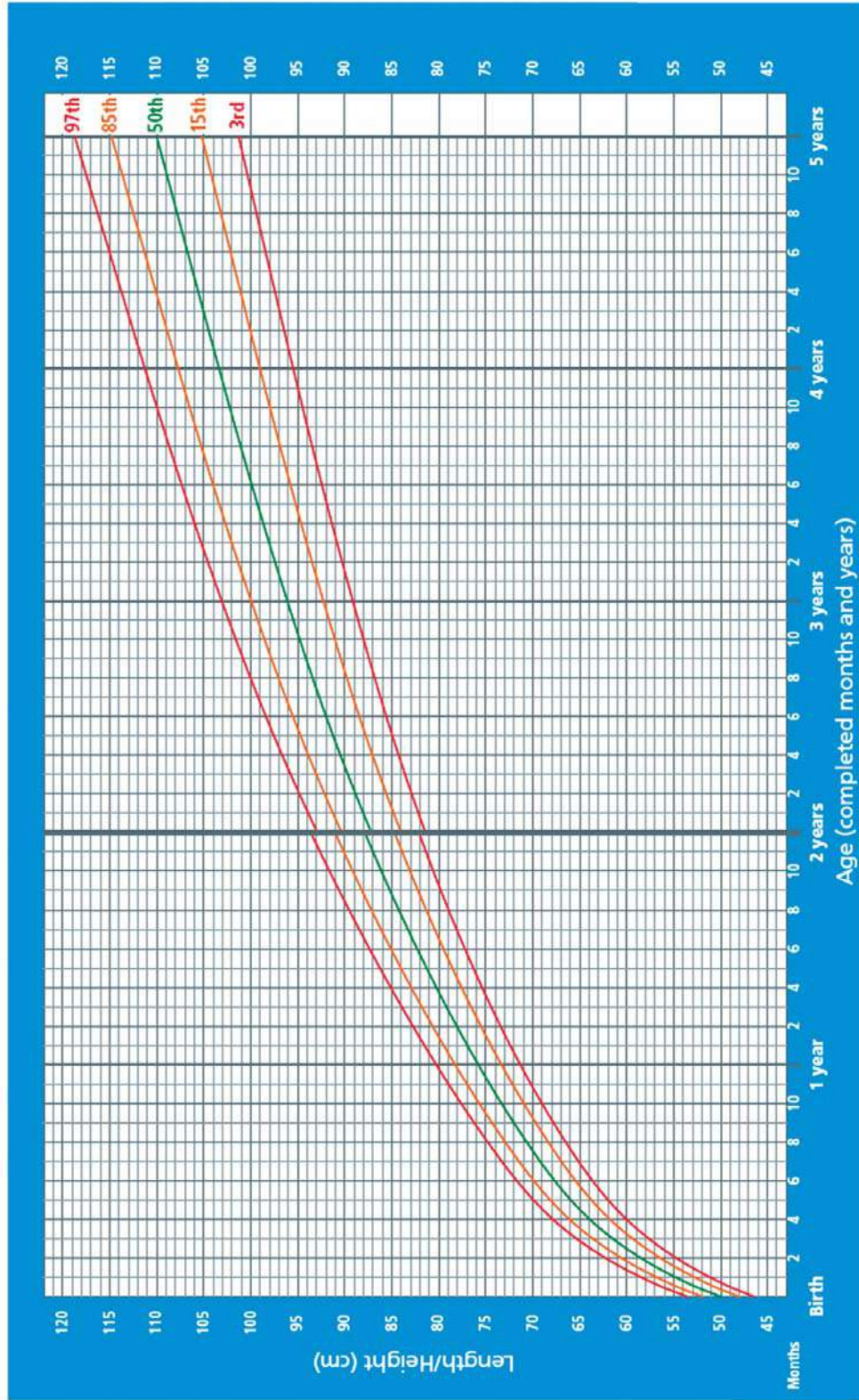

WHO Child Growth Standards

Length/height-for-age BOYS

Birth to 5 years (z-scores)

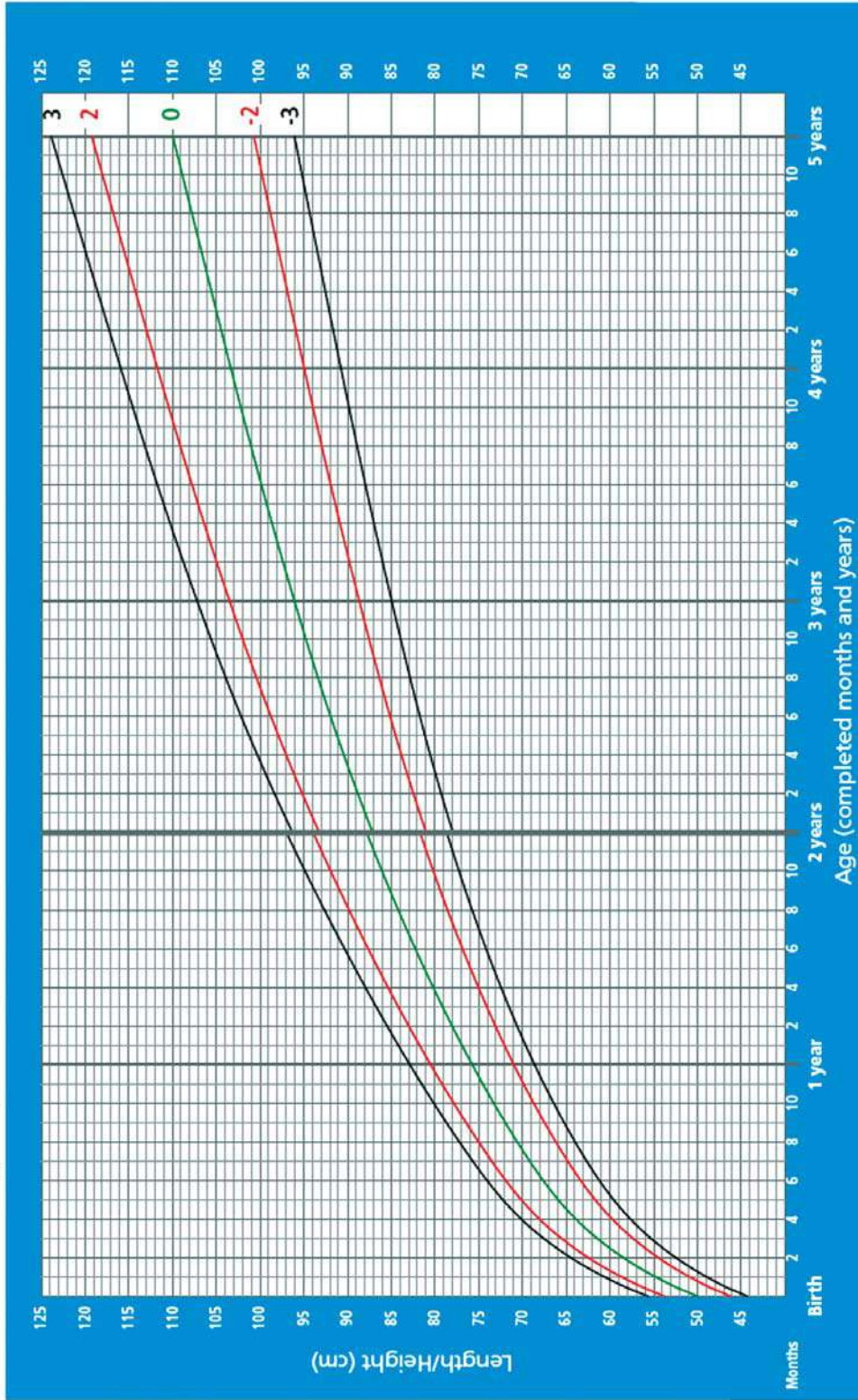

WHO Child Growth Standards

BMI-for-age GIRLS

Birth to 5 years (percentiles)

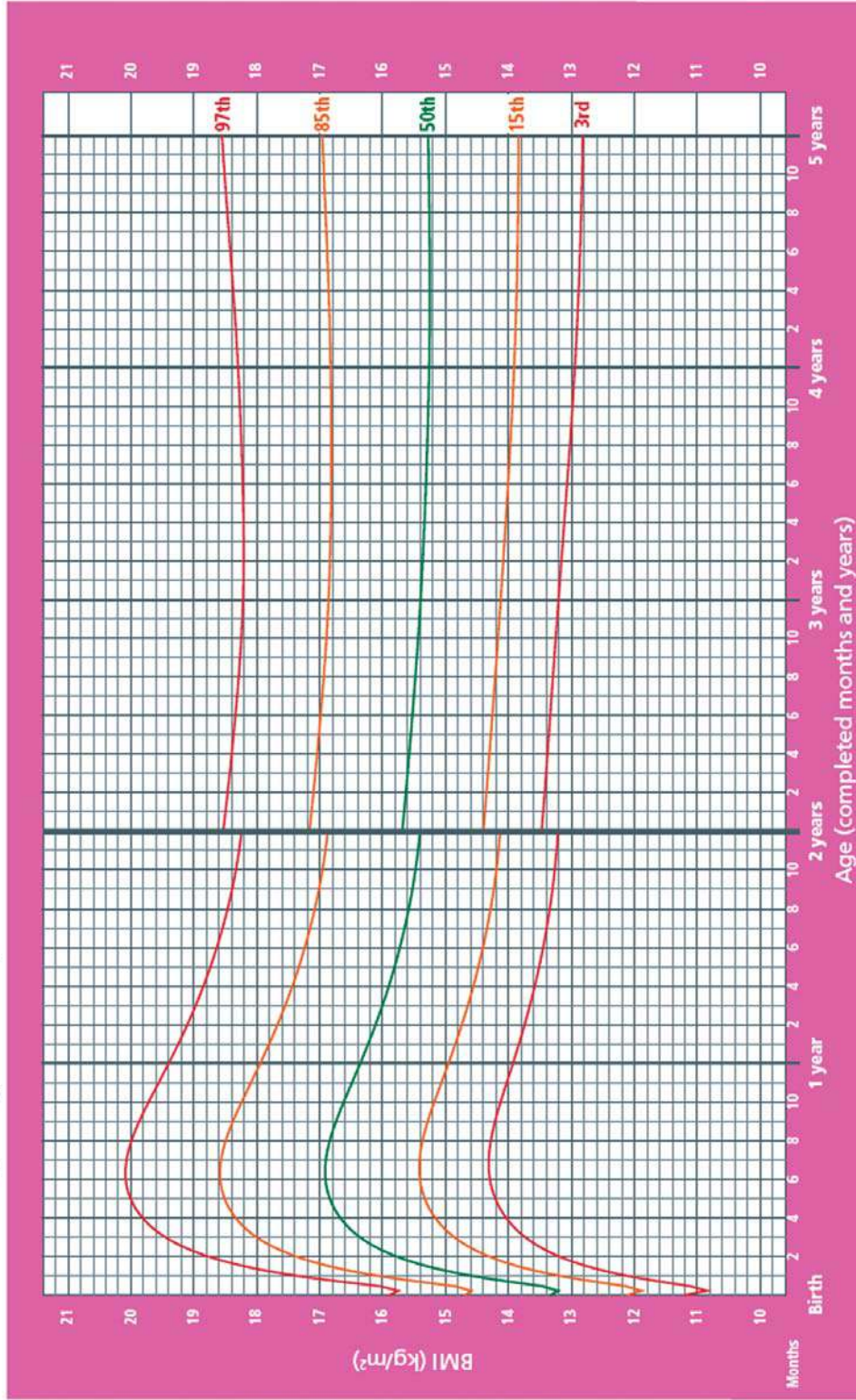

WHO Child Growth Standards

BMI-for-age GIRLS

Birth to 5 years (z-scores)

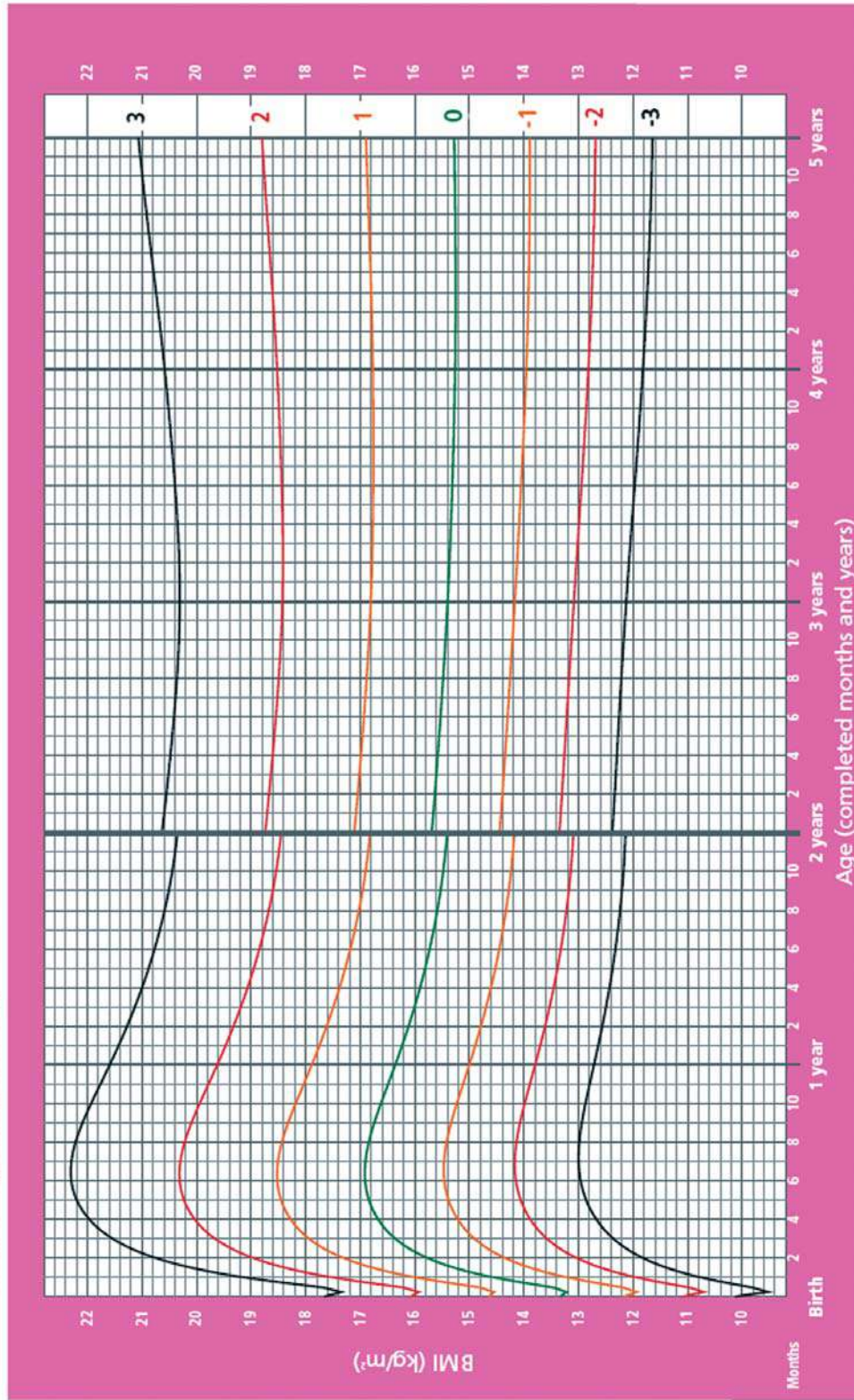

WHO Child Growth Standards

BMI-for-age BOYS

Birth to 5 years (percentiles)

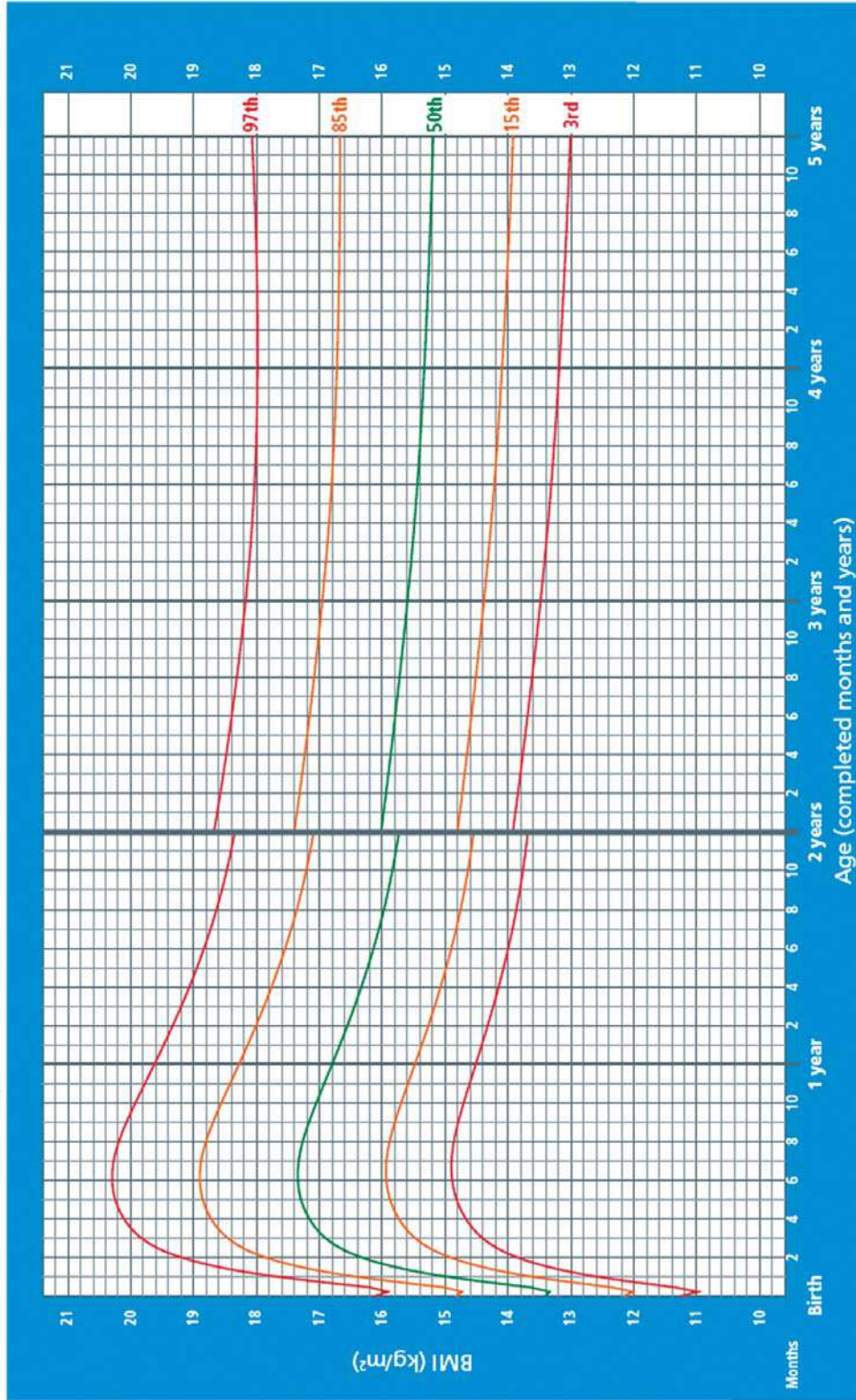

WHO Child Growth Standards

BMI-for-age BOYS



Birth to 5 years (z-scores)

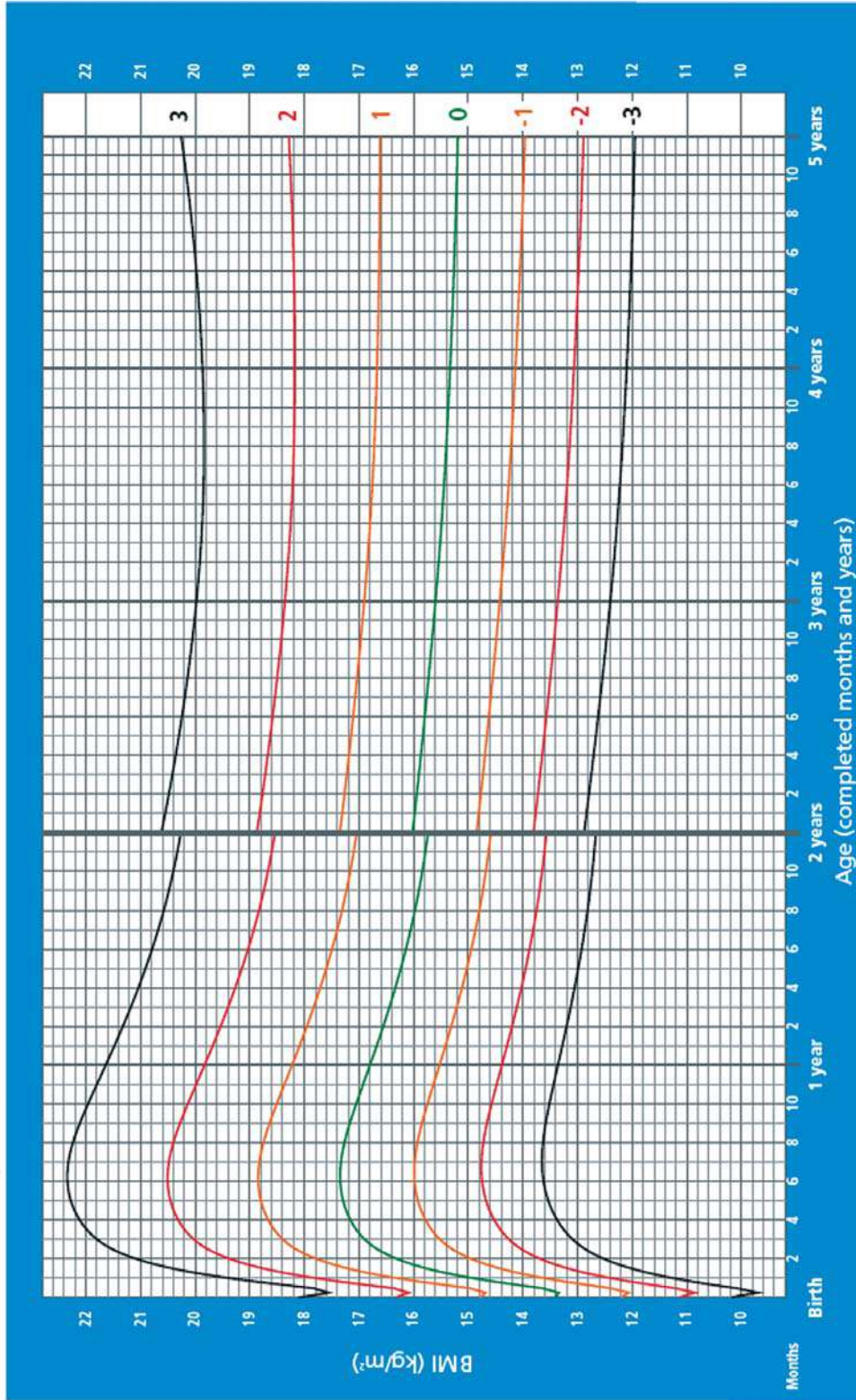

WHO Child Growth Standards

Index

A

- ABC of resuscitation 190
Abdominal paracentesis 750
ABO-hemolytic disease 237
Abscess 708
Acanthamoeba 310
Acardi syndrome 404
Accidental poisoning 608
Anhidrotic ectodermal dysplasia 605
Achondroplasia 714
Acid-base balance 176
Acidemia 179, 180
Acne 68, 605
 chloracne 605
 conglobata 606
 fulminans 606
 halogen 606
 infantile 606
 neonatal 606
 steroid 606
 tropical 606
 vulgaris 605
Acquired hypothyroidism 629
Acrobatic rickets 164
Acrodermatitis enteropathica 470
Activated charcoal 610
Activated partial thromboplastin time 540
Acute bacillary dysentery 454
Acute bronchiolitis 325
Acute bronchitis 324
Acute diarrhea 444
 clinical features 446
 clinical assessment 448
 severe diarrheal dehydration 447, 449
 complications 453
 etiology 444
 bacterial 445
 parasitic 446
 viral 445
 pathogenesis 446
 prognosis 453
 treatment 448
 ancillary measures 452
 chemotherapy 451
 conventional rehydration therapy 448
 diet 452
 symptomatic control 452
 WHO guidelines on management 450
Acute epiglottitis 687
Acute flaccid paralysis 95, 260
Acute glomerulonephritis 510
Acute inflammatory demyelinating polyradiculoneuropathy 406
Acute laryngotracheobronchitis 687
Acute nasopharyngitis 323
Acute otitis media 681
Acute pharyngitis 685
Acute renal failure 182, 513
Acute scrotum 707
Acute septic (pyogenic) arthritis 716
Acute stroke syndromes 405
Adaptation hypothesis 134
Addison disease 630
Adenoidal hypertrophy 686
Adenoids 686
Adjustment reaction 52
Adolescence 60
 factors influencing health 62
 health education 69
 nutrition 64
 psychology 63
 psychosocial problems 64
 puberty changes
 morphological 60
 psychological 61
 sexuality 63
 three stages 60, 61
 violence 66
Adolescent nutritional dwarfing 170
Adoption 95
Adoption laws 723
Adrenal and its disorders 630
Adrenal cortex 630
Adrenal hyperactivity 630
Adrenal insufficiency 630
Adrenal medulla 630
Adrenocorticotrophin hormone 624
Adult diabetes 635
Adult respiratory distress syndrome 323
Agenesis
 of corpus callosum 404
 of cranial nerves 404
Air bronchogram 216
Alacrima 671
Albinism 600, 648
Albright-McCune syndrome 624
Albumin infusion 520
Albuminocytologic dissociation 407
Algid malaria 299
Alkalemia 181
Alkaptonuria 648
Alma Ata Declaration 78
Alopecia 594
Amaurosis 676
Ambiguous genitalia 633, 706
Amblyopia 675
Amebiasis 309
Amebic liver abscess 501
Amelia 709
Amenorrhea 67
Ametropia 675
Amniocentesis 237
Amyoplasia 714
Anaerobic infections 288
Anal fissure 701
Anaparasana 119
Anaphylactoid (Henoch-Schoenlein) purpura 549
Anaphylactoid purpura 590
Anatomy of breast 115
Ancylostomiasis 313
Anemia control program 153
Anemia of infection 529
Anemia of lead poisoning 529
Anemia of protein-energy malnutrition 528
Anemia of thalassemia 530
Anemia/micronutrient deficiency 150
Anencephaly 192, 403
Anganwadi 85
Angiocardiography 355
Anhidrotic ectodermal dysplasia 604, 605
Aniridia 673
Anisocoria 673
Anisometropia 675
Ankyloglossia 732
Anorectal malformations 480
Anorectal problems 700
Anorexia nervosa 55, 64
Anthropometry 6, 131
Antigen presenting cells 572
Antioxidants 112
Antituberculous treatment 345
Aortic stenosis 373
Apert syndrome 429
Apgar score 195
Aplastic anemia 537
Apneic spells 219
Applied nutrition program 151
Aprotes 176
Arginine vasopressin 623
Arithmetic mean 72
Arterial blood gas analysis 322
Arterial puncture 747
Arterial thrombosis and embolism 405
Arthralgia 380

- Arthrogryposis multiplex congenita 714
 Artificial (formula) feeding 122
 Ascariasis 312
 Ascites 501
 Asperger's disorder 48
 Aspirin poisoning 614
 Assisted ventilation 754
 Astigmatism 675
 Ataxia or incoordination 435
 Ataxia telangiectasia 434, 577
 Atopic dermatitis 591
 Atrial septal defect 363
 clinical features 364
 complication 364
 diagnosis 364
 hemodynamics 363
 treatment 364
 Attention deficit hyperactivity disorder 47, 58
 Auspitz sign 606
 Australia antigen 494
 Autism 48, 58, 413
 Autistic spectrum disorder 48
 Autoimmune disease 580
 Autoimmune hemolytic anemia 537
 Autoimmune hypoparathyroidism 630
 Autonomic neuropathies 663
- B**
- Baby-friendly hospital initiative 80
 Bacterial meningitis 416
 Bag and mask ventilation 194, 754
 Balanitis 68
 Balanoposthitis 68
 Balwadi nutrition program 153
 Barbiturate poisoning 613
 Barlow syndrome 389, 512
 Base 176
 Battered baby syndrome 724
 B-cells defects 575
 BCGosis 100
 Becker muscular dystrophy 661
 Bedwetting 49, 55, 732
 Behavioral problems 51-53
 Behcet disease 590
 Bell palsy 406, 663
 Benign congenital hypotonia 658
 Benign intracranial hypertension 404
 Benign neonatal hemangiomatosis 203
 Benign rheumatoid nodules 588
 Bezoars 479
 Bilateral renal agenesis 505
 Bili blankets 232
 Bilirubin toxicity 237
 Biostatistics 71
 Bird (avian) flu 269
 Birth trauma 188
 Bitot's spot 156
 Black water fever 299
 Black-sickness 302
 Bleeding time 540
 Bleeding/hemostatic disorder 539
 Blepharitis 670
 Blepharospasm 670
 Block-Sulzberger disease 435
 Blood component therapy 553
 Blood examination 756
 Blood gas analyser 177
 Blood pressure measurement in children 394
 Blood transfusion 542
 Body mass index 34
 Bone age 35
 Bone marrow aspiration 748
 Bone marrow transplantation 569, 583
 Bone marrow trephine 749
 Bone tumors 566, 718
Bordetella 271
 Bottle addiction 127
 Bourneville disease 434
 Bow leg 164, 710, 732
 Bowel irrigation 610
 Brachial cyst 708
 Brachial sinus and fistula 708
 Brain abscess 425
 Brain tumors 565
 Brainstem tumors 565
 Brandt syndrome 470
 Breast abscess 119
 Breast disorders 67
 Breast engorgement 118
 Breast milk 212
 Breastfeeding 116, 212
 advantages/benefits 116
 for the community 117
 for the infant 116
 for the mother 117
 breastfeeding schedule 117
 contraindications 117
 problems 118
 technique and principles 118
 Breath-holding spells 55
 Bronchial asthma 334
 Bronchiectasis 330
 Bronchoscopy 322
 Brucellosis 280
 Bruxism 56
 Buffer 176
 Bulimia 55, 64
 Burping 213
- C**
- Café-au-lait spots 599
 Caffey disease 166
 Cancrum oris 294
 Candidiasis 226, 594
 Capillary hemangioma 600
 Caput succedaneum 188, 190, 203
 Carbohydrate malabsorption 70
 Carbohydrates 110
 Cardiac catheterization 355
 Cardiac examination 353
 Cardiac resuscitation 754
 Cardiomyopathy 391
 Cardiothoracic ratio 354
 Carditis 378
 Caries of spine 342
 Cartilage-hair hypoplasia 577
 Cataplexy 69
 Cataracts 673
 Categories of vaccines 97
 Catheterization 233
 Cavernous hemangioma 601
 Cavernous sinus thrombosis 428
 Celiac disease 465, 468
 Celiac rickets 165
 Cell-mediated immunity 573
 Cells of the immune system 572
 Centronuclear myopathy 658
 Cephalhematoma 188-190, 203
 Cerebellar tumors 565
 Cerebral gigantism 624
 Cerebral palsy 51, 413
 Chalazion 670
 Chédiak-Higashi syndrome 578
 Chemosis 672
 Chest compression 193, 195
 Chest infection 350
 Chickenpox (varicella) 248
 clinical features 248
 complication 249
 diagnosis 249
 etiopathogenesis 248
 prophylaxis 250
 treatment 249
 Chikungunya fever 263
 Child abuse and neglect 58, 93, 716, 724
 girl child 91
 Child adoption 723
 Child development project officer 85
 Child labor 86
 Child with ataxia 435
 Childhood diabetes 635
 Childhood scurvy 162
 Child-survival rate 84
 Chloroquine-induced psychosis 615
 Cholecystitis 498, 704
 acute acalculous 499
 with cholelithiasis 498
 Choledochal cyst 498, 703
 Cholera 453
 Cholestasis 235
 Chromosomal disorders 645
 Chromosomal studies 645
 Chromosomes 644
 Chronic diarrhea 462, 463
 Chronic Epstein-Barr virus infection 730

- Chronic fatigue syndrome 730
 Chronic granulomatous disease 577
 Chronic hepatitis 492
 Chronic mononucleosis 730
 Chronic otitis media 681
 Chronic renal failure 514
 Chvostek sign 201
 Circulatory changes at birth 356
 Classification of anemias 525, 525
 Cleft lip and cleft palate 692, 707
 Cleidocranial dysostosis 710
Clostridium 280
Clostridium difficile-associated diarrhea 455
 Club foot 709
 Clubbing 12
 CNS tuberculosis 417
 Coarctation of aorta syndrome 374
 Cold chain 98
 Colic 127
 Collagen diseases 291
 Coloboma 670
 Coma 436
 Combined immunodeficiency 577
 Common cold 323
 Community pediatrics 78
 Complement 571
 Complement defects 578
 Complementary feeding 120
 Computer application in pediatrics 735
 Concept of normal 71
 Congenital acholuric jaundice 532
 Congenital adrenal hyperplasia 634
 Congenital constriction bands/rings 710
 Congenital diaphragmatic hernia 190, 242, 696
 Congenital heart disease 359, 376
 Congenital hemolytic anemia 237, 532
 Congenital hypertrophic pyloric stenosis 694
 Congenital hypothyroidism 625, 626
 Congenital microcoria/miosis 673
 Congenital mydriasis 673
 Congenital nasolacrimal duct obstruction 671
 Congenital pseudoarthrosis of the tibia 710
 Congenital rubella 221
 Congenital rubella syndrome 253
 Congenital syphilis 220
 Congenital toxoplasmosis 221
 Congenital ureteropelvic junction obstruction 704
 Congestive cardiac failure 182, 357
 Conjugation 97
 Conjunctival diseases 671
 Conjunctival nevus 672
 Conjunctivitis 225, 671
 Consanguinity 5
 Constipation 202, 472
 Constricted pupil 673
 Construction of family pedigree 5
 Continuous positive airway pressure 755
 Convulsive disorders 430, 432
 Cooley anemia 532
 Corneal diseases 672
 Corneal light reflex tests 674
 Corneal ulcers 673
 Corticotrophin 624
Corynebacterium diphtheriae 273
 Cow milk allergy 470
 Craniofacial dysostosis 429
 Craniopharyngioma 566
 Craniostenosis 428
 Craniosynostosis 428
 Craniotabes 32
 Cretinism 625, 626
 Crossectional study 72
 Croup 687
 Crouzon's disease 429
 Crying in newborn 127
 Cryoprecipitate 554
 Cryptorchidism 68, 631, 707
 Cryptosporidiosis 311
 CSF examination 762
 CT scan 734
 Cushing syndrome 640
 Cyanosis 6
 Cyberhealth services 75
 Cybermedicine 75
 Cyproheptadine poisoning 615
 Cystic fibrosis 350, 467, 468
 Cystic hygroma 707
 Cytogenesis 400
 Cytomegalovirus disease 222
- D**
- Dacryocystitis 671
 Danger signs 210
 Data 71
 Datura (atropine) poisoning 616
 d-dimer assays 540
 DDT poisoning 613
 Deafness 682
 Degenerative brain disorders 438
 Dehydration 177
 Dehydration fever 126
 Delayed puberty 632
 Delayed speech 732
 Demyelinating disease 439
 Dendritic keratitis 672
 Dengue fever 261
 clinical features 262
 complications 262
 diagnosis 262
 differential diagnosis 262
 etiopathogenesis 262
 prevention 263
 treatment 263
 Dengue shock syndrome 262
 Dental caries 690
 Dental malocclusion 690
 Dental/oral hygiene 691
 Dentition 34, 690
 Depression 65
 Dermal zones 230
 Dermatoglyphics 654
 Dermatomyositis 587
 Dermatophycosis 594
 Dermatophytosis 594
 Desensitization 620
 Development 25, 37
 assessment 37
 Baroda DST 38
 Denver developmental screening test 38
 Trivandrum DST 38
 developmental screening 39
 Developmental delay 46
 Developmental dysplasia of the hip 711
 Devic disease 440
 Dextrocardia 393
 Diabetes insipidus 623
 Diabetes mellitus 634
 Diabetic coma 636
 Diabetic ketoacidosis 636, 637
 Diabetic retinopathy 677
 Diaper rash 595
 Diarrheal diseases 444
 Diastematomyelia 403
 Diastolic murmurs 10
 Differential leukocyte count 758
 DiGeorge syndrome 576, 630
 Dinner-fork sign 379
 Diphtheria 273, 687
 cutaneous 274
 facial 273
 laryngeal 274
 nasal 274
 Diplopia 676
 Directly observed therapy (DOT) 347
 Disability 89
 Disability prevention 89
 Discrimination
 against females 92
 against girl child 91
 Disease of lens 673
 Diseases of the eyelids 669
 Diseases of the retina and vitreous 676
 Disequilibrium syndrome 514
 Dislocation of patella 710
 Disorders of muscles 658
 Dispersion 72
 Disseminated disease 222
 Disseminated intravascular coagulation 540
 Distance communication 75
 DNA double helix 643
 Doll's eye phenomenon 436
 Doll's eye reflex 198

Double elevator palsy 674
 Down syndrome 410
 Drowning 351
 Drug abuse 57
 Drug eruption 592
 Drug-induced liver injury 499
 Drug-induced thrombocytopenia 549
 Drugs employed in asthma 336
 Dry eye 671
 Dry pleurisy 331
 Duchenne muscular dystrophy 659
 Duodenal and other intestinal atresias 697
 Duplex renal system 506
 D-xylose test 464
 Dyscoria 673
 Dyslexia 46, 676
 Dysmenorrhea 67
 Dysmorphic facies 190
 Dyspnea 5
 Dysrhythmism 402

E

Ear disorders 680
 Early infant mortality 83
 Eating problem 732
 Ebstein anomaly 370
 Echinococcosis 317
 Echocardiography 355, 733
 Ecology of malnutrition
 bad economy 129
 bad start 130
 closely-spaced families 130
 ignorance, faulty food habits and feeding 129
 large families 130
 medical reasons 130
 secondary malnutrition 130
 working mother 130
 Ectodermal dysplasias 604
 Ectopia lentis 673
 Ectropion 670
 Ehler-Danlos syndrome 590, 603
 Eisenmenger syndrome or complex 362, 371
 Electrocardiography 354
 Electrolytes 175
 Electronic mail 76
 Ellis-van Creveld syndrome 363
 Emerging and re-emerging infections 737
 Emmetropia 675
 Emphysema thoracis 333
 Encephalitic disease 222
 Encephalitis 421
 Encephalitis-like syndrome 150
 Encephalocele 403
 Encopresis 55
 Endemic goiter 172
 Endemic tropical sprue 469
 Endocrinal myopathies 662
 Endocrine orchestra 623
 Endotracheal intubation 193, 194, 752
 End-stage renal disease 522
 Energy 109
 Enhanced inactivated polio vaccine 102
 Enophthalmos 668
 Enteric fever 277
 antibiotic therapy 279
 Entropion 670
 Enuresis 49, 55
 Eosinopenia 277
 Ependymoma 565, 566
 Epidemic parotitis 254
 Epidemic typhus 275
 Epidermolysis bullosa 601
 dermolytic 602
 epidermolytic 601
 junctional 602
 Epididymo-orchitis 707
 Epispadias 706
 Epistaxis 683
 Epstein pearls 203
 Erb paralysis 188, 189
 Erysipelas 597
 Erythema
 marginatum 379
 multiforme 602
 nodosum 604
 toxicum 202
 Erythrocyte sedimentation rate 758
 Erythrocytosis 552
 Esophageal atresia 695
 Evidence-based medicine 737
 Ewing sarcoma 567
 Exchange blood transfusion 232, 752
 Exomphalos 701
 Exophthalmos 668
 Expressed breast milk 124
 Extrahepatic biliary atresia 498, 702
 Extrahepatic portal hypertension 495

F

Facial palsy 418
 Facioscapulohumeral muscular dystrophy 662
 Failure to thrive 40
 Fallot's physiology 368
 Family health 79
 Fanconi syndrome 164
 Fascitis 588
 Fatal sting 621
 Fats 111
 Febrile seizures 430
 atypical (complex) 431
 typical (simple) 430
 Feeding problems 126
 Feeding the low birthweight infant 12, 213
 Female feticide/infanticide 91
 Fetal circulation 356

Fiberoptic phototherapy 232
 FIGLU test for folate deficiency 531
 Filariasis
 clinical features 305
 diagnosis 306
 treatment 306
 Fine needle aspiration 752
 Fissure-in-ano 701
 Flat foot 709, 733
 Flexural eczema 592
 Floppy baby syndrome 663
 Floppy or billowing mitral valve syndrome 389
 Fluid and electrolyte therapy 181
 Fluoride and fluoridation 691
 Fluorosis 691
 Folate deficiency 530
 Fontanel and sutures 32
 Food allergy 478
 Foreign bodies
 in the ear 680
 in lower respiratory tract 323
 in nose 683
 Fourth ventricle tumor 565
 Fracture zone 162
 Free radicals 112
 Fröhlich syndrome 624
 Frontal encephalocele 191
 Full-term newborn 196
 Fulminant hepatitis 490
 Fulminant/acute hepatic failure 490
 Functions of liver 481
 Fundus ophthalmicus 157
 Funnel-chest deformity 165

G

G-6-PD deficiency 235, 536
 Galactosemia 649
 Gallop rhythm 9
 Gangrenous stomatitis 294
 Gastric lavage 610, 753
 Gastrointestinal bleeding 476
 Gastrointestinal decontamination 610
 Gastrointestinal problems 694
 Gastrointestinal tract 443
 Gastroschisis 701
 Gastroesophageal reflux disease 475
 Gated blood pool scanning 355
 Gaucher disease 650
 Gavage (tube) feeding 123
 Gender bias 90
 Gender gap 90
 Gene therapy 642, 655
 Genetic counseling 655
 Genetic disorders 644
 Genetic skeletal dysplasias 712
 Genetic traits 44
 Genetics 642
 Genitourinary problems 704

- Genome project 644
 Genu valgum 710, 732
 Genu varum 710, 732
 Geographic tongue 474
 Geophagia 54
 German measles
 clinical features 253
 diagnosis 254
 treatment 254
 Gestational age 209
 Ghon focus 340
Giardia lamblia 308
 Girdiasis 308
 Girl child 90
 Girl child week 91
 Gliomas 566
 Glossitis areata migrans 474
 Glycogen storage disease 649
 Goiter 629
 Goiter control program 153
 Gomez syndrome 149
 Gonadotrophins 624
 Gonads and their deficiency 631
 Goodpasture syndrome 588
 Gowers sign 660
 Grades of breathlessness 4
 Grading of splenic size 11
 Growing pains 730
 Growth 25
 factors influencing growth and development 25
 indices for assessment 28
 body ratio 31
 growth velocity 31
 head 31
 length/height 30
 weight 28
 weight for height 30
 law (principles) 27
 body proportions 28
 growth spurts 28
 order of growth 27
 postnatal growth pattern 27
 types of body build 28
 period 27
 Growth hormone 624
 Growth studies 25
 Grunting 350
 Guillain-Barré syndrome 259, 406, 407, 663
 Gynecomastia 68
- H**
- H. pylori* infections 478
 Habit spasm 56
 Hair tuft 192
 Hansen disease 282
 Harlequin fetus 598
 Harlequin color change 203
 Hartnup disease 648
 Head circumference 31
 Head/chest circumference ratio 32
 Health 78
 Health hazards 87
 Hearing impairment 682
 Heat hyperpyrexia 736
 Heat injury 736
 Heel puncture 751
Helicobacter pylori infection 288
 Hemangioma 600
 Hematocrit 756
 Hematopoietic system 522
 Hematuria 507
 Hemihypertrophy 711
 Hemimelia 709
 Hemiplegia of childhood 405
 Hemoglobin 756
 Hemolysis 531
 Hemolytic anemias 531
 Hemolytic crisis 535
 Hemolytic disease of the newborn 236
 Hemolytic-uremic syndrome 516
 Hemophilia 544
Hemophilus influenzae B disease 270
 Hemopoietic stem cell transplantation 552
 Hemorrhagic disease of the newborn 168, 228, 542
 Henderson-Hasselbach equation 177
 Heparinized saline 233
 Hepatic encephalopathy 490
 Hepatobiliary system 481
 Hepatoblastoma 564
 Hepatolenticular degeneration 440, 501
 Hereditary motor-sensory neuropathies 663
 Hereditary spherocytosis 532
 Hermaphroditism 633
 Herpes simplex 222
 Heterochromia 673
 Heterotropia 674
 Hiatal hernia 295, 480
 Hiccup (hiccough) 204
 High-risk pregnancy 186
 Hilar lymphadenitis 340
 Hindu Adoption and Maintenance Act, 1956 723
 Hirschsprung's disease 699
 Hirsutism 68
 Histiocytosis 730
 Histogenesis 400
 History taking 3
 Hodgkin's disease 559
 Holt-Oram syndrome 363, 364
 Homocystinuria 648
 Homosexuality 63
 Hookworm 313
 Hordeolum 670
 Horse-shoe kidneys 505
 House-dust mite 334
 Human cell division 642
 Human milk fortifiers 124
 Humoral immunity 572
 Hurler syndrome 628, 652
 Hutchinson-Gilford syndrome 729
 Hyaline membrane disease 215
 Hydatid disease 317
 Hydrocele 68, 204, 706
 Hydrocephalus 423
 acquired 420, 423, 424
 congenital 423, 424
 Hydrophobia 264
 Hydrops fetalis 236
 Hymenal tags 204
Hymenolepis nana 315
 Hyperadrenocorticism 630
 Hyper-IgE syndrome 578
 Hyperkalemia 179
 Hypermetropia (hyperopia) 675
 Hypernatremia 178
 Hyperparathyroidism 630
 Hypertelism 667
 Hypertension 394, 521
 Hypertensive retinopathy 677
 Hyperthyroidism 629
 Hypertrophy of pharyngeal tonsils 686
 Hyperventilation syndrome 58
 Hypervitaminosis 158
 Hypochromic anemias refractory to iron 529
 Hypochromotrichia 727
 Hypogeusia 171
 Hypokalemia 179
 Hyponatremia 177
 Hypoplastic left heart syndrome 373
 Hypospadias 706
 Hypotelorism 668
 Hypothalamus and its disorders 623
 Hypotonia 727
 Hypoxic-ischemic encephalopathy 213
 Hysteria 58
 Hysterical seizures 58
- I**
- Ibuprofen toxicity 614
 Ichthyosis 598
 Icterus gravis 236
 Immune dysfunction syndrome 730
 Immune response 97
 Immune thrombocytopenic purpura 546
 Immunity 97
 Immunization 97
 Immunodeficiency states 574
 primary 575
 secondary 578
 Immunoglobulins 573
 Immunologic memory 573
 Immunologic system 571
 Immunonutrition 173
 IMNCI case management process 789-791

Impairment 89
 Imperforate anus 242, 700
 Important conversions 785
 Inborn errors of metabolism 647
 Incontinentia pigmenti 435
 Incubator care 212
 India's national health programs 94
 India's national nutrition policy 95
 India's national nutrition programs 95
 Indian childhood cirrhosis 482, 483
 Indian Family of Cerebral Palsy 415
 Infant immobilization boards 744
 Infant mortality rate 83
 Infantile cortical hyperostosis 166
 Infantile hemiplegia 405
 Infantile polyarteritis 588
 Infantile scurvy 161
 Infantile skeletal proportions 627
 Infantile syncope 55
 Infantile tremor syndrome 173, 434, 726
 Infantometer 30
 Infants of diabetic mothers 240
 Infections in the newborn 220
 Infectious mononucleosis
 clinical features 260
 complications 261
 differential diagnosis 261
 etiopathogenesis 260
 treatment 261
 Infectious polyradiculitis 406
 Infective endocarditis 386
 Infective polyneuritis 406
 Inflammations of bones and joints 716
 Inflammatory bowel disease 471
 Information 71
 Inguinal hernia 480, 706
 Inhalation devices 337
 Innocent murmur 353
 Inotropic drugs 359
 Insect bite hypersensitivity 592
 Insomnia 69
 Integrated child development services
 scheme 84, 153
 Intelligence 71
 International days 788
 Internet 76
 Interstitial keratitis 672
 Interventional cardiac procedures 399
 Intestinal malrotation 697
 Intestinal obstruction 182
 Intracranial hemorrhage 405
 Intracranial space-occupying lesions 425
 Intracranial tumors 428
 Intractable seizures 433
 Intradermal injection 744
 Intrahepatic portal hypertension 494
 Intramuscular injection 744

Intraosseous infusion 747
 Intrapartum suctioning 192
 Intraperitoneal infusion 748
 Intravenous immunoglobulins 581
 Intravenous infusion 745
 Intubation 687, 752
 Intussusception 480, 698
 Iodine deficiency control program 153
 Iris coloboma 673
 Iron (iron salts) poisoning 615
 Iron-deficiency anemia 65, 525
 Irregular/asymmetrical skull 732

J

Jamaican cirrhosis 482
 Japanese encephalitis 263
 Jaundice 202
 Job syndrome 578
 Jugular vein puncture (JVP) 745
 Juvenile delinquency 66, 82
 Juvenile Graves disease 629
 Juvenile rheumatoid arthritis 584

K

Kala-azar
 clinical features 302
 complications 303
 epidemiology 302
 laboratory diagnosis 303
 polymerase chain reaction 304
 serological test 303
 treatment 304
 Kangaroo mother care 211
 Kawasaki disease 588
 Keratoconus 672
 Keratomalacia 157
 Kernicterus 236, 237
 Kernig sign 13
 Kerosene oil poisoning 612
 Kidney biopsy 751
 Kinky hair (Menkes) disease 162, 439
 Kiss the knee sign 256
 Klinefelter syndrome 631
 Klumpke paralysis 188
 Knock knee 710, 732
 Knock-knee deformity 641
 Kocher-Debre-Semelaigne (KDS) syndrome
 627
 Koebner response 606
 Kwashiorkor 133, 140
 Kyphosis 712

L

Lactation failure 119
 Lactobezoars 479

Lagophthalmos 670
 Laryngomalacia 686
 Laryngoscopy 322
 Latching 213
 Late infant mortality 84
 Lathyrism 617
 Laurence-Moon-Biedl syndrome 624, 639,
 640
 Lazy leukocyte syndrome 578
 Lead poisoning 616
 Learning disability 46
 Legionellosis 351
 Leishmaniasis' disease 351
Leishmania donovani 302, 304
 Leprosy 282, 600
 borderline 283
 lepromatous 283
 tuberculoid 283
 Leptospirosis 286
 Leukemia
 acute 555
 aleukemic 555
 chronic 555, 557
 congenital 557, 559
 Leukemoid reactions 557
 Leukocoria 673
 Leukocyte dysfunction 550
 Leukoderma 600
 Lid retraction 670
 Limb length discrepancy 715
 Limb-girdle muscular dystrophy 662
 Linear catchup growth 36
 Linear nevus syndrome 435
 Lissencephaly (agyria) 403
 Little disease 413
 Liver abscess 500
 Liver biopsy 751
 Long QT syndrome 390
 Longitudinal study 72
 Low birthweight infants 173, 206
 Lumbar puncture 749
 Lung abscess 334
 Lung biopsy 322
 Lung tap 322
 Lyell syndrome 597
 Lymph node biopsy 752
 Lymphangioma 707
 Lymphomas 559

M

Macular hemangioma 203
 Magnetic resonance imaging 735
 Malaria 296
 clinical features 298
 complications 298
 algid malaria 299
 black water fever 299

- cerebral malaria 299
 coagulation abnormalities 299
 hypoglycemia 299
 noncardiogenic pulmonary edema 299
 quartan malaria/nephropathy 300
 tropical splenomegaly 300
 diagnosis 300
 epidemiology 296
 host response 297
 life cycle of parasite 296
 pathogenesis 297
 treatment 300
- Malformations of kidney and urinary tract 505
- Malnutrition 65
 Malnutrition (tip of “iceberg”) 134
 Mantoux test 343
 Manual removal of foreign body from airway 753
 Maple syrup urine disease 648
 Marasmic kwashiorkor 134, 145
 Marble bone disease 715
 Marfan syndrome 590, 713
 Maternal and child health 82
 Maternal medication 243
 adverse effects on breastfed infant 244
 adverse effects on the fetus 243
 Maternal mortality rate 83
 Mayer-Rokitansky syndrome 505
 Mean corpuscular hemoglobin 757
 Mean deviation 72
 Measles (rubeola) 250
 clinical features 251
 complication 252
 diagnosis 252
 differential diagnosis 252
 etiopathogenesis 250
 prophylaxis 253
 treatment 253
 Measures of variation 72
 Meatal stenosis 506, 706
 Mechanical ventilation 755
 Mechanism of coagulation hemostasis 538
 Meckel’s diverticulum 700
 Meckel-Gruber syndrome 403
 Meconium aspiration syndrome 217
 Meconium ileus 699
 Meconium plug syndrome 699
 Median 72
 Medical informatics 73
 Mediterranean anemia 532
 Medulloblastoma 565
 Megaloblastic anemia 530
 Megalocornea 672
 Meningitis 416
 Meningocele 192, 402
 Meningococcal infections 286
 Meningoencephalitis 416
 Meningomyelocele 192, 402
- Menometrorrhagia 67
 Menstrual problems 67
 Mental retardation 53, 408
 Mercury poisoning 17
 Metabolic acidosis 177, 179
 Metabolic alkalosis 180
 Metabolic myopathies 662
 Metachromatic leukodystrophy 439
 Metered dose inhaler 337
 Methemoglobinemia 537
 Microcephaly 408
 Microcornea 672
 Microminerals 111
 Micronutrients 170
 Micropenis 633
 Microphthalmia 668
 Midarm circumference 32, 131
 Midday meal program 152
 Milia 202
 Mineral deficiencies 170
 arsenic 172
 calcium 172
 chromium 172
 cobalt 171
 copper 171
 fluorine 172
 iodine 172
 iron 170
 manganese 172
 molybdenum 172
 nickel 172
 potassium 173
 selenium 171
 silicon 172
 sodium 173
 vanadium 172
 zinc 170
 Minerals 111
 Missense mutation 643
 Mitral systolic murmur-systolic click syndrome 389
 Mitral valve prolapse syndrome 389
 Mixed acid-base disturbances 181
 Mixed connective tissue disease 588
 Mode 72
 Modern imaging techniques 733
 Molality 175
 Molluscum contagiosum 604
 Mongolian spots 6, 202
 Mongolism 410
 Moniliasis 226, 594
 Monkeypox 247
 Morphine and other opiates poisoning 616
 Morquio syndrome 653
 Motor neuron disorders 657
 Mucocutaneous lymph node syndrome 588
 Mucopolysaccharidoses 651, 650
 Mucoviscidosis 467
 Multiple sclerosis 440
- Mumps
 clinical features 254
 complications 255
 diagnosis 255
 differential diagnosis 254
 prophylaxis 255
 treatment 255
- Muscular dystrophies 659
 Mutation 642
 Myasthenia gravis 657
Mycobacterium leprae 282
 Myelodysplasia 402
 Myelomeningocele 402
 Myeloperoxidase deficiency 578
 Myocarditis 393
 Myopia 675
 Myotonic muscular dystrophy 661
 Myotubular myopathy 658
- N**
- Nabarrow’s thinners chart 131
 Nailbiting 56
 Nappie or napkin flash intertrigo 595
 Narcolepsy 68
 Nasal polyps 685
 Nasolacrimal duct blockade 204
 Natal teeth 203
 National immunization schedule 98
 National nutrition policy 153
 National nutrition programs 151
 Nebulizer 337, 338
 Necrotizing enterocolitis 700
 Neonatal and perinatal mortality in India 186
 Neonatal behavioral assessment scale 198
 Neonatal blood circulation 356
 Neonatal care 185
 Neonatal cholestasis syndrome 235, 496, 497
 Neonatal cold injury 241
 Neonatal conjunctivitis 225
 Neonatal hepatitis syndrome 235
 Neonatal hyperthermia 241
 Neonatal hypocalcemia 240
 Neonatal hypoglycemia 239
 Neonatal hypomagnesemia 240
 Neonatal hypothermia 210
 Neonatal jaundice 228, 231
 breastfeeding 229
 breastmilk 229
 pathologic 229
 physiologic 228
 Neonatal malaria 226
 Neonatal mortality 83
 Neonatal necrotizing enterocolitis 242
 Neonatal resuscitation 188
 Neonatal seizures 238
 Neonatal shock 218
 Neonatal tetanus 227, 240
 Nephritic syndrome 517

- Nephroblastoma 562
 Nephrogenic diabetes insipidus 512, 623
 Nettle rash 596
 Neural tube defects 402
 Neuroblastoma 563
 Neurocutaneous syndromes 434
 Neurocysticercosis 316, 427
 Neurodevelopment 198
 Neurofibromatosis 434
 Neurogenic bladder 506
 Neurologic evaluation 400
 Neurologic examination 12
 Neuromuscular transmission disorders 657
 Neuromyelitis optica 440
 Neurosis 52
 Neurotuberculosis 417
 Neutropenia 550
 Nevus flameus 600
 Nevus simplex 203
 Newer antituberculous drugs 349
 Newelof syndrome 577
 Niemann-Pick disease 650
 Night blindness 676
 Nipple discharge 68
 Nocturia 636
 Noma 294
 Noma neonatorum 226
 Nonaccidental injury 724
 Non-Hodgkin lymphoma 561
 Nonketotic hyperosmolar coma 637
 Nonnutritive suckling 125
 Nonorganic failure-to-thrive 725
 Noonan syndrome 631
 Normal laboratory values 785
 Nose disorders 683
 Nosebleeds 683
 Nosocomial infections 291
 common infections 293
 etiologic considerations 292
 investigations 293
 mode of transmission 292
 preventive and control measures 293
 Nuclear medicine 735
 Nursing bottle caries 690
 Nutritional anemia cycle 528
 Nutritional anemias 525
 Nutritional blindness prevention program 153
 Nutritional dwarfing 145
 Nutritional marasmus 133, 143
 Nutritional recovery syndrome 149
 Nyctopia 676
- O**
- Obesity 44, 65, 640
 Observation hip 718
 Obstructive uropathy 506, 704
 Occipital encephalocele 191
 Occult blood 760, 761
 Ocular trauma 679
 Omphalitis 223
 Oncologic emergencies 568
 Open care system 212
 Opening the airway 191
 Ophitoxemia 619
 Opportunistic infection 290
 Optic atrophy 678
 Optic nerve diseases 677
 Optic neuritis 677
 Oral polio vaccine program 101
 Oral rehydration therapy 448, 456
 Oral thrush 226
 Orbital cellulitis 669
 Orbital diseases 667
 Organic brain syndrome 52
 Organic phosphate poisoning 612
 Organogenesis 400
 Orthophoria 674
 Orthotopic liver transplantation 502
 Osmolarity 175
 Osmotic diarrhea 462
 Osteochondritis 715
 Osteogenesis imperfecta 712
 Osteomyelitis 716
 Osteopetrosis 715
 Osteosarcoma 566
 Otitic hydrocephalus 404
 Otitis externa 680
 Overfeeding 127
 Oxycephaly 428
 Oxytocin 623
 Oxyuriasis 313
- P**
- Panophthalmitis 157
 Papillary and iris abnormalities 673
 Papilledema 677
 Paracetamol toxicity 613
 Paralysis of accommodation 675
 Paraphimosis 506, 521, 706
 Paraplegia 440
 Parasitic infestations of gut 307
 Parathyroid and its disorders 629
 Parathyroid myopathy 662
 Parenteral nutrition 125
 Parietal abscess and fistula 701
 Paroxysmal atrial tachycardia 389
 Partial thoracic stomach 295
 Patent ductus arteriosus
 clinical features 365
 complications 365
 diagnosis 365
 pathophysiology 365
 treatment 366
 Pectus excavatum 164
 Pediatric AIDS 265
 clinical features 266
 diagnosis 266
 etiology 265
 pathogenesis 266
 prevention 268
 Pediatric drug dosage 775
 Pediatric education 23
 Pediatric fractures 719
 Pediatric sports medicine 718
 Pediatric sports medicine program 719
 Pediatrics
 changing scenario 15
 contemporary disease pattern 18
 delivery of child health care 20
 education 23
 mortality scenario 20
 rights of the child 17
 tropical pediatrics 16
 Pediatric syndromes 767
 Pediculosis 593
 Pellagra 160
 Pelviureteric junction (PUJ) stenosis 506
 Pemphigus 603
 Percentile 73
 Pericardial effusion 392
 Pericardial puncture 750
 Pericarditis 391
 Perinatal aids 223
 Perinatal asphyxia 213
 Perinatal mortality rate 84
 Perinatal/neonatal period 185
 Periodic syndrome 57
 Periorbital (preseptal) cellulitis 669
 Peripheral blood film 757
 Peroral jejunal biopsy 464
 Persistent diarrhea 459
 Persistent pulmonary hypertension of the newborn 218
 Pertussis 271
 Pes planovalgus 733
 Peter's anomaly 673
 pH 176
 Phakomatoses 434
 Phantom hernia 257
 Phenothiazine toxicity 614
 Phenylketonuria 47
 Phimosis 204, 506, 521, 706
 Phlyctenular keratoconjunctivitis 672
 Phlyctenules 672
 Phocomelia 709
 Phototherapy 230, 752
 Physical examination 6
 Physiologic anemia of prematurity 528
 Physiologic mastitis 203
 Physiology of lactation
 oxytocin milk ejection reflex 115
 prolactin milk-secreting reflex 115
 rooting reflex 116
 suckling reflex 116
 swallowing reflex 116
 Phytobezoars 479
 Pica 54

- Pierre Robin syndrome 190
 Pilocarpine iontophoresis 322
 Pilonoidal sinus and abscess 701
 Pingueculum 672
 Pitting edema 12
 Pituitary and its disorders 624
 Pituitary dwarfism 628
 Plagiocephaly 428
Plasmodium 298
 Plastic pleurisy 331
 Platelet count 540, 758
 Pleural effusion 331, 332
 Plucked bird disease 729
 Plumbism 616
 Pneumonias 327
 staphylococcal 327
 Poliomyelitis 255
 clinical features 256
 complications 258
 diagnosis 258
 etiopathogenesis 256
 prophylaxis 259
 treatment 258
 Polyarteritis nodosa 589
 Polyarteritis nodosa periarteritis 587
 Polyarthritides 378
 Polycystic disease of kidneys 505
 Polycythemia 552
 Polydactyly 710
 Polydypsia 636
 Polygraphic monitoring 322
 Polymorphisms 643
 Polyphagia 636
 Polyuria 636
 Pontiac fever 351
 Pontine glioma 565
 Porencephaly 404
 Pork tapeworm 315
 Portal hypertension 494
 Portwine stain or mark 600
 Positive pressure ventilation 193
 Posterior urethral valve 506, 704
 Postinfectious polyneuritis 406
 Postnatal growth curves 28
 Postneonatal mortality 84
 Potassium 176
 Potassium-related periodic paralysis 662
 Potentially dangerous sting 621
 Prader-Willi syndrome 640
 Prazosin 621
 Precocious puberty 631
 Pre-excitation syndrome 390
 Prekwasiorokor 145
 Premature senility 729
 Premenstrual syndrome 67
 Prenatal diagnosis 653
 Preterm infant 204
 Preventive pediatrics 79
 Priapism 705
 Prickly heat 595
 Primary bladder stone 521
 disease 705
 Primitive neonatal reflexes 199
 Chvostek sign 201
 crossed extension 201
 glabellar reflex/tap 201
 grasp 201
 Landau 202
 Moro 199
 parachute 201
 plantar (Babinski) 201
 rooting and suckling 201
 startle response 201
 tonic neck 201
 traction 201
 Probability 73
 Progeria 729
 Prolactin 624
 Promiscuous sex 63
 Proptosis 668
 Protein 110
 Protein-energy malnutrition 133
 classification 139
 complications 146
 evolution
 adaptation hypothesis 134
 aflatoxin contamination hypothesis 134
 dietary hypothesis 134
 Golden's hypothesis of free radicals 134
 Jellife's hypothesis of interactions 134
 long-term sequelae 150
 management
 domiciliary (home) management 146
 hospital management 147
 management in nutrition 146
 rehabilitation 146
 PEM and
 disturbances of metabolism 135
 endocrinal status 137
 family planning 137
 infection 136
 cardiac function 138
 diarrhea 138
 drug disposition 139
 renal function 139
 prevention 150
 community level 151
 family level 151
 national level 151
 world level 151
 prognosis 150
 Protein-losing enteropathy 469
 Proteinuria 507
 Prothrombin time 540
 Protuberant abdomen 732
 Pruritus ani 313
 Pseudodeficiency rickets 164
 Pseudoachondroplasia 715
 Pseudohermaphroditism 63
 Pseudohypertrophic muscular dystrophy 659, 660, 661
 Pseudohypoparathyroidism 630
 Pseudomembranous colitis 455
 Pseudotumor cerebri 149, 404
 Psoas abscess 342
 Psoriasis 606
 Psychiatric disorders 52
 Psychogenic vision problems 676
 Psychosis 52
 Pterygium 672
 Ptosis 669
 Puberty 37
 Puberty goiter 65
 Puberty spurt 61
 Pulmonary function tests 322
 Pulse polio 101
 Pulseless disease 390
 Purpura fulminans 550
 Pyelonephritis 509
 Pyoderma 226, 596
 Pyogenic liver abscess 500
 Pyridoxine (vitamin B₆) dependency anemia 529
 Pyruvate kinase deficiency 536
- Q**
-
- Qartan malaria/nephropathy 300
 QUAC-stick method 131
 Quetlet index 132
- R**
-
- Rabies 264
 Rachitic rosary 165
 Radial club hand 709
 Radionuclide scintigraphy 735
 Range 72
 Reactive airway disease 334
 Rectal examination 11
 Rectal infusion 748
 Recurrent abdominal pain 477
 Recurrent aphthous stomatitis 473
 Recurrent convulsions 431
 Recurrent neonatal apnea 219
 Recurrent respiratory infection 350
 Red cell count 757
 Refeeding edema 148
 Refractive errors 675
 Refractory rickets 166
 Regurgitation 126
 Rehabilitation 90
 Renal agenesis 505
 Renal or uremic rickets or dwarfism 522
 Renal osteodystrophy 522
 Renal rickets 164
 Renal stone 521, 704
 Renal system 504
 Renal tubular acidosis 511
 Reproductive and child health (RCH) program 94

- Respiratory acidosis 177, 180
 Respiratory alkalosis 177, 181
 Respiratory catarrh 323
 Respiratory distress of polio 257
 Respiratory distress syndrome 215
 Respiratory syncytial virus infection 268, 324
 Respiratory system examination 8
 Reticular pigmentation of skin 727
 Reticulocyte count 758
 Retinal detachment 677
 Retinitis pigmentosa 676
 Retinoblastoma 567, 676
 Retinopathy of prematurity 206 676
 Retracted nipples 118
 Retrobulbar neuritis 677
 Retrolental fibroplasias 676
 Rett syndrome 48, 439
 Reye syndrome 434, 484
 Rh isoimmunization 236
 Rhabdomyosarcoma 567
 Rhesus hemolytic disease 236
 Rheumatic (Sydenham's) chorea 378
 Rheumatic fever 376, 584
 Rheumatic heart disease 382
 aortic regurgitation 385
 mitral regurgitation 383
 mitral stenosis 383
 rheumatic aortic valve disease 385
 rheumatic tricuspid valve disease 386
 Rheumatoid arthritis 718
 Rhinopharyngitis 323
 Rhythmic dilatation and constriction of pupil 673
 Rickets 150
Rickettsia prozawekii 275
 Rights of the child 17
 Ringworm infections 594
 Ritter disease 597
 Rooting reflex 212
 Rotahaler 337, 338
 Roth's spot 387
 Routine diabetes 637
- S**
- Salicylism 614
 Saline washed platelets 554
 Salmon patches 203
Salmonella 276
 Salter spring machine 29
 Sarcoidosis 731
 Scabies 593
 Scalded skin syndrome 597
 Scalp vein infusion 745, 746
 Scaphocephaly 428
 Scapuloperoneal or scapulohumeral muscular dystrophy 661
 Schilder disease 439
 Schizencephaly 403
 School health service 81
 School phobia 57
 Sclerema 241
 Sclerocornea 672
 Scleroderma 588
 Scoliosis 712
 Scorbutic rosary 162
 Scorpion sting 621
 Scrofuloderma 342
 Seborrhea 595
 Seborrheic dermatitis 595
 Secretory diarrhea 462
 Self-gratification 63
 Self-inflating bag 194
 Septic umbilicus 223
 Septicemia 223
 Severe acute respiratory syndrome 269, 326
 Sex chromatin 645
 Sex-determination shops 91
 Sexual abuse 725
 Sexually transmitted diseases 67
 Shakir tape 131
 Shigellosis 454
 Shock 736
 Short stature 42, 624, 641
 Sick sinus syndrome 390
 Sick cell anemia 535
 Sideroblastic anemia 529
 Significant value 73
 Simian (single palmar) crease 412
 Sinusitis 684
 Skin tests 321
 Skin tuberculosis 604
 Skin-eye-mouth disease 222
 Skin-fold thickness 34
 Sleep disorders 68
 Sleep walking 55
 Slipped capital femoral epiphysis 711
 Slow virus infection 264
 Smallpox (variola) 247
 Snake bite 619
 Snoring 350
 Social pediatrics 79
 Sodium 175
 Soft tissue sarcomas 567
 Somnambulism 55
 Sore nipple 118
 Space device inhaler 337
 Spasmus nutans 435
 Spastic Society of India 415
 Special nutrition program 151
 Spider nevus 601
 Spina bifida occulta 402
 Spinal muscular atrophies 658
 Spinhaler 337
 Squint 674
 Stages of newborn care 208
 Standard deviation 72
 Staphylococcal scalded skin syndrome 597, 598
 Statistical averages 72
 Status asthmaticus 338
 Status epilepticus 432
 Sternocleidomastoid tumor 708
 Sternomastoid tumor 708
 Steroid-induced myopathy 662
 Stevens-Johnson syndrome 602
 Stool examination 760
 fat globules 762
 formalin-ether sedimentation technique 761
 microscopy 760
 occult blood 761
 pH 762
 reducing substances 762
 zinc sulfate 761
 Stork bites 203
 Strabismus 674
 Strabismus syndromes 674
 Street children 88
 Stress (secondary) ulcer disease 474
 Stridor 220, 350, 686
 Stroke 405
 Strongyloidiasis 314
 Stunting 145
 Sturge-Weber disease 434
 Stuttering 56
 Subacute sclerosing panencephalitis 438
 Subconjunctival hemorrhage 203, 671
 Subcutaneous emphysema 328
 Subcutaneous infusion 748
 Subcutaneous injection 744
 Subcutaneous nodules 379
 Subdural effusion 426
 Subdural hematoma 426
 Subdural puncture or tap 749
 Substance abuse 57, 66
 Suckling 126
 Suckling callosities 203
 Suckling reflex 212
 Sudamina 595
 Sudden infant death syndrome 728
 Suicide 66
 Suprapubic bladder aspiration 751
 Swallowing difficulties 126
 Swallowing reflex 212
 Swimmer's ear 680
 Syllabus (MCI) 792
 final MBBS part II 793
 undergraduates 792
 Symblepharon 672
 Syncope 736
 Syndactyly 710
 Syndrome of generalized lipodystrophy 624
 Syphilis 284
 syphilitic stigmata 285
 Syringomyelia 403
 System review 5

Systemic hypertension 394
Systemic lupus erythematosus 586

T

Tactile stimulation 193
Takayasu arteritis 390, 590
Tanner's sexual maturity rating 60, 62
Tapeworms 315
T-cell defects 576
Teenage pregnancy 66
Teeth grinding 56
Telangiectatic angioma 601
Telemedicine 74
Television and the child 95
Tenia solium 315
Teratomas 568
Testing of cranial nerves 13
Tetanus 280
Tetanus neonatorum 227
Tethered spinal cord 403
Tetralogy of Fallot 366
Thalassemia 532
The Child Labor (Protection and Regulation) Act, 1986 88
The genes 643
The handicapped child 89
Thoracentesis 750
Thoracocentesis 322
Thoracoscopy 322
Throat disorders 685
Thrombin time 540
Thrombocytopenic purpura 546
Thrush 474
Thumb sucking 56
Thymoma 568
Thyroglossal cyst 708
Thyroid and its disorders 625
Thyroid myopathy 662
Thyroid-stimulating hormone 624
Thyromegaly 629
Tics 56
Tietze syndrome 69
Tight external urethral meatus 706
Tongue-tie 732
Tonsillitis 685
Total anomalous pulmonary venous return 372
Total body water 174
Total leukocyte count 757
Tourette syndrome 57
Toxic epidermal necrolysis 597
Toxic erythema 202
Toxic shock syndrome 294
Toxin elimination 610
Trace elements 111
Tracheoesophageal fistula 695
Tracheostomy 687
Tracheoesophageal fistula 242
Transient hypoparathyroidism 630

Transient synovitis of the hip 718
Transient tachypnea of the newborn 218
Transillumination 322
Transitional stools 202
Transport of sick neonates 242
Transposition of great arteries 371
Triceps skin fold thickness 131
Trichobezoars 54, 479
Trichotillomania 54
Trichuriasis 314
Tricuspid atresia 369
Tricuspid regurgitation 386
Trigger thumb 710
Trilateral retinoblastoma 568
Tripod sign 256
Tropical eosinophilia 306
Tropical pediatrics 16
Tropical splenomegaly 301, 307
Tuberculoma 420
Tuberculosis 286, 339, 341
 abdominal 342
 chronic pulmonary 343
 CNS 341, 417
 miliary 341
 renal 342
 skeletal 342
Tuberculosis of bones and joints 717
Tuberculous encephalopathy 420
Tuberculous meningitis 417, 418
Tuberculous ulcers 343
Tuberous sclerosis 434
Tumors 670
Turbuhaler 337
Turner syndrome 631
Types of fever
Types of inheritance 643
Types of studies 72
Typhoid fever 276
Tyrosinemia 649

U

Ultrasonography 733
Umbilical hernia 204, 480, 701, 732
Umbilical polyp 701
Umbilical vein catheterization 746
Under-5 mortality rate 84
Underfeeding 127
Under-fives clinics 80
Undescended testis 68, 631, 707
Upper respiratory tract infection 323
Urinary tract infection 509
Urine examination 758
 chemical examination 759
 albumin 759
 bile pigments 760
 bile salts 760
 dipstick test 759
 ketones 759
 occult blood 760

 phenylpyruvic acid 760
 porphyrins 760
 sugar 759
 physical examination 758
 urine microscopy 760
Urticaria 596

V

Vaccination 97
 BCG 98
 cholera 103
 combination 106
 DPT 102
 H. influenzae 105
 hepatitis A 106
 hepatitis B 105
 influenza 107
 Japanese encephalitis 108
 measles 103
 meningococcal 107
 MMR 104
 mump 104
 pneumococcal 107
 polio 100
 rabies 108
 rubella 104
 typhoid 103
 varicella virus (chickenpox) 106
Vaccine vial monitoring 98
Vaginal bleeding 203
Varicella bullosa 248
Vasculitis syndromes 588
Vasopressin 623
Vasopressin sensitive diabetes insipidus 623
Venesection (cutdown or cutopen) 746
Venipuncture 744
Venous thromboembolism 551
Venous thrombosis 405
Ventricular septal defect
 classification 361
 clinical features 362
 complications 363
 diagnosis 362
 hemodynamics 361
 treatment 363
Ventricular tap 750
Viral hepatitis 264, 487
Viral pharyngitis 685
Visual disorders 675
Vitamin D-deficiency rickets 164
Vitamin deficiencies 155
 folic acid 161
 nicotinic acid 160
 pyridoxine 160
 riboflavin 159
 thiamine 158
 vitamin A 155
 vitamin B₁₂ 161

vitamin C 161
vitamin D 163
vitamin E 167
vitamin K 168
Vitamin K deficiency bleeding 542
Vitamins 111
Vitellointestinal fistula 701
Vitiligo 600
Vomiting 126, 202, 473
Von Hippel-Lindau disease 434
Von Willebrand disease 546

W

Waddling gait 659
Warm chain 211

Warts 604
Water 109
Waterhouse-Friderichen syndrome 630, 416
Wax (cerumen) 680
Weaning 120
Websites on pediatrics and allied fields 793
Wegener's granulomatosis 590
Werlhof disease 546
Wheezy chest 350
Whipworm 314
White line of Frankel 162
WHO ATT regimens 346
WHO growth chart 29
Whole bowel irrigation 610
Whooping cough 271

Wilms' tumor 562
Wilson disease 440, 501
Wiskott-aldrich syndrome 57, 548
Wolf-Parkinson-White syndrome 390
World breastfeeding week themes 788
World health day (April 7) themes 788
World wide web 76
Wormian bones 32
Wright stain 758
Wuchereria bancrofti 305

X

Xerophthalmia 156